

2018

MASTER CATALOG

**DRAG, MUSCLE CAR,
STREET ROD, HIGH
PERFORMANCE**

**SUSPENSION
BRAKES
COOLING**





WHO WE ARE AFCO is an engineering based manufacturing company staffed by experienced professionals who are passionate about the racing industry. AFCO started with a simple need for a better suspension component. Now, after 30 years, we have grown into a full service manufacturing and distribution company that builds industry leading suspension, cooling and brake components. Our products are distributed by the finest automotive aftermarket chassis builders, warehouses, and retailers throughout North America, Europe, Australia and New Zealand. Three decades of working closely with racers and tuners has yielded a team focused on delivering superior performance, quality, and value in every product we make.



 **PREMIER DESIGN & ENGINEERING**

Our great products start with the best design and engineering people. Our engineering team is one of the most experienced in the industry. AFCO products are known for reliability, performance, value and innovation. Before we ever release the first iteration of a new product, we use a combination of: vehicle data collection tools, extensive CAD modeling, finite element analysis testing, laboratory testing and extensive field trials to make sure you are getting the best product for your money. We spend countless hours on the road testing and refining our products at the tracks with our customers so you can be sure our products will work as advertised every time!

 **MANUFACTURING EXCELLENCE**

Our experienced, dedicated manufacturing personnel use automated production machines such as CNC benders, CNC lathes and mills, and laser cutting equipment to give us the ability to produce the highest quality, most consistent products in our industry.

The AFCO advantage is available in thousands of products for a wide range of applications.



UNRIVALED CUSTOMER SERVICE & TRAINING

We understand the needs of our customers and we respond with outstanding technical support and customer service. Shock schools, chassis seminars, product training, fast and friendly service are all part of what you get when you purchase AFCO products.



WINNING PRODUCTS

The common thread that ties all AFCO products together is performance. AFCO products are built to perform because we love it when our customers win! Our unrelenting passion to be the best is the reason professional racers have relied on AFCO products for over 30 years!



CUSTOMIZATION YOU CAN COUNT ON

We strive to meet our customer's specific needs. We can often build to your custom specifications. We look forward to fulfilling your custom orders.

DRAG, MUSCLE, STREET ROD & HIGH PERFORMANCE INDEX

SHOCKS

8-41

DRAG RACING SHOCKS & STRUTS

DRAG STRUTS	8-15
DOMINATOR 4-WAY SHOCKS	16-17
BIG GUN SHOCKS (GAS/TWIN TUBE)	18-21
ELIMINATOR TWIN TUBE SHOCKS	22-25, 28
REACTOR MONOTUBE SHOCKS	26-27
COIL-OVER CONVERSION CHART	28
PRO STREET SHOCKS	29
STREET FIGHTER SHOCKS	30-31

HIGH PERFORMANCE SHOCKS

'10-'11 CAMARO SUSPENSION PACKAGE	32
-----------------------------------	----

MUSCLE CAR SHOCKS

PRO TOURING SHOCKS	33
BILLET ALUMINUM SHOCKS	34-37

SHOCK REBUILD PARTS AND TOOLS

SHOCK ACCESSORIES	38-41
-------------------	-------

SUSPENSION

42-51

COIL-OVER SPRINGS	42-45
CHROME TAPERED SPRINGS	45
LOW FRICTION BALL JOINTS	46
EXTENDED LENGTH LOW FRICTION BALL JOINTS	46
STANDARD BALL JOINTS	46
BALL JOINT SLEEVES	47
BUSHINGS	48-49
LEAF SPRINGS	50
LEAF SPRING ACCESSORIES	51

STEERING

52-55

TIE ROD ENDS	52
ROD ENDS	53
PINTO SPINDLES	54
U-JOINTS AND COUPLERS	54

ACCESSORIES

55

ENGINE MOUNTS	55
BATTERY BOXES	55
TRAILING ARM BRACKETS	55
BRAKE SHUT-OFF VALVE	55
HOOD PIN KITS AND COMPONENTS	55
FUEL/CARBURATION ACCESSORIES	55
AIR CLEANER HOUSING	55
SWITCHES/SENDING UNITS/WARNING LIGHTS	55

BRAKES

56-67

CALIPERS

F33 FORGED ALUMINUM CALIPERS	57
F11 FORGED ALUMINUM CALIPERS	57
METRIC CALIPERS	58
METRIC ALUMINUM CALIPERS	58
LIGHTWEIGHT CAST IRON CALIPERS	58

MASTER CYLINDERS

INTEGRAL RESERVOIR MASTER CYLINDER	60
INTEGRAL PARTS & REBUILD KITS	60
REMOTE RESERVOIR MASTER CYLINDER KIT	61
REMOTE PARTS & REBUILD KITS	61

BRAKE ROTORS

GM METRIC STYLE ROTOR	62
FORD STYLE ROTOR	62
DISC BRAKE BOLT-ON KIT	63

BRAKE ACCESSORIES

BRAKE PADS	59
CALIPER PRESSURE GAUGE & ADAPTERS	63
CALIPERS BRACKETS	63
PEDALS	64
HIGH PERFORMANCE BRAKE FLUID	65
BRAKE SYSTEM FITTINGS	66-67
BRAKE LINES	67
BRAKE FITTING CLIP	67
BRAKE SHUT-OFF VALVE	67

COOLING

68-119

RADIATORS

DRAGSTER/ROADSTER RADIATORS	70
DRAG RACING POWER-ADDER RADIATORS	70
SCIROCCO-STYLE DRAG RACING RADIATORS	71
PERFORMANCE-FIT RADIATORS	72
LIGHTWEIGHT SINGLE ROW CORE RADIATORS	73
UNIVERSAL SINGLE PASS RADIATORS	74
UNIVERSAL DOUBLE PASS RADIATORS	75
'79-'04 MUSTANG RADIATORS	76-77
HIGH PERFORMANCE RADIATORS	78-79
MUSCLE CAR RADIATORS	86-104
CUSTOM RADIATORS	105
STREET ROD RADIATORS	106-113

HEAT EXCHANGERS

CUSTOM HEAT EXCHANGERS	81
FORD HEAT EXCHANGERS	82-83
CHEVY HEAT EXCHANGERS	84-85

COOLING ACCESSORIES

FAN SHROUDS	73
COOLANT TANKS	116
TRANSMISSION/ENGINE OIL COOLERS	114
HOSES	116
RADIATOR CAPS & COMPONENTS	117
COOLING FANS & COMPONENTS	115, 118
RADIATOR FITTINGS	119
COOLANT AND COOLANT ADDITIVE	119

APPAREL

120-122

INDUSTRY LEADING SUPPORT

ENGINEERING EXCELLENCE

AFCO Performace Group is dedicated to engineering high quality racing components that allows our dealers to develop championship winning suspension packages.



FASTSHOCKS

"FastShocks has worked closely with AFCO since we first opened our doors. The quality of AFCO components gives us a perfect platform to custom build shocks that have helped our customers refine their suspensions from coast to coast. When customers like Jimmy Hidalgo Jr, Justin Lamb, Peter Biondo, and Gary Stinnett look for suspension control for their exact application - we choose AFCO." - Randy Mans



TINNIN DRAG RACE SUSPENSION

"At Tinnin Suspension, we rely on AFCO Racing Products to provide quality suspension components and product flexibility that allows us to provide our customers with a winning suspension package that is second to none." - Matt Tinnin



MENSCHER MOTORSPORTS

“Menschers Motorsports appreciates the engineering and product support from AFCO that allows us to design and develop the most innovative suspension packages in the industry today. The on-track success of our customers fuels our passion for winning. With AFCO as a partner, we will continue our drive to win.” - Mark Menschers



DEWAYNE MILLS



JACKY MCCARTY



SHAWN PEVLOR



MO HALL



ZIFF HUDSON



LYLE BARNETT



SHAWN AYERS



JOSH KLUGGER



GEORGE REHAYEM



NEW PRODUCTS

TERMINATOR SERIES SPINDLE MOUNT STRUTS

AFCO is proud to bring to market the most advanced and most adjustable spindle mount strut available today. You will not find a more user-friendly adjustable strut at any cost. Each adjustment is metered with a detent for precise adjustments. These struts are available in 3 lengths to fit virtually every ride height. Double adjustable struts allow for nearly infinite chassis tuning combinations, but more importantly, the broad range of adjustment offered will allow tuners to find the sweet spot quickly and efficiently. For more details on AFCO's Terminator Series spindle mount struts, **please see pages 8-9.**

DOUBLE ADJUSTABLE!

Widest range of adjustment on the market! Fully independent compression and rebound adjustments to dial your chassis in "click" by "click".



COMPRESSION ADJUSTMENT.



REBOUND ADJUSTMENT.



TERMINATOR SS SERIES SPINDLE MOUNT STRUTS

Are you ready to make a move to lighten your front suspension with Spindle Mount Struts? Already made that move but looking for improved performance? Now is the time to switch to the unmatched control of AFCO Terminator SS Series Struts. These struts are available in 4" and 6" stroke to fit virtually every ride height. The struts allow adjust for almost infinite chassis tuning combinations, but more importantly, this broad range of adjustment will allow tuners to find the sweet spot quickly and efficiently. For more details on AFCO's Terminator SS Series Spindle Mount Struts, **please see pages 10-11.**

DOUBLE ADJUSTABLE!

Widest range of adjustment on the market! Fully independent compression and rebound adjustments to dial your chassis in "click" by "click".



COMPRESSION ADJUSTMENT.



REBOUND ADJUSTMENT.



DOMINATOR SERIES 4-WAY ADJUSTABLE SHOCKS

The engineers at AFCO designed the new 4-way shock program with performance and function in mind. This shock series features the same traction enhancing technology found in all AFCO Shocks, but is fully high and low speed adjustable on both compression and rebound damping. Unlike other adjustable shocks, hysteresis is minimized and remains low regardless of the adjustment position or range. This allows for a wide adjustment range without sacrificing performance. This series is ideal for everyone from the over-achieving sportsman to the professional racer. For more details on AFCO's Dominator Series 4-way Shocks, **please see pages 16-17.**



STREET FIGHTER SERIES SHOCKS



AFCO's latest monotube technology is now available in a single adjustable stock mount design for many street and strip applications. The new stock mount shock is designed to fit in the OEM locations and offers great control, consistency and tunability. A wide range of rebound adjustability lets you tune your chassis from controlling the initial hit at the rear tires, to controlling front weight transfer to keep those tires hooked. Now is the right time to invest in higher shock technology. For more details on AFCO's Street Fighter Series Shocks, **please see pages 30-31.**



Shane Stack - 2017 Limited Drag Radial Class Champion

TERMINATOR

**Best Pro and Sportsman
strut on the market!**

SPINDLE MOUNT ADJUSTABLE STRUTS

NEW!

AFCO is proud to bring to market the most advanced and most adjustable spindle mount strut available today. Sporting a large 46mm monotube piston, the range of adjustment is un-matched to enhance tuning and performance. You will not find a more user friendly adjustable strut at any cost. Each adjustment is metered with a detent for precise adjustments. These struts are available in 3 lengths to fit virtually every ride height. A perfect choice for "No Prep" style of racing, the "extra travel" models promote additional weight transfer to hook on low traction surfaces. For more conventional applications, the new AFCO Terminator Series Struts are offered in common lengths to retro fit to existing chassis in the field or new builds that need to fit an existing jig.

Double adjustable struts allow for nearly infinite chassis tuning combinations, but more importantly, the broad range of adjustment offered will allow tuners to find the sweet spot quickly and efficiently.

- 3 lengths are available to fit most tube chassis applications.
- 100% Dyno tested for accuracy and quality.
- Double Adjustable 46mm monotube design provides broad range of adjustment.
- Fully independent compression and rebound adjustments for ultimate tuning and performance.
- AFCO Exclusive aluminum steering arm gives better tire clearance. "Competitor style" steel steering arm allows you to upgrade to an AFCO strut without having to shorten tie rod assembly.
- Pro style coil-over spring adjuster nut has positive clicks with each turn, locks in place with an allen wrench and has pronounced finger grips to aid setting ride height. Spanner wrench may also be used to set ride height.
- 2 or 4 piston caliper brackets available.
- '67-'69 Camaro pin design for common wheel/brake kit fitment.
- Best front end control on the market!



**COIL-OVER KIT
INCLUDED**

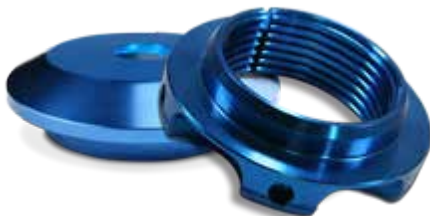

DOUBLE ADJUSTABLE!

Widest range of adjustment on the market! Fully independent compression and rebound adjustments to dial your chassis in "click" by "click".



COMPRESSION ADJUSTMENT.



REBOUND ADJUSTMENT.

TERMINATOR CHASSIS STRUT

(SOLD AS A PAIR)

DESCRIPTION	DIMENSIONS	PART #
2.5" STROKE ALUMINUM STEERING ARM*	8.2" COMP. X 11.63" EXT.	30625A
2.5" STROKE STEEL STEERING ARM**	8.2" COMP. X 11.63" EXT.	30625S
3.5" STROKE ALUMINUM STEERING ARM*	9.2" COMP. X 13.63" EXT.	30635A
3.5" STROKE STEEL STEERING ARM**	9.2" COMP. X 13.63" EXT.	30635S
4.5" STROKE ALUMINUM STEERING ARM*	10.2" COMP. X 15.63" EXT.	30645A
4.5" STROKE STEEL STEERING ARM**	10.2" COMP. X 15.63" EXT.	30645S

NOTE: *ALUMINUM STEERING ARMS ARE DESIGNED FOR NEW CHASSIS BUILDS.
**STEEL ARMS ARE DESIGNATED FOR EXISTING RACE CARS.

BRAKE BRACKET KIT

Brackets are designed for standard hub-type setup. These brackets will not work with brake kits designed for spindle-mount wheels.

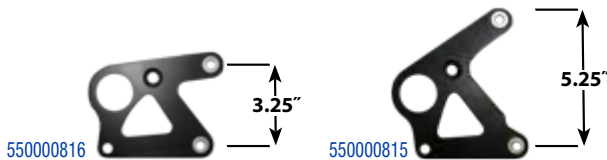

DESCRIPTION	PART #
2 PISTON CALIPER (3.25")	550000816
4 PISTON CALIPER (5.25")	550000815

*BRACKET KITS COME WITH 2 BRACKETS AND MOUNTING HARDWARE.

BEARING KIT



DESCRIPTION	PART #
TIMKEN COMPLETE BEARING KIT ('67-'69 CAMARO)	550001007

CANISTER MOUNTS

Use to mount strut canisters to chassis.



DESCRIPTION	PART #
1-1/4" CANISTER MOUNT	50330
1-3/8"	50329
1-1/2"	50331
1-3/4"	50332
QUICK PINS (4 PACK)	50334



TERMINATOR SS

Perfect control for Super Stock style racing!

SPINDLE MOUNT ADJUSTABLE STRUTS

NEW!

AFCO is proud to bring to market the most advanced and most adjustable spindle mount strut available today. Sporting a large 35mm twin tube piston, the range of adjustment is un-matched to enhance tuning and performance. You will not find a more user friendly adjustable strut at any cost. Each adjustment is metered with a detent for precise adjustments. These struts are available in 2 lengths to fit virtually every ride height. A perfect choice for "No Prep" style of racing, the "extra travel" models promote additional weight transfer to hook on low traction surfaces. For more conventional applications, the new AFCO Terminator SS Series Struts are offered in common lengths to retro fit to existing chassis in the field or new builds that need to fit an existing jig.

Double adjustable struts allow for nearly infinite chassis tuning combinations, but more importantly, the broad range of adjustment offered will allow tuners to find the sweet spot quickly and efficiently.

- 2 lengths are available to fit most super stock style applications.
- 100% Dyno tested for accuracy and quality.
- Double Adjustable 35mm twin tube design provides broad range of adjustment.
- Fully independent compression and rebound adjustments for ultimate tuning and performance.
- AFCO Exclusive aluminum steering arm gives better tire clearance. "Competitor style" steel steering arm allows you to upgrade to an AFCO strut without having to shorten tie rod assembly.
- Pro style coil-over spring adjuster nut has positive clicks with each turn, locks in place with an allen wrench and has pronounced finger grips to aid setting ride height. Spanner wrench may also be used to set ride height.
- 2 or 4 piston caliper brackets available.
- '67-'69 Camaro pin design for common wheel/brake kit fitment.
- Best front end control on the market!



COIL-OVER KIT INCLUDED



DOUBLE ADJUSTABLE!

Widest range of adjustment on the market! Fully independent compression and rebound adjustments to dial your chassis in "click" by "click".



COMPRESSION ADJUSTMENT.



REBOUND ADJUSTMENT.



TERMINATOR SS CHASSIS STRUT (SOLD AS A PAIR)

DESCRIPTION	DIMENSIONS	PART #
4" STROKE ALUMINUM STEERING ARM, CASTER CAMBER MOUNT* (PAIR)	13.77" COMP. X 18.30" EXT.	30740AC
4" STROKE ALUMINUM STEERING ARM, BUSHING MOUNT* (PAIR)	13.77" COMP. X 18.30" EXT.	30740AB
4" STROKE STEEL STEERING ARM, CASTER CAMBER MOUNT** (PAIR)	13.77" COMP. X 18.30" EXT.	30740SC
4" STROKE STEEL STEERING ARM, BUSHING MOUNT** (PAIR)	13.77" COMP. X 18.30" EXT.	30740SB
6" STROKE ALUMINUM STEERING ARM, CASTER CAMBER MOUNT* (PAIR)	15.77" COMP X 22.30" EXT.	30760AC
6" STROKE ALUMINUM STEERING ARM, BUSHING MOUNT* (PAIR)	15.77" COMP X 22.30" EXT.	30760AB
6" STROKE STEEL STEERING ARM, CASTER CAMBER MOUNT** (PAIR)	15.77" COMP X 22.30" EXT.	30760SC
6" STROKE STEEL STEERING ARM, BUSHING MOUNT** (PAIR)	15.77" COMP X 22.30" EXT.	30760SB

NOTE: *ALUMINUM STEERING ARMS ARE DESIGNED FOR NEW CHASSIS BUILDS.
**STEEL ARMS ARE DESIGNATED FOR EXISTING RACE CARS.

CASTER/CAMBER PLATES

DESCRIPTION	PART#
CASTER/CAMBER PLATES, MUSTANG ('79-'89)	40022
CASTER/CAMBER PLATES, MUSTANG ('90-'93)	40023
CASTER/CAMBER PLATES, MUSTANG ('94-'04)	40024



BRAKE BRACKET KIT

Brackets are designed for standard hub-type setup. These brackets will not work with brake kits designed for spindle-mount wheels.

DESCRIPTION	PART #
2 PISTON CALIPER (3.25")	550000816
4 PISTON CALIPER (5.25")	550000815

*BRACKET KITS COME WITH 2 BRACKETS AND MOUNTING HARDWARE.

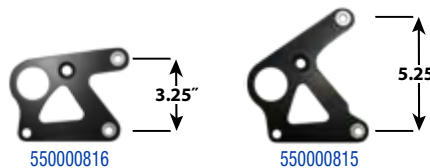

BEARING KIT

DESCRIPTION	PART #
TIMKEN COMPLETE BEARING KIT ('67-'69 CAMARO)	550001007



DRAG STRUTS

**Best Wheelie Control
Valving In The Market!**

FORD MUSTANG ADJUSTABLE STRUTS

After the tremendous success of our '79-'04 Mustang Strut, AFCO has expanded this technology for even more offerings. In most applications and classes, controlling weight transfer is key to making successful passes. Racers and chassis builders across the market requested a strut that can be used to control front end travel hydraulically instead of mechanically with a chain or cable. The engineering team at AFCO nailed it. The AFCO Big Gun Strut offers tuners the ability to "lock down" the front suspension to create a smooth weight transfer event.

- Double adjustable design-dial in your chassis, click-by-click.
- Best front-end control on the market.
- Fully independent compression and rebound adjustments.
- 35mm piston diameter; up to 37% larger than the competition for superior fluid control and consistency.
- Indexable compression adjuster for increased clearance options at the base of the strut.
- Rebuildable and revalvable as needed; widest possible range in the industry.
- CAD designed and FEA optimized.
- Cars running at 10.99 E.T. and slower, call for your specific valving.



30030
'79-'04 MUSTANG



30033
'05-'14 MUSTANG



DESCRIPTION	PART #
'79-'04 MUSTANG STRUT*	30030
'05-'14 MUSTANG STRUT*	30033

* AFTERMARKET CASTER/CAMBER PLATES REQUIRED FOR INSTALLATION (SEE PAGE 13). DRAG STRUTS DO NOT HAVE PROVISIONS FOR SWAY BAR MOUNTS.



**LOCKING COIL-OVER
KIT INCLUDED**

“STREET FIGHTER” SERIES - NON-ADJUSTABLE STRUTS

- The “Street Fighter” Series - Great for street or strip.
- Race-inspired valving for maximum weight transfer and bounce control. (BNC) (90-10, Non-Adjustable)
- Can be used as a replacement strut if retaining OEM springs.
- Can be used as a coil-over strut with optional coil-over kit, caster/camber plates, and coil-over springs (sold separately).
- Coil-over design for ride height adjustments and precise chassis adjustment.
- Allows for “Lowered Stance” ride height appearance. (Caster/Camber Plates recommended).



DESCRIPTION	PART#
STRUT, MUSTANG ('79-'04)	30022
COIL-OVER KIT, MUSTANG ('79-'04)	29022

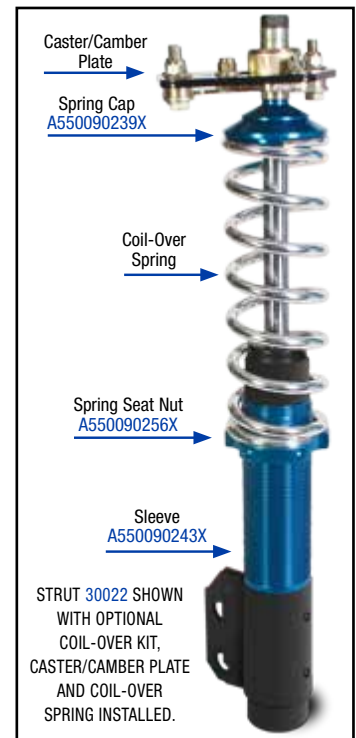

CASTER/CAMBER PLATES



40022 - FITS '79-'89 MUSTANG



40023 - FITS '90-'93 MUSTANG



40024 - FITS '94-'04 MUSTANG



40025 - FITS '05-'11 MUSTANG

DESCRIPTION	PART#
CASTER/CAMBER PLATES, MUSTANG ('79-'89)	40022
CASTER/CAMBER PLATES, MUSTANG ('90-'93)	40023

DESCRIPTION	PART#
CASTER/CAMBER PLATES, MUSTANG ('94-'04)	40024
CASTER/CAMBER PLATES, MUSTANG ('05-'11)	40025

SHAWN PEVLOR

“My car has been deadly consistent since switching to “AFCO by Menscer” struts and shocks. From track-to-track, I am able to make more fast passes due to the amount of adjustment and control I get from these parts. My B.E.S. powered Mustang with “AFCO by Menscer” suspension components is the best race car I’ve ever owned.”



DRAG STRUTS

**Best Wheelie Control
Valving In The Market!**

CHEVROLET CAMARO ADJUSTABLE STRUTS

After the tremendous success of our '79-'04 Mustang Strut, AFCO has expanded this technology for even more offerings. In most applications and classes, controlling weight transfer is key to making successful passes. Racers and chassis builders across the market requested a strut that can be used to control front end travel hydraulically instead of mechanically with a chain or cable. The engineering team at AFCO nailed it. The AFCO Big Gun Strut offers tuners the ability to "lock down" the front suspension to create a smooth weight transfer event.

- Double adjustable design-dial in your chassis, click-by-click.
- Best front-end control on the market.
- Fully independent compression and rebound adjustments.
- 35mm piston diameter; up to 37% larger than the competition for superior fluid control and consistency.
- Indexable compression adjuster for increased clearance options at the base of the strut.
- Rebuildable and revalvable as needed; widest possible range in the industry.
- CAD designed and FEA optimized.



30031
'82-'92 CAMARO

30032
'10-'15 CAMARO

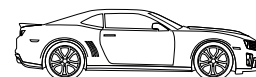
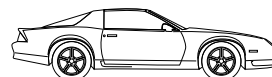

DESCRIPTION	PART #
'82-'92 CAMARO STRUT*	30031
'10-'15 CAMARO STRUT*	30032

* AFTERMARKET CASTER/CAMBER PLATES REQUIRED FOR INSTALLATION (SEE PAGE 15). DRAG STRUTS DO NOT HAVE PROVISIONS FOR SWAY BAR MOUNTS.



**LOCKING COIL-OVER
KIT INCLUDED**

'10 - '15 CAMARO REAR SHOCK

The 32 Series Double Adjustable Monotube Shocks are specifically valved so chassis tuners can better control the "hit" to the tire. Drag radial competitors require a unique valving package to control the rear suspension and properly apply the radial tire to the track. Choose this series of shocks for the ultimate control off the line and superior traction down track.

- Double adjustable - broad range of adjustment.
- Large piston provides superior launch and down track stability.
- Gas pressure eliminates cavitation and allows shock to recover faster.
- To be used with AFCO Rear Shock Mounts (550000857).



SHOCK 3250R
SHOWN WITH
COIL-OVER SPRING
INSTALLED.

DESCRIPTION	PART#
CAMARO REAR SHOCK ('10-'15)	3250R

CASTER/CAMBER PLATES



40026
'10-'15 CAMARO
CASTER/CAMBER
PLATES



550000857
REAR '11-'15 CAMARO
SHOCK MOUNTS
(CONVERTS MOUNTING TO
BEARING/BEARING.)



550000310
REAR '10-'15
CAMARO SHOCK
EYELET BUSHINGS

DESCRIPTION	PART #
CASTER/CAMBER PLATES, CAMARO ('10-'15) (PAIR)	40026
CAMARO REAR SHOCK MOUNT ('10-'15) (PAIR)*	550000857
CAMARO REAR SHOCK BUSHINGS ('10-'15) (PAIR)	550000310
*MUST USE 5" STROKE SHOCK	

BILL TROVATO

"I've been racing a long time and recognize value when I see it. I switched to AFCO and can make adjustments that I can feel in the car. They definitely helped my program!"



DOMINATOR

NEW!

The Best Shock Choice For Maximum Performance!

4-WAY ADJUSTABLE

The engineers at AFCO designed the new 4-way shock program with performance and function in mind. This shock series features the same traction enhancing technology found in all AFCO Shocks, but is fully high and low speed adjustable on both compression and rebound damping. Consistency is improved by the recirculating, single circuit valve design. Unlike other adjustable shocks, hysteresis is minimized and remains low regardless of the adjustment position or range. This allows for a wide adjustment range without sacrificing performance. The shock can be configured to fit most coil-over applications. Its compressed and extended lengths are in line with industry standards and the adjustable eyelet and canister position allows for maximum mounting clearance. This series is ideal for everyone from the over-achieving sportsman to the professional racer.

- Fully independent high and low speed adjustments for both compression and rebound.
- All adjustments affect the pressure drop across the main piston.
- Single-circuit, recirculating design allows for large adjustment range with extremely low hysteresis.
- Solid main piston allows for reduced gas charge pressure without the risk of cavitation.
- Nitrogen bladder design enhances response and reduces "stiction" induced hysteresis and eliminates cavitation.
- Compact - compressed and extended lengths comparable to most standard shock lengths on the market.
- Universal mounting design has 32 different options.
 - 8 position, indexable gas canister.
 - 4 position, indexable body eyelet.
- Custom tuning to meet the racer's needs.
- Controls tire shake and eliminates chassis ratcheting.

COIL-OVER KIT INCLUDED



4-WAY ADJUSTABLE!

Take control of your shock program and give your car the control it needs! AFCO's 4-Way Adjustable Shocks complete your comprehensive suspension program!

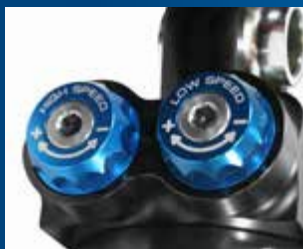

HIGH SPEED COMPRESSION ADJUSTMENT.
LOW SPEED COMPRESSION ADJUSTMENT.



HIGH SPEED REBOUND ADJUSTMENT.



LOW SPEED REBOUND ADJUSTMENT.

QUALITY YOU CAN EXPECT FROM AFCO!



4-WAY DOMINATOR SERIES SHOCK

DESCRIPTION	TRAVEL	DIMENSIONS	PART #
4" STROKE 4 WAY SHOCK	4"	10.00" COMP X 14.00" EXT.	18104
5" STROKE 4 WAY SHOCK	5"	11.00" COMP X 16.00" EXT.	18105
6" STROKE 4 WAY SHOCK	6"	12.00" COMP X 18.00" EXT.	18106
7" STROKE 4 WAY SHOCK	7"	13.00" COMP X 20.00" EXT.	18107
8" STROKE 4 WAY SHOCK	8"	14.00" COMP X 22.00" EXT.	18108

TOOLS & SUPPLIES

SPANNER WRENCH

Used for adjusting coil-over nuts.



DESCRIPTION	PART #
SPANNER WRENCH	20110

COIL-OVER ADJUSTER NUT BEARING KIT

Sold in pairs.



DESCRIPTION	PART #
C/O NUT BEARING KIT	20144

GAS SHOCK INFLATION GAUGE



DESCRIPTION	PART #
0-300 PSI GAUGE	AGAUGE

DON O'NEAL

"AFCO Racing Products has always supported my racing program. The products are very user-friendly and have helped me maximize my combination. We race to win together!"



BIG GUN "SLICKS"

Best For Slick Tire 1,500+ HP Applications!

DOUBLE ADJUSTABLE

MONOTUBE ALUMINUM CANISTER

PRO STREET, OUTLAW 10.5, TOP SPORTSMAN, BIG DOG, SUPER QUICK, PRO 5.0, SSO, TOP DRAGSTERS & OTHERS

- Big Gun Valving - Specifically valved for high horsepower applications.
- Large piston provides superior launch stability.
- Gas pressure eliminates cavitation and allows shock to recover faster.
- Double Adjustable - broad range of adjustment, click-by-click.

BROAD RANGE OF ADJUSTMENT!



COMPRESSION ADJUSTMENT.



REBOUND ADJUSTMENT.



Coil-over kit included.

PART# 20135D

BIG GUN REAR SHOCKS

BIG GUN	COMP	EXTENDED	SUGGESTED SPRING HEIGHT	SUGGESTED RIDE HEIGHT	PART #
4" STROKE COIL-OVER	11.20"	15.20"	8"	13.00"-13.50"	3240BG
5" STROKE COIL-OVER	12.20"	17.20"	10"-12"	13.50"-14.50"	3250BG
6" STROKE COIL-OVER	13.20"	19.20"	12"-14"	14.50"-16.50"	3260BG
7" STROKE COIL-OVER	14.20"	21.20"	14"	15.50"-18.50"	3270BG

THE ABOVE SHOCKS COME WITH A 1" WIDE BEARING.



Standard 1/2" ID
1" Wide Bearing
PART# 1007X

ACCESSORIES

CANISTER MOUNTS

DESCRIPTION	PART #
1-1/4" CAN. MOUNT	50330
1-3/8"	50329
1-1/2"	50331
1-3/4"	50332



GAS SHOCK INFLATION GAUGES

DESCRIPTION	PART #
GAS PRESSURE GAUGE	AGAUGE



SPRING SOLD SEPARATELY. SEE PAGE 42-45.

PETER BIONDO MONTEITH RACING



"When I pull up to the line with a National event final round at stake, I depend on AFCO Shocks to help transfer the weight to the rear wheels. For fifteen years now, AFCO gets me pointed toward the win light."

7 NHRA World Championships
48+ NHRA National Event Wins

BIG GUN X "RADIALS"

**Best For Radial Tire
1,500+ HP Applications!**

DOUBLE ADJUSTABLE

MONOTUBE ALUMINUM CANISTER

X275, LDR, NITROUS X, ULTRA STREET & MX235

The Big Gun X Series Double Adjustable Monotube shocks are specifically valved for extremely high horsepower drag radial tire equipped applications. With this valving package, chassis tuners can better control the "hit" to the tire using this series of shocks. Drag radial competitors require a unique valving package to control the rear suspension and properly apply the radial tire to the track. Don't "drive thru" your shocks with that big power! **If you have 1,500+ horsepower and are on a drag radial tire, or are using stock suspension, this is the valving package you need to complement your race program.** Choose this series of shocks for the ultimate control off the line and superior traction down track. For quicker adjustments, mount your AFCO shocks upside-down for unsprung weight savings and easier access to the rebound adjuster.

- *Double Adjustable - broad range of adjustment, click-by-click.*
- *Big Gun X Valving - specifically valved for high horsepower radial tire applications.*
- *Large piston provides superior launch and down track stability.*
- *Gas pressure eliminates cavitation and allows shock to recover faster.*

BROAD RANGE OF ADJUSTMENT!



COMPRESSION ADJUSTMENT.

REBOUND ADJUSTMENT.



Coil-over kit included.

PART# 20135D

BIG GUN X REAR SHOCKS

BIG GUN	COMP	EXTENDED	SUGGESTED SPRING HEIGHT	SUGGESTED RIDE HEIGHT	PART #
4" STROKE COIL-OVER	11.20"	15.20"	8"	13.00"-13.50"	3240BGX
5" STROKE COIL-OVER	12.20"	17.20"	10"-12"	13.50"-14.50"	3250BGX
6" STROKE COIL-OVER	13.20"	19.20"	12"-14"	14.50"-16.50"	3260BGX
7" STROKE COIL-OVER	14.20"	21.20"	14"	15.50"-18.50"	3270BGX

THE ABOVE SHOCKS COME WITH A 1" WIDE BEARING.



Standard 1/2" ID
1" Wide Bearing
PART# 1007X



SPRING SOLD SEPARATELY. SEE PAGE 42-45.

RAY BULACH BULACH RACING



T-56 World Record Holder

"My new BGX shocks from AFCO and BGR have made a huge improvement in the performance of my race car. The tunability and control is amazing, and the time slips have backed it up pass after pass. AFCO's products and the support we get from them and the BGR Army are second to none. They made me a believer!"



BIG GUN "SLICKS"

DOUBLE ADJUSTABLE

TWIN TUBE ALUMINUM

ULTRA/ULTIMATE STREET, TOP SPORTSMAN, BIG DOG, SUPER QUICK, PRO 5.0, SSO & OTHERS

The "Big Gun" shocks are specifically valved for high horsepower applications. Both small tire and big tire cars can better control the "hit" to the tire with this series of shocks. Don't "drive through" your shocks with that big power — choose this series of shocks for the ultimate control off the line.

- Widest range of adjustment on the market.
- Make a click and feel the change.
- 100% dyno tested.

BROAD RANGE OF ADJUSTMENT!



COMPRESSION ADJUSTMENT.



REBOUND ADJUSTMENT.

Coil-over kit included.



PART# 20135D

Big Gun Twin Tube Rear Shocks

T2 (TWIN-TUBE)	COMP	EXTENDED	SUGGESTED SPRING HEIGHT	SUGGESTED RIDE HEIGHT	PART #
4" STROKE COIL-OVER	11"	14.92"	8"	12.25"-13.25"	3840BG
5" STROKE COIL-OVER	12"	16.92"	10"-12"	13.75"-14.75"	3850BG
6" STROKE COIL-OVER	13"	18.92"	12"-14"	14.75"-16.75"	3860BG
7" STROKE COIL-OVER	14"	20.92"	14"	15.50"-18.50"	3870BG

THE ABOVE SHOCKS COME WITH A 1" WIDE BEARING.



Standard 1/2" ID 1" Wide Bearing PART# 1007X

Best For Slick Tire
1,000-1,500 HP
Applications!



SPRING SOLD SEPARATELY. SEE PAGE 42-45.

AL & GREG PARADIGM AUTO

"AFco Big Gun Shocks are our key to putting the power to the ground. Adjustability and customer service are second to none!"



BIG GUN X "RADIALS"

**Best For Radial Tire
1,000-1,500 HP
Applications!**

DOUBLE ADJUSTABLE

TWIN TUBE ALUMINUM

X275, LDR, NITROUS X, ULTRA STREET & MX235

The Big Gun X Double Adjustable Twin Tube shocks are specifically valved for high horsepower drag radial tire equipped applications. Drag radial competitors require a unique valving package to control the rear suspension and properly apply the radial tire to the track. Superior traction is achieved through a high flow piston that delivers consistent performance, pass after pass. **If you have 1,000 - 1,500 horsepower and are on a drag radial tire, this is the valving package you need to complement your race program.** For quicker adjustments, mount your AFCO shocks upside down for unsprung weight savings and ease in accessing the rebound adjuster.

- Double Adjustable - broadest range of adjustment on the market.
- Big Gun X Valving - specifically valved for high horsepower drag radial tire applications.
- Great for BIG or SMALL tire door slammers.
- Rebuildable and revalvable.

BROAD RANGE OF ADJUSTMENT!



COMPRESSION ADJUSTMENT.



REBOUND ADJUSTMENT.

Coil-over kit included.



PART# 20135D

Big Gun X Rear Shocks

BGX TWIN-TUBE	COMP	EXTENDED	SUGGESTED SPRING HEIGHT	SUGGESTED RIDE HEIGHT	PART #
4" STROKE COIL-OVER	11"	14.92"	8"	12.25"-13.25"	3840BGX
5" STROKE COIL-OVER	12"	16.92"	10"-12"	13.75"-14.75"	3850BGX
6" STROKE COIL-OVER	13"	18.92"	12"-14"	14.75"-16.75"	3860BGX
7" STROKE COIL-OVER	14"	20.92"	14"	15.50"-18.50"	3870BGX

THE ABOVE SHOCKS COME WITH A 1/2" WIDE BEARING.



Standard 1/2" ID
1" Wide Bearing
PART# 1007X

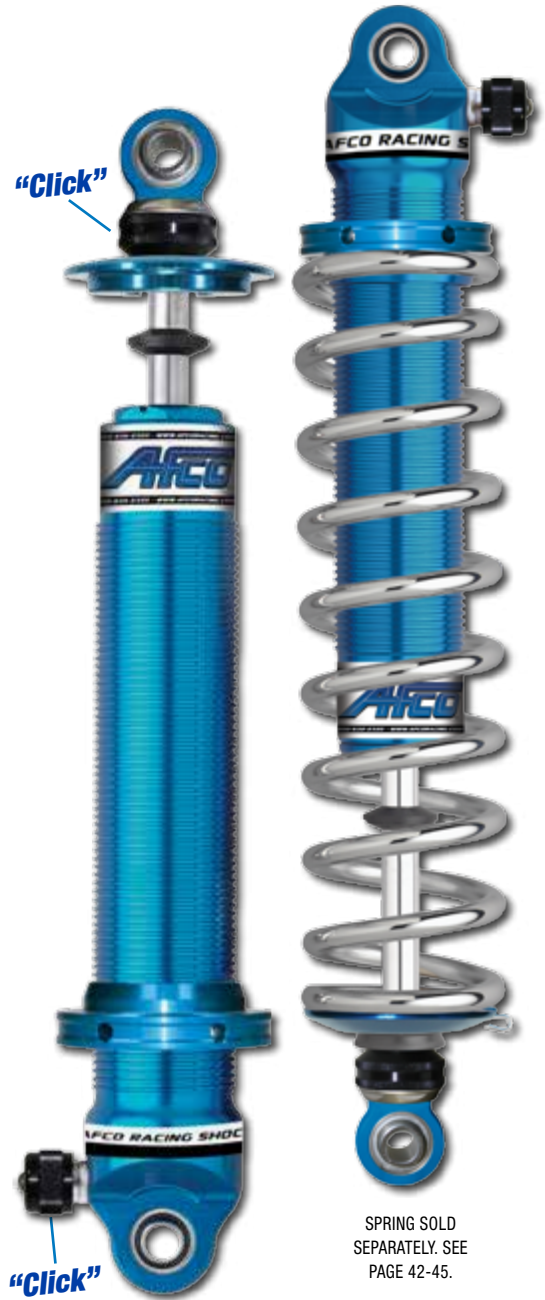

SPRING SOLD SEPARATELY. SEE PAGE 42-45.



Nick McGrath/Kevin Stevens
- Straightline Performance

ELIMINATOR

ADJUSTABLE COIL-OVER SHOCKS

Best For Cars Up To 1,000 HP!

TWIN TUBE ALUMINUM

STOCK MOUNT APPLICATION GUIDE - SEE PAGES 24-25.

AFCO ELIMINATOR Twin Tube Adjustable Shocks are built specifically for drag racing. Our onboard data acquisition systems help us know what your car is doing every 0.001 of a second. We've engineered the ELIMINATOR to control it at every point. This gives you, the racer, unsurpassed traction.

DOUBLE ADJUSTABLE ELIMINATOR

AFCO DOUBLE Adjustable Shocks are the ultimate tool in the chassis tuner's arsenal. The **DOUBLE** adjustments of both compression and rebound damping are completely independent. Changing the setting of one has no affect on the setting of the other. By allowing full control over both compression and rebound forces, this shock gives the tuner the ability to fine tune every aspect of chassis movement to provide the ultimate in acceleration control and overall driveability.

- Widest range of adjustment on the market.
- Make a click and feel the change.
- 100% dyno tested.

STROKE	COMP	EXT	SUGGESTED SPRING HEIGHT	SUGGESTED RIDE HEIGHT	PART #
3"	10"	12.90"	7"	10.75"-11.25"	3830
4"	11"	14.90"	7"-8"	12.25"-13.50"	3840
4"	10.18"	14.08"	7"-8"	11.50"-12.50"	3840-Z
5"	12"	16.90"	10"-12"	13.50"-4.75"	3850
6"	13"	18.90"	12"-14"	14.75"-16.00"	3860
7"	14"	20.90"	14"	16.00"-18.50"	3870
9"	16"	24.90"	14"	18"-20"	3890

THE ABOVE SHOCKS COME WITH 1" WIDE BEARINGS.

Decreases length by .820". Available for all shocks. Built to order.



Z ROD END



Standard 1/2" ID 1" Wide Bearing PART# 1007X

Coil-over kit included.



PART# 20135D

SPRING SOLD SEPARATELY. SEE PAGE 42-45.



SINGLE ADJUSTABLE ELIMINATOR

AFCO SINGLE Adjustable Shocks are an economical alternative to the fully double adjustable design. The **SINGLE** adjustment gives you the ability to adjust rebound damping control without affecting the compression damping characteristics of the shock. The rebound adjustment is the most critical in tuning a drag racing setup. This adjustment allows the tuner to dial in the separation of the chassis and keep the tires planted during the critical first 60' down the track.

- Extension adjustable only - will not affect compression.
- Widest range of adjustment on the market.
- Make a click and feel the change.
- 100% dyno tested.

STROKE	COMP	EXT	SUGGESTED SPRING HEIGHT	SUGGESTED RIDE HEIGHT	PART #
3"	10"	12.90"	7"	10.75"-11.25"	3835
4"	11"	14.90"	7"-8"	12"-13.50"	3845
5"	12"	16.90"	10"-12"	13.25"-14.50"	3855
7"	14"	20.90"	14"	15"-18"	3875
9"	16"	24.90"	14"	18"-20"	3895

THE ABOVE SHOCKS COME WITH 1" WIDE BEARINGS.



Standard 1/2" ID 1" Wide Bearing PART# 1007X

Coil-over kit included.



PART# 20135D

SPRING SOLD SEPARATELY. SEE PAGE 42-45.



ELIMINATOR "BNC"

ADJUSTABLE STOCK MOUNT SHOCKS

**Great For
Bounce
Control!**

TWIN TUBE ALUMINUM

NEW!

STOCK, SUPER STOCK, OUTLAW 10.5, X275, TRUE STREET & OTHERS

The ELIMINATOR "BNC" valving shocks eliminate bounce. No other shock on the market offers this much performance and control! The BNC shocks are designed to better absorb the impact of the car after a wheel stand launch. They can be used in coil-over applications with the optional kit.

AFCO's 3840F/BNCBG has been developed to control violent launches. No shock provides more clamp force. Keep your front end down with AFCO.



SPRING SOLD SEPARATELY. SEE PAGE 42-45.

BNC FRONT SHOCKS

STROKE	COMP	EXT	APPLICATION	PART #
4" STROKE	10.25"	14.15"	'67-'69 CAMARO & OTHER GM (FRONT)*	3840F/BNC
4" STROKE	10.25"	14.15"	'67-'69 CAMARO & OTHER GM (FRONT)*	3840F/BNC2
4" STROKE	10.25"	14.15"	'67-'69 CAMARO & OTHER GM (FRONT)*	3840F/BNCBG
5" STROKE	11.25"	16.15"	GM FULL SIZE*	3850F/BNC

*COIL-OVER KITS SOLD SEPARATELY (SEE PAGE 38).

NEW!



Standard 1/2" ID
1" Wide Bearing
PART# 1007X

STROKE	COMP	EXT	APPLICATION	PART #
7" STROKE	14"	20.90"	'93-'02 CAMARO / FIREBIRD (FRONT)*	3870F/BNC*
7" STROKE	14"	20.90"	'93-'02 CAMARO / FIREBIRD (FRONT)*	3870F/BNC2*

*INCLUDES COIL-OVER KIT.

NEW!

ACCESSORIES DESCRIPTION	PART #
OPTIONAL COIL-OVER KIT (MOUNTS SPRING TO SHOCK)	20135D
GM WELD-IN LOWER SHOCK MOUNT	A550090108X

APPLICATION GUIDE - SEE PAGES 24-25.

BNC2 DRAG VALVING

AFCO is proud to introduce a refresh to its bounce control valving "BNC". The improved bounce control valving is targeted at nose heavy, wheel standing door cars. The new "BNC2" valving continues the tradition of smooth landings with an even more aggressive valve package. The key benefits are that the car lands softly and doesn't damage oil pans or headers, or scrub off E.T. This allows cleaner passes to be made. For the ultimate in front end shock technology, chose AFCO's BNC2 valving. This valve package can be installed in any new or existing shock as an upgrade.

NEW!



ELIMINATOR STOCK MOUNT APPLICATION GUIDE

FORD	FRONT		REAR	
	SINGLE	DOUBLE	SINGLE	DOUBLE
'72-'79 FAIRLANE-TORINO	N/A	N/A	3875R ①	3870R ①
'66-'70 FALCON	N/A	N/A	3875R ①	3870R ①
'65-'86 FULL-SIZE	N/A	N/A	3875R ①	3870R ①
'57-'59 FULL-SIZE	N/A	N/A	N/A	N/A
'81-'82 GRANADA	N/A	N/A	3875R	3870R
'79-'93 MUSTANG	N/A	(SEE PAGE 12)	3875R	3870R
'72-'79 RANCHERO	N/A	N/A	3875R ①	3870R ①
'67-'79 T-BIRD	N/A	N/A	3875R ①	3870R ①
'05-'14 MUSTANG	N/A	(SEE PAGE 12)	3875R-3	3870R-3

MERCURY	FRONT		REAR	
	SINGLE	DOUBLE	SINGLE	DOUBLE
'79-'86 CAPRI	N/A	N/A	3875R	3870R
'80-'82 COUGAR	N/A	N/A	3875R	3870R
'74-'79 COUGAR	N/A	N/A	3875R ①	3870R ①
'65-'86 FULL-SIZE	N/A	N/A	3875R ①	3870R ①
'72-'76 MONTEGO	N/A	N/A	3875R ①	3870R ①

CHRYSLER	FRONT		REAR	
	SINGLE	DOUBLE	SINGLE	DOUBLE
'74-'78 FULL-SIZE	N/A	N/A	3895M ①	3890M ①
'57-'64 FULL-SIZE	N/A	N/A	3895M ①	3890M ①

DODGE	FRONT		REAR	
	SINGLE	DOUBLE	SINGLE	DOUBLE
'70-'74 CHALLENGER	3855M ①	3850M ①	3895M ①	3890M ①
'73-'78 CHARGER, CORONET	3855M ①	3850M ①	N/A	N/A
'65-'72 CHARGER, CORONET	3855M ①	3850M ①	3895M ①	3890M ①
'75-'76 CORDOBA	N/A	N/A	3895M ①	3890M ①
'77-'79 MAGNUM	3855M ①	3850M ①	3895M ①	3890M ①
'64-'76 DART	3855M ①	3850M ①	3895M	3890M
'79-'92 TRUCK	3845F ①	3840F ①	N/A	N/A
'62-'78 MONACO	3855M ①	3850M ①	3895M ①	3890M ①
'61-'62 MONACO	N/A	N/A	3895M ①	3890M ①

PLYMOUTH	FRONT		REAR	
	SINGLE	DOUBLE	SINGLE	DOUBLE
'64-'74 BARRACUDA	3855M ①	3850M ①	3895M ①	3890M ①
'73-'74 SATELLITE, BELVEDERE	N/A	N/A	3895M ①	3890M ①
'65-'72 SATELLITE, BELVEDERE	3855M ①	3850M ①	3895M ①	3890M ①
'62-'70 SAVOY, FURY, BELVEDERE	3855M ①	3850M ①	3895M ①	3890M ①
'67-'70 GTX	3855M ①	3850M ①	3895M ①	3890M ①
'68-'75 ROADRUNNER	3855M ①	3850M ①	3895M ①	3890M ①
'64-'76 DUSTER, VALIANT	3855M ①	3850M ①	3895M	3890M

CHEVROLET (BUICK, OLDS, PONT., EQUIV.)	FRONT		REAR	
	SINGLE	DOUBLE	SINGLE	DOUBLE
'82-'96 BLAZER, S-10	3845F ①	3840F ①	3875R-1 ②	3870R-1 ②
'68-'87 EL CAMINO	3845F ①	3840F ①	3875R-1 ②	3870R-1 ②
'64-'67 EL CAMINO	3845F	3840F ①	3875R-1 ②	3870R-1 ②
'10-'15 CAMARO	N/A	(SEE PAGE 14)	N/A	(SEE PAGE 15)
'93-'02 CAMARO	3875F	3870F/BNC OR 3870F/BNC2	3875R ①	3870R ①
'82-'92 CAMARO	N/A	(SEE PAGE 14)	3875R ①	3870R ①
'70-'81 CAMARO	3855F	3850F ①	3875R-2 ②	3870R-2 ②
'67-'69 CAMARO	3845F ①	3840F ①	3875R ①	3870R ①
'68-'83 CHEVELLE, MALIBU	3845F ①	3840F ①	3875R-1 ②	3870R-1 ②
'64-'67 CHEVELLE, MALIBU	3845F	3840F ①	3875R-1 ②	3870R-1 ②
'76-'87 CHEVETTE	N/A	N/A	3875R ①	3870R ①
'74-'79 NOVA	3845F ①	3840F ①	3875R ①	3870R ①
'73 NOVA NON - H.D. REAR	3845F ①	3840F ①	3875F ③	3870F ③
'73 NOVA WITH H.D. REAR	3845F ①	3840F ①	3875R-1 ②	3870R-1 ②
'68-'72 NOVA W / MONOLEAF	3845F ①	3840F ①	3875R-1 ①	3870R-1 ①
'68-'72 NOVA W / MULTILEAF	3845F ①	3840F ①	3875R-1 ②	3870R-1 ②
'62-'67 CHEVY II, NOVA W / MULTILEAF	N/A	N/A	3875R ①	3870R ①
'63-'82 CORVETTE	3845F	3840F ①	N/A	N/A
'53-'62 CORVETTE	N/A	N/A	3875R ①	3870R ①
'65-'86 FULL-SIZE	3845F	3840F ①	3875R-1 ②	3870R-1 ②
'55-'57 FULL-SIZE	3845F	3840F ①	3875R-1 ②	3870R-1 ②
'70-'88 MONTE CARLO	3845F ①	3840F ①	3875R-1 ②	3870R-1 ②
'75-'80 MONZA	3845F ①	3840F ①	3875R-1 ①	3870R-1 ①
'72-'77 VEGA	3845F ①	3840F ①	3875R-1 ①	3870R-1 ①

① Check extended & compressed dimensions. ② May need to "slot" tie bar mount. ③ Mounting point modifications may be needed.

ELIMINATOR STOCK MOUNT APPLICATION GUIDE

The chart shows common applications for AFCO Stock Mount Shocks. **We highly recommend you measure your chassis for proper length and mount points.**

Eliminator Single Adjustable

- Double **3840F**
- Double **3840F/ BNC**
- Double **3840F/BNCBG**
- Single **3845F**

STROKE.....4"
COMP.....10.25"
EXT.....14.15"
BODY MOUNT.....B2
SHAFT MOUNT.....S1



Coil-over hardware kit sold separately (kit # 20135D - See page 38). Can be used as a coil-over with chrome tapered springs (See page 45) sold separately.

- Double **3850M**
- Single **3855M**

STROKE.....5"
COMP.....11.25"
EXT.....16.15"
BODY MOUNT.....B3
SHAFT MOUNT.....S1



Comes with coil-over hardware (20135D).

- Double **3870F/BNC**
- Double **3870F/BNC2**
- Single **3875F**

STROKE.....7"
COMP.....14"
EXT.....19.9"
BODY MOUNT.....B5
SHAFT MOUNT.....S2
SPRING LENGTH.....14"



Comes with coil-over hardware (20135D) and mounting bracket (20146). See page 23 for more info. on BNC & BNC2 valving.

- Double **3870R-1**
- Single **3875R-1**

STROKE.....7"
COMP.....14"
EXT.....20.90"
BODY MOUNT.....B2
SHAFT MOUNT.....S2



Coil-over hardware kit sold separately (kit # 20135D - See page 38).

- Double **3870R**
- Single **3875R**

STROKE.....7"
COMP.....13.25"
EXT.....20.15"
BODY MOUNT.....B3
SHAFT MOUNT.....S1



Coil-over hardware kit sold separately (kit # 20135D - See page 38).

- Double **3870R-2**
- Single **3875R-2**

STROKE.....7"
COMP.....13.25"
EXT.....20.15"
BODY MOUNT.....B2
SHAFT MOUNT.....S1



Coil-over hardware kit sold separately (kit # 20135D - See page 38).

- Double **3890M**
- Single **3895M**

STROKE.....9"
COMP.....16"
EXT.....24.90"
BODY MOUNT.....B4
SHAFT MOUNT.....S2
SPRING LENGTH.....14"



Comes with coil-over hardware (20135D).

REPLACEMENT MOUNTS

B1



20147-2

B2



20147-4

B3



1007X

B4



1080TX

B5



20147-3

With 5/8" bearing

B6



20147-4

S1

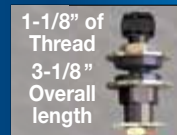

20180-3A

1-3/4" Washers

9/16" Stud

S2

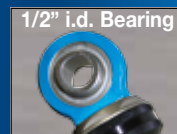

1000

REACTOR

SINGLE ADJUSTABLE SHOCKS

MONOTUBE ALUMINUM

AFCO Single Adjustable Shocks are an economical alternative to the fully double adjustable design. The Single adjustment gives you the ability to adjust rebound damping control without affecting the compression damping characteristics of the shock.

The rebound adjustment is the most critical in tuning a drag racing setup. This adjustment allows the tuner to dial in the separation of the chassis and keep the tires planted during the critical first 60' down the track.

- Gas monotube design for superior tuning and performance.
- Rebound adjustable only - will not bleed over to compression.
- Tune only where you want it.
- 100% dyno tested and serial numbered.

REACTOR COIL-OVER SHOCKS

STROKE	COMP	EXT	SUGGESTED SPRING HEIGHT	RIDE HEIGHT	PART #
4"	11.20"	15.20"	7"-8"	12.25"-13.25"	6845
5"	12.20"	17.20"	10"-12"	13.75"-14.75"	6855
6"	13.20"	19.20"	14"	14.75"-16.75"	6865
7"	14.20"	21.20"	14"	15.5"-18.5"	6875

THE ABOVE SHOCKS COME WITH 1" WIDE BEARINGS.



Coil-over kit included.



**Best Value
On The Market!**



SPRING SOLD SEPARATELY. SEE PAGE 42-45.

"Click"

APPLICATION GUIDE - SEE PAGE 27.

DOUG DUELL



5X NMCA "NSS" Champion.

"AFCO shocks are on all of my drag race cars. I have found these shocks to be made to the highest quality standards and backed up by the staff at AFCO with a level of service that is very racer friendly. AFCO shocks have had a direct effect on my success on the race track and will always be on my cars in the future."



REACTOR STOCK MOUNT APPLICATION GUIDE

FORD	FRONT SINGLE	REAR SINGLE
'72-'79 FAIRLANE-TORINO	N/A	6875R ①
'66-'70 FALCON	N/A	6875R ①
'65-'86 FULL-SIZE	N/A	6875R ①
'57-'59 FULL-SIZE	N/A	N/A
'81-'82 GRANADA	N/A	6875R
'79-'93 MUSTANG	N/A	6875R
'72-'79 RANCHERO	N/A	6875R ①
'67-'79 T-BIRD	N/A	6875R ①

MERCURY	FRONT SINGLE	REAR SINGLE
'79-'86 CAPRI	N/A	6875R
'80-'82 COUGAR	N/A	6875R
'74-'79 COUGAR	N/A	6875R ①
'65-'86 FULL-SIZE	N/A	6875R ①
'72-'76 MONTEGO	N/A	6875R ①

CHRYSLER	FRONT SINGLE	REAR SINGLE
'74-'78 FULL-SIZE	N/A	6895M ①
'57-'64 FULL-SIZE	N/A	6895M ①

DODGE	FRONT SINGLE	REAR SINGLE
'70-'74 CHALLENGER	6855M ①	6895M ①
'73-'78 CHARGER, CORONET	6855M ①	N/A
'65-'72 CHARGER, CORONET	6855M ①	6895M ①
'75-'76 CORDOBA	N/A	6895M ①
'77-'79 MAGNUM	6855M ①	6895M ①
'64-'76 DART	6855M ①	6895M
'79-'92 TRUCK	6845F ①	N/A
'65-'70 MONACO	6855M ①	6895M ①
'75-'77 MONACO	N/A	6895M ①

PLYMOUTH	FRONT SINGLE	REAR SINGLE
'64-'74 BARRACUDA	6855M ①	6895M ①
'73-'74 SATELLITE, BELVEDERE	N/A	6895M ①
'65-'72 SATELLITE, BELVEDERE	6855M ①	6895M ①
'62-'70 SAVOY, FURY, BELVEDERE	6855M ①	6895M ①
'67-'70 GTX	6855M ①	6895M ①
'68-'75 ROADRUNNER	6855M ①	6895M ①
'64-'76 DUSTER, VALIANT	6855M ①	6895M

CHEVROLET	FRONT SINGLE	REAR SINGLE
'82-'96 BLAZER, S-10	6845F ①	6875R-1 ②
'68-'87 EL CAMINO	6845F ①	6875R-1 ②
'64-'67 EL CAMINO	N/A	6875R-1 ②
'93-'02 CAMARO	6875F	6875R ①
'82-'92 CAMARO	N/A	6875R ①
'70-'81 CAMARO	6855F	6875R-2 ②
'67-'69 CAMARO	6845F ①	6875R ①
'68-'83 CHEVELLE, MALIBU	6845F ①	6875R-1 ②
'64-'67 CHEVELLE, MALIBU	N/A	6875R-1 ②
'76-'87 CHEVETTE	N/A	6875R ①
'74-'79 NOVA	6845F ①	6875R-1 ②
'73 NOVA NON - H.D. REAR	6845F ①	6875R-1 ②
'73 NOVA WITH H.D. REAR	6845F ①	6875R-1 ②
'68-'72 NOVA W / MONOLEAF	6845F ①	6875R-1 ①
'68-'72 NOVA W / MULTILEAF	6845F ①	6875R-1 ②
'62-'72 NOVA W / MULTILEAF	N/A	6875R-1 ②
'63-'82 CORVETTE	6845F	N/A
'53-'62 CORVETTE	N/A	6875R ①
'65-'86 FULL-SIZE	6845F	6875R-1 ②
'55-'57 FULL-SIZE	6845F	6875R-1 ②
'70-'88 MONTE CARLO	6845F ①	6875R-1 ②
'75-'80 MONZA	6845F ①	6875R-1 ①
'72-'77 VEGA	6845F ①	6875R-1 ①

① Check extended & compressed dimensions.
 ② May need to "slot" tie bar mount.
 ③ Mounting point modifications may be needed.

6845F WITH BNC VALVING

STROKE.....4"
 COMP.....11.47"
 EXT.....15.42"
 BODY MOUNT.....B2
 SHAFT MOUNT.....S1



Can be used as a coil-over (kit # 20135D - See page 38) with chrome tapered springs (See page 45). Both sold separately.

6855M WITH BNC VALVING

STROKE.....5"
 COMP.....12.47"
 EXT.....17.42"
 BODY MOUNT.....B3
 SHAFT MOUNT.....S1



Comes with coil-over hardware (20135D). Can be used as a coil-over with chrome tapered springs (See page 45) sold separately.

6875F WITH BNC VALVING

STROKE.....7"
 COMP.....15.22"
 EXT.....22.17"
 BODY MOUNT.....B5
 SHAFT MOUNT.....S2



Comes with coil-over hardware (20135D) and mounting bracket (20146).

6875R-1

STROKE.....7"
 COMP.....15.22"
 EXT.....22.17"
 BODY MOUNT.....B2
 SHAFT MOUNT.....S2



Coil-over hardware kit sold separately (kit # 20135D - See page 38).

6875R

STROKE.....7"
 COMP.....14.47"
 EXT.....21.42"
 BODY MOUNT.....B3
 SHAFT MOUNT.....S1



Coil-over hardware kit sold separately (kit # 20135D - See page 38).

6875R-2

STROKE.....7"
 COMP.....14.47"
 EXT.....21.42"
 BODY MOUNT.....B2
 SHAFT MOUNT.....S1



Coil-over hardware kit sold separately (kit # 20135D - See page 38).

6895M

STROKE.....9"
 COMP.....17.22"
 EXT.....26.17"
 BODY MOUNT.....B4
 SHAFT MOUNT.....S2



Comes with coil-over hardware (20135D).

REPLACEMENT MOUNTS

B1



20147-2

B2



20147-4

B3



1007X

1" wide

B4



1080TX

1/2" wide

B5



20147-3

With 5/8" bearing

B6



20147-4

S1



20180-3A

1-3/4" Washers

9/16" Stud

S2

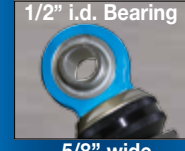

1000

5/8" wide

ELIMINATOR

Convert Your GM To Drag Racing Front Coil-Overs!

FRONT COIL-OVER CONVERSION KITS

AFCO Racing Products is proud to offer a bolt-in coil-over shock kit for drag racing. This kit allows for bolt-in, no-modification installation on most popular GM applications. Some of the features include: easy ride height adjustment, quick corner weight tuning, and pre-load changes to straighten out bad launches, and front end weight reduction. From street and strip to all out drag racing, rely on AFCO to deliver quality suspension components.

- Easy ride height adjustment for the proper stance.
- Quick corner weight and pre-load adjustment to fine tune the launch.
- Reduced front end weight for improved performance.
- BNC valving eliminates bouncing.
- Kit comes complete with (2) shocks, (2) springs, and (2) adjuster nuts.



1967-1969 Camaro/Firebird

	SINGLE ADJUSTABLE	DOUBLE ADJUSTABLE
SMALL BLOCK	4SA/SR350	4DA/SR350
BIG BLOCK	4SA/SR450	4DA/SR450



1970-1981 Camaro/Firebird

	SINGLE ADJUSTABLE	DOUBLE ADJUSTABLE
SMALL BLOCK	5SA/GM300	5DA/GM300
SMALL BLOCK (1-2" LOWERED)	N/A	4DA/GM300
BIG BLOCK	5SA/GM450	5DA/GM450
BIG BLOCK (1-2" LOWERED)	N/A	4DA/GM450



1964-1967 Chevelle

	SINGLE ADJUSTABLE	DOUBLE ADJUSTABLE
SMALL BLOCK	4SA/SR350	4DA/SR350
BIG BLOCK	4SA/SR450	4DA/SR450



1968-1972 Chevelle/Monte Carlo/Malibu

	SINGLE ADJUSTABLE	DOUBLE ADJUSTABLE
SMALL BLOCK	4SA/SR350	4DA/SR350
BIG BLOCK	4SA/SR450	4DA/SR450



1973-1988 Chevelle/Monte Carlo/Malibu

	SINGLE ADJUSTABLE	DOUBLE ADJUSTABLE
SMALL BLOCK	4SA/GM350	4DA/GM350
BIG BLOCK	4SA/GM450	4DA/GM450



1968-1974 Nova

	SINGLE ADJUSTABLE	DOUBLE ADJUSTABLE
SMALL BLOCK	5SA/SR450	5DA/SR450
SMALL BLOCK (1-2" LOWERED)	N/A	4DA/SR450
BIG BLOCK	5SA/SR550	5DA/SR550
BIG BLOCK (1-2" LOWERED)	N/A	4DA/SR550



1975-1979 Nova

	SINGLE ADJUSTABLE	DOUBLE ADJUSTABLE
SMALL BLOCK	5SA/GM300	5DA/GM300
BIG BLOCK	5SA/GM450	5DA/GM450

Eliminator Single-Adjustable Complete Kit:

Eliminator Double-Adjustable Complete Kit:



(2) Shocks, (2) Springs and (2) Adjuster Nuts

PRO STREET & STRIP SHOCKS

Performance And Affordability!

NON-ADJUSTABLE SHOCKS

STEEL COIL-OVER

- Small body lightweight steel shock.
- Popular street / strip valving (non-adjustable).
- Heavy-duty gas design.
- Mounts in standard coil-over location.
- Accepts standard coil-over springs.
- Lowers 60 foot times and improves traction.
- Included coil-over kit accepts "standard" 2-1/2" or 2-5/8" coil.



PRO Street & Strip Non-Adjustable:



DESCRIPTION	COMP	EXT	RECOMMENDED SPRING HEIGHT	PART#
6" W/C-O KIT	11.45"	17.45"	10", 12"	1564A

DAN NORTHROP

"I have used AFCO shocks on my dragsters and my Vega for many years now. AFCO shocks have always performed exactly as I need them to perform. In the highly competitive class that I compete in, thousandths of a second can be the difference between a win and a loss. AFCO shocks have always given me the confidence that my suspension is dialed in to win!"



STREET FIGHTER

NEW!

REBOUND ADJUSTABLE STOCK MOUNT

MONOTUBE STEEL

AFCO is proud to announce that our latest monotube technology is now available in single adjustable stock mount design for many street and strip applications. This new stock mount shock is designed to fit in the OEM locations and offers great control, consistency and tunability. A wide range of rebound adjustability lets you tune your chassis from controlling the initial hit at the rear tires to controlling front weight transfer to keep those tires hooked. Now is the right time invest in higher shock technology. Choose AFCO Racing Shocks!

- Single adjustable (rebound) design for non-coil-over applications.
- Wide range of adjustment with the ability to fine tune your chassis.
- OEM mounting allows for easy install without modifications.
- Rebuildable & revalvable for long life and great performance.
- 1/2" hard chrome piston rod.

*Street Fighter
Single Adjustable:*



REBOUND ADJUSTABLE



Ken Grant



STREET FIGHTER STOCK MOUNT APPLICATION GUIDE

	FRONT NON-WHEEL STANDER	FRONT WHEEL STANDER	REAR
FORD			
'79-'93 MUSTANG	30022*	SEE PG 12	70401
'78-'83 FAIRMONT	30022*	SEE PG 12	70401
'81-'82 GRENADA	30022*	SEE PG 12	70401
'87-'88 THUNDERBIRD	30022*	SEE PG 12	70401
'83-'86 LTD	30022*	SEE PG 12	70401
MERCURY			
'79-'86 CAPRI	30022*	SEE PG 12	70401
'78-'83 ZEPHER	30022*	SEE PG 12	70401
'81-'82 COUGAR	30022*	SEE PG 12	70401
'83-'86 MARQUIS	30022*	SEE PG 12	70401
* 30022 IS A NON-ADJUSTABLE STRUT			
CHEVROLET (AND BUICK/OLDSMOBILE/PONTIAC VARIANTS)			
'82-'04 BLAZER, S-10 (2WD)	70101	70102	70201
'68-'87 EL CAMINO	70101	70102	70201
'64-'67 EL CAMINO	70501	70502	70201
'93-'02 CAMARO	N/A	N/A	70401
'82-'92 CAMARO	N/A	N/A	70401
'70-'81 CAMARO	70501	70502	70301
'67-'69 CAMARO	70101	70102	70401
'68-'83 CHEVELLE, MALIBU	70101	70102	70201
'64-'67 CHEVELLE, MALIBU	70501	70502	70201
'74-'79 NOVA	70101	70102	70201
'73 NOVA NON - H.D. REAR	70101	70102	N/A
'73 NOVA WITH H.D. REAR	70101	70102	70201
'68-'72 NOVA W / MONOLEAF	70101	70102	70201
'68-'72 NOVA W / MULTILEAF	70101	70102	70201
'70-'88 MONTE CARLO	70101	70102	70201
'75-'80 MONZA	70101	70102	N/A
'72-'77 VEGA	70101	70102	N/A



'10 - '11 CAMARO

REVALVEABLE COIL-OVER SHOCKS

**Full Performance
Package For Street
Or Strip**

PERFORMANCE SUSPENSION PACKAGE

- *Caster/camber plates for optimum front end geometry.*
- *Noise isolation for front and rear coil-overs.*
- *AFCO shock valving tuned for a high performance driving experience.*
- *AFCO high performance progressive coil springs on all four corners.*
- *Factory upper and lower shock mounts used for the rear suspension.*
- *Tightens suspension for interstate highway travel while maintaining a quiet & comfortable ride.*
- *Quick steering response and less body roll/float due to improved sway bar technology.*
- *Kit as shipped puts your ride 1" lower vs. stock.*



Front end alignment will be necessary after installation.

CAMARO HIGH PERFORMANCE SUSPENSION PACKAGE

- *2 revalveable coil-over struts.*
- *2 aluminum coil-over shocks.*
- *2 front springs—275 lb./in.*
- *2 rear springs—270 lb./in.*
- *Front sway bar with install kit.*
- *Rear sway bar with install kit.*
- *Caster / Camber Plates.*
- *4 jounce bumpers.*
- *Full color instruction manual.*

DESCRIPTION	PART #
'10-'11 CAMARO HIGH PERFORMANCE SUSPENSION PACKAGE	40027
'10-'11 CAMARO SUSPENSION PACKAGE WITHOUT SWAY BARS	40031
'10-'11 CAMARO SWAY BAR KIT	40032

UMI Performance



PT ELITE

MONOTUBE DOUBLE ADJUSTABLE

PRO TOURING ALUMINUM

On-And-Off Track Performance

The PT ELITE Series offers a unique blend of hydraulic and gas-assisted damping that provides unparalleled on-and-off track performance. It's no wonder the most demanding builds today choose the AFCO PT ELITE Series.

- Remote-mounted canister allows for convenient damping adjustment.
- Broad range of adjustment.
- Custom valving available - every car is different and so are individual performance standards. Let us create the perfect shock for your needs!

PT Elite Double Adjustable:



BROAD RANGE OF ADJUSTMENT!



COMPRESSION ADJUSTMENT.



REBOUND ADJUSTMENT.



MACHINED ALUMINUM BODY.



Coil-over kit included.

PART# 20135C

"Click"

"Click"

STROKE	COMP.	EXT	SUGGESTED SPRING HEIGHT	SUGGESTED RIDE HEIGHT	PART #
4"	10.38"	14.38"	7"-8"	12.25"-12.75"	3240PTCZ
5"	11.38"	16.38"	10"	13.50"-14.75"	3250PTCZ
6"	12.38"	18.38"	12"-14"	13.43"-15.43"	3260PTCZ
7"	13.38"	20.38"	12"-14"	15.50"-17.75"	3270PTCZ

THE ABOVE SHOCKS COME STANDARD WITH THE 1007X BEARING.



Standard Equipment on the Street Machine of the Year 5 Years in a Row!

MOUNTING OPTIONS



Standard 1/2" ID 1" Wide Bearing
PART# 1007X



5/8" ID 1/2" Wide Bearing
Part# 1080TX



1/2" ID 1" Wide Bearing
Part# 1007X (standard)



5/8" ID 1-3/8" Wide Polyurethane Bushings
Part# 20182-1



1/2" ID 1-3/8" Wide Polyurethane Bushings
Part# 20182-2

MUSCLE CAR

NON & SINGLE ADJUSTABLE

TWIN TUBE ALUMINUM

Great Looks And PERFORMANCE!

- High performance handling for every generation.
- Shocks offer velocity sensitive deflective disk valving which optimizes control and handling.
- Adjustable shocks provide countless tuning options giving you full control over your car's handling capabilities.
- 100% dyno-tuned for accuracy and quality.



MACHINED ALUMINUM BODY.



COIL-OVER KIT INCLUDED
PART# 20135C

NON-ADJUSTABLE

STROKE	COMP	EXT	SUGGESTED SPRING	SHOCK LENGTH	5/8" BEARING	1/2" BEARING	5/8" BUSHING
3"	9.32"	12.25"	7"	10"-11"	1330SR5T	1330SRT	1330SRBT
4"	10.32"	14.25"	7"-8"	11"-12"	1340SR5T	1340SRT	1340SRBT
5"	11.32"	16.25"	10"-12"	13"-14"	1350SR5T	1350SRT	1350SRBT
7"	13.32"	20.25"	14"	15.5"-17.5"	1370SR5T	1370SRT	1370SRBT

THE ABOVE SHOCKS COME WITH A 1" WIDE BEARING.

Muscle Car Non-Adjustable:



Muscle Car Single Adjustable:

"Click"

SINGLE ADJUSTABLE

STROKE	COMP	EXT	SUGGESTED SPRING HEIGHT	SUGGESTED RIDE HEIGHT	PART #
3"	9.18"	12.08"	7"	9.93"-10.43"	3835CZ
4"	10.18"	14.08"	7"-8"	11.43"-12.43"	3845CZ
5"	11.18"	16.08"	10"-12"	12.93"-13.43"	3855CZ
6"	12.18"	18.08"	12"-14"	13.43"-15.43"	3865CZ
7"	13.18"	20.08"	14"	14.68"-17.68"	3875CZ

THE ABOVE SHOCKS COME WITH A 1" WIDE BEARING.



FOR REPLACEMENT COIL-OVER KIT, SEE PAGE 38.

APPLICATION GUIDE - SEE PAGES 36-37.

MOUNTING OPTIONS



Standard 1/2" ID 1" Wide Bearing
PART# 1007X



5/8" ID 1/2" Wide Bearing
Part# 1080TX



1/2" ID 1" Wide Bearing
Part# 1007X (standard)



5/8" ID 1-3/8" Wide Polyurethane Bushings
Part# 20182-1



1/2" ID 1-3/8" Wide Polyurethane Bushings
Part# 20182-2

MUSCLE CAR

DOUBLE ADJUSTABLE

TWIN TUBE ALUMINUM

- High performance handling for every generation.
- Shocks offer velocity sensitive deflective disk valving which optimizes control and handling.
- Adjustable shocks provide countless tuning options giving you full control over your car's handling capabilities.
- 100% dyno-tuned for accuracy and quality.

BROAD RANGE OF ADJUSTMENT!

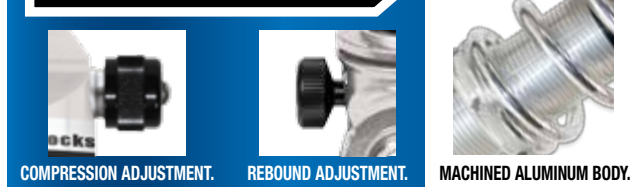

DOUBLE ADJUSTABLE

STROKE	COMP	EXT	SUGGESTED SPRING HEIGHT	SUGGESTED RIDE HEIGHT	PART #
3"	9.18"	12.08"	7"	9.93"-10.43"	3830PTCZ
4"	10.18"	14.08"	7"-8"	11.43"-12.43"	3840PTCZ
5"	11.18"	16.08"	10"-12"	12.93"-13.43"	3850PTCZ
6"	12.18"	18.08"	12"-14"	13.43"-15.43"	3860PTCZ
7"	13.18"	20.08"	14"	14.68"-17.68"	3870PTCZ

THE ABOVE SHOCKS COME WITH A 1" WIDE BEARING.

APPLICATION GUIDE - SEE PAGES 36-37.

Great Looks,
GREAT PERFORMANCE
And CONTROLLABILITY!



MOUNTING OPTIONS



MUSCLE CAR STOCK MOUNT APPLICATION GUIDE

FORD	FRONT SINGLE	FRONT DOUBLE	REAR SINGLE	REAR DOUBLE
'72-'79 FAIRLANE-TORINO	N/A	N/A	3875CR	3870CR
'66-'70 FALCON	N/A	N/A	3875CR	3870CR
'65-'86 FULL-SIZE	N/A	N/A	3875CR	3870CR
'57-'59 FULL-SIZE	N/A	N/A	N/A	N/A
'81-'82 GRANADA	N/A	N/A	3875CR	3870CR
'79-'93 MUSTANG	N/A	N/A	3875CR	3870CR
'72-'79 RANCHERO	N/A	N/A	3875CR	3870CR
'67-'79 T-BIRD	N/A	N/A	3875CR	3870CR
MERCURY	FRONT SINGLE	FRONT DOUBLE	REAR SINGLE	REAR DOUBLE
'79-'86 CAPRI	N/A	N/A	3875CR	3870CR
'80-'82 COUGAR	N/A	N/A	3875CR	3870CR
'74-'79 COUGAR	N/A	N/A	3875CR	3870CR
'65-'86 FULL-SIZE	N/A	N/A	3875CR	3870CR
'72-'76 MONTEGO	N/A	N/A	3875CR	3870CR
CHRYSLER	FRONT SINGLE	FRONT DOUBLE	REAR SINGLE	REAR DOUBLE
'74-'78 FULL-SIZE	N/A	N/A	3895CM	3890CM
'57-'64 FULL-SIZE	N/A	N/A	3895CM	3890CM
DODGE	FRONT SINGLE	FRONT DOUBLE	REAR SINGLE	REAR DOUBLE
'70-'74 CHALLENGER	3855CM	3850CM	3895CM	3890CM
'73-'78 CHARGER, CORONET	3855CM	3850CM	N/A	N/A
'65-'72 CHARGER, CORONET	3855CM	3850CM	3895CM	3890CM
'75-'76 CORDOBA	N/A	N/A	3895CM	3890CM
'77-'79 MAGNUM	3855CM	3850CM	3895CM	3890CM
'64-'76 DART	3855CM	3850CM	3895CM	3890CM
'79-'92 TRUCK	3845CF	3840CF	N/A	N/A
'62-'78 MONACO	3855CM	3850CM	3895CM	3890CM
'61-'62 MONACO	N/A	N/A	3895CM	3890CM
PLYMOUTH	FRONT SINGLE	FRONT DOUBLE	REAR SINGLE	REAR DOUBLE
'64-'74 BARRACUDA	3855CM	3850CM	3895CM	3890CM
'73-'74 SATELLITE, BELVEDERE	N/A	N/A	3895CM	3890CM
'65-'72 SATELLITE, BELVEDERE	3855CM	3850CM	3895CM	3890CM
'62-'70 SAVOY, FURY, BELVEDERE	3855CM	3850CM	3895CM	3890CM
'67-'70 GTX	3855CM	3850CM	3895CM	3890CM
'68-'75 ROADRUNNER	3855CM	3850CM	3895CM	3890CM
'64-'76 DUSTER, VALIANT	3855CM	3850CM	3895CM	3890CM
CHEVROLET (BUICK, OLDS, PONT.)	FRONT SINGLE	FRONT DOUBLE	REAR SINGLE	REAR DOUBLE
'82-'96 BLAZER, S-10	3845CF	3840CF	3875CR-1 ⊕	3870CR-1 ⊕
'68-'87 EL CAMINO	3845CF	3840CF	3875CR-1 ⊕	3870CR-1 ⊕
'64-'67 EL CAMINO	3845CF	3840CF	3875CR-1 ⊕	3870CR-1 ⊕
'93-'02 CAMARO	3875CF	3870CF	3875CR	3870CR
'82-'92 CAMARO	N/A	N/A	3875CR	3870CR
'70-'81 CAMARO	3855CF	3850CF	3875CR-2 ⊕	3870CR-2 ⊕
'67-'69 CAMARO	3845CF	3840CF	3875CR	3870CR
'68-'83 CHEVELLE, MALIBU	3845CF	3840CF	3875CR-1 ⊕	3870CR-1 ⊕
'64-'67 CHEVELLE, MALIBU	3845CF	3840CF	3875CR-1 ⊕	3870CR-1 ⊕
'76-'87 CHEVETTE	N/A	N/A	3875CR	3870CR
'74-'79 NOVA	3845CF	3840CF	3875CR	3870CR
'73 NOVA NON - H.D. REAR	3845CF	3840CF	3875CF ⊕	3870CF ⊕
'73 NOVA WITH H.D. REAR	3845CF	3840CF	3875CR-1 ⊕	3870CR-1 ⊕
'68-'72 NOVA W / MONOLEAF	3845CF	3840CF	3875CR-1	3870CR-1
'68-'72 NOVA W / MULTILEAF	3845CF	3840CF	3875CR-1 ⊕	3870CR-1 ⊕
'62-'67 CHEVY II, NOVA W / MULTILEAF	N/A	N/A	3875CR	3870CR
'63-'82 CORVETTE	3845CF	3840CF	N/A	N/A
'53-'62 CORVETTE	N/A	N/A	3875CR	3870CR
'65-'86 FULL-SIZE	3845CF	3840CF	3875CR-1 ⊕	3870CR-1 ⊕
'55-'57 FULL-SIZE	3845CF	3840CF	3875CR-1 ⊕	3870CR-1 ⊕
'70-'88 MONTE CARLO	3845CF	3840CF	3875CR-1 ⊕	3870CR-1 ⊕
'75-'80 MONZA	3845CF	3840CF	3875CR-1	3870CR-1
'72-'77 VEGA	3845CF	3840CF	3875CR-1	3870CR-1

⊕ May need to "slot" tie bar mount. ⊕ Mounting point modifications may be needed.

MUSCLE CAR STOCK MOUNT APPLICATION GUIDE

DOUBLE
3840CF
3845CF
SINGLE



Coil-over hardware kit sold separately (kit # 20135DC - See page 38). Can be used as a coil-over with chrome tapered springs (See page 45) sold separately.

DOUBLE
3850CM
3855CM
SINGLE



Comes with coil-over hardware (20135DC).

DOUBLE
3870CF
3875CF
SINGLE



Comes with coil-over hardware (20135DC) and mounting bracket (20146). Also available: 3870F/BNC. (See page 23) for more info.

DOUBLE
3870CR-1
3875CR-1
SINGLE



Coil-over hardware kit sold separately (kit # 20135DC - See page 38).

DOUBLE
3870CR
3875CR
SINGLE



Coil-over hardware kit sold separately (kit # 20135DC - See page 38).

DOUBLE
3870CR-2
3875CR-2
SINGLE



Coil-over hardware kit sold separately (kit # 20135DC - See page 38).

DOUBLE
3890CM
3895CM
SINGLE



Comes with coil-over hardware (20135DC).

*Muscle Car
Single Adjustable:*

*Muscle Car
Double Adjustable:*

REPLACEMENT MOUNTS

B1



20147-2

B2



20147-4

B3

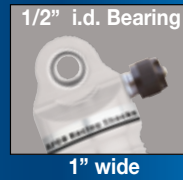

1007X

B4



1080TX

B5



20147-3

With 5/8" bearing

B6



20147-4

S1



20180-3A
9/16" Stud

S2

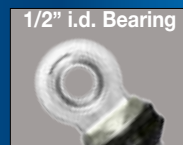

1000

SHOCK ACCESSORIES

COIL-OVER KITS

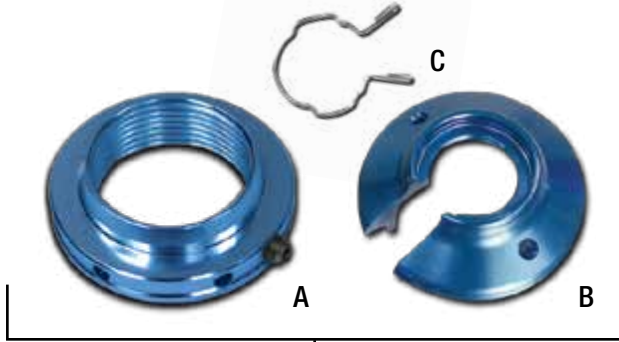

TAPERED CONE KIT: 20135

ALUMINUM THREADED C/O KIT - (BLUE CONICAL CONE)

DESCRIPTION	PART #
TAPERED CONE KIT	20135
A) ADJUSTER NUT ONLY	20131A
B) SPRING SEAT ONLY (TAPERED CONE)	20130
C) SNAP RING ONLY	10243SR

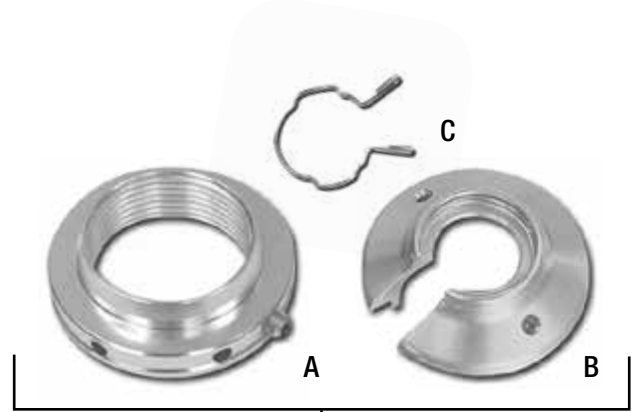

TAPERED CONE KIT: 20135C

ALUMINUM THREADED C/O KIT - (CLEAR CONICAL CONE)

DESCRIPTION	PART #
TAPERED CONE KIT	20135C
A) ADJUSTER NUT ONLY	20131AC
B) SPRING SEAT ONLY (TAPERED CONE)	20130C
C) SNAP RING ONLY	10243SR

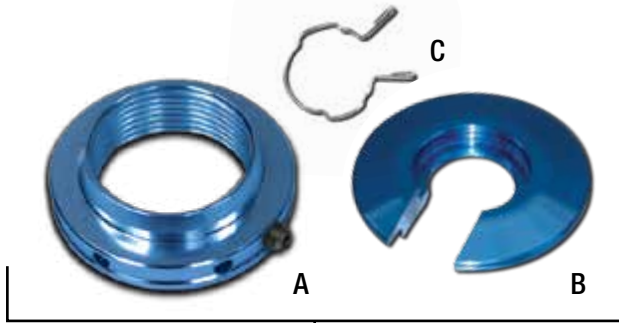

FLAT CONE KIT: 20135D

ALUMINUM THREADED C/O KIT - (BLUE FLAT CONE)

DESCRIPTION	PART #
FLAT CONE KIT	20135D
A) ADJUSTER NUT ONLY	20131A
B) SPRING SEAT ONLY (FLAT CONE)	20128D
C) SNAP CLIP	10243SR

*THIS KIT IS STANDARD IN ALL DRAG COIL-OVER SHOCKS.

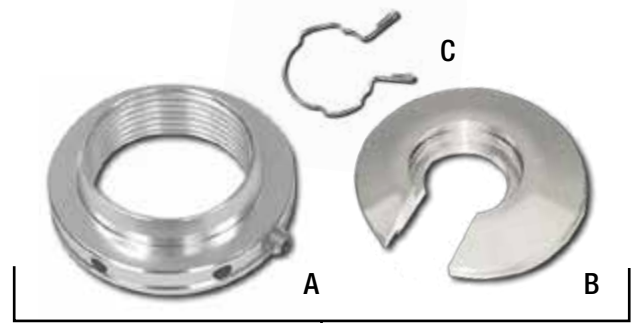

FLAT CONE KIT: 20135DC

ALUMINUM THREADED C/O KIT - (CLEAR FLAT CONE)

DESCRIPTION	PART #
FLAT CONE KIT	20135DC
A) ADJUSTER NUT ONLY	20131AC
B) SPRING SEAT ONLY (FLAT CONE)	20128DC
C) SNAP CLIP	10243SR

ALUMINUM THREADED C/O KIT -- (BLUE CONICAL CONE)

Replacement coil-over kit for 1564A shock.

DESCRIPTION	PART #
TAPERED CONE KIT (REF: 1564A SHOCK)	20125SB
A) ADJUSTER NUT ONLY	20131-1
B) SPRING SEAT ONLY (FLAT CONE)	20122-1
C) 5" SLEEVE	20130SB
D) SNAP RING	10242
E) CONE PIN	10157-1

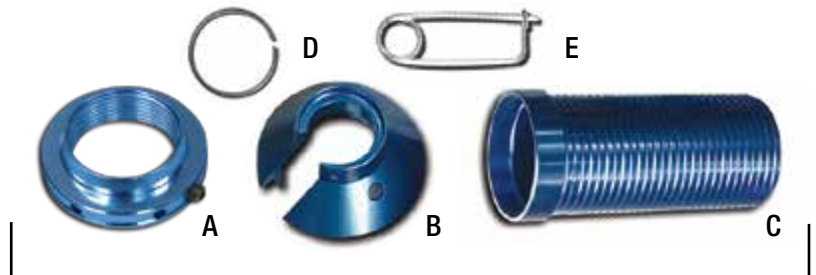

TAPERED CONE KIT: 20125SB

ROD ENDS



DESCRIPTION	PART #
Z STYLE ROD END WITH SIDE KNOB (SILVER)	20172CD
STD. ADJUSTABLE ROD END (SILVER)	20177CD
ADJUSTABLE ROD END 1" EXT. (SILVER)	20177-1CD
ADJUSTABLE ROD END 2" EXT. (SILVER)	20177-2CD



DESCRIPTION	PART #
Z STYLE ROD END WITH SIDE KNOB (BLUE)	20172D
STD. ADJUSTABLE ROD END (BLUE)	20177D
ADJUSTABLE ROD END 1" EXT. (BLUE)	20177-1D
ADJUSTABLE ROD END 2" EXT. (BLUE)	20177-2D

MOUNTING HARDWARE

TIE BAR KIT (BEARING STYLE)

- For all AFCO shocks except K-Series.
- Lower mount for 93+ F-body front shocks & custom applications.
- Uses 1080TX 5/8" bearing.



DESCRIPTION	PART #
TIE BAR KIT	20147-3

TIE BAR KIT

- For all AFCO shocks except K-Series.
- Converts bearing end to a bar mount.
- Lower front GM, rear upper GM, & others.
- Fits O.E. lower control arm.

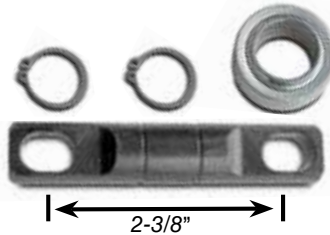

DESCRIPTION	PART #
TIE BAR KIT	20147-2

TIE BAR KIT

- For all AFCO shocks except K-Series.
- Converts bearing end to a bar mount.
- GM rear upper, & others.
- Fits aftermarket lower arms.

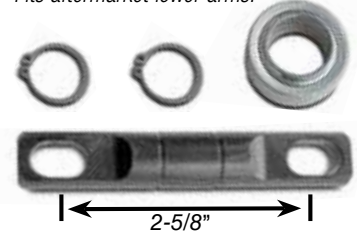

DESCRIPTION	PART #
TIE BAR KIT	20147-4

1993-2002 CAMARO/FIREBIRD SHOCK MOUNT

Converts O.E. upper mount to accept shock eyelet bearing mount. Comes complete with all hardware.



DESCRIPTION	PART #
SHOCK MOUNT 93-02 CAMARO/FIREBIRD	20146

COIL-OVER MOUNTS



DESCRIPTION	PART #
BUSHING ONLY	20136B
UNIVERSAL MOUNT	20137
UNIVERSAL MOUNT - NARROW	20137-1
ROUND TUBE MOUNT	20138
ROLL CAGE MOUNT	20139

SHOCK ACCESSORIES

COIL-OVER TRAVEL INDICATOR

Great tool to determine what your suspension is doing.

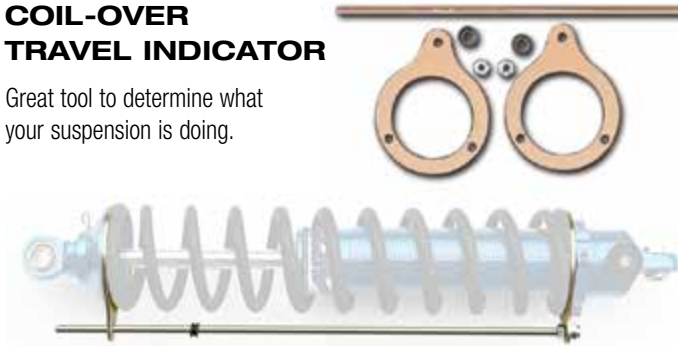

DESCRIPTION	PART #
COIL-OVER TRAVEL INDICATOR	20116

BEARINGS & BUSHINGS



DESCRIPTION	PART #
1/2" I.D. X 0.625" WIDE BEARING (EACH)	1000
1/2" I.D. X 1.06" WIDE BEARING (EACH)	1007X
5/8" I.D. X 0.5" WIDE BEARING (EACH)	1080TX
5/8" I.D. POLYURETHANE BUSHINGS (PAIR)	20182-1
1/2" I.D. POLYURETHANE BUSHINGS (PAIR)	20182-2

COIL-OVER ADJ. NUT BEARING KIT

- Makes adjustments easier.
- Protects shock hardware.



DESCRIPTION	PART #
ADJUSTER NUT BEARING KIT (1 PAIR)	20144

SPANNER WRENCH

Used for adjusting coil-over nuts. It is recommended that spring pressure be relieved before adjusting.

- Fits all makes of shocks.
- Swivel design.



DESCRIPTION	PART #
ADJUSTABLE SPANNER WRENCH	20110

STREET ROD ADJ SHOCK STUD MOUNT ASSY.

- Converts shaft end of shock to a stud top mount.
- For shocks purchased after Nov. 2006 - T2 Kit



DESCRIPTION	PART #
T2 STOCK MOUNT KIT	20180-3A

SPRING RUBBER

Spring rate can change depending on the thickness of the rubber, the location of the rubber, and the type of spring being used. Use with coil springs to increase effective spring rates. Make fast & easy spring rate changes!

- Comes in 7/8" and 3/4" thickness.
- Will fit any brand of 2-1/2" or 2-5/8" coil-over springs, including barrel springs and conventional springs.



DESCRIPTION	PART #
COIL-OVER SPRING RUBBER 3/4"	20185
COIL-OVER SPRING RUBBER 1"	20185-1
SPRING RUBBER FOR 5" OR 5-1/2" CONVENTIONAL COIL	20186

SHOCK BUMPER



DESCRIPTION	PART #
CONE FOR FOAM BUMPER	20173
2.25" SPEEDTHANE BUMPER ONLY	223539
3" SPEEDTHANE BUMPER ONLY	223559

SHOCK MOUNT PINS



DESCRIPTION	PART #
HAIRPIN, 2-1/2"	10156-2
DETENTED, 2-1/2"	10156

GM LOWER WELD-IN RING

- Welds into GM lower control arm to mount AFCO Stock Mount Shocks.



DESCRIPTION	PART #
WELD-IN RING	A550090108X

ADJ. NUT REBUILD KIT



DESCRIPTION	PART #
REBUILD KIT (4 PACK)	20131A-2

CANISTER MOUNTS

Use to mount shock canisters to chassis.

DESCRIPTION	PART #
1-1/4" CANISTER MOUNT	50330
1-3/8"	50329
1-1/2"	50331
1-3/4"	50332
QUICK PINS (4 PACK)	50334



RYAN HAAG

U.S. Nationals Super Stock Champion using AFCO "BNC2" Shocks.



AFCO SUSPENSION

EXTREME CHROME COIL-OVER SPRINGS

- 360° polished wire - An industry EXCLUSIVE!
- Huge inventory and selection - much wider than the competition.
- Market's best guarantee to stay within 1% tolerance of original free height (most other springs have a 5% guarantee).
- Best product presentation in the market: 4 color box, blue cloth protective sleeve.

Extreme Chrome Coil-Over Springs



BEST CHROME SPRING VALUE ON THE MARKET!

Rigorous testing and design have yielded what we believe to be the best chrome spring on the market in regards to look and performance. Whether you are building a purpose-built drag strip machine or a beautiful show cruiser, these springs will provide the strength, durability and show stopping good looks you desire.

We completely polish these springs, inside and out, for 360 degrees of high-quality chrome finish. That's why we have given these springs the "Extreme Chrome" name. Many other chrome spring manufacturers only polish the outside diameter surface of the spring. AFCO wanted a spring that looked amazing from any angle, not just the outside. That's why we've gone the extra mile to provide a superior looking product.

All AFCOIL® springs come with the best satisfaction and performance guarantee in the industry. Rest assured that your AFCOIL® Extreme Chrome Springs will last and perform as expected, or we'll replace them for free.

AFCO OFFERS MORE SPRING RATES AND MORE LENGTHS THAN ANY COMPETITOR

7" EXTREME CHROME

RATE	PART #
300	27300-1CR
350	27350-1CR
400	27400-1CR
450	27450-1CR

8" EXTREME CHROME

RATE	PART #
150	28150-1CR
200	28200-1CR
225	28225-1CR
250	28250-1CR
300	28300-1CR
325	28325-1CR
350	28350-1CR
375	28375-1CR
400	28400-1CR
450	28450-1CR
500	28500-1CR

10" EXTREME CHROME

RATE	PART #
115	23115CR
125	23125CR
140	23140CR
150	23150CR
165	23165CR
175	23175CR
200	23200CR
225	23225CR
250	23250CR
275	23275CR
300	23300CR
325	23325CR
350	23350CR
375	23375CR
400	23400CR
425	23425CR
450	23450CR
500	23500CR
550	23550CR
600	23600CR

12" EXTREME CHROME

RATE	PART #
95	22095CR
110	22110CR
125	22125CR
150	22150CR
175	22175CR
185	22185CR
200	22200CR
225	22225CR
250	22250CR
275	22275CR
300	22300CR
350	22350CR
375	22375CR
400	22400CR
450	22450CR
500	22500CR

14" EXTREME CHROME

RATE	PART #
80	24080CR
100	24100CR
110	24110CR
125	24125CR
150	24150CR
175	24175CR
185	24185CR
200	24200CR
225	24225CR
250	24250CR
275	24275CR
300	24300CR

ULTRA LIGHTWEIGHT BLACK COATED SPRINGS

NEW!

You asked for it and AFCO delivered! Responding to market demand, now you can run high-quality AFCO springs and still get that "blacked out" look!

- **AFCOIL® Springs featuring all new black coating!**
- *Get the performance you are looking for with the tightest tolerances in the industry.*
- *All AFCOILS® are manufactured using ultra-high tensile wire.*
- *These springs are guaranteed not to lose more than 1% of free height.*
- *2-5/8" I.D. design prevents spring lean and bow.*
- *Lifetime Warranty!*

4" BLACK COATED		8" BLACK COATED		10" BLACK COATED		12" BLACK COATED		14" BLACK COATED	
RATE	PART #	RATE	PART #	RATE	PART #	RATE	PART #	RATE	PART #
300	26300B	200	28200-1B	100	23100B	80	22080B	100	24100B
400	26400B	300	28300-1B	125	23125B	100	22100B	125	24125B
600	26600B	375	28375-1B	150	23150B	110	22110B	150	24150B
		425	28425-1B	175	23175B	125	22125B	160	24160B
		450	28450-1B	200	23200B	150	22150B	175	24175B
		475	28475-1B	225	23225B	160	22160B	185	24185B
		500	28500-1B	250	23250B	175	22175B	200	24200B
		550	28550-1B	275	23275B	185	22185B	225	24225B
		575	28575-1B	300	23300B	200	22200B	250	24250B
				325	23325B	225	22225B	275	24275B
				350	23350B	250	22250B	300	24300B
				375	23375B	275	22275B	325	24325B
				400	23400B	300	22300B	350	24350B
				425	23425B	325	22325B		
				450	23450B	350	22350B		
				500	23500B	375	22375B		
				525	23525B	400	22400B		
				550	23550B	425	22425B		
				575	23575B	450	22450B		
				600	23600B	500	22500B		
				650	23650B	525	22525B		
						550	22550B		
						600	22600B		
						650	22650B		

NOTE: ALL 12" & 14" SPRINGS (UP TO 600 LBS./IN.) HAVE EXTRA SHOCK CLEARANCE WOUND INTO THE ACTIVE COILS. THE END COILS STILL TAKE STANDARD COIL-OVER HARDWARE.

Black Coated Springs

MADE IN THE U.S.A.



TAKE-UP SPRING



DESCRIPTION	PART #
2-5/8" ID X 5 LBS.	27005B
2-5/8" SPRING GUIDE	20183-1

AFCOIL LIFETIME WARRANTY

AFCOIL® springs are manufactured using the finest spring material available. They are designed for extended life and consistent performance. They are guaranteed to do the job for which they are designed for as long as they are owned by the original purchaser.

COIL-OVER SPRINGS: AFCO will replace any AFCOIL® spring that ever exceeds the maximum allowable 1% loss of free height from original nominal specification. One way freight is included.

CONVENTIONAL SPRINGS: AFCO will replace any AFCOIL® spring that ever exceeds the maximum allowable 2% loss of free height from original nominal specification. One way freight is included.

1. Guarantee applies to original retail purchaser only.
2. Damaged springs not covered by warranty.
3. Spring must be returned to AFCO freight prepaid along with a copy of the original invoice.
4. No other warranty, either expressed or implied, applies to AFCOIL® springs. (Warranty not valid without invoice.)

SUGGESTED COIL-OVER SPRING RATES

Refer to the rate correction chart if shock is mounted at an angle. Front spring recommendations are targeted at strut front end applications only. (Tube chassis, spindle mount strut design)

FRONT		REAR	
Rate	Total on Front Tires	Rate	Total on Rear Tires
175	800 - 1000 LBS.	80	800 - 1000 LBS.
200	1000 - 1200 LBS.	95	1000 - 1100 LBS.
225	1200 - 1400 LBS.	100	1100 - 1200 LBS.
250	1400 - 1700 LBS.	110	1200 - 1400 LBS.
275	1700 - 1900 LBS.	125	1400 - 1500 LBS.
300	1900 - 2100 LBS.	150	1500 - 1600 LBS.
325	2100 - 2300 LBS.	160	1600 - 1700 LBS.
350	2300 - 2500 LBS.	175	1700 - 1800 LBS.
375	2500 + LBS.	185	1800 - 2000 LBS.

THE ABOVE CHART IS FOR BASELINE RECOMMENDATIONS. FINE TUNING MAY BE REQUIRED. NOTE: CHART IS APPLICABLE ONLY FOR COIL-OVER STRUT APPLICATIONS.

RIDE RATE CORRECTION CHART

WHEN SHOCK AND / OR SPRINGS ARE ANGLED:

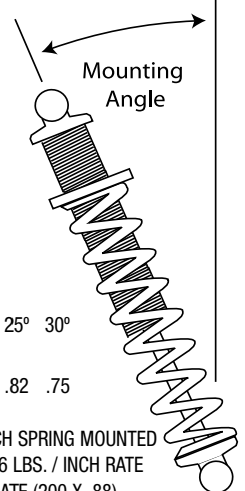

MOUNT ANGLE	10°	15°	20°	25°	30°
RATE MULTIPLIER	.97	.93	.88	.82	.75

EXAMPLE: A 200 LBS. / INCH SPRING MOUNTED AT A 20° ANGLE GIVES A 176 LBS. / INCH RATE WHEN FIGURED FOR RIDE RATE (200 X .88)

ULTRA LIGHTWEIGHT YELLOW COATED SPRINGS

The AFKOIL® yellow coating is recognized for quality and dependable performance. Here's why top racers demand AFKOILS®:

- Manufactured using ultra high tensile wire.
- Tightest tolerances in the industry – Get the performance you deserve.
- Best warranty in the industry – guaranteed not to lose more than 1% of free height.
- 2-5/8" I.D. designed to prevent spring lean and bow.
- Barrel design to prevent spring bow.

Yellow Coated Springs

MADE IN THE U.S.A.



4" YELLOW COATED		8" YELLOW COATED		10" YELLOW COATED		12" YELLOW COATED		14" YELLOW COATED	
RATE	PART #	RATE	PART #	RATE	PART #	RATE	PART #	RATE	PART #
300	26300	300	28300-1	100	23100	100	22100	100	24100
400	26400	425	28425-1	125	23125	125	22125	125	24125
600	26600	475	28475-1	150	23150	150	22150	150	24150
		500	28500-1	200	23200	175	22175	175	24175
				225	23225	185	22185	200	24200
				275	23275	225	22225	225	24225
				350	23350	250	22250	300	24300
				375	23375	275	22275	325	24325
				400	23400	300	22300		
				425	23425	350	22350		
				450	23450	375	22375		
				525	23525	425	22425		
				550	23550	450	22450		
				575	23575	525	22525		
				600	23600	550	22550		
						600	22600		
						650	22650		

NOTE: ALL 12" & 14" SPRINGS (UP TO 600 LBS./IN.) HAVE EXTRA SHOCK CLEARANCE WOUND INTO THE ACTIVE COILS. THE END COILS STILL TAKE STANDARD COIL-OVER HARDWARE.

AFKOIL LIFETIME WARRANTY

AFKOIL® springs are manufactured using the finest spring material available. They are designed for extended life and consistent performance. They are guaranteed to do the job for which they are designed for as long as they are owned by the original purchaser.

COIL-OVER SPRINGS: AFKO will replace any AFKOIL® spring that ever exceeds the maximum allowable 1% loss of free height from original nominal specification. One way freight is included.

CONVENTIONAL SPRINGS: AFKO will replace any AFKOIL® spring that ever exceeds the maximum allowable 2% loss of free height from original nominal specification. One way freight is included.

1. Guarantee applies to original retail purchaser only.
2. Damaged springs not covered by warranty.
3. Spring must be returned to AFKO freight prepaid along with a copy of the original invoice.
4. No other warranty, either expressed or implied, applies to AFKOIL® springs. (Warranty not valid without invoice.)

SUGGESTED COIL-OVER SPRING RATES

Refer to the rate correction chart if shock is mounted at an angle. Front spring recommendations are targeted at strut front end applications only. (Tube chassis, spindle mount strut design)

FRONT		REAR	
Rate	Total on Front Tires	Rate	Total on Rear Tires
175	800-1000 LBS.	80	800-1000 LBS.
200	1000-1200 LBS.	95	1000-1100 LBS.
225	1200-1400 LBS.	100	1100-1200 LBS.
250	1400-1700 LBS.	110	1200-1400 LBS.
275	1700-1900 LBS.	125	1400-1500 LBS.
300	1900-2100 LBS.	150	1500-1600 LBS.
325	2100-2300 LBS.	160	1600-1700 LBS.
350	2300-2500 LBS.	175	1700-1800 LBS.
375	2500+ LBS.	185	1800-2000 LBS.

THE ABOVE CHART IS FOR BASELINE RECOMMENDATIONS. FINE TUNING MAY BE REQUIRED. NOTE: CHART IS APPLICABLE ONLY FOR COIL-OVER STRUT APPLICATIONS.

RIDE RATE CORRECTION CHART

WHEN SHOCK AND / OR SPRINGS ARE ANGLED:

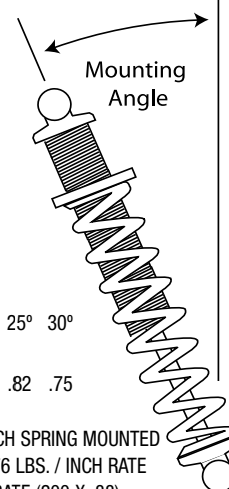

MOUNT ANGLE	10°	15°	20°	25°	30°
RATE MULTIPLIER	.97	.93	.88	.82	.75

EXAMPLE: A 200 LBS. / INCH SPRING MOUNTED AT A 20° ANGLE GIVES A 176 LBS. / INCH RATE WHEN FIGURED FOR RIDE RATE (200 X .88)

CHROME TAPERED SPRINGS

AFCO Racing Product's new chrome tapered spring line is the perfect compliment to a great shock line up. These springs can be used for all popular Mustang II front ends as well as converting your favorite GM muscle car's front suspension to a coil-over shock package. Some of the benefits are: ease of installation, weight savings, and accurate and quick adjustment of your ride height and corner weights for maximum performance.

MADE IN THE U.S.A.

DESCRIPTION	PART NUMBER	TOP I.D.	BOTTOM I.D.	RATE
8" CHROME TAPERED SPRING	A8SR375	3-1/2"	2-1/2"	375
8" CHROME TAPERED SPRING	A8SR500	3-1/2"	2-1/2"	500
8" CHROME TAPERED SPRING	A8SR600	3-1/2"	2-1/2"	600
8" CHROME TAPERED SPRING	A8SR700	3-1/2"	2-1/2"	700
10" CHROME TAPERED SPRING	A10SR350	3-1/2"	2-1/2"	350
10" CHROME TAPERED SPRING	A10SR450	3-1/2"	2-1/2"	450
10" CHROME TAPERED SPRING	A10SR550	3-1/2"	2-1/2"	550
10" CHROME TAPERED SPRING	A10GM300	4"	2-5/8"	300
10" CHROME TAPERED SPRING	A10GM375	4"	2-5/8"	375
10" CHROME TAPERED SPRING	A10GM400	4"	2-5/8"	400
10" CHROME TAPERED SPRING	A10GM450	4"	2-5/8"	450
10" CHROME TAPERED SPRING	A10GM550	4"	2-5/8"	550



SHOWN WITH SHOCK INSTALLED.

SEE PAGE 28 FOR POPULAR APPLICATIONS.



LOW FRICTION BALL JOINTS

AFCO's low friction ball joints are designed with 2 ft. lbs. of resistance, the force required to move the stud of the ball joint. Compare this with standard replacement joints, with up to 50 ft. lbs. of resistance.

- **Only 2 ft. lbs. of resistance and less bind = lower lap times.**
- Improves weight transfer.
- Frees up suspension for more consistent, repeatable chassis tuning.
- Precision-machined to tight tolerances, providing consistent resistance throughout the travel of the ball joint, to deliver consistent performance.
- Road inputs are controlled more effectively by the shock and spring instead of the tire, which improves traction.
- Removes suspension bind and allows shock & spring to have more precise wheel control.
- Meets or exceeds standard ball joint strength.
- Provides more accurate setups during vehicle scaling.
- Lower input steering efforts and faster steering wheel return.
- Extended lengths will raise roll center and improve camber curves.
- Stock appearing.

LOWER BALL JOINTS



UPPER BALL JOINTS



WE'VE EXPANDED OUR SELECTION OF EXTENDED LENGTH LOW FRICTION BALL JOINTS...

PART #	STYLE	BODY	PIN
20032-2LF	4-BOLT UPPER	SAME AS 20032	SAME AS 20032, BUT +1/2" LONGER
20034LF	SCREW IN UPPER/LOWER	SMALL CHRYSLER STYLE (1.83" AT THREAD)	FITS MOST PINTO/MUSTANG II SPINDLES
20034-2LF	SCREW IN UPPER/LOWER	SMALL CHRYSLER STYLE (1.83" AT THREAD)	SAME AS 20034LF, BUT +1/2" LONGER
20036LF	SCREW IN LOWER	BIG CHRYSLER-STYLE (2" DIAMETER AT THREADS)	BIG CHRYSLER STYLE FOR FABRICATED SPINDLES
20038-3LF	PRESS IN LOWER	'64-'72 CHEVELLE, '67-'69 CAMARO AND OTHERS	SAME EXTRA LONG PIN AS 20038-1
20038-4LF	PRESS IN LOWER	'73-'88 CHEVELLE, '70-'02 CAMARO AND OTHERS	SAME EXTRA LONG PIN AS 20038-1



EXTENDED LENGTH BALL JOINT.

STANDARD BALL JOINTS

Not all ball joints are created equal. That's why we choose the best components from the top U.S. manufacturers. There are many different design characteristics and manufacturing processes that account for the quality and performance of ball joints. We choose the best to give you the AFCO Advantage.

BALL JOINT CROSS REFERENCE GUIDE

AFCO PART #	INTERCHANGE #	TYPE
20031	K6024	BOLT-IN
20032	K5208	BOLT-IN
20032-1	K3136	BOLT-IN
20033	K5103	PRESS-IN
20034	K772	SCREW-IN
20034-1	N/A	SCREW-IN
20035	K719	SCREW-IN
20036	K727	SCREW-IN
20037	K5108	BOLT-IN
20038	K6141	PRESS-IN
20038-1	K6117	PRESS-IN
20039	K6145	PRESS-IN
20040	K8259	PRESS-IN

LOWER BALL JOINTS



UPPER BALL JOINTS



APPLICATION GUIDES

GENERAL GUIDE

APPLICATION	UPPER			LOWER		
	INT#*	STANDARD	LOW FRICTION	INT#*	STANDARD	LOW FRICTION
'79-'93 MUSTANG	N/A	N/A	N/A	K8259	20040	N/A
'82-'02 S-10 -2WD, BLAZER -2WD	K5208	20032	20032LF	K6145	20039	20039LF
'93-'02 CAMARO, FIREBIRD, TRANS AM	N/A	N/A	N/A	K6145	20039	20039LF
'82-'92 CAMARO, FIREBIRD, TRANS AM	N/A	N/A	N/A	K6145	20039	20039LF
'70-'81 CAMARO FIREBIRD, TRANS AM	K5208	20032	20032LF	K6145	20039	20039LF
'67-'69 CAMARO FIREBIRD, TRANS AM	K5108	20037	20037LF	K5103	20033	20033LF
'70-'72 MONTE CARLO	K5108	20037	20037LF	K5103	20033	20033LF
'73-'88 MONTE CARLO	K5208	20032	20032LF	K6145	20039	20039LF
'64-'72 CHEVELLE EL CAMINO	K5108	20037	20037LF	K5103	20033	20033LF
'73-'88 CHEVELLE EL CAMINO	K5208	20032	20032LF	K6145	20039	20039LF
'78-'83 MALIBU	K5208	20032	20032LF	K6145	20039	20039LF
'73-'88 CUTLASS	K5208	20032	20032LF	K6145	20039	20039LF
'64-'72 CUTLASS	K5108	20037	20037LF	K5103	20033	20033LF
'73-'87 REGAL	K5208	20032	20032LF	K6145	20039	20039LF
'73-'88 GRAND PRIX	K5208	20032	20032LF	K6145	20039	20039LF
'73-'82 LEMANS GTO	K5208	20032	20032LF	K6145	20039	20039LF
'64-'72 LEMANS GTO	K5108	20037	20037LF	K5103	20033	20033LF
'71-'76 CAPRICE**	K5208	20032	20032LF	K6141	20038	20038LF
'77-'94 CAPRICE**	K5208	20032	20032LF	K6145	20039	20039LF
'94-'96 IMPALA SS	K5208	20032	20032LF	K6145	20039	20039LF
'75-'79 NOVA	K5208	20032	20032LF	K6145	20039	20039LF
'68-'74 NOVA	K5108	20037	20037LF	K5103	20033	20033LF



*INTERCHANGE NUMBER USED BY OTHER MANUFACTURERS. **ALSO FITS IMPALA, BELAIR, BISCAYNE EXC WAGON.

RACING & HYBRIDS GUIDE

UPPER BALL JOINTS APPLICATION	INT#*	STANDARD	LOW FRICT.
SAME BOLT PATTERN AS 20032; LONGER STUD USED TO RAISE THE ROLL CENTER	•	•	20032-2LF
SMALL SCREW IN; 1.83" BODY AT THREAD; FITS PINTO TAPER	K772	20034	20034LF
SAME AS 20034 EXCEPT .200" LONGER STUD USED TO RAISE THE ROLL CENTER	N/A	20034-1	•

LOWER BALL JOINTS APPLICATION	INT#*	STANDARD	LOW FRICT.
SMALL SCREW IN; 1.83" BODY AT THREAD; FITS PINTO TAPER	K772	20034	20034LF
SAME BODY AS 20034 EXCEPT LARGER STUD	K719	20035	•
LARGE SCREW IN; 2.00" BODY AT THREAD	K727	20036	20036LF
POPULAR RACING DESIGN; PRESS-IN DIMENSION: 2.180"	K6141	20038	20038LF
POPULAR RACING DESIGN WITH LONGER STUD TO RAISE ROLL CENTER; PRESS-IN DIMENSION: 1.980"	K6117	20038-1	20038-1LF

*INTERCHANGE NUMBER USED BY OTHER MANUFACTURERS.

BALL JOINT SLEEVES



LARGE THREADED WITH FLANGE FOR 20036
20041



LARGE THREADED FOR 20036
20042



SMALL THREADED FOR 20034, 20035
20043



SMOOTH FOR 20039
20044



SMOOTH FOR 20038
20045



SMOOTH FOR 20038-1
20046

DESCRIPTION	I.D.	O.D.	HEIGHT	WEIGHT	PART #
LARGE THREADED FOR 20036 WITH FLANGE	2.000"	2.30" / 2.840"	1.00"	.45LB	20041
LARGE THREADED FOR 20036	2.005"	2.375"	1.00"	.35LB	20042
SMALL THREADED FOR 20034, 20035	1.830"	2.250"	1.00"	.35LB	20043
SMOOTH FOR 20039	2.090"	2.375"	1.00"	.25LB	20044
SMOOTH FOR 20038	2.180"	2.5"	1.00"	.30LB	20045
SMOOTH FOR 20038-1	1.980"	2.185"	1.00"	.20LB	20046

CONTROL ARM BUSHINGS

LIGHTWEIGHT LOWER ARM BUSHINGS

AFCO's precision-machined steel replacement bushings offer dramatic reductions in friction when compared to rubber or urethane-style bushings. By nearly eliminating drag on suspension movement, your shock and springs will work more effectively to keep your tires stuck to the track.



- Near zero-drag bushings!
- Inner sleeve allows bolt to be tightened without crushing or binding.
- Dimensions allow direct replacement of the standard bushing.
- Dramatically frees up front suspension.

LIGHTWEIGHT LOWER ARM BUSHING DIMENSIONS

PART #	DIAMETER	LENGTH	LBS.
20069LW	1.40"	2.94"	0.625
20075LW	1.40"	2.39"	0.625
20076LW	1.65"	2.39"	0.625
20076LW-1 (9/16 I.D.)	1.65"	2.39"	0.625
20077LW	1.90"	2.39"	0.750
20077LW-1 (9/16 I.D.)	1.90"	2.39"	0.750

SERVICE PARTS: FOR NYLON SLEEVE, ADD -B TO PART NUMBER, (20075LW-B). FOR INNER SLEEVE, ADD -C TO PART NUMBER, (20075LW-C).

STANDARD STEEL ARM BUSHINGS



- Near zero-drag bushings!
- Dimensions allow direct replacement of the standard bushing.
- Dramatically frees up front suspension.

STANDARD LOWER ARM BUSHING DIMENSIONS

PART #	DIAMETER	LENGTH	LBS.
20069	1.40"	2.94"	1.250
20075	1.40"	2.39"	1.250
20076	1.65"	2.39"	1.250
20077	1.90"	2.39"	1.750

STANDARD UPPER ARM BUSHING DIMENSIONS

PART #	DIAMETER	LENGTH
20078	1.27"	1.50"
20079	1.53"	1.84"
20098	1.39"	1.88"
20099	1.31"	1.79"

NOTE: DUE TO PRODUCTION TOLERANCE VARIANCE IN ORIGINAL EQUIPMENT PARTS, STEEL BUSHINGS NEED TO BE TACK-WELDED INTO THE CONTROL ARM.

GENERAL APPLICATION GUIDES

LOWER ARM BUSHINGS

DESCRIPTION	STANDARD		LIGHTWEIGHT	
	FRONT	REAR	FRONT	REAR
'78-'88 MONTE CARLO/MALIBU/CHEVELLE/REGAL	20069	20076	20069LW*	20076LW*
'75-'77 MONTE CARLO/MALIBU/CHEVELLE/REGAL	20076	20077	20076LW-1	20077LW-1
'73-'74 MONTE CARLO/MALIBU/CHEVELLE/REGAL	20075	20077	20075LW	20077LW-1
'67-'72 RB MONTE CARLO/MALIBU/CHEVELLE/REGAL	20075	20076	20075LW	20076LW
'78-'87 CUTLASS/GRAND PRIX	20069	20076	20069LW*	20076LW*
'73-'77 CUTLASS/GRAND PRIX	20076	20077	20076LW-1	20077LW-1
'69-'72 CUTLASS/GRAND PRIX	20075	20075	20075LW	20075LW**
'71-'96 CAPRICE/IMPALA	20076	20077	20076LW-1	20077LW-1
'73-'79 CAMARO, FIREBIRD-T/A	20076	20077	20076LW-1	20077LW-1
'67-'72 CAMARO, FIREBIRD-T/A	20075	20076	20075LW	20076LW
'75-'79 NOVA	20076	20077	20076LW-1	20077LW-1
'68-'74 NOVA	20075	20076	20075LW	20076LW

* LOWER A-ARM MOUNTS MUST BE DRILLED 1/2". USE 1/2" MOUNTING BOLT.

** SOME MODIFICATION MAY BE NECESSARY.

EACH SOLD SEPARATELY.

UPPER ARM BUSHINGS

DESCRIPTION	STANDARD	STANDARD
	FRONT	REAR
'78-'88 MONTE CARLO	20079	20079
'74-'77 MONTE CARLO*	20098	20099
1973 MONTE CARLO*	20099	20099
'67-'72 MONTE CARLO*	20078	20078
'80-'96 CAPRICE/IMPALA	20098	20098
'74-'79 CAPRICE/IMPALA	20098	20099
'71-'73 CAPRICE/IMPALA	20099	20099
'71-'79 CAMARO	20098	20099
'67-'69 CAMARO	20078	20078
'75-'79 FIREBIRD-T/A	20098	20099
'70-'74 FIREBIRD-T/A	20099	20099
'67-'69 FIREBIRD-T/A	20078	20078
'75-'79 NOVA	20098	20099
'68-'74 NOVA	20078	20078

* ALSO FITS MALIBU, CHEVELLE, REGAL, CUTLASS, & GRAND PRIX.

REAR CONTROL ARM BUSHING WITH SPHERICAL BUSHING

These steel rear control arm bushings have spherical bearings in them just like a rod end, which frees up suspension movements and eliminates binding. Fits '73-'88 GM mid-size rear control arms. Sold individually.



DESCRIPTION	PART #
REAR CONTROL ARM BUSHINGS (1 PCS)	20095

OFFSET REAR CONTROL ARM BUSHINGS

These polyurethane bushings have the center hole offset 1/4" to allow you to compensate for wheel or pinion angle issues. Fits '65-'88 GM mid-size rear control arms. Sold per pair.



DESCRIPTION	PART #
OFFSET REAR CONTROL ARM BUSHINGS (2 PCS)	20090

LOW FRICTION BALL JOINT & BUSHING KITS

Each kit contains: 4 high performance low friction ball joints and 8 lightweight, friction-reducing control arm bushings.

- **Only 2 ft. lbs. of resistance and less bind = lower lap times.**
- Assembled kits for easy ordering.
- No modifications necessary - simply choose your application and go.
- Reduced suspension "stiction".
- Increases ability to transfer weight.
- Precision machining promotes front end alignment during usage (unlike O.E. rubber bushings).
- Kits contain lightweight lower bushings (nylon inserts for reduced weight and less friction).



APPLICATION

APPLICATION	PART #
'66-'72 CHEVELLE / MONTE CARLO, CUTLASS / 442, SPECIAL / SKYLARK/GS, LEMANS / GTO / '67-'69 CAMARO, FIREBIRD	200-1001
'68-'74 CHEVY II / NOVA / '68-'74 APOLLO, OMEGA & VENTURA	200-1001
'78-'88 CHEVELLE / MALIBU / MONTE CARLO / '78-'87 CUTLASS, LEMANS / GRAN PRIX, REGAL / SPECIAL, CUTLASS	200-1002
'70-'72 CAMARO, FIREBIRD / '73 CHEVELLE / MONTE CARLO WITH 1.4" OD FRONT LOWER BUSHING	200-1003
'75-'79 CAMARO / NOVA, APOLLO, OMEGA / PHOENIX, VENTURA / '74-'79 FIREBIRD / '75-'77 CHEVELLE / MONTE CARLO, REGAL / SPECIAL, CUTLASS / 442, LEMANS / GTO	200-1004
'82-'92 CAMARO, FIREBIRD (INCLUDES 2 BALL JOINTS & 4 BUSHINGS)	200-1006

TAPER REAMERS

- Manufactured from superior-quality, high-speed tool steel.
- Six flute spiral design allows smooth boring operation & minimizes tool wear.
- Two designs to cover most popular racing applications.

DESCRIPTION	APPLICATION	PART #
1-1/2" TAPER (PER FOOT)	MOST TIE ROD, SHOCK EYES & 20031, 33, 34, 35, 36 BALL JOINTS	80770
2" TAPER (PER FOOT)	20032, 32-1,32-2, 38, 38-1, 39 BALL JOINTS	80771

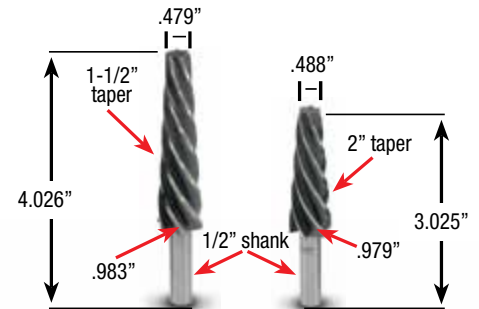

Ron Vnuk

LEAF SPRINGS

REINFORCED FRONT SEGMENT LEAF SPRINGS

The new AFCO reinforced front segment springs have proven to provide considerable increases to forward bite when used on race cars equipped with conventional type leaf springs.

New secondary leaf design means:

- Quicker throttle response.
- Improved forward bite.
- Improved durability of leaf spring.
- Reduces wheelbase variations during braking and acceleration to improve overall handling consistency.
- 10 - 15% stiffer front segment.



DESCRIPTION	CAR WT.	ACT. ARCH	NOM. RATE	PART #
CAMARO TYPE	25-3000#	6-3/8"	176	20228RF
CAMARO TYPE	30-3400#	6-3/8"	205	20228HDRF
CHRYSLER TYPE	28-3200#	6-5/8"	166	20231HDRF

LEAF SPRING DIMENSIONS CHART

DESCRIPTION	WIDTH	FRONT SEGMENT	EYE TO EYE LENGTH	EYE ID FRONT	EYE ID REAR
CAMARO TYPE	2-1/2"	24-3/4"	54"	2"	1-5/8"
CHRYSLER TYPE	2-1/2"	20-1/2"	52-7/8"	1-1/2"	1"

To accurately check for arch measurement, lay spring on side and pull a straight line from center of front eye to center of rear eye. Measure from line to top leaf at the locating pin.



AFCO MULTILEAF SPRINGS

Racers using multileaf springs realize the importance of accurate arch, load capacity, and durability. AFCO Leaf Springs are the highest quality racing springs available and give you features not available in any other leaf spring.

- Our chrome-vanadium alloy spring steel material is superior to others and provides consistent rates over a longer life span.
- Teflon rub blocks between leaves reduces friction and maintains consistency of rate.
- Tapered leaves reduces stress by 30-40% and prevents loss of arch.
- Shot-peened after arching to reduce tensile stress provides 3 - 5 times more service life to the spring.
- Chrysler or Camaro style.
- Front bushing included.

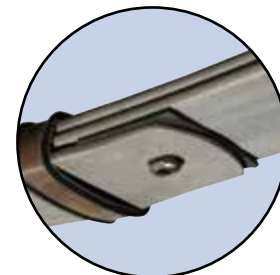

REFERENCE ARCH	CAR WT.	ACT. ARCH	NOM. RATE	PART #
CHRYSLER TYPE - 5" ARCH	23-2800#	6-5/8"	142	20231
CHRYSLER TYPE - 5" ARCH	26-3000#	6-5/8"	152	20231MHD
CHRYSLER TYPE - 5" ARCH	28-3200#	6-5/8"	166	20231HD
CHRYSLER TYPE - 5" ARCH	31-3500#	6-5/8"	194	20231XHD

DESCRIPTION	CAR WT.	ACT. ARCH	NOM. RATE	PART #
CAMARO TYPE	23-2600#	6-3/8"	153	20228LW
CAMARO TYPE	25-3000#	6-3/8"	176	20228
CAMARO TYPE	30-3400#	6-3/8"	205	20228HD
CAMARO TYPE	30-3400#	6-3/8"	238	20228XHD

LEAF SPRING PIVOT BUSHING

- Allows front eye to rotate and twist in order to react to spring movement.
- Replaces rubber bushing and gets rid of bind.
- Promotes more consistent handling.
- Chrysler-type only.
- 1-1/2" OD.



DESCRIPTION	PART #
PIVOT KIT	20229P

LEAF SPRING SLIDER

- Frees up car during suspension movement.
- Pre-drilled holes for bolt-on applications.
- Roller bearing design prevents binding.
- Use in place of shackles.
- Designed for Chrysler type or GM springs.



For 2-1/2" wide leaf.

DESCRIPTION	PART #
LEAF SPRING SLIDER (CHRYSLER)	20236S
LEAF SPRING SLIDER (CAMARO)	200036

WELD-ON LEAF SPRING PADS

Works with all 2-1/2" wide leaf springs.



DESCRIPTION	PART #
PAD (1) - FOR 3" AXLE TUBE	20232

NYLON FRONT EYE BUSHING

- Inner sleeve protects bushing and mount hardware for longer parts life.
- Fits Chrysler-type spring.
- 3-piece design allows front eye to rotate as spring moves.



DESCRIPTION	PART #
BUSHING ASSEMBLY (1)	20229N

UNIVERSAL FRONT SPRING MOUNT

- Universal design for new chassis or updating older chassis to leaf spring suspension.
- Fits Chrysler type leafs.



DESCRIPTION	PART #
MOUNT	50200

SHACKLE PLATES

- Steel or aluminum.
- 2 required per-spring.
- Fits late models and modifieds.
- 5/16" anodized aluminum or 1/4" plated steel.



DESCRIPTION	PART #
5/16" ANODIZED ALUM. (1)	20235
5/16" PLATED PLATE STEEL (1)	20281

LOWER SPRING PLATES

- Fits 2-1/2" leaf springs.
- Heavy duty steel construction.
- Can be used with coil-over shocks.



DESCRIPTION	PART #
LEAF SPRING PLATE LH (STEEL)	20249
LEAF SPRING PLATE RH (STEEL)	20250

SPRING SHACKLES

Standard part as used on most leaf spring cars.



DESCRIPTION	PART #
CAMARO - '70-'75	20236-1
CAMARO - '76-'81	20236-2

SHACKLE BOLT KIT

Eliminates need for rubber bushings in Chrysler rear spring eye. Prevents binding and eases leaf spring maintenance. 1" OD bushing.



DESCRIPTION	PART #
BOLT KIT	20235-2
SHOULDER BOLT	20235-3
BUSHING	20235-4

ALUMINUM LOWERING BLOCKS



DESCRIPTION	PART #
1/2" BLOCK	20244
3/4" BLOCK	20245
1" BLOCK	20246
1-1/2" BLOCK	20247
2" BLOCK	20248
3" BLOCK	20243
ADJUSTABLE BLOCK 1-1/2" TALL	20270

U-BOLTS

- 4" threads.
- Fits all 3" axle tubes.
- Plated for added protection.
- Includes tall nuts for added safety.



DESCRIPTION	PART #
8"	20238
9-1/2"	20238-9

AFCO STEERING

OEM REPLACEMENT STEERING

DESCRIPTION	CHEVELLE '68-'72	CAMARO '70-'81	MONTE CARLO '78-'88	GM MID SIZE '78-'83
1) CENTER LINK PS	30274	30272	30270	30270
2) TIE ROD - OUTER	•	30210*	30220	30220
3) ADJUSTER SLEEVE	•	30233	30230	30230
4) TIE ROD - INNER LH	•	30208*	30221	30221
4) TIE ROD - INNER RH	•	30209	30221	30221
5) IDLER ARM	30260	30262	30261	30261

* LISTED TIE ROD ENDS WILL WORK ON '70-'74 MODELS WHEN USED AS AN INNER/OUTER ASSEMBLY.

AFCO CENTER LINK

Relocates the inner tie rod end to shorten both tie rod assemblies, which improves steering geometry by reducing the excessive toe out that is common to GM metric chassis during normal suspension travel (bump steer).



IMPROVE YOUR GM METRIC SUSPENSION GEOMETRY WITH AN AFCO CENTER LINK!

DESCRIPTION	PART #
CENTER LINK - FITS MONTE CARLO '78-'88 & GM MID SIZE '78-'83	30271*
<i>*FITS '78-'88 METRIC CARS ONLY. NOTE: TIE ROD ENDS & ADJUSTMENT SLEEVE MUST BE SHORTENED WHEN USING THIS CENTER LINK.</i>	

INNER TIE ROD ENDS

- 5/8" threaded.
- Used in AFCO tie rod assembly.
- Most popular tie rod end; fits most rack & pinion cars.
- Same taper as 30201.

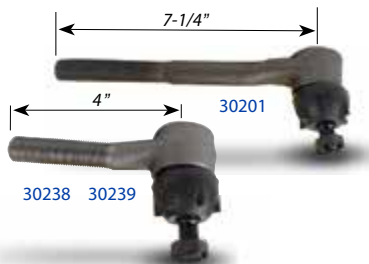

APPLICATION	PART#
7-1/4" LENGTH 5/8" RH THREADED	30201
4" LENGTH 5/8" RH THREADED	30238
4" LENGTH 5/8" LH THREADED	30239

GM TIE ROD ENDS

- 3/4" threaded.
- High-quality.
- Replaces ES150.



APPLICATION	PART#
LH THREADS	30211
RH THREADS	30212

ROD ENDS

STANDARD

Excellent for use as a medium-duty suspension rod end.



BORE	SHANK	TYPE	RH	LH
3/8"	3/8"	MALE	10460	10461
3/8"	3/8"	FEM	10462	•
1/2"	1/2"	MALE	10440	10441
1/2"	1/2"	FEM	10442	10443
5/8"	5/8"	MALE	10430	10431
5/8"	5/8"	FEM	•	10433
3/4"	3/4"	MALE	10420	10421
3/4"	3/4"	FEM	10422	10423

AIRCRAFT QUALITY

- Designed for high-stress usage.
- Ideal for panhard bar or drag components.



BORE	SHANK	TYPE	RH	LH
1/2"	1/2"	MALE	10444	10445
5/8"	5/8"	MALE	10434	10435
3/4"	3/4"	MALE	10424	10425

STEERING

- Extra-heavy duty and won't loosen up.
- 5/8" bore and 5/8" shank.
- 3/4" sized body.
- Made for steering use.



DESCRIPTION	PART #
LH THREAD	10401
RH THREAD	10402

OVERSIZED

- .007" oversized to slide on 3/4" steering shaft.



DESCRIPTION	PART #
STEEL	10400

HD SHANK

- Used under potentially rough conditions.
- Bore size is one size smaller than shank and body.



BORE	SHANK	TYPE	RH	LH
1/2"	5/8"	MALE	10448	10449
5/8"	3/4"	MALE	10438	10439

CHROME MOLY

- Chrome moly body — 2 piece design.
- Designed for heavy duty application.



BORE	SHANK	TYPE	RH	LH
5/8"	5/8"	MALE	10456	10457
3/4"	3/4"	MALE	10458	10459

SOLID ROD ENDS



BORE	THREAD	PART #
3/4"	3/4" - RH	10820
1/2"	3/4" - RH	10821

SOLID ROD ENDS SOLD SEPARATELY.

STEEL JAM NUTS



SIZE	THICK	RH	LH
1/4" - 28	7/32"	10136	•
3/8" - 24	1/4"	10138	10139
1/2" - 20	5/16"	10144	10145
5/8" - 18	3/8"	10142	10143
5/8" - 18	NYLOCK	10142N	•
3/4" - 16	7/16"	10140	10141
3/4" - 16	NYLOCK	10140N	•

ROD END APPLICATION CHART

DESIGN	STANDARD 2 PIECE	CHROME MOLY 2 PIECE	AIRCRAFT 3 PIECE	HEAVY DUTY 3 PIECE
BALL	CASE HARDENED STEEL HARD CHROME PLATED	52100 STEEL HARD CHROME PLATED	52100 STEEL HARD CHROME PLATED	52100 STEEL HARD CHROME PLATED
RACE	N/A	N/A	HEAT TREATED STEEL ALLOY ZINC PLATED	HEAT TREATED STEEL ALLOY
BODY	LOW CARBON STEEL CHROMATE TREATED	4130 CHROME MOLY	HEAT TREATED STEEL ALLOY CAD OR ZINC PLATED	LOW CARBON STEEL CAD OR ZINC PLATED
MAX STATIC	(5/8") 11,169#	(5/8") 18,000#	(5/8") 17,950#	(5/8") 16,500#
RADIAL LOAD	(3/4") 16,338#	(3/4") 25,000#	(3/4") 28,000#	(3/4") 22,800#
APPLICATIONS	STANDARD SUSPENSION	ROUGH CONDITIONS STEERING/OFF-ROAD	HIGH STRESS (PANHARD BAR) DRAG CAR SUSPENSION	ROUGH CONDITIONS STEERING/OFF-ROAD

STEERING ACCESSORIES

PINTO/MUSTANG II SPINDLES

For use on modifieds, sportsman cars, drag cars, and street cars.

- NEW forged spindles - not reworked O.E.M.
- Brake brackets sold separately.



PINTO/MUSTANG II SPINDLES	PART #
PINTO/MUSTANG II SPINDLE - PAIR	AD30436
PINTO/MUSTANG II SPINDLE NUT	9851-8545

CALIPER BRACKETS

Adapts stock '74-'80 Pinto / Mustang II spindle to small GM caliper with '75-'80 Ford Granada-type rotor.



BRACKET DESCRIPTION	THREAD	THICKNESS	PART #
GM METRIC LH-PINTO SPINDLE, GRANADA ROTOR	7/16" FINE	1/4"	40121PL
GM METRIC RH-PINTO SPINDLE, GRANADA ROTOR	7/16" FINE	1/4"	40121PR

ADAPTER BOLT

- Adapter allows inner tie rod end to be replaced with rod end on rack & pinion.
- Complete with nuts and bump spacer.
- Not for stock-style spindle use.
- 1-1/2" taper per foot.



DESCRIPTION	PART #
BOLT KIT (1PC)	10270

PUSH-BUTTON QUICK RELEASE HUB

This hub features a spring-loaded button-style release. Unit fits 3/4" shaft and a standard three bolt steering wheel pattern.

- 5/16" coarse thread.
- Aluminum .55 lbs.



DESCRIPTION	PART #
PUSH BUTTON ECONOMY QR HUB	30373
REPLACEMENT COUPLER	30373B

U-JOINTS & COUPLERS

The splined U-joints feature a set screw & lock-nut. These are the best U-joints you can buy.

- Greased needle bearing with Teflon seal.
- 1-1/8" O.D. x 3-3/4" length.
- Broached spline for better fit.
- Heat-treated forgings.
- Forged 1045 steel.



U-JOINT BORE	DESCRIPTION	PART #
3/4"	SMOOTH BOTH ENDS	30303
3/4" - 48	SWEET R & P / APPLETON MANUAL	30304
3/4" - 36	GM STANDARD, PINTO P.S.	30305
3/4" - 20	FITS 37304 STEERING COLUMN & WOODWARD RACK	30305B
13/16" - 36	EARLY GM (THRU 76) POWER STEERING	30306
9/16" - 26	PINTO/MUSTANG II MANUAL	30307
3/4" - 30	LATE (77 & UP) GM P.S. (APPLETON P.S.)	30308
5/8" - 36	VEGA MANUAL	30309

COUPLER BORE	DESCRIPTION	PART #
3/4" - 36	GM STANDARD, PINTO P.S.	30315
3/4" - 20	37304 COLUMN	30316

ERIC KENWARD

2016 NMCA Xtreme Street Champion Eric Kenward relies on "AFCO by Menscer" shocks for performance. "I've known and worked with the people at AFCO for a long time. Menscer Motorsports builds some of the fastest shocks on the market. This partnership has been very beneficial to my racing program. We race and win as a team!"



AFCO ACCESSORIES

GEAR REDUCTION MINI STARTER

This unit mounts on the Chevy block in either the 153 or 168 tooth location and features 1.4kw of power to start any racing engine. Each starter comes with bolts, shim kit, instructions, and jumper wire.

- **6 month replacement guarantee.**
- Chevy block mount style.
- Lightweight — only 11 lbs.
- All-new components.
- Easily indexable without requiring disassembly.
- Mounting block is indexable to provide clearance with wide oil pans.



INDEXABLE
(TO ELIMINATE
INTERFERENCE)
WITHOUT REQUIRING
DISASSEMBLY

DESCRIPTION	PART #
STARTER 1.4KW	64200

THROTTLE ROD & KITS

- 1/4" plated steel rod.
 - Kit includes: carb bushings, rod ends, jam nuts, & rod.
- NOTE: Extra-long thread allows more adjustment.



COMPONENTS	PART#
1/4" RH THREADED THROTTLE ROD ENDS MALE	10480S
1/4" RH THREADED THROTTLE ROD ENDS FEMALE	10482S
BUSHING KIT WITH RH THREADED MALE ROD END	10170
BUSHING KIT WITH RH THREADED FEMALE ROD END	10171
CARBURETOR BUSHINGS (PAIR)	10174

LENGTH	ASSY RANGE	KIT	ROD ONLY
18"	19-1/8"-19-7/8"	10175-18	10176-18
21"	22-1/8"-22-7/8"	10175-21	10176-21
24"	25-1/8"-25-7/8"	10175-24	10176-24

WELD-IN BATTERY BOX

- Lightweight steel construction.
- 9-1/2" or 11" size.
- 5/16" side bolts pivot to accommodate different battery sizes.



DESCRIPTION	PART #
BATTERY BOX (9-1/2")	50302
BATTERY BOX (11")	50301

BOLT-IN BATTERY BOX

- Holds 10-3/4" x 7" battery.
- Lightweight steel.
- Includes 3/8" bolts.



DESCRIPTION	PART #
BOLT-IN BATTERY BOX	50303

HOOD PIN KITS

Steel kits include 1-torsion (flip) pin or hair pin, 1-scuff plate, 2-jam nuts and 1-stud.



DESCRIPTION	PART #
STEEL KIT W/ 3/16" CLIP	10151

FUEL SHUT-OFF VALVE

Install in fuel line so fuel flow can be shut off. This valve is alcohol compatible.



DESCRIPTION	PART #
VALVE (1/2" FEMALE NPT)	84040

LUDWIG CLAMPS

- Secures hinged lids, panels, etc.
- Held in place by a single rivet.



DESCRIPTION	PART #
LUDWIG CLAMPS 4 PK	50401
LUDWIG CLAMPS 100	50403

HOOD PIN COMPONENTS



DESCRIPTION	PART #
FLIP CLIP - 3/16"	10183
HAIR PIN CLIP - 5/32"	10185
SCUFF PLATE	10188
THREADED HOOD PIN BOSS	10190X-1

AFCO BRAKES

CALIPERS

FEATURES & BENEFITS OF AFCO FORGED ALUMINUM CALIPERS

- Stiffest caliper on the market - Still at 4.8 lbs.
- Less brake heat - Less time on the brakes and no fade.
- Extra wheel clearance - For left rear inner bead locks.
- Universal mounting - One caliper can fit the entire car.
- Mount uses standard 3-1/2" & 5-1/4" bolt pattern spacing.
- Forged 6061 aluminum construction.
- 1/8" NPT inlet port.

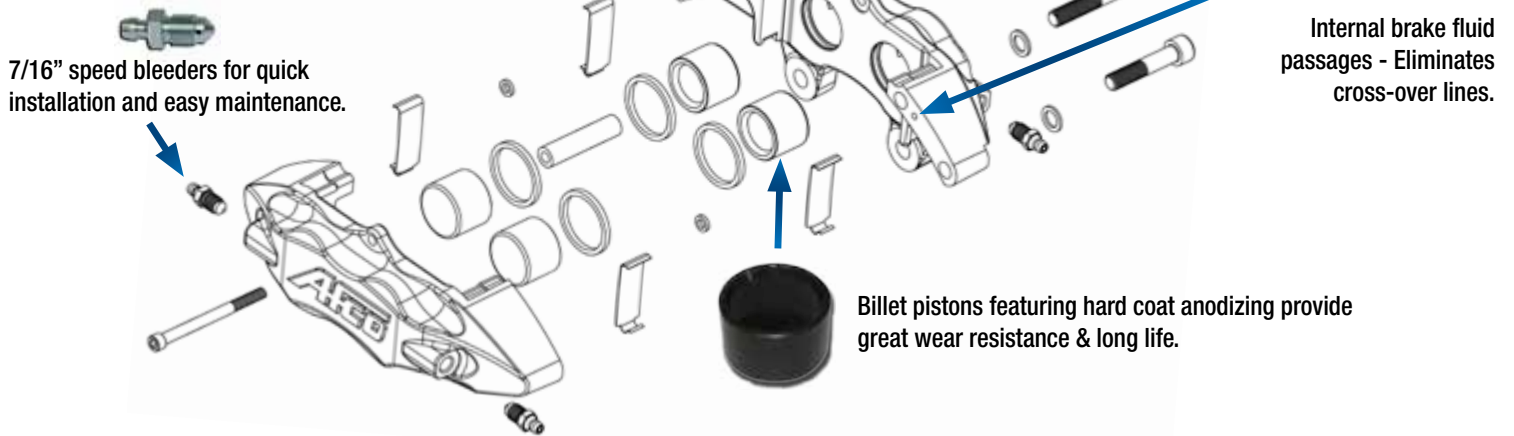

LYLE BARNETT



F33 CALIPERS

F33 FORGED ALUMINUM CALIPER

- Forged pistons feature hard coat anodizing for wear resistance and long life.
- Mounting holes on 5-1/4" center.
- Internal brake fluid passages eliminate cross-over lines.
- Extreme duty steel bridge bolts increase stiffness by 30% vs. billet caliper model.
- 7/16" speed bleeders for quick installation and easy maintenance.



5.25" MOUNTING LUGS

DESCRIPTION	ROTOR WIDTH	PISTON DIA.	PART #
F33 FORGED CALIPER	.375"	1.75"	6630100

F33 FORGED ALUMINUM CALIPER ACCESSORIES			
DESCRIPTION			PART #
PISTON FOR 1.75" FORGED CALIPER F33			6690294
O-RING KIT FOR 1.75" FORGED CALIPER F33			6690256
RUBBER BLEEDER CAP - 4 PACK			6691318

F11 CALIPERS

F11 FORGED ALUMINUM CALIPER

- Forged pistons feature hard coat anodizing for wear resistance and long life.
- Extra wheel clearance.
- Mounting holes available in 3-1/4" and 3-3/4".
- Dual internal brake fluid passages eliminate cross-over lines.
- Extreme duty steel bridge bolts increase stiffness by 40% vs. the competition.
- 7/16" speed bleeders for quick installation and easy maintenance.



3.25" OR 3.75" MOUNTING LUGS

DESCRIPTION	ROTOR WIDTH	PISTON DIA.	BOLT PATTERN	PART #
F11 FORGED CALIPER	.375"	1.75"	3.25"	6630410
F11 FORGED CALIPER	.375"	1.75"	3.75"	6630420

F11 FORGED ALUMINUM CALIPER ACCESSORIES			
DESCRIPTION			PART #
PISTON FOR 1.75" FORGED CALIPER F11			6690294
O-RING KIT FOR 1.75" FORGED CALIPER F11			6690256
RUBBER BLEEDER CAP - 4 PACK			6691318

METRIC CALIPERS

SMALL GM CALIPER

- Optional piston sizes available to increase range of brake bias adjustment for better brake performance and more brake system tuning.
- Quality control checked & pressure tested.
- Oversized: 20% more force.
- Stock-appearing.

DESCRIPTION	PART #
OVERSIZE GM METRIC CALIPER-RIGHT SIDE	7241-9001
OVERSIZE GM METRIC CALIPER-LEFT SIDE	7241-9002
STOCK GM METRIC CALIPER-RIGHT SIDE	6635003
STOCK GM METRIC CALIPER-LEFT SIDE	6635004

VEHICLE APPLICATIONS: '78-'87 MONTE CARLO, GRAND PRIX, REGAL, CUTLASS, MALIBU.



5.5" MOUNTING LUGS

METRIC CALIPERS

ALUMINUM CALIPER

- The **LIGHTEST** Metric Caliper on the market!
- 20% stiffer than cast! Forged construction with extra large crossbolts gives less flex, better pedal feel, less brake fade, and less pad taper than the competition.
- Comes with 2 one-piece bleeders - fits left or right side of chassis.
- 2-1/2" bore piston.
- 1/8" NPT inlet fluid port.
- Stainless guide plates.
- NEW low drag seals.

**Reduces Unsprung Weight
By 15 lbs. Over Stock!**

DESCRIPTION	PART #
2.5" BORE - ALUMINUM METRIC CALIPER	6630510
2" BORE - ALUMINUM METRIC CALIPER (OLD CAST STYLE)	6630310
REBUILD KIT, 2" METRIC ALUMINUM	6690310
2.5" F44 SEAL	6690334
2" SEAL	55000018905

NEW!



5.5" MOUNTING LUGS

METRIC CALIPERS

LIGHTWEIGHT CAST IRON CALIPER

AFCO took the stock caliper and removed material where it was not needed while maintaining stiffness.

- Track tested and proven to have less flex, better pedal feel, less brake fade, and less pad taper than the competition.
- Quality control checked and pressure tested.
- 2-3/4" bore for maximum force.
- Speed bleeder included.
- Fits left or right side of chassis.
- M10 X 1.5 inlet port.

**Makes Your Car 8 lbs.
Lighter Than Stock!**

DESCRIPTION	PART #
2.75" BORE - LIGHTWEIGHT CAST IRON CALIPER	6630312
REPAIR KIT	6690312



5.5" MOUNTING LUGS

AFCO BRAKES

BRAKE PADS

AFCO proudly offers its line of racing and high performance brake pads. These brake pads have gone through extensive development and testing in the toughest racing environments. Our racing brake pads are derived from the latest materials in friction products and utilize the latest technologies in brake pad manufacturing.

- Improved stopping power.
- High torque with excellent control qualities.
- Exceptional high temperature performance.
- User-friendly/easy break-in.
- Exceptional pad and rotor wear.
- Available in five compounds (32, C1, 33, C2 and 34) to fit popular caliper styles.

MADE IN THE U.S.A.

F33 & F11 DRAG RACING BRAKE PADS

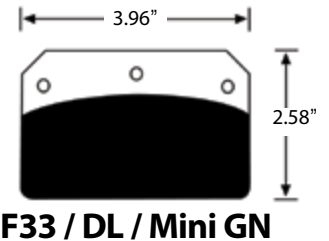
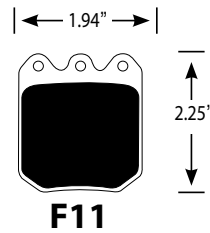

DESCRIPTION	PART #
F33 / DL / MINI GN	1251-3000
F11 C1 STEEL ROTOR	6654011

METRIC GM BRAKE PADS

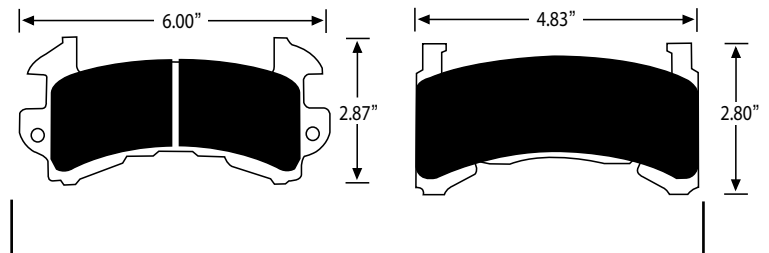

DESCRIPTION	PART #
GM METRIC D154	1251-1154

Metric GM (pair)



AFCO BRAKES

MASTER CYLINDERS

INTEGRAL RESERVOIR MASTER CYLINDER

The AFCO engineering team started with a clean sheet when designing our master cylinders. AFCO's master cylinders offer the same great performance that customers have come to expect from AFCO. With a one-piece design that incorporates a high-capacity reservoir and precisely machined/polished cylinder bore, the piece makes efficient use of space and materials.

- External return spring maintains positive pedal feel and helps prolong pad life by ensuring quick reaction to released pedal force.
- Precise-fitting lid held firmly in place by heavy gauge retainer.
- Slim design rubber boot allows easy installation into most pedal assemblies.
- Aluminum bore with hard anodized pistons.
- Unique, built-in minimum and maximum fill tabs are easy to read and make quick work of checking fluid even in dark pit areas.
- Common dual-mounting bolt patterns for most racing applications.
- Models come in 3/4", 7/8", and 1" bores.
- Designed for standard 1/8" NPT fittings for easy replacement.



DESCRIPTION	PART #
3/4" BORE INTEGRAL MASTER CYLINDER	6620010
7/8" BORE INTEGRAL MASTER CYLINDER	6620011
1" BORE INTEGRAL MASTER CYLINDER	6620012



INTEGRAL MASTER CYLINDER SERVICE PARTS & REBUILD KITS

MASTER CYLINDER PARTS	PART #
STRAIGHT FITTING (1/8"NP X 3/16"IF)	7010-0026
90° FITTING (1/8"NP X 3/16"IF)	7010-0027
MASTER CYL. KIT (INCLUDES LID, GASKET, WIRE)	6690048
MASTER CYL. KIT (INCLUDES PUSH ROD, SPRING, BOOT)	6690049

MASTER CYLINDER PARTS	PART #
REBUILD KIT - 3/4" NEW AFCO M/C	6690110*
REBUILD KIT - 7/8" NEW AFCO M/C	6690111*
REBUILD KIT - 1" NEW AFCO M/C	6690112*

*KITS FOR AFCO MASTER CYLINDER MANUFACTURED AFTER JAN 2013.

REMOTE RESERVOIR MASTER CYLINDER KIT

- External return spring maintains positive pedal feel and helps prolong pad life by ensuring quick reaction to released pedal force.
- Slim design rubber boot allows easy installation into most pedal assemblies.
- Common dual-mounting bolt patterns for most racing applications.
- Designed for standard 1/8" fittings for easy replacement.
- Aluminum bore with hard anodized pistons.
- Models come in 3/4", 7/8", and 1" bores.

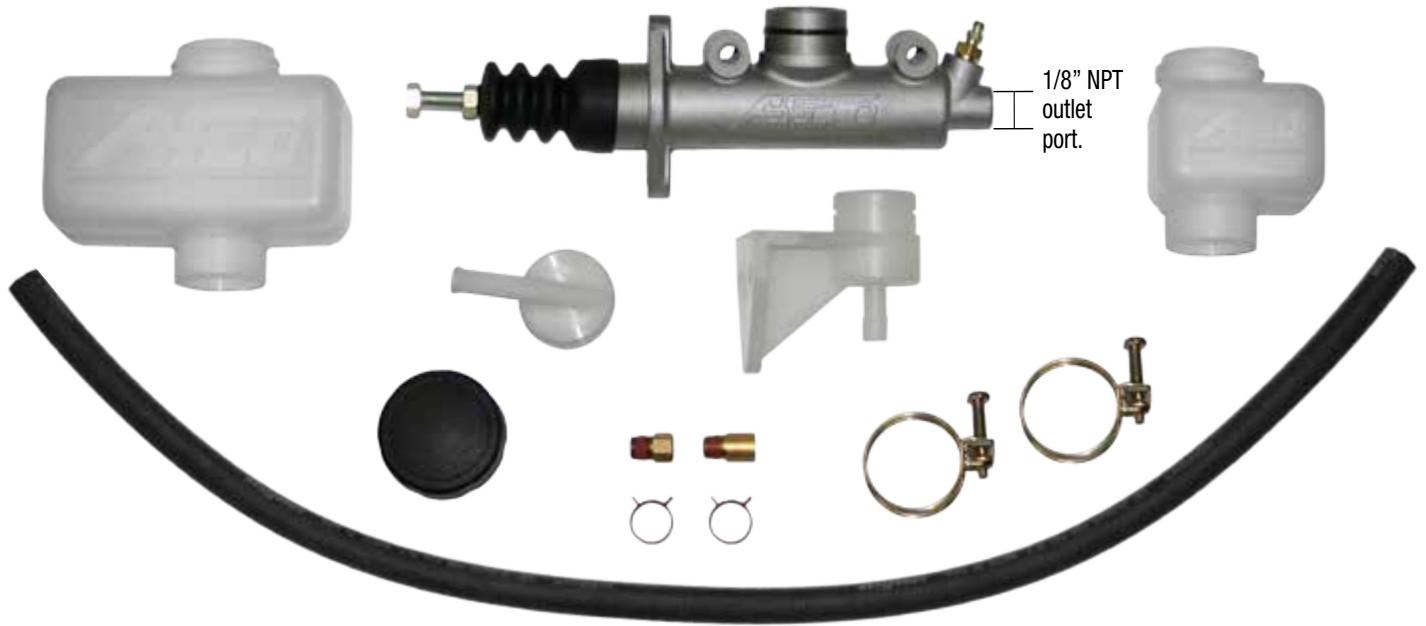

REMOTE RESERVOIR MASTER CYLINDERS

DESCRIPTION	PART #
3/4" BORE REMOTE RESERVOIR MASTER CYLINDER	6620110
7/8" BORE REMOTE RESERVOIR MASTER CYLINDER	6620111
1" BORE REMOTE RESERVOIR MASTER CYLINDER	6620112

MASTER CYLINDER REBUILD KITS

MASTER CYLINDER REBUILD KITS	PART #
REBUILD KIT - 3/4" AFCO M/C	6690110
REBUILD KIT - 7/8" AFCO M/C	6690111
REBUILD KIT - 1" AFCO M/C	6690112

TOM BAILEY

"Sick Seconds 2.0" - The two-time Drag Week Winner (2013 & 2015).



AFCO BRAKES

ROTORS

STOCK-STYLE ROTORS

GM METRIC STYLE ROTOR

Vehicle Applications: '78-'87 Monte Carlo, Grand Prix, Regal, Cutlass, Malibu

- Dual bolt patterns: 5" x 5" and 5" x 4-3/4".
- Studs included.
- 10.5" diameter x 1" thick.
- Uses 9851-8500 bearing kit.
- Pre-drilled with 4-3/4" stock pattern.
- Races installed.

DESCRIPTION	GM
7/16" FINE STUDS ON STOCK 4-3/4" PATTERN	9850-6501
5/8" COARSE STUDS ON 5" X 5" PATTERN	9850-6500
5/8" EXTRA LONG STUDS ON 5" X 5" PATTERN	6640137
HUB MASTER INSTALL KIT	9851-8550
BEARING KIT (INNER AND OUTER BEARINGS)	9851-8500
SEAL	9851-8520
DUST CAP	9851-8501
SPINDLE NUT KIT	9851-8546



FORD STYLE ROTOR

Vehicle Applications: '75-'80 Granada

- Dual bolt patterns: 5" x 5" and 5" x 4-1/2".
- Studs included.
- Reduces rotating weight.
- Fits Pinto/Must. II spindle.
- 11" diameter x .875" thick.
- Uses stock 9851-8510 bearing kit.
- Pre-drilled with 4-1/2" stock pattern.
- Uses AFCO 40121PL & 40121PR brackets for metric caliper.
- Races installed.

DESCRIPTION	FORD
1/2" FINE STUDS ON STOCK 4-1/2" PATTERN	9850-6511
5/8" COARSE STUDS ON 5" X 5" PATTERN	9850-6510
HUB MASTER INSTALL KIT	9851-8552
BEARING KIT (INNER AND OUTER BEARINGS)	9851-8510
SEAL	9851-8521
DUST CAP	9851-8502
SPINDLE NUT KIT	9851-8545



9" FORD BOLT-ON BRAKE KIT

This rear disc brake kit allows you to simply bolt disc brakes onto 9" Ford rear ends. Includes two bolt-on caliper brackets, two vented rotors, two new GM metric calipers and hardware. 9" Ford kit has 5 on 4-1/2" and 5 on 4-3/4" bolt patterns. Minor fitting may be required. For 15" and larger wheel applications only. Maximum O.D. on axle flanges is 6-1/4".

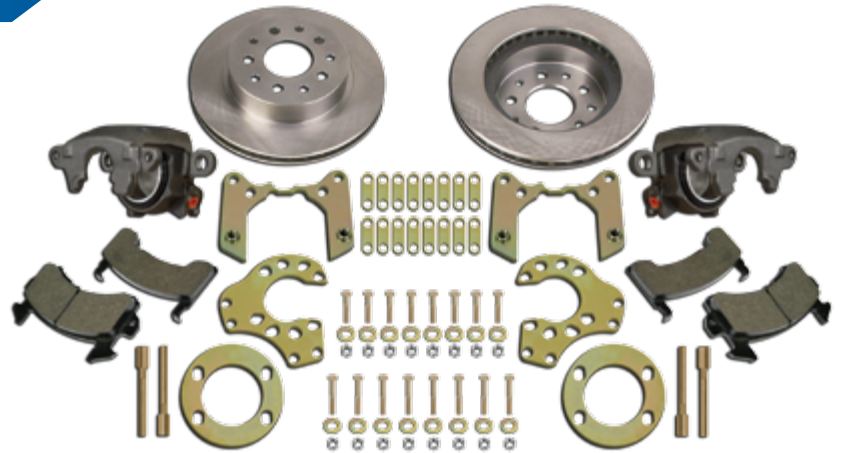

COMPLETE KITS

9" FORD BOLT-ON KIT

PART

7250-0100

MISCELLANEOUS

CALIPER BRACKETS

Adapts stock '74-'80 Pinto / Mustang II spindle to small GM caliper with '75-'80 Ford Granada-type rotor.



DESCRIPTION	THREAD	THICKNESS	PART #
SMALL GM LH-PINTO SPINDLE	7/16" FINE	1/4"	40121PL
SMALL GM RH-PINTO SPINDLE	7/16" FINE	1/4"	40121PR

CALIPER PRESSURE GAUGE & BLEEDER ADAPTERS

- Kit allows for use of the 85161 Brake Pressure Gauge with GM Metric Calipers.
- Easily determine brake pressure at the calipers.
- Accurately determine optimal settings for balance bars and proportioning valves.
- Needed to troubleshoot your brake system.



DESCRIPTION	PART #
CALIPER PRESSURE GAUGE	85161
ADAPTER KIT (FOR METRIC CALIPERS)	7010-0050

MATT WALTER

"Since switching to AFCO struts and Big Gun shocks, my Camaro has been much more controlled, consistent, and faster! I've been 2 tenths faster with more left in the combo, just by bolting on 2 AFCO struts and 2 AFCO Big Gun shocks!"



AFCO BRAKES

PEDALS

7:1 FORWARD SINGLE SWING PEDALS

- H-beam forged aluminum pedal design.
- Pedal assemblies fit many popular chassis.
- Allows for positioning of the clutch pedal to be away from the driver for better comfort.
- New snap ring gives the brake pedal more bias rod clearance and eliminates thread interference.
- Ultra high strength bias bar on brake pedal; same strength of 7/16" bias bar in the traditional 3/8" size.
- Rounded clevis design prevents bias-bar lock-up at extreme limits of travel.
- Integral bias bearing stops prevent lock-up when adjusting bias.
- Internal hex in bias bar eases bias set up.
- 7:1 Pedal ratio allows for better braking power.
- Brake pedal weight: 2.36 lbs.
- Clutch pedal weight: 1.64 lbs.
- AFCO master cylinders sold separately.



DESCRIPTION	PART #
7:1 FORWARD SINGLE SWING BRAKE PEDAL	6610003
7:1 FORWARD SINGLE SWING CLUTCH PEDAL	6610004

AFCO Master Cylinders sold separately. See Pages 60-61 for more info.

6:1 FORWARD SINGLE FLOOR PEDALS

- H-beam forged aluminum pedal design.
- Pedal assemblies fit many popular chassis.
- Allows for positioning of the clutch pedal to be away from the driver for better comfort.
- New snap ring gives the brake pedal more bias rod clearance and eliminates thread interference.
- Ultra high strength bias bar on brake pedal; same strength of 7/16" bias bar in the traditional 3/8" size.
- Rounded clevis design prevents bias-bar lock-up at extreme limits of travel.
- Integral bias bearing stops prevent lock-up when adjusting bias.
- Internal hex in bias bar eases bias set up.
- 6:1 Pedal ratio.
- Brake pedal weight: 2.20 lbs.
- Clutch pedal weight: 1.46 lbs.
- AFCO master cylinders sold separately.



DESCRIPTION	PART #
6:1 FORWARD SINGLE FLOOR BRAKE PEDAL	6610005
6:1 FORWARD SINGLE FLOOR CLUTCH PEDAL	6610006

AFCO Master Cylinders sold separately. See Pages 60-61 for more info.

REPLACEMENT BIAS BAR KITS

DESCRIPTION	PART #
BIAS BAR KIT FOR REVERSE MOUNT PEDAL	6610010
BIAS BAR KIT FOR FORWARD MOUNT PEDAL	6610011



AFCO BRAKES

BRAKE ACCESSORIES

BRAKE SYSTEM FITTINGS



DESCRIPTION	APPLICATION	PART #
1. 1/8" NP TO -4 AN	AFCO F22, F33, F88 & ALUMINUM CALIPERS	7010-0001
1A. 1/8" NP TO -3 AN	AFCO F22, F33, F88 & ALUMINUM CALIPERS	7010-0002
2. 3/16" LINE TO -3 AN	CHASSIS MOUNT	7010-0003
2B. 3/16" LINE TO -4 AN	CHASSIS MOUNT	7010-0004
3. 7/16" SAE BANJO BOLT	GM STEEL CALIPERS	7010-0013*
4. 10MM - 1.50 X -4 AN	SMALL GM METRIC CALIPERS	7010-0007*
4B. 7/16" SAE TO -4 AN	GM STEEL CALIPERS	7010-0032
5. 3/8" OR 10MM BANJO TO -4 AN	SMALL GM METRIC CALIPERS	7010-0014
6. 7/16" SEALING WASHER (6 PK)	FITS 7/16 BANJO BOLT	7010-0036
6B. 10MM SEALING WASHER (6 PK)	FITS 10MM BANJO BOLT	7010-0037
7. 1/8" NP TO -4 AN TALL (90°)	AFCO F22, F33, F88 & ALUMINUM CALIPERS	7010-0017
8. 3/16" LINE TO -4 AN	LONG CHASSIS MOUNT	7010-0005
9. 7/16" BANJO TO -4 AN	GM STEEL CALIPERS	7010-0009
9B. 7/16" BANJO TO -3 AN	GM STEEL CALIPERS	7010-0010
10. 1/8" NP BLEED VALVE	AFCO METRIC ALUMINUM CALIPERS	7010-0022

DESCRIPTION	APPLICATION	PART #
11. 10MM - 1.50 BANJO BOLT	SMALL GM METRIC CALIPERS	7010-0015*
12. 3/8" - 24 BANJO BOLT	GM CALIPERS	7010-0016*
13. 3/16" INV. FLARE TEE	3/16" BRAKE LINE	40251
14. 1/8" FP TEE	BRAKE LINE	85100X
15. 1/8" MP X (2) 3/16" INV FL	BRAKE BIAS PANEL	85160X-3
16. 1/8" FP X 1/4" FP	BRAKE GAUGES	85160X-2
17. 1/8" MP X 3/16" INV FL FP	STRAIGHT MASTER CYLINDER LINE FITTING	7010-0026
18. 1/8" - NPT MALE - 3 MALE (45°)	ALUMINUM BRAKE CALIPER FITTING	6680001
19. 1/8" - NPT MALE - 4 MALE (45°)	ALUMINUM BRAKE CALIPER FITTING	6680002
20. 1/8" - NPT MALE - 3 MALE	ALUMINUM BRAKE CALIPER FITTING	6680003
21. 1/8" - NPT MALE - 4 MALE	ALUMINUM BRAKE CALIPER FITTING	6680004
22. 1/8" - NPT MALE - 3 MALE (90°)	ALUMINUM BRAKE CALIPER FITTING	6680005
23. 1/8" - NPT MALE - 4 MALE (90°)	ALUMINUM BRAKE CALIPER FITTING	6680006
24. MT 10 MALE - 3 AN MALE	ALUMINUM BRAKE CALIPER FITTING	6680007

*THESE FITTINGS REQUIRE SEALING WASHERS AND ARE SHIPPED WITH WASHERS INCLUDED.

STEEL METRIC CALIPER FITTINGS AND HARDWARE

DESCRIPTION	PART #
METRIC CALIPER COPPER WASHER (6 QTY)	7010-0036
METRIC CALIPER STRAIGHT FITTING	7010-0007
METRIC CALIPER BANJO FITTING	7010-0014
METRIC CALIPER BANJO BOLT	7010-0015
METRIC CALIPER CALIPER BOLT	10160
CALIPER PRESSURE GAUGE	85161
METRIC CALIPER ADAPTER KIT	7010-0050
GM METRIC LIGHTWEIGHT REBUILD KIT 2-3/4"	6690312
MT 10 MALE - 3 AN MALE	6680007

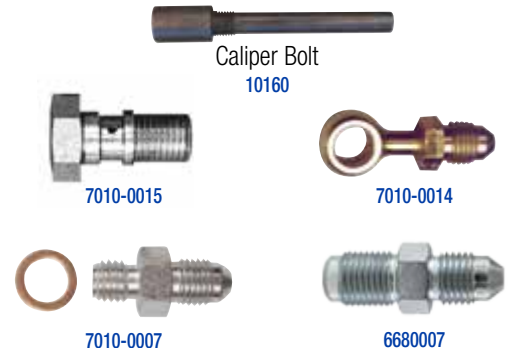

BRAKE SYSTEM FITTINGS & COMPONENTS

M. C. LINE FITTINGS

- 1/8" NP to 3/16" inverted flare brake line.
- Fits AFCO, U.S. Brake, Howe, CNC and Wilwood masters.



DESCRIPTION	PART #
STRAIGHT	7010-0026
90°	7010-0027

STEEL BRAIDED BRAKE LINE - AN 3 & AN 4



DESCRIPTION	END TYPE	PART #
18" AN 3	STRAIGHT ENDS	40265-18
24" AN 3	STRAIGHT ENDS	40265-24
18" AN 3	90 DEG ON 1 END	40264-18
AN 4	STRAIGHT ENDS	40262-18
24" AN 4	STRAIGHT ENDS	40262-24
36" AN 4	STRAIGHT ENDS	40262-36
18" AN 4	90 DEG ON 1 END	40263-18
24" AN 4	90 DEG ON 1 END	40263-24

CALIPER PRESSURE GAUGE & BLEEDER ADAPTERS

- Kit allows for use of the 85161 Brake Pressure Gauge w/ GM Metric Calipers.
- Easily determine brake pressure at the calipers.
- Accurately determine optimal settings for balance bars and proportioning valves.
- Needed to troubleshoot your brake system.



DESCRIPTION	PART #
CALIPER PRESSURE GAUGE	85161
ADAPTER KIT 4 PACK (FOR METRIC CALIPERS)	6670150

BRAKE SHUT-OFF VALVE

- Stainless steel ball.



DESCRIPTION	PART #
BRAKE SHUT-OFF VALVE	40199

CLUTCH SLAVE HOSE KIT



DESCRIPTION	PART #
36" CLUTCH MASTER CYLINDER TO CLUTCH SLAVE CYLINDER HOSE	40280

BRAKE FITTING CLIP

Clips work with 40277, 7010-0004, 7010-0003 to secure fit to chassis.

DESCRIPTION	PART #
CLIP (4)	40260
CLIP (25)	40261



ANDY ESSARY

Andy Essary and Midwest Chassis have teamed up to build a very potent Firebird and are likely to go deep in the rounds of competition at each event where they compete. "We rely on AFCO to deliver performance in every part."



AFCO COOLING

ALUMINUM RADIATORS

Every AFCO radiator is built from detailed, computer-designed specifications and use precision CNC laser-cut parts for exact tolerances. We never stamp tanks. Our tanks are either laser-cut and precision-welded or formed using a "drawn" technique that keeps a uniform thickness and eliminates weak spots.

AFCO understands the vital role the radiator plays in protecting the investment you have in your car. That is why we make no excuses or compromises in constructing the best aftermarket radiators in the industry. Don't trust your pride and joy to anything less than AFCO quality!



FROM CORE TO FINISHED PRODUCT...

AFCO is the ONLY RACING COMPANY that controls the ENTIRE MANUFACTURING PROCESS!

MADE IN THE USA

Quality control and strict production tolerances are key to developing a premium product. Controlling these aspects in-house means AFCO radiators are produced to the highest standards without compromise.



100% ALUMINUM CONSTRUCTION

By using a modern furnace-brazed process, all AFCO radiators feature all-aluminum construction without the need for epoxy. Not only does this make for a lighter radiator, but the common material bonding provides for increased thermal efficiency as well.



ADVANCED MANUFACTURING

Our robotic welding cell for high volume production features a new Fanuc Robot and CMT technology. We also have water jet, laser cut, CNC brake and other capabilities. Our engineering professionals use the most advanced platforms, such as PRO-E, to design the most innovative products in the industry.



PREMIUM QUALITY

AFCO produces high quality radiators and cores. These cores are epoxy free and defect free. Each part goes through our stringent quality control process. We pressure-test every one of our radiators to ensure that our customers will keep their cool on the track.

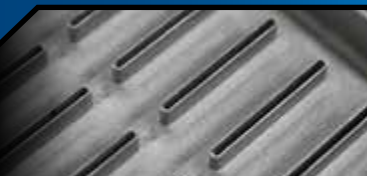

SPECIAL APPLICATIONS

In-house design and fabrication allows us to conceptualize, prototype, test, and manufacture custom cooling systems for a wide variety of applications. If you have a specialty radiator need, AFCO can deliver.



STATE-OF-THE-ART ALUMINUM BRAZING

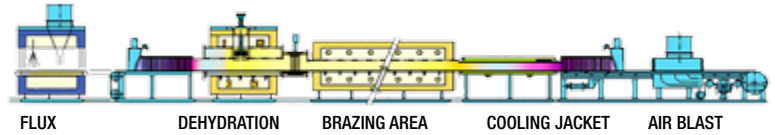
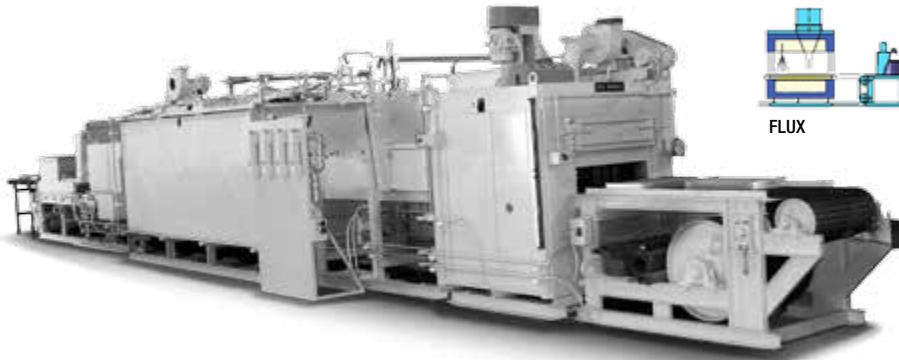

FURNACE SPECIFICATIONS

30" Wide Belt
8" Pass Height
18-22 Cores/Hour

STAINLESS STEEL "HOTBOX" DATA RECORDER

Brazing profiles are created for each core based on the total mass weight. The furnace temperatures and belt speeds are adjusted based on feedback from a data recorder. The hotbox ensures a quality braze profile for each core.



FURNACE CONTROLS

The furnace is controlled via a touch screen HMI panel. Each component uses a unique brazing profile that is developed and saved as a recipe. This recipe includes belt speed, zone temperatures, and nitrogen flow. The system software also provides features such as historical brazing data and maintenance scheduling.



OUR CORE STANDARDS

Every part of a core is important, but the quality of the headers is an absolute must. The tube slots must be punched with a maximum of .002" clearance for a precise tube fit. While others use single sided clad material, AFCO uses double sided clad for all the headers. This provides a fillet joint around the tube on both sides of the header, doubling the strength of the joint. You simply cannot build a better, stronger core. The use of .080 double clad material and extruded side channels provides a core strong enough to handle over one million pressure cycles, without a tube-to-header joint failure.



Serpentine
Louvered
Fin @ 16psi



Clad Fillets
on Both
Sides



Double
Clad
.080 Headers

DRAG RACING COOLING

DRAGSTER / ROADSTER RADIATOR - AFCO MEETS THE COOLING CHALLENGE

Cooling a drag racing engine presents unique challenges. To meet these challenges, AFCO has developed several radiator models dedicated to drag racing applications. Designed to be compact and highly efficient, these radiators provide the needed cooling to keep you cool at the line without sacrificing performance due to excess weight and coolant.



AFCO's Double pass "Dragster" radiator is specifically designed for roadsters and dragsters. It features a 16 fin per inch, no epoxy core for maximum efficiency, as well as a high CFM / low AMP draw fan & shroud combo. This radiator comes complete with a fan on/off switch, 4 mounting bosses and 3/4" FNPT (Female National Pipe Thread) inlet/outlet.

OVERALL HEIGHT	TANK HEIGHT	WIDTH	TANK THICKNESS	FILLER LOC.	INLET SIZE & LOC.	OUTLET SIZE & LOC.	DRY WEIGHT		PART #
21"	21"	17-1/4"	2-1/8"	NONE	3/4" FNPT L	3/4" FNPT R	12.2 LBS.	RAD W/ FAN & SHROUD	80108N
21"	21"	17-1/4"	2-1/8"	NONE	3/4" FNPT L	3/4" FNPT R	12.2 LBS.	RAD ONLY	80108NR
FAN KIT (14" S-BLADE, 1,550 CFM, 10 AMP DRAW, POLISHED ALUMINUM SHROUD)								FAN & SHROUD ONLY	80108NFAN

AFCO DRAG RACING POWER-ADDER RADIATOR

This specialty radiator is commonly used in turbo-charged drag racing applications. Its compact size and efficiency makes it a popular choice for many chassis builders.

- Optimized fin count for maximum cooling capacity.
- Single-row construction facilitates lightweight design.
- 100% TIG-welded, no epoxy.
- Factory pressure tested.



80176
8" diameter

80260N

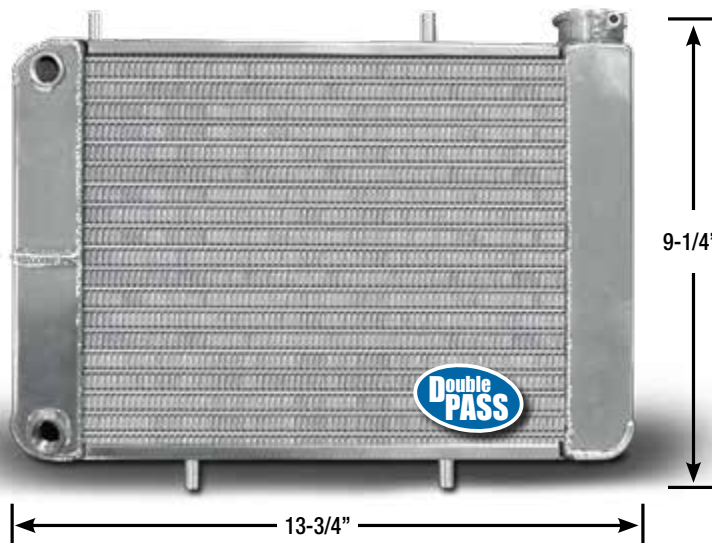

DESCRIPTION	PART #
13-3/4" X 9-1/4" DRAG RADIATOR	80260N
8" S-BLADE ELECTRIC FAN (1155 CFM)	80176

SCIROCCO-STYLE DRAG RACING RADIATORS

AFCO offers several versions of the popular “Scirocco-style” radiator. These radiators are 12-5/8” high x 21-1/2” wide and are available in configurations for Chevy, Ford, and Chrysler applications. The all-aluminum furnace brazed core design (no epoxy) provides maximum cooling protection for the most demanding door-slammers. These radiators have 100% TIG-welded tanks and brackets. The Lightweight (LWN) versions remove 4 pounds from the nose of the car while keeping the same cooling performance. #80104NFAN is a fan/shroud kit that bolts up perfectly to the 1/4” bungs. N models have 2 rows of 1” tubes and the LWN models have 1 row of 1.5” tubes.



80104N - (21-1/2” x 12-5/8”)

80104NFAN - (12” fan and shroud combo)
Fits all AFCO Scirocco-style radiators below.

- Double pass for maximum cooling in a compact, lightweight package.
- Lightweight versions remove 4 lbs. from the nose of the car!
- Sturdy TIG-welded 2” “foot” mounts.
- Four 1/4” - 20 mounting bungs.
- Stainless hardware & drain included.
- No epoxy construction.
- 100% TIG-welded.



80104N

80104NA

80105N

80107N



Lightweight

80104LWN

Lightweight

80104LWNA

Lightweight

80105LWN

Lightweight

80107LWN

OVERALL HEIGHT	TANK HEIGHT	TANK WIDTH TOP	TANK WIDTH BOTTOM	WIDTH WITH FLANGES	TANK THICKNESS	FILLER LOC.	INLET SIZE & LOC.	OUTLET SIZE & LOC.	WET WEIGHT	PART #
12-5/8"	12-5/8"	21-1/2"	21-1/2"	25-1/2"	3"	L	1-1/2" R	1-3/4" R	14.5 LBS.	80104N
12-5/8"	12-5/8"	21-1/2"	21-1/2"	25-1/2"	3"	L	1-1/4" R	1-1/4" R	14.5 LBS.	80104NA
12-5/8"	12-5/8"	21-1/2"	21-1/2"	25-1/2"	3"	R	1-1/2" L	1-3/4" L	14.5 LBS.	80105N
12-5/8"	12-5/8"	21-1/2"	21-1/2"	25-1/2"	3"	NONE	1-1/4" R	1-1/4" R	14.5 LBS.	80107N
12-5/8"	12-5/8"	21-1/2"	21-1/2"	25-1/2"	2"	L	1-1/2" R	1-3/4" R	10.5 LBS.	80104LWN
12-5/8"	12-5/8"	21-1/2"	21-1/2"	25-1/2"	2"	L	1-1/4" R	1-1/4" R	10.5 LBS.	80104LWNA
12-5/8"	12-5/8"	21-1/2"	21-1/2"	25-1/2"	2"	R	1-1/2" L	1-3/4" L	10.5 LBS.	80105LWN
12-5/8"	12-5/8"	21-1/2"	21-1/2"	25-1/2"	2"	NONE	1-1/4" R	1-1/4" R	10.5 LBS.	80107LWN

FAN & SHROUD KIT (FITS ALL ABOVE).

80104NFAN

PERFORMANCE-FIT RADIATORS

AFCO Performance-Fit radiators are designed to be easily adapted to many applications. Perfect for the street, the strip, or anything in between.

- 2 row core.
- 2-1/4" thick core.
- 100% TIG-welded.
- Drain petcock included.
- 100% aluminum with no epoxy construction.
- 100% pressure-tested.

2" mounting flanges on most models.

Built-in fin covers (top and bottom plates) provide a great finish and aid installation.



80100FNP - (22" x 18-1/2")

MOPAR

'64 - '69 Barracuda
A-Body Valiant
A-Body Duster
A-Body Scamp



80101NP - (27-1/2" x 18-3/4")

CHEVY

'67 - '69 BBC Camaro (AC)

PONTIAC

'67 - '69 Firebird (AC)



80101FNP - (27-1/2" x 18-3/4")

EARLY FORDS

CUSTOMS

SPECIALTY MARKETS



80103NP - (26" x 18-3/4")

CHEVY

'59 - '70 Impala / Belair
'67 - '69 SBC Camaro

PONTIAC

'67 - '69 Firebird



80103FNP - (26" x 18-3/4")

MOPAR

'62 - '64 Polara / Savoy
'62 - '70 Belvedere
'65 - '74 Satellite / Coronet / Charger / Road Runner



80127NP - (24" x 18-1/2")

BUICK

'65 - '67 Regal / Gran Sport

MOPAR

'70 - '74 Challenger (Small Block)
'70 - '74 Barracuda (Small Block)

CHEVY

'62 - '72 Nova / Chevy II



80127FNP - (24" x 18-1/2")

MOPAR

'70 - '74 Challenger (Big Block)
'70 - '74 Barracuda (Big Block)

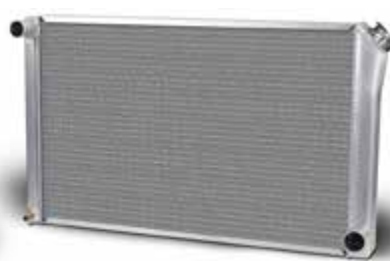

80102NP - (31" x 18-3/4")

CHEVY

'68 - '79 Nova/Nova SS
'68 - '87 Chevelle / El Camino
'70 - '81 Camaro
'70 - '87 Monte Carlo
'71 - '74 Impala/Belair

OLDSMOBILE

'65 - '79 Delta 88/98
'66 - '87 Cutlass/442
'72 - '77 Omega/Omega SX

PONTIAC

'65 - '87 Grand Prix
'65 - '86 Catalina/Bonneville
'67 - '69 Firebird
'68 - '72 GTO/Lemans
'70 - '81 Firebird/Trans Am
'73 - '80 Grand AM

OVERALL HEIGHT	TANK HEIGHT	CORE WIDTH	TANK WIDTH TOP	TANK WIDTH BOTTOM	WIDTH WITH FLANGES	TANK THICKNESS	FILLER LOC.	INLET SIZE & LOC.	OUTLET SIZE & LOC.	DRY WEIGHT	PART #
20"	18-1/2"	17-7/8"	22-3/8"	21-1/2"	25-13/32"	3"	L	1-1/2" L	1-3/4" R	11.20 LBS.	80100FNP
20"	18-1/2"	22-3/8"	27-1/2"	27-1/2"	31-1/2"	3"	L	1-1/2" R	1-3/4" L	14.20 LBS.	80101FNP
20"	18-1/2"	22-3/8"	27-1/2"	27-1/2"	31-1/2"	3"	R	1-1/2" L	1-3/4" R	14.20 LBS.	80101NP
18-11/16"	18-1/2"	27-1/2"	32"	31-1/16"	N/A	3"	R	1-1/2" L	1-3/4" R	15.50 LBS.	80102NP
20"	18-1/2"	22-3/8"	26-3/4"	26"	30"	3"	L	1-1/2" R	1-3/4" L	13.75 LBS.	80103FNP
20"	18-1/2"	22-3/8"	26-3/4"	26"	30"	3"	R	1-1/2" L	1-3/4" R	13.75 LBS.	80103NP
20"	18-1/2"	20"	24-1/4"	23-1/2"	27-1/2"	3"	R	1-1/2" L	1-3/4" R	14.50 LBS.	80127NP
20"	18-1/2"	20"	24-1/4"	23-1/2"	27-1/2"	3"	L	1-1/2" R	1-3/4" L	14.50 LBS.	80127FNP

CORE MEASUREMENTS DOES NOT INCLUDE TANKS.

*Always measure for your application — AFCO Performance Series Radiators may require some modifications and / or fabricating for proper fit.

**For full, show-quality polished finish, add a "Z" to the end of the radiator part number.

LIGHTWEIGHT SINGLE ROW CORE

At almost half the weight of a 2-row radiator, single row radiators are ideal for alcohol fueled cars or cars with limited cooling requirements.



80100LWN - (21-1/2" x 20")



80100LWFN - (21-3/8" x 20")



80103LWN - (26-1/4" x 19-3/4")



80111N - (27-1/4" x 18-5/8")



80111FN - (27-1/4" x 18-5/8")



80127LWN - (23-5/8" x 20")

OVERALL HEIGHT	CORE WIDTH	TANK HEIGHT	TANK WIDTH TOP	TANK WIDTH BOTTOM	TANK THICKNESS	FILLER LOC.	INLET SIZE & LOC.	OUTLET SIZE & LOC.	OUTLET ANGLE UP / IN	DRY WEIGHT	PART #
20"	18"	18-1/2"	22-7/8"	21-1/2"	1-7/8"	R	1-1/2" L	1-3/4" R	20°/10°	6.3 LBS.	80100LWN*
20"	18"	18-1/2"	22-7/8"	21-3/8"	1-7/8"	L	1-1/2" R	1-3/4" L	20°/10°	6.3 LBS.	80100LWFN*
19-3/4"	23-3/8"	18-3/4"	26-1/4"	26-1/4"	2-5/16"	R	1-1/2" L	1-3/4" R	30°/10°	8.8 LBS.	80103LWN*
18-5/8"	23-1/2"	18-5/8"	27-5/16"	27-1/4"	2-7/16"	R	1-1/2" L	1-3/4" R	30°/10°	11 LBS.	80111N*
18-5/8"	23-1/2"	18-5/8"	27-5/16"	27-1/4"	2-7/16"	L	1-1/2" R	1-3/4" L	30°/10°	11 LBS.	80111FN*
20"	18"	18-1/2"	23-5/8"	23-5/8"	1-5/8"	R	1-1/2" L	1-3/4" R	30°/10°	6.9 LBS.	80127LWN*

*1.25" CORES.

FAN SHROUDS

Add a High CFM fan shroud for a simple installation.

- Shroud is 3/4" deep.
- Fan is 3-3/16" deep.
- Total depth from core face is 4".

SIZE

CUSTOM SIZE FAN & SHROUD
 CUSTOM SIZE DUAL FAN & SHROUD

PART #

80110FS
 80110FSD

80100NP & 80100FNP, 18.25" X 18.625"
 80127NP & 80127FNP, 20" X 18.625"
 80101NP, 80101FNP, 80103NP & 80103FNP, 22.38" X 18.75"
 27.43" X 18.75" - FITS 80102NP

80402FAN
 80404FAN
 80406FAN
 80409FAN*

*TOTAL DEPTH FROM CORE FACE IS 4-1/8", SHROUD IS 3/4".



UNIVERSAL SINGLE PASS RADIATORS

Universal Radiators are built with two 1" rows for a total core thickness of 2-1/4" and feature 3" tanks.

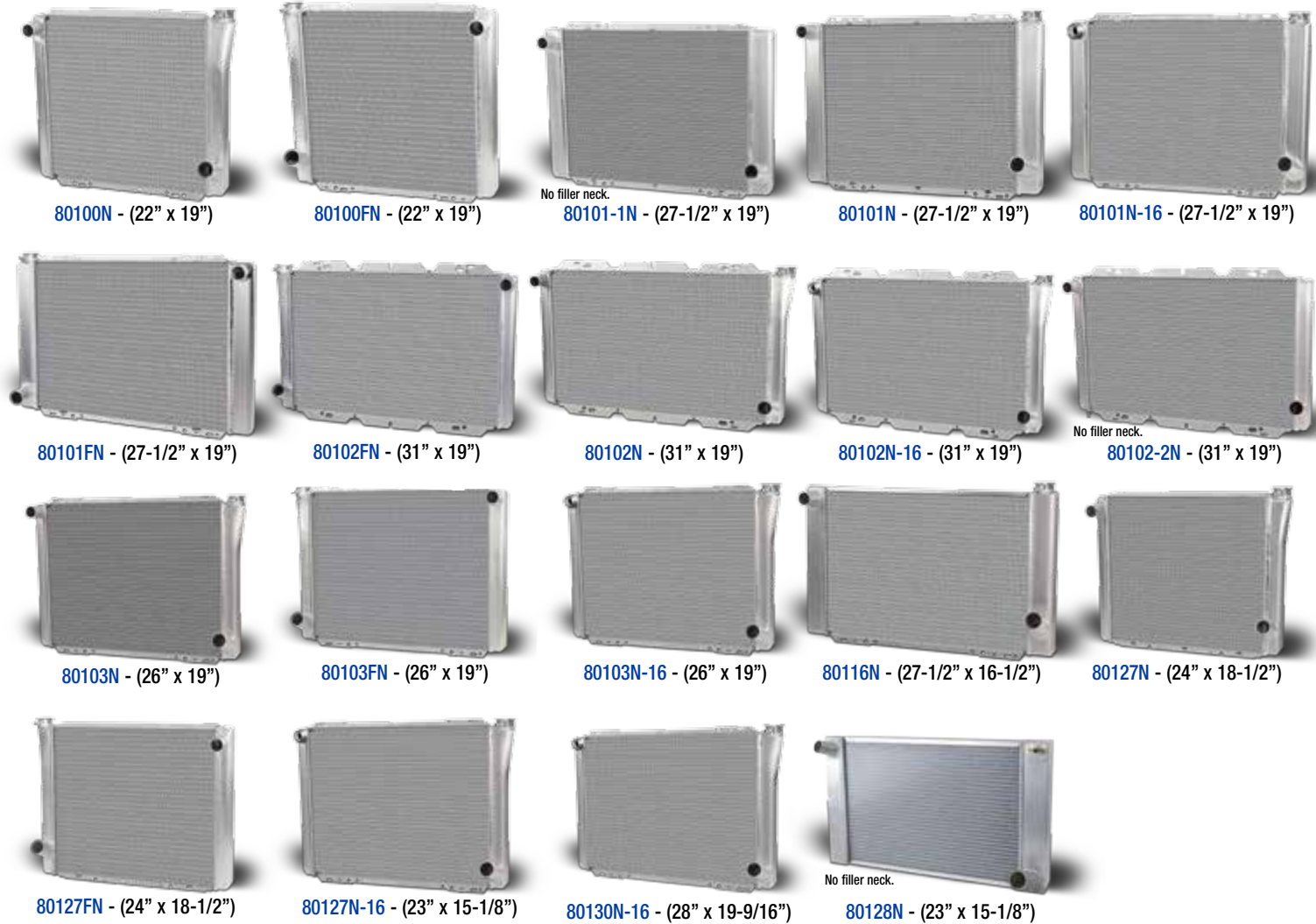

OVERALL HEIGHT	CORE WIDTH	TANK HEIGHT	TANK WIDTH TOP	TANK WIDTH BOTTOM	TANK THICKNESS	FILLER LOC.	INLET SIZE & LOC.	OUTLET SIZE & LOC.	OUTLET ANGLE UP / IN	DRY WEIGHT	PART #
20"	17-7/8"	18-1/2"	22-3/8"	21-1/2"	3"	R	1-1/2" L	1-3/4" R	30°/10°	11.2 LBS.	80100N
20"	17-7/8"	18-1/2"	22-3/8"	21-1/2"	3"	L	1-1/2" R	1-3/4" L	30°/10°	11.2 LBS.	80100FN
20"	22-3/8"	18-1/2"	27-1/2"	27-1/2"	3"	NONE	1-1/2" L	1-3/4" R	30°/10°	13.7 LBS.	80101-1N
20"	22-3/8"	18-1/2"	27-1/2"	27-1/2"	3"	R	1-1/2" L	1-3/4" R	30°/10°	13.6 LBS.	80101N
20"	22-3/8"	18-1/2"	27-1/2"	27-1/2"	3"	R	16 AN-M L	1-3/4" R	30°/10°	13.6 LBS.	80101N-16
20"	22-3/8"	18-1/2"	27-1/2"	27-1/2"	3"	L	1-1/2" R	1-3/4" L	0°	13.6 LBS.	80101FN
21"	27-1/2"	18-1/2"	32"	31"	3"	L	1-1/2" R	1-3/4" L	30°/10°	15 LBS.	80102FN
21"	27-1/2"	18-1/2"	32"	31"	3"	R	1-1/2" L	1-3/4" R	30°/10°	15 LBS.	80102N
21"	27-1/2"	18-1/2"	32"	31"	3"	R	16 AN-M L	1-3/4" R	30°/10°	15 LBS.	80102N-16
21"	27-1/2"	18-1/2"	30-7/8"	30-7/8"	3"	NONE	1-1/2" L	1-3/4" R	30° UP	15 LBS.	80102-2N
20"	22-3/8"	18-1/2"	26-3/4"	26"	3"	R	1-1/2" L	1-3/4" R	30°/10°	13.2 LBS.	80103N
20"	22-3/8"	18-1/2"	26-3/4"	26"	3"	L	1-1/2" R	1-3/4" L	30°/10°	13.2 LBS.	80103FN
20"	22-3/8"	18-1/2"	26-3/4"	26"	3"	R	16 AN-M L	1-3/4" R	30°/10°	13.2 LBS.	80103N-16
17-5/16"	22-3/8"	15-7/8"	27-1/2"	27-1/2"	3"	R	1-1/2" L	1-3/4" R	30°/10°	14.1 LBS.	80116N
20"	20"	18-1/2"	24-1/4"	23-1/2"	3"	R	1-1/2" L	1-3/4" R	30° UP	14.1 LBS.	80127N
20"	20"	18-1/2"	24-1/4"	23-1/2"	3"	L	1-1/2" R	1-3/4" L	30° UP	14.1 LBS.	80127FN
20"	20"	18-1/2"	24-1/2"	23-1/2"	3"	L	16 AN R	1 3/4" R	30/10	14.1 LBS.	80127N-16
19-9/16"	24-3/8"	18-1/2"	28-3/4"	28"	3"	R	16 AN R	1-3/4" R	30°/10°	14.3 LBS.	80130N-16

FOR EXTRA STEERING BOX CLEARANCE

15-1/8"	17-7/8"	15-1/6"	22-7/8"	22-7/8"	3"	NONE	1-1/2" L	1-3/4" R	20°/ 25°	9.75	80128N*
---------	---------	---------	---------	---------	----	------	----------	----------	----------	------	---------

* ANGLED DRIVER TANK - INLET IS ANGLED 15° UP 10° OUT.

UNIVERSAL DOUBLE PASS RADIATORS

AFCO double pass radiators give increased cooling over standard type radiators, with less than 2 oz. of added weight. Common temperature drops are 10-20° F when replacing a standard configuration radiator with equal core size. This keeps your mind off the water temperature and puts it on the race track.

HOW IT WORKS

Double pass radiators gain their efficiency by first passing the fluid through the top half of the radiator and then the bottom half, giving the radiator the ability to dissipate heat twice.

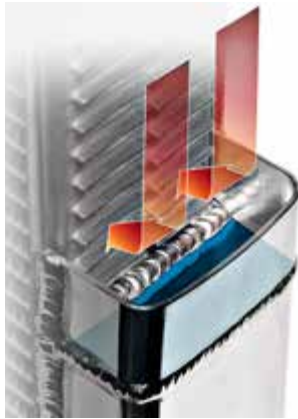
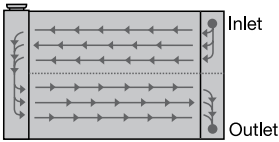

We use our exclusive 360 degree TIG-welded baffle that splits the radiator core into two sections. This 360 degree baffle in a sense creates two radiators out of one and ensures that you won't have any coolant that has entered the radiator but never made it across the core. This is superior to utilizing silicone to seal internal baffles, or worse, a partial weld that allows the coolant to bypass the radiator core completely.



80100NDP - (22" x 19")

Available in "Thermal Coating" - Call for details.

All AFCO Radiators are available with an optional black "Thermal Coating" finish for improved cooling.



Swivel-neck Aluminum Thermostat Housings

Allows for easy installation of Double Pass Radiators.

80312-15 (15° Neck)

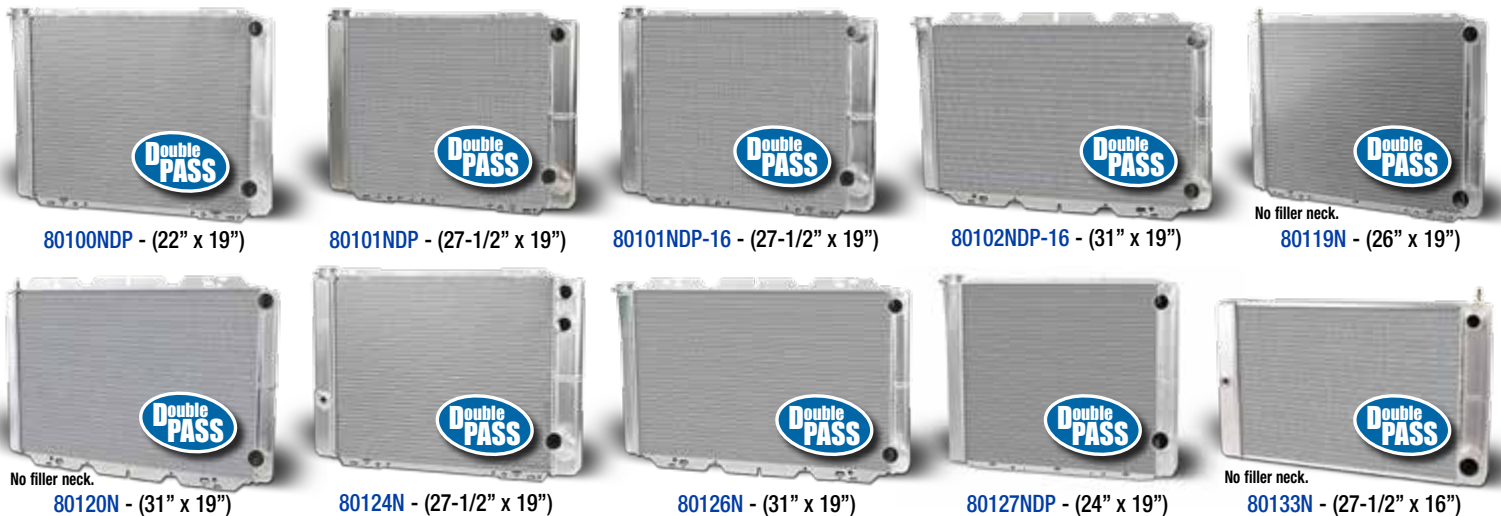

80100NDP - (22" x 19")

80101NDP - (27-1/2" x 19")

80101NDP-16 - (27-1/2" x 19")

80102NDP-16 - (31" x 19")

No filler neck. 80119N - (26" x 19")

No filler neck. 80120N - (31" x 19")

80124N - (27-1/2" x 19")

80126N - (31" x 19")

80127NDP - (24" x 19")

No filler neck. 80133N - (27-1/2" x 16")

OVERALL HEIGHT	CORE WIDTH	TANK HEIGHT	TANK WIDTH TOP	TANK WIDTH BOTTOM	TANK THICKNESS	FILLER LOC.	INLET SIZE & LOC.	OUTLET SIZE & LOC.	OUTLET ANGLE UP / IN	DRY WEIGHT	PART #
20"	17-7/8"	18-1/2"	22-1/4"	21-1/2"	3"	L	1-1/2" R	1-3/4" R	30°/10°	11.3 LBS.	80100NDP
20"	22-3/8"	18-1/2"	27-1/2"	27-1/2"	3"	L	1-1/2" R	1-3/4" R	30°/10°	13.7 LBS.	80101NDP
20"	22-3/8"	18-1/2"	27-1/2"	27-1/2"	3"	L	16 AN-M R	1-3/4" R	30°/10°	13.7 LBS.	80101NDP-16
21"	27-1/2"	18-1/2"	31-3/4"	31"	3"	L	16 AN-M R	1-3/4" R	30°/10°	15 LBS.	80102NDP-16
20"	22-3/8"	18-1/2"	25-3/4"	25-3/4"	3"	NONE*	1-1/2" R	1-3/4" R	30°/10°	13.2 LBS.	80119N*
21"	27-1/2"	18-1/2"	30-3/4"	30-3/4"	3"	NONE*	1-1/2" R	1-3/4" R	30°/10°	15 LBS.	80120N*
20"	22-3/8"	18-1/2"	26-3/4"	25-7/8"	3"	L	1-1/2" R	1-3/4" R	30°/10°	13.2 LBS.	80124N
21"	27-1/2"	18-1/2"	31-3/4"	31"	3"	L	1-1/2" R	1-3/4" R	30°/10°	15 LBS.	80126N
20"	20"	18-1/2"	24-1/4"	23-1/2"	3"	L	1-1/2" R	1-3/4" R	30° UP	14.1 LBS.	80127NDP
16"	22-3/8"	16"	27-1/2"	27-1/2"	3"	NONE	1-1/4" R	1-1/2" R	0°	13.2 LBS.	80133N**

*1/4" FNT PIPE FITTED WITH AIR BLEED.

**TWO 2/4" FP TEMP BUNG.

HIGH PERFORMANCE COOLING

MUSTANG RACING RADIATORS

This radiator was designed to fit Fox Body Mustangs ('79-'93) with little to no fabrication required. This radiator was designed as an easy "race-fit" application for Fox Body Mustangs ('79-'93). Fabricating a new top bracket or purchase of #80109B bracket sold below is required to install. Due to the thickness of this radiator, fitment on air-conditioned cars retaining the factory fan shroud requires this shroud to be notched for air compressor clearance.

- Perfect choice for your engine swap project.
- Stock hose inlet and outlets.
- Exceeds factory efficiency - 40% larger core!

ENGINE	HEIGHT	WIDTH	CORE SIZE	PART #
CHEVY (SBC & BBC)	18-1/2"	28-5/8"	24-1/2"	80109N
FORD (SBF & BBF)	18-1/2"	28-5/8"	24-1/2"	80109FN
CHEVY (LSX)	18-1/2"	28-5/8"	24-1/2"	80109NLS
UPPER RADIATOR BRACKET				80109B
SINGLE FAN SHROUD				80109FS
DUAL FAN SHROUD				80109FSD



80109FS

80109FSD

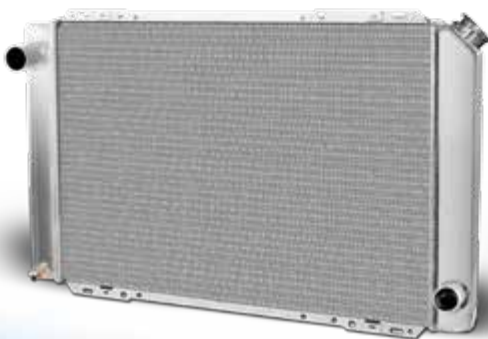

80109N - (28-5/8" x 18-1/2")



80109FN - (28-5/8" x 18-1/2")

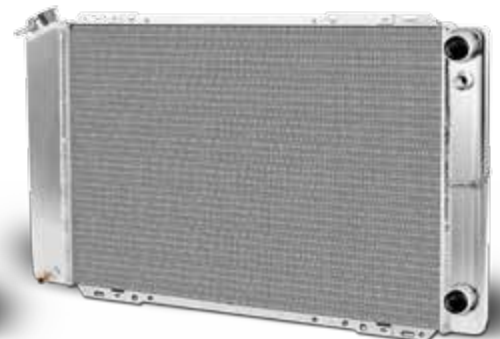

80109NLS - (28-5/8" x 18-1/2")



AFCO DIRECT-FIT HIGH PERFORMANCE RADIATORS

AFCO Direct-Fit High Performance radiators are engineered and manufactured in-house. During the design phase, careful consideration is paid to ensure the finished product maximizes cooling, streamlines installation, and allows years of satisfaction. You will not find a better radiator on the market.

'79-'93 & '94-'95 MUSTANG RADIATORS



81270



81271



- **NA** (No Fan & Shroud: Std.)
- **SS** (Single Satin:)
- **SP** (Single Polished:)
- **SB** (Single Black:)
- **DS** (Dual Fan Satin:)
- **DP** (Dual Fan Polished:)
- **DB** (Dual Fan Black:)

See page 115 for wire harness options.



BUILD YOUR PART NUMBER

'73 - '93	81270 28-3/4"(w) x 16-7/8"(h)
'94 - '95	81271 29-1/4"(w) x 16-1/2"(h)

BASE NUMBER

- **S** (Satin: Std.)
- **P** (Polished:)
- **B** (Black:)
- **F** (Fan & Shroud Only)

FINISH CHOICES

ELECTRIC FAN & SHROUD CHOICES

WITH OR WITHOUT BUILT-IN TRANSMISSION COOLER

- **N** (No Trans. Cooler: Std.)
- **Y** (w/ Trans. Cooler: + \$70)

BUILT-IN TRANS. COOLER

'97-'04 MUSTANG RADIATORS

NEW!



- **S** (Satin: Std.)
- **P** (Polished:)
- **B** (Black:)
- **F** (Fan & Shroud Only)

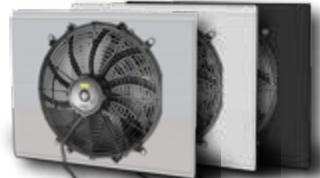

- **NA** (No Fan & Shroud: Std.)
- **SS** (Single Satin:)
- **SP** (Single Polished:)
- **SB** (Single Black:)
- **DS** (Dual Fan Satin:)
- **DP** (Dual Fan Polished:)
- **DB** (Dual Fan Black:)

See page 115 for wire harness options.



BUILD YOUR PART NUMBER

STARTING AT	80291 29-3/4"(w) x 17-3/4"(h)
\$574⁹⁹	

BASE NUMBER

FINISH CHOICES

ELECTRIC FAN & SHROUD CHOICES

WITH OR WITHOUT BUILT-IN TRANSMISSION COOLER

- **N** (No Trans. Cooler: Std.)
- **Y** (w/ Trans. Cooler: + \$70)

BUILT-IN TRANS. COOLER

'05 - '09 MUSTANG RADIATORS

- Aluminum construction and TIG-welded.
- Mounts in the factory location.
- Accepts factory fan shroud.
- Two row 1" tube core.
- 28.90" wide x 19.12" tall x 3" thick tanks.
- Installation time less than 1 hour.
- Radiator has condenser mounting.
- Detailed instructions included.



FINISH	HEIGHT	WIDTH	PART #
SATIN	18-1/4"	29"	81281N
POLISHED	18-1/4"	29"	81281Z
BLACK	18-1/4"	29"	81281B

'10 - '14 MUSTANG RADIATORS

- Mounts in the factory location.
- Accepts factory fan shroud.
- Mounting for condenser on the radiator.
- Mounting for external transmission cooler on the radiator.
- Two row 1" tube core.
- 2.61" thick tanks.
- Installation time less than 1 hour.
- Detailed instructions included.

FINISH	HEIGHT	WIDTH	PART #
SATIN	20.88"	28.81"	81283N
POLISHED	20.88"	28.81"	81283Z
BLACK	20.88"	28.81"	81283B

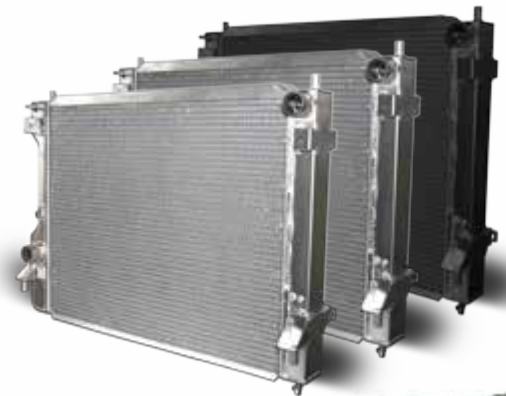

'10 - '11 CAMARO RADIATORS

- Mounts in the factory location.
- Accepts factory fan shroud.
- Condenser mounts on the radiator.
- In-tank transmission cooler standard for automatic and manual cars.
- Two row 1" tube core.
- Installation time less than 1 hour.
- Detailed instructions included.

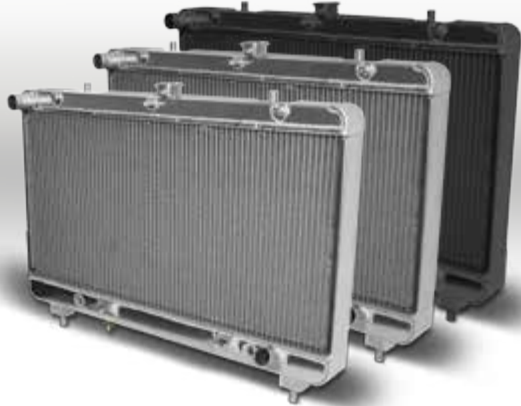

FINISH	HEIGHT	WIDTH	PART #
SATIN	19.56"	30.84"	80259N
POLISHED	19.56"	30.84"	80259Z
BLACK	19.56"	30.84"	80259B

'14 - '16 C7 CORVETTE RADIATORS

- Direct fit radiator, accepts stock mounting hardware, A/C condenser, and fan shroud.
- Single row 1.50" core, twice the thickness of the stock radiator core.
- Will not fit the Z06 Corvette.
- Aluminum construction and TIG-welded.
- Detailed instructions included.



APPLICATION	OVERALL HEIGHT	OVERALL WIDTH	CORE WIDTH	CORE HEIGHT	CORE LENGTH	PART #
C7 CORVETTE SATIN RADIATOR	17-5/16"	26-7/16"	1-1/2"	17-5/16"	22-7/16"	80292N
C7 CORVETTE POLISHED RADIATOR	17-5/16"	26-7/16"	1-1/2"	17-5/16"	22-7/16"	80292Z
C7 CORVETTE BLACK RADIATOR	17-5/16"	26-7/16"	1-1/2"	17-5/16"	22-7/16"	80292B



HEAT EXCHANGERS

Cooler intake temperatures mean more power. It is just that simple. However, providing your engine with cool air to breathe becomes even more difficult when forced induction is involved.

A supercharger utilizes a heat exchanger mounted low in the front grill which is very similar to a small radiator. Coolant flows separate from the main engine cooling system and circulates internally through the intercooler beneath the supercharger.

While the factory supercharger cooling system is adequate in stock configuration, it struggles to keep up with the multitude of popular modifications that not only deliver more power, but also increase the stress and strain on the engine.

To combat the power loss by excessive heat build up in the supercharger and intake system, AFCO focused on upgrading the weakest component in this cooling system, THE HEAT EXCHANGER.



MORE COOLING CAPACITY

FACTORY



AFCO STANDARD



AFCO STANDARD WITH FANS



COOLER INTAKE TEMPERATURES = MORE HORSEPOWER

Easy Bolt-In Installation

AFCO Heat Exchangers mount in factory locations with no cutting or fabrication of any kind — a TRUE BOLT-IN.

Regains Lost Power

By more effectively cooling intake temperatures, AFCO Heat Exchangers keep the air entering the combustion chamber cooler and more dense, even in high-demand situations. AFCO heat exchangers reduce supercharger coolant temperatures by more than 40 degrees.

Allows for More Consistency

After hard acceleration, especially in drag racing applications, AFCO Heat Exchangers allow the supercharger to cool faster and remain at a constant temperature, which means power delivery is more consistent.

Optimized Design

Using years of experience, advanced design, and thorough testing, AFCO Heat Exchangers are designed to promote optimal air flow and cooling by utilizing proper fin count, tube size, core thickness, and fin serration for all applications.

Quality Construction

Of course, as an AFCO product, quality is second to none. AFCO Heat Exchangers are TIG-welded and feature furnace brazed cores with no epoxy. Each unit is pressure tested before it is shipped.

Installation

AFCO Heat Exchanger installation only requires simple hand tools and approximately 1-2 hours. All needed hardware (except replacement fluid) is included along with detailed instructions.

NEED A CUSTOM HEAT EXCHANGER?

AFCO Racing Products offers custom-built heat exchangers.

**Part #
80005**

Base price includes core, tanks, any fin covers, brackets, and all inlets/outlets, bungs and fittings. Comes in standard satin finish.

BUILD YOUR PART NUMBER...
Example: 80005-S-DS

SINGLE PASS



FINISH CHOICES

- S (Satin: Std.)
- P (Polished)
- B (Black)



ELECTRIC FAN & SHROUD CHOICES

- DS (Dual Fan Satin)
- DP (Dual Fan Polished)
- DB (Dual Fan Black)
- NA (No Fan & Shroud: Std.)

**Part #
80006**

Base price includes core, tanks, any fin covers, brackets, and all inlets/outlets, bungs and fittings. Comes in standard satin finish.

BUILD YOUR PART NUMBER...
Example: 80006-S-DS

DOUBLE PASS



FINISH CHOICES

- S (Satin: Std.)
- P (Polished)
- B (Black)



ELECTRIC FAN & SHROUD CHOICES

- DS (Dual Fan Satin)
- DP (Dual Fan Polished)
- DB (Dual Fan Black)
- NA (No Fan & Shroud: Std.)



'03 - '04 COBRA MUSTANG HEAT EXCHANGER

The '03-'04 Cobra model uses a dual pass design. This design improves power by creating a more dense (lower temp.) intake charge versus stock. Our double pass design, combined with total grill covering, will increase the cooling ability of the system to drop your inlet temperatures to near ambient while under boost. A 60-70 degree temperature drop is typical compared to the stock system. This is critical in controlling detonation in a supercharged application.

AFCO Heat Exchangers are now available for serious street performance enthusiasts with supercharged applications. AFCO's design incorporates the latest engineering and technology for enhanced coolant flow and improved thermal stabilization. AFCO Heat Exchangers are available as standard (high performance street) or pro series (drag race and extreme street). There is no drilling, cutting, or fabrication required. Detailed instructions included.

2003-2004 COBRA MUSTANG	DIMENSIONS	PART #
COBRA DOUBLE PASS HEAT EXCHANGER	(L - 31") X (W - 3") X (H - 5-13/16")*	80275NDP
COBRA DOUBLE PASS HEAT EXCHANGER (BLACK)	(L - 31") X (W - 3") X (H - 5-13/16")*	80275NDPB
COBRA DOUBLE PASS HEAT EXCHANGER W/ DUAL FAN KIT**	(L - 31") X (W - 5-3/8") X (H - 5-13/16")**	80275PRO
COBRA DOUBLE PASS HEAT EXCHANGER W/ DUAL FAN KIT (BLACK)**	(L - 31") X (W - 5-3/8") X (H - 5-13/16")**	80275PROB
COBRA HEAT EXCHANGER DUAL FAN KIT (FITS 80275NDP)	(L - 24-1/8") X (W - 2-3/8") X (H - 6")	80275NFAN

*OUTSIDE DIMENSIONS TANK TO TANK, TOP TO BOTTOM & FRONT TO BACK OF CORE. **WIDTH MEASUREMENTS INCLUDE FAN WIDTH.

80275PRO



'07 - '12 COBRA SHELBY GT500 HEAT EXCHANGER

- 350% more cooling area than stock.
- Dual 10" SPAL fans with dual relay wiring harness, only on PRO model.
- There is no drilling, cutting, or fabrication required.
- Detailed instructions included.

2007 & UP SHELBY HEAT EXCHANGER	DIMENSIONS	PART #
SHELBY DOUBLE PASS HEAT EXCHANGER	(L - 26-1/4") X (W - 3") X (H - 8-7/8")*	80280NDP
SHELBY DOUBLE PASS HEAT EXCHANGER (BLACK)	(L - 26-1/4") X (W - 3") X (H - 8-7/8")*	80280NDPB
SHELBY DOUBLE PASS HEAT EXCHANGER W/ FANS	(L - 26-1/4") X (W - 5-3/8") X (H - 11-3/8")**	80280PRO
SHELBY DOUBLE PASS HEAT EXCHANGER W/ FANS (BLACK)**	(L - 26-1/4") X (W - 5-3/8") X (H - 8-7/8")**	80280PROB

*OUTSIDE DIMENSIONS TANK TO TANK, TOP TO BOTTOM & FRONT TO BACK OF CORE. **WIDTH MEASUREMENTS INCLUDE FAN WIDTH.

80280PROB



80280PRO



'99 - '04 F-150 LIGHTNING/HARLEY HEAT EXCHANGERS

The 80245N offers huge gains over the factory model by offering more surface area, volume, and superior core construction. It is a single pass system and can be installed in less than 30 minutes. There is no drilling, cutting, or fabrication required. Detailed instructions included.

The 80249N offers even more cooling capacity by adding a double pass design (uses a baffle to pass the coolant through the core twice). The dual fan kit adds over 1080 CFM of constant airflow to further the cooling system. Detailed instructions included.

1999-2004 F-150 LIGHTNING / HARLEY	DIMENSIONS	SATIN FINISH	BLACK FINISH
LIGHTNING HEAT EXCHANGER	(L - 26-3/8") X (W - 3") X (H - 8-7/8")*	80245N	80245NB
DOUBLE PASS LIGHTNING HEAT EXCHANGER	(L - 26-3/8") X (W - 3") X (H - 8-7/8")*	80249N	80249NB
DOUBLE PASS LIGHTNING HEAT EXCHANGER W/ FAN KIT**	(L - 26-3/8") X (W - 5-3/8") X (H - 8-7/8")*	80249N-FS	80249N-FSB
LIGHTNING HEAT EXCHANGER FAN KIT ONLY	(L - 22-11/32") X (W - 2-5/32") X (H - 8-7/8")*	80249NFAN***	80249NFANB***

*OUTSIDE DIMENSIONS TANK TO TANK, TOP TO BOTTOM & FRONT TO BACK OF CORE.

**WIDTH MEASUREMENTS INCLUDE FAN WIDTH.

***FAN KIT IS NOT COMPATIBLE WITH STANDARD STYLE 80245N.



'10 - '14 SUPERCHARGED F-150/RAPTOR HEAT EXCHANGERS

The 80284 is over 3 times thicker than competitor heat exchangers. The 80284 offers increased surface area, volume, and a double pass design (uses a baffle to pass the coolant through the core twice) to help reduce coolant temperatures by as much as 30°F. The 80284PRO comes with the dual fans which adds over 1600 CFM of constant airflow (800 CFM per fan) to reduce heat soak when there is reduced air flow through the heat exchanger. The heat exchanger can be installed in approximately 1 hour. These heat exchangers will fit Roush or Whipple supercharger kits. Whipple installations require extra mounting brackets. There is no drilling, cutting, or fabrication required. Detailed instructions included.

2010 & UP SUPERCHARGED F-150 / RAPTOR	DIMENSIONS	SATIN FINISH	BLACK FINISH
DOUBLE PASS F150/RAPTOR HEAT EXCHANGER	(L - 26") X (W - 3") X (H - 15-3/32")*	80284NDP	80284NDPB
DOUBLE PASS F150/RAPTOR HEAT EXCHANGER W/ FAN KIT	(L - 26") X (W - 5") X (H - 15-3/32")*	80284PRO	80284PROB
WHIPPLE MOUNTING BRACKET KIT		80284WHIPPLE	

*OUTSIDE DIMENSIONS TANK TO TANK, TOP TO BOTTOM & FRONT TO BACK OF CORE.

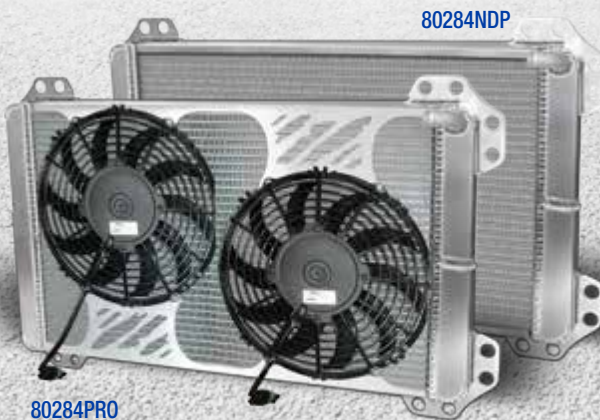

'10-'15 SS & '12-'15 ZL1 CAMARO HEAT EXCHANGERS

AFCO's NEW Camaro heat exchanger is a double pass design with 350% more cooling area than stock. It is available with or without 10" SPAL fans and fits the '12-'15 ZL1 Camaro & '10-'15 Camaro SS with aftermarket supercharger. There is no cutting or fabrication required. Two holes must be drilled for installation.

APPLICATIONS	DIMENSIONS	PART #
ZL1 HEAT EXCHANGER W/O FANS	(L - 26-1/4") X (W - 3") X (H - 11-1/8")*	80283NDP
ZL1 HEAT EXCHANGER W/O FANS - BLACK	(L - 26-1/4") X (W - 3") X (H - 11-1/8")*	80283NDPB
ZL1 HEAT EXCHANGER W/ FANS	(L - 26-1/4") X (W - 2-5/16") X (H - 11-3/8")*	80283PRO
ZL1 HEAT EXCHANGER W/ FANS - BLACK	(L - 26-1/4") X (W - 2-5/16") X (H - 11-3/8")*	80283PROB

*OUTSIDE DIMENSIONS TANK TO TANK, TOP TO BOTTOM & FRONT TO BACK OF CORE. FAN WIDTH MEASURES 2-1/16".

- Double pass design.
- **350% more cooling area than stock.**
- Dual 10" SPAL fans with wiring harness and relay.
- Also fits '10-'15 Camaro SS with aftermarket supercharger.
- All hardware and detailed instructions included.
- Available with an optional black "Thermal Coating" finish for improved cooling.

NEW!

80283PROB



80283PRO



'09-'15 CADILLAC CTS-V HEAT EXCHANGERS

AFCO's NEW Cadillac CTS-V heat exchanger is an all-aluminum, double pass design that lowers coolant temperature by 20° F. It is a direct fit heat exchanger and it installs in approximately 2 hours. There is no drilling, cutting, or fabrication required.

APPLICATIONS	DIMENSIONS	PART #
CADILLAC CTS-V HEAT EXCHANGER	(L - 21") X (W - 2-1/16") X (H - 15")*	80293NDP
CADILLAC CTS-V HEAT EXCHANGER - BLACK	(L - 21") X (W - 2-1/16") X (H - 15")*	80293NDPB

*OUTSIDE DIMENSIONS TANK TO TANK, TOP TO BOTTOM & FRONT TO BACK OF CORE.

- Single row 1-1/2" core vs OEM single row 5/8" core, 2.4 times thicker than OEM.
- Double pass design for maximum temperature drop and to utilize entire core (OEM was single pass).
- Maintains a lower and more consistent heat exchanger coolant temperature after a WOT run.
- Expect as much as 20° F drop in coolant temperature.
- All aluminum TIG-welded construction.
- All hardware and detailed installation instructions included.
- Available with an optional black "Thermal Coating" finish for improved cooling.

NEW!

80293NDPB



80293NDP



C7 Z06 CORVETTE HEAT EXCHANGERS

AFCO's C7 Z06 Corvette heat exchanger is an all-aluminum, double pass design that lowers coolant temperature by 20° F. It is a direct-fit heat exchanger and it installs in approximately 3-5 hours. There is no drilling, cutting, or fabrication required.

APPLICATIONS	DIMENSIONS	PART #
C7 Z06 CORVETTE HEAT EXCHANGER W/O FANS	(L - 22") X (W - 3") X (H - 9-9/16")*	80294NDP
C7 Z06 CORVETTE HEAT EXCHANGER W/O FANS - BLACK	(L - 22") X (W - 3") X (H - 9-9/16")*	80294NDPB

*OUTSIDE DIMENSIONS TANK TO TANK, TOP TO BOTTOM & FRONT TO BACK OF CORE.

- Dual row 1.00" core vs. single row 1.38" on OEM unit.
- Double pass design for maximum temperature drop.
- Expect as much as 20° F drop in coolant temperature.
- All aluminum TIG-welded construction.
- Installation time approximately 3-5 hours.
- Available with an optional black "Thermal Coating" finish for improved cooling.
- All hardware and detailed installation instructions included.



MUSCLE CAR COOLING

DIRECT FIT RADIATORS

- Perfect, bolt-in direct fit.
- 100% aluminum - NO EPOXY.
- Billet filler neck w/ threaded, high capacity overflow tube.
- High performance, dual one inch tubes.
- TIG-welded, laser-cut tanks.
- LS based engine conversions.
- 100% pressure tested.
- Cross flow design.
- OEM size inlets/outlets & petcocks.
- Auto trans fittings in factory location.
- Optional full, show-quality polish or black thermal coating.
- Full 1 year warranty.

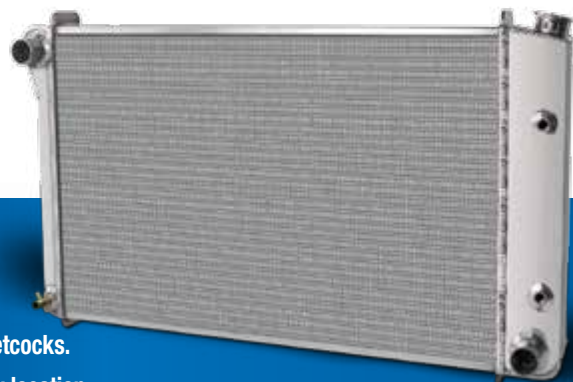

HOW TO BUILD YOUR PART NUMBER

1 PICK YOUR RADIATOR...

Part #
80251
BASE NUMBER



Example: **80251-S-NA-N**

2



- **S** (Satin: Std.)
- **P** (Polished:)
- **B** (Black:)

FINISH CHOICES

3



- **NA** (No Fan & Shroud: Std.)
- **SS** (Single Satin)
- **SP** (Single Polished)
- **SB** (Single Black)
- **DS** (Dual Fan Satin)
- **DP** (Dual Fan Polished)
- **DB** (Dual Fan Black)

ELECTRIC FAN & SHROUD CHOICES

4

WITH OR
WITHOUT BUILT-IN
TRANSMISSION
COOLER

- **N** (No Trans. Cooler: Std.)
- **Y** (w/ Trans. Cooler:)

BUILT-IN TRANS. COOLER

NEED A CUSTOM RADIATOR? SEE PAGE 105.



MUSCLE CAR COOLING

'67-'69 CAMARO



BUILD YOUR PART NUMBER...
Example: 80250-S-NA-N

- 80250 26"(w) x 18-3/8"(h)
- 80251 28"(w) x 18-3/8"(h)
- 84251 LS Conv. (Double Pass)
28"(w) x 17-3/4"(h)*

BASE NUMBER



- **S** (Satin: Std.)
- **P** (Polished)
- **B** (Black)
- **F** (Fan & Shroud Only)

FINISH CHOICES



- **NA** (No Fan & Shroud: Std.)
- **SS** (Single Satin)
- **SP** (Single Polished)
- **SB** (Single Black)
- **DS** (Dual Fan Satin)
- **DP** (Dual Fan Polished)
- **DB** (Dual Fan Black)

ELECTRIC FAN & SHROUD CHOICES

See page 115 for wire harness options.



WITH OR WITHOUT BUILT-IN TRANSMISSION COOLER

- **N** (No Trans. Cooler: Std.)
- **Y** (w/ Trans. Cooler)

BUILT-IN TRANS. COOLER

'70-'81 CAMARO



BUILD YOUR PART NUMBER...
Example: 80255-S-NA-N

- 80255 31-1/4"(w) x 17-1/4"(h)
- 84255 LS Conv. (Double Pass)
31-1/8"(w) x 17-3/4"(h)*

BASE NUMBER



- **S** (Satin: Std.)
- **P** (Polished)
- **B** (Black)
- **F** (Fan & Shroud Only)

FINISH CHOICES



- **NA** (No Fan & Shroud: Std.)
- **SS** (Single Satin)
- **SP** (Single Polished)
- **SB** (Single Black)
- **DS** (Dual Fan Satin)
- **DP** (Dual Fan Polished)
- **DB** (Dual Fan Black)

ELECTRIC FAN & SHROUD CHOICES

See page 115 for wire harness options.



WITH OR WITHOUT BUILT-IN TRANSMISSION COOLER

- **N** (No Trans. Cooler: Std.)
- **Y** (w/ Trans. Cooler)

BUILT-IN TRANS. COOLER

* NOT SHOWN

MUSCLE CAR COOLING

'70-'81 FIREBIRD/TA



- **S** (Satin: Std.)
- **P** (Polished)
- **B** (Black)
- **F** (Fan & Shroud Only)

FINISH CHOICES



- **NA** (No Fan & Shroud: Std.)
- **SS** (Single Satin)
- **SP** (Single Polished)
- **SB** (Single Black)
- **DS** (Dual Fan Satin)
- **DP** (Dual Fan Polished)
- **DB** (Dual Fan Black)

ELECTRIC FAN & SHROUD CHOICES

See page 115 for wire harness options.



WITH OR WITHOUT BUILT-IN TRANSMISSION COOLER

- **N** (No Trans. Cooler: Std.)
- **Y** (w/ Trans. Cooler)

BUILT-IN TRANS. COOLER

**BUILD YOUR PART NUMBER...
Example: 80290-S-NA-N**

80290 32-1/4"(w) x 17-1/4"(h)
84290 LS Conv. (Double Pass)
32-1/4"(w) x 17-1/4"(h)*

BASE NUMBER

'82-'92 CAMARO Z28/IROC - (V8 OEM 26-3/8" CORE)



- **S** (Satin: Std.)
- **P** (Polished)
- **B** (Black)
- **F** (Fan & Shroud Only)

FINISH CHOICES



- **NA** (No Fan & Shroud: Std.)
- **SS** (Single Satin)
- **SP** (Single Polished)
- **SB** (Single Black)
- **DS** (Dual Fan Satin)
- **DP** (Dual Fan Polished)
- **DB** (Dual Fan Black)

ELECTRIC FAN & SHROUD CHOICES

See page 115 for wire harness options.



WITH OR WITHOUT BUILT-IN TRANSMISSION COOLER

- **N** (No Trans. Cooler: Std.)
- **Y** (w/ Trans. Cooler)

BUILT-IN TRANS. COOLER

**BUILD YOUR PART NUMBER...
Example: 80257-S-NA-N**

80257 30-1/2"(w) x 17-1/2"(h)
84257 30"(w) x 17-3/4"(h)*

BASE NUMBER

* NOT SHOWN

MUSCLE CAR COOLING

'66-'67 CHEVELLE



BUILD YOUR PART NUMBER...
Example: 80252-S-NA-N

- 80252** 25"(w) x 21-3/8"(h)
OEM Style Vertical
- 84252** LS Conv. (Double Pass)
25-1/4"(w) x 19-1/2"(h)*

BASE NUMBER



- **S** (Satin: Std.)
- **P** (Polished)
- **B** (Black)
- **F** (Fan & Shroud Only)

FINISH CHOICES

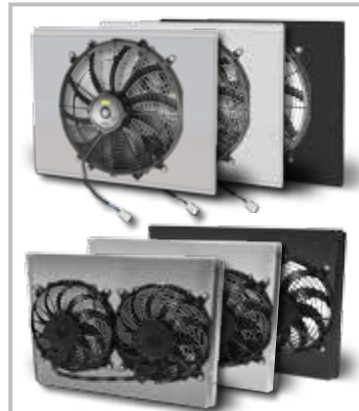

- **NA** (No Fan & Shroud: Std.)
- **SS** (Single Satin)
- **SP** (Single Polished)
- **SB** (Single Black)
- **DS** (Dual Fan Satin)
- **DP** (Dual Fan Polished)
- **DB** (Dual Fan Black)

ELECTRIC FAN & SHROUD CHOICES

See page 115 for wire harness options.



WITH OR WITHOUT BUILT-IN TRANSMISSION COOLER

- **N** (No Trans. Cooler: Std.)
- **Y** (w/ Trans. Cooler)

BUILT-IN TRANS. COOLER

'68-'77 CHEVELLE



BUILD YOUR PART NUMBER...
Example: 80253-S-NA-N

- 80253** 34-1/4"(w) x 17-3/4"(h)
- 84253** LS Conv. (Double Pass)
32-1/2"(w) x 17-3/4"(h)*

BASE NUMBER



- **S** (Satin: Std.)
- **P** (Polished)
- **B** (Black)
- **F** (Fan & Shroud Only)

FINISH CHOICES



- **NA** (No Fan & Shroud: Std.)
- **SS** (Single Satin)
- **SP** (Single Polished)
- **SB** (Single Black)
- **DS** (Dual Fan Satin)
- **DP** (Dual Fan Polished)
- **DB** (Dual Fan Black)

ELECTRIC FAN & SHROUD CHOICES

See page 115 for wire harness options.



WITH OR WITHOUT BUILT-IN TRANSMISSION COOLER

- **N** (No Trans. Cooler: Std.)
- **Y** (w/ Trans. Cooler)

BUILT-IN TRANS. COOLER

* NOT SHOWN

MUSCLE CAR COOLING

'62-'67 NOVA



**BUILD YOUR PART NUMBER...
Example: 80285-S-NA-N**

23-1/2" Core Support	80285	22-1/4"(w) x 20-1/8"(h)*
23-1/2" Core Support	84285	22-1/4"(w) x 20-1/8"(h) LS Conversion*
	80286	23-1/4"(w) x 20-1/4"(h) OEM Style Vertical
24-1/2" Core Support	80287	23-1/4"(w) x 20"(h)
24-1/2" Core Support	84287	LS Conv. (Double Pass) 23-1/4"(w) x 20"(h)*

BASE NUMBER



80286



80287

- **S** (Satin: Std.)
- **P** (Polished)
- **B** (Black)
- **F** (Fan & Shroud Only)

FINISH CHOICES



- **NA** (No Fan & Shroud: Std.)
- **SS** (Single Satin)
- **SP** (Single Polished)
- **SB** (Single Black)
- **DS** (Dual Fan Satin)
- **DP** (Dual Fan Polished)
- **DB** (Dual Fan Black)

ELECTRIC FAN & SHROUD CHOICES

See page 115 for wire harness options.



WITH OR WITHOUT BUILT-IN TRANSMISSION COOLER

- **N** (No Trans. Cooler: Std.)
- **Y** (w/ Trans. Cooler)

BUILT-IN TRANS. COOLER

'68-'74 NOVA



**BUILD YOUR PART NUMBER...
Example: 80288-S-NA-N**

'68-'74 SBC 20" Core Support	80288	25-1/2"(w) x 17-3/4"(h)
'72-'74 SBC 22-3/8" Core Support	80289	28"(w) x 17-3/4"(h)
'68-'72 BBC 22-3/8" Core Support	80289	28"(w) x 17-3/4"(h)

BASE NUMBER



- **S** (Satin: Std.)
- **P** (Polished)
- **B** (Black)
- **F** (Fan & Shroud Only)

FINISH CHOICES



- **NA** (No Fan & Shroud: Std.)
- **SS** (Single Satin)
- **SP** (Single Polished)
- **SB** (Single Black)
- **DS** (Dual Fan Satin)
- **DP** (Dual Fan Polished)
- **DB** (Dual Fan Black)

ELECTRIC FAN & SHROUD CHOICES

See page 115 for wire harness options.



WITH OR WITHOUT BUILT-IN TRANSMISSION COOLER

- **N** (No Trans. Cooler: Std.)
- **Y** (w/ Trans. Cooler)

BUILT-IN TRANS. COOLER

* NOT SHOWN

MUSCLE CAR COOLING

'75-'79 NOVA



BUILD YOUR PART NUMBER...
Example: 80255-S-NA-N

80255 31-1/4"(w) x 17-1/4"(h)
 84255 LS Conv. (Double Pass)
 31-1/8"(w) x 17-3/4"(h)*

BASE NUMBER



- **S** (Satin: Std.)
- **P** (Polished)
- **B** (Black)
- **F** (Fan & Shroud Only)

FINISH CHOICES



- **NA** (No Fan & Shroud: Std.)
- **SS** (Single Satin)
- **SP** (Single Polished)
- **SB** (Single Black)
- **DS** (Dual Fan Satin)
- **DP** (Dual Fan Polished)
- **DB** (Dual Fan Black)

ELECTRIC FAN & SHROUD CHOICES

See page 115 for wire harness options.



WITH OR WITHOUT BUILT-IN TRANSMISSION COOLER

- **N** (No Trans. Cooler: Std.)
- **Y** (w/ Trans. Cooler)

BUILT-IN TRANS. COOLER

'70-'77 MONTE CARLO



BUILD YOUR PART NUMBER...
Example: 80253-S-NA-N

STARTING AT
\$574⁹⁹

80253 34-1/4"(w) x 17-3/4"(h)
 84253 LS Conv. (Double Pass)
 32-1/2"(w) x 17-3/4"(h)*

BASE NUMBER



- **S** (Satin: Std.)
- **P** (Polished)
- **B** (Black)
- **F** (Fan & Shroud Only)

FINISH CHOICES



- **NA** (No Fan & Shroud: Std.)
- **SS** (Single Satin)
- **SP** (Single Polished)
- **SB** (Single Black)
- **DS** (Dual Fan Satin)
- **DP** (Dual Fan Polished)
- **DB** (Dual Fan Black)

ELECTRIC FAN & SHROUD CHOICES

See page 115 for wire harness options.



WITH OR WITHOUT BUILT-IN TRANSMISSION COOLER

- **N** (No Trans. Cooler: Std.)
- **Y** (w/ Trans. Cooler)

BUILT-IN TRANS. COOLER

* NOT SHOWN

MUSCLE CAR COOLING

'78-'88 MONTE CARLO V8/SS



BUILD YOUR PART NUMBER...
Example: 80258-S-NA-N

80258 30-1/2"(w) x 17-1/4"(h)
 84258 LS Conv. (Double Pass)
 29-1/2"(w) x 17-3/4"(h)*

BASE NUMBER



- **S** (Satin: Std.)
- **P** (Polished)
- **B** (Black)
- **F** (Fan & Shroud Only)

FINISH CHOICES



- **NA** (No Fan & Shroud: Std.)
- **SS** (Single Satin)
- **SP** (Single Polished)
- **SB** (Single Black)
- **DS** (Dual Fan Satin)
- **DP** (Dual Fan Polished)
- **DB** (Dual Fan Black)

ELECTRIC FAN & SHROUD CHOICES

See page 115 for wire harness options.



WITH OR WITHOUT BUILT-IN TRANSMISSION COOLER

- **N** (No Trans. Cooler: Std.)
- **Y** (w/ Trans. Cooler)

BUILT-IN TRANS. COOLER

'73-'76 CORVETTE



BUILD YOUR PART NUMBER...
Example: 80265-S-NA-N

80265 31-1/2"(w) x 17-3/4"(h)

BASE NUMBER



- **S** (Satin: Std.)
- **P** (Polished)
- **B** (Black)
- **F** (Fan & Shroud Only)

FINISH CHOICES



- **NA** (No Fan & Shroud: Std.)
- **SS** (Single Satin)
- **SP** (Single Polished)
- **SB** (Single Black)
- **DS** (Dual Fan Satin)
- **DP** (Dual Fan Polished)
- **DB** (Dual Fan Black)

ELECTRIC FAN & SHROUD CHOICES

See page 115 for wire harness options.



WITH OR WITHOUT BUILT-IN TRANSMISSION COOLER

- **N** (No Trans. Cooler: Std.)
- **Y** (w/ Trans. Cooler)

BUILT-IN TRANS. COOLER

* NOT SHOWN

MUSCLE CAR COOLING

'71-'79 BELAIR/BISCAYNE IMPALA



- **S** (Satin: Std.)
- **P** (Polished)
- **B** (Black)
- **F** (Fan & Shroud Only)

FINISH CHOICES

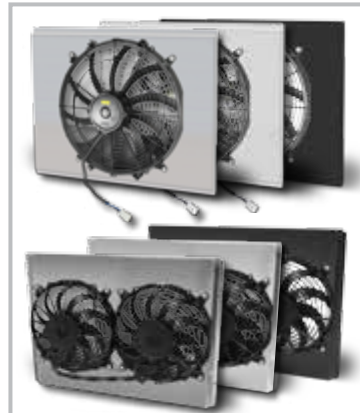

- **NA** (No Fan & Shroud: Std.)
- **SS** (Single Satin)
- **SP** (Single Polished)
- **SB** (Single Black)
- **DS** (Dual Fan Satin)
- **DP** (Dual Fan Polished)
- **DB** (Dual Fan Black)

ELECTRIC FAN & SHROUD CHOICES

See page 115 for wire harness options.



WITH OR WITHOUT BUILT-IN TRANSMISSION COOLER

- **N** (No Trans. Cooler: Std.)
- **Y** (w/ Trans. Cooler)

BUILT-IN TRANS. COOLER

**BUILD YOUR PART NUMBER...
Example: 80253-S-NA-N**

STARTING AT
\$574⁹⁹

80253 34-1/4"(w) x 17-3/4"(h)
84253 LS Conv. (Double Pass)
32-1/2"(w) x 17-3/4"(h)*

BASE NUMBER

'80-'86 IMPALA/CAPRICE



- **S** (Satin: Std.)
- **P** (Polished)
- **B** (Black)
- **F** (Fan & Shroud Only)

FINISH CHOICES



- **NA** (No Fan & Shroud: Std.)
- **SS** (Single Satin)
- **SP** (Single Polished)
- **SB** (Single Black)
- **DS** (Dual Fan Satin)
- **DP** (Dual Fan Polished)
- **DB** (Dual Fan Black)

ELECTRIC FAN & SHROUD CHOICES

See page 115 for wire harness options.



WITH OR WITHOUT BUILT-IN TRANSMISSION COOLER

- **N** (No Trans. Cooler: Std.)
- **Y** (w/ Trans. Cooler)

BUILT-IN TRANS. COOLER

**BUILD YOUR PART NUMBER...
Example: 80258-S-NA-N**

80258 30-1/2"(w) x 17-1/4"(h)
84258 LS Conv. (Double Pass)
29-1/2"(w) x 17-3/4"(h)*

BASE NUMBER

* NOT SHOWN

MUSCLE CAR COOLING

'69-'73 SKYLARK/GS/GSX



- **S** (Satin: Std.)
- **P** (Polished)
- **B** (Black)
- **F** (Fan & Shroud Only)

FINISH CHOICES



- **NA** (No Fan & Shroud: Std.)
- **SS** (Single Satin)
- **SP** (Single Polished)
- **SB** (Single Black)
- **DS** (Dual Fan Satin)
- **DP** (Dual Fan Polished)
- **DB** (Dual Fan Black)

ELECTRIC FAN & SHROUD CHOICES

See page 115 for wire harness options.



WITH OR WITHOUT BUILT-IN TRANSMISSION COOLER

- **N** (No Trans. Cooler: Std.)
- **Y** (w/ Trans. Cooler)

BUILT-IN TRANS. COOLER

**BUILD YOUR PART NUMBER...
Example: 80253-S-NA-N**

80253 34-1/4"(w) x 17-3/4"(h)
84253 LS Conv. (Double Pass)
32-1/2"(w) x 17-3/4"(h)*

BASE NUMBER

'75-'79 SKYLARK/GS/GSX



- **S** (Satin: Std.)
- **P** (Polished)
- **B** (Black)
- **F** (Fan & Shroud Only)

FINISH CHOICES



- **NA** (No Fan & Shroud: Std.)
- **SS** (Single Satin)
- **SP** (Single Polished)
- **SB** (Single Black)
- **DS** (Dual Fan Satin)
- **DP** (Dual Fan Polished)
- **DB** (Dual Fan Black)

ELECTRIC FAN & SHROUD CHOICES

See page 115 for wire harness options.



WITH OR WITHOUT BUILT-IN TRANSMISSION COOLER

- **N** (No Trans. Cooler: Std.)
- **Y** (w/ Trans. Cooler)

BUILT-IN TRANS. COOLER

**BUILD YOUR PART NUMBER...
Example: 80255-S-NA-N**

80255 31-1/4"(w) x 17-1/4"(h)
84255 LS Conv. (Double Pass)
31-1/8"(w) x 17-3/4"(h)*

BASE NUMBER

* NOT SHOWN

MUSCLE CAR COOLING

'73-'77 REGAL/GRAND SPORT



BUILD YOUR PART NUMBER...
Example: 80253-S-NA-N

80253 34-1/4"(w) x 17-3/4"(h)
 84253 LS Conv. (Double Pass)
 32-1/2"(w) x 17-3/4"(h)*

BASE NUMBER



- **S** (Satin: Std.)
- **P** (Polished)
- **B** (Black)
- **F** (Fan & Shroud Only)

FINISH CHOICES



- **NA** (No Fan & Shroud: Std.)
- **SS** (Single Satin)
- **SP** (Single Polished)
- **SB** (Single Black)
- **DS** (Dual Fan Satin)
- **DP** (Dual Fan Polished)
- **DB** (Dual Fan Black)

ELECTRIC FAN & SHROUD CHOICES

See page 115 for wire harness options.



WITH OR WITHOUT BUILT-IN TRANSMISSION COOLER

- **N** (No Trans. Cooler: Std.)
- **Y** (w/ Trans. Cooler)

BUILT-IN TRANS. COOLER

'78-'87 REGAL/GRAND NATIONAL/GNX



BUILD YOUR PART NUMBER...
Example: 80258-S-NA-N

80258 30-1/4"(w) x 17-1/4"(h)
 84258 LS Conv. (Double Pass)
 29-1/2"(w) x 17-3/4"(h)*

BASE NUMBER



- **S** (Satin: Std.)
- **P** (Polished)
- **B** (Black)
- **F** (Fan & Shroud Only)

FINISH CHOICES



- **NA** (No Fan & Shroud: Std.)
- **SS** (Single Satin)
- **SP** (Single Polished)
- **SB** (Single Black)
- **DS** (Dual Fan Satin)
- **DP** (Dual Fan Polished)
- **DB** (Dual Fan Black)

ELECTRIC FAN & SHROUD CHOICES

See page 115 for wire harness options.



WITH OR WITHOUT BUILT-IN TRANSMISSION COOLER

- **N** (No Trans. Cooler: Std.)
- **Y** (w/ Trans. Cooler)

BUILT-IN TRANS. COOLER

* NOT SHOWN

MUSCLE CAR COOLING

'66-'77 CUTLASS/442/HURST OLDS



BUILD YOUR PART NUMBER...
Example: 80253-S-NA-N

80253 34-1/4"(w) x 17-3/4"(h)
 84253 LS Conv. (Double Pass)
 32-1/2"(w) x 17-3/4"(h)*

BASE NUMBER



- **S** (Satin: Std.)
- **P** (Polished)
- **B** (Black)
- **F** (Fan & Shroud Only)

FINISH CHOICES



- **NA** (No Fan & Shroud: Std.)
- **SS** (Single Satin)
- **SP** (Single Polished)
- **SB** (Single Black)
- **DS** (Dual Fan Satin)
- **DP** (Dual Fan Polished)
- **DB** (Dual Fan Black)

ELECTRIC FAN & SHROUD CHOICES

See page 115 for wire harness options.



WITH OR WITHOUT BUILT-IN TRANSMISSION COOLER

- **N** (No Trans. Cooler: Std.)
- **Y** (w/ Trans. Cooler)

BUILT-IN TRANS. COOLER

'78-'88 CUTLASS/442/HURST OLDS



BUILD YOUR PART NUMBER...
Example: 80258-S-NA-N

80258 30-1/2"(w) x 17-1/4"(h)
 84258 LS Conv. (Double Pass)
 29-1/2"(w) x 17-3/4"(h)*

BASE NUMBER



- **S** (Satin: Std.)
- **P** (Polished)
- **B** (Black)
- **F** (Fan & Shroud Only)

FINISH CHOICES



- **NA** (No Fan & Shroud: Std.)
- **SS** (Single Satin)
- **SP** (Single Polished)
- **SB** (Single Black)
- **DS** (Dual Fan Satin)
- **DP** (Dual Fan Polished)
- **DB** (Dual Fan Black)

ELECTRIC FAN & SHROUD CHOICES

See page 115 for wire harness options.



WITH OR WITHOUT BUILT-IN TRANSMISSION COOLER

- **N** (No Trans. Cooler: Std.)
- **Y** (w/ Trans. Cooler)

BUILT-IN TRANS. COOLER

* NOT SHOWN

MUSCLE CAR COOLING

'64-'67 GTO



See page 115 for wire harness options.



BUILD YOUR PART NUMBER...
Example: 80298-S-NA-N

80298 25"(w) x 19-1/2"(h)
 84298 LS Conv. (Double Pass)
 25"(w) x 19-1/2"(h)*

BASE NUMBER

- **S** (Satin: Std.)
- **P** (Polished)
- **B** (Black)
- **F** (Fan & Shroud Only)

FINISH CHOICES

- **NA** (No Fan & Shroud: Std.)
- **SS** (Single Satin)
- **SP** (Single Polished)
- **SB** (Single Black)
- **DS** (Dual Fan Satin)
- **DP** (Dual Fan Polished)
- **DB** (Dual Fan Black)

ELECTRIC FAN & SHROUD CHOICES

WITH OR WITHOUT BUILT-IN TRANSMISSION COOLER

- **N** (No Trans. Cooler: Std.)
- **Y** (w/ Trans. Cooler)

BUILT-IN TRANS. COOLER

'68-'74 GTO/LEMANS



See page 115 for wire harness options.



BUILD YOUR PART NUMBER...
Example: 80253-S-NA-N

80253 34-1/4"(w) x 17-3/4"(h)
 84253 LS Conv. (Double Pass)
 32-1/2"(w) x 17-3/4"(h)*

BASE NUMBER

- **S** (Satin: Std.)
- **P** (Polished)
- **B** (Black)
- **F** (Fan & Shroud Only)

FINISH CHOICES

- **NA** (No Fan & Shroud: Std.)
- **SS** (Single Satin)
- **SP** (Single Polished)
- **SB** (Single Black)
- **DS** (Dual Fan Satin)
- **DP** (Dual Fan Polished)
- **DB** (Dual Fan Black)

ELECTRIC FAN & SHROUD CHOICES

WITH OR WITHOUT BUILT-IN TRANSMISSION COOLER

- **N** (No Trans. Cooler: Std.)
- **Y** (w/ Trans. Cooler)

BUILT-IN TRANS. COOLER

* NOT SHOWN

MUSCLE CAR COOLING

'72-'77 GRAND PRIX



- **S** (Satin: Std.)
- **P** (Polished)
- **B** (Black)
- **F** (Fan & Shroud Only)

FINISH CHOICES



- **NA** (No Fan & Shroud: Std.)
- **SS** (Single Satin)
- **SP** (Single Polished)
- **SB** (Single Black)
- **DS** (Dual Fan Satin)
- **DP** (Dual Fan Polished)
- **DB** (Dual Fan Black)

ELECTRIC FAN & SHROUD CHOICES

See page 115 for wire harness options.



WITH OR WITHOUT BUILT-IN TRANSMISSION COOLER

- **N** (No Trans. Cooler: Std.)
- **Y** (w/ Trans. Cooler)

BUILT-IN TRANS. COOLER

**BUILD YOUR PART NUMBER...
Example: 80253-S-NA-N**

80253 34-1/4"(w) x 17-3/4"(h)
84253 LS Conv. (Double Pass)
32-1/2"(w) x 17-3/4"(h)*

BASE NUMBER

'78-'87 GRAND PRIX



- **S** (Satin: Std.)
- **P** (Polished)
- **B** (Black)
- **F** (Fan & Shroud Only)

FINISH CHOICES



- **NA** (No Fan & Shroud: Std.)
- **SS** (Single Satin)
- **SP** (Single Polished)
- **SB** (Single Black)
- **DS** (Dual Fan Satin)
- **DP** (Dual Fan Polished)
- **DB** (Dual Fan Black)

ELECTRIC FAN & SHROUD CHOICES

See page 115 for wire harness options.



WITH OR WITHOUT BUILT-IN TRANSMISSION COOLER

- **N** (No Trans. Cooler: Std.)
- **Y** (w/ Trans. Cooler)

BUILT-IN TRANS. COOLER

**BUILD YOUR PART NUMBER...
Example: 80258-S-NA-N**

80258 30-1/2"(w) x 17-1/4"(h)
84258 LS Conv. (Double Pass)
29-1/2"(w) x 17-3/4"(h)*

BASE NUMBER

* NOT SHOWN

MUSCLE CAR COOLING

'67-'77 LEMANS



- **S** (Satin: Std.)
- **P** (Polished)
- **B** (Black)
- **F** (Fan & Shroud Only)

FINISH CHOICES

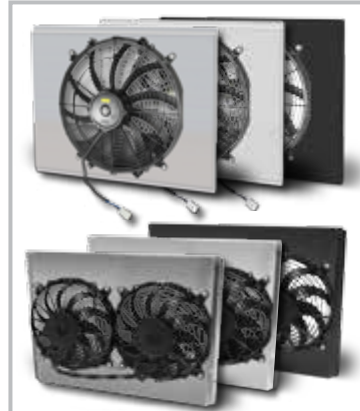

- **NA** (No Fan & Shroud: Std.)
- **SS** (Single Satin)
- **SP** (Single Polished)
- **SB** (Single Black)
- **DS** (Dual Fan Satin)
- **DP** (Dual Fan Polished)
- **DB** (Dual Fan Black)

ELECTRIC FAN & SHROUD CHOICES

See page 115 for wire harness options.



WITH OR WITHOUT BUILT-IN TRANSMISSION COOLER

- **N** (No Trans. Cooler: Std.)
- **Y** (w/ Trans. Cooler)

BUILT-IN TRANS. COOLER

**BUILD YOUR PART NUMBER...
Example: 80253-S-NA-N**

80253 34-1/4"(w) x 17-3/4"(h)
84253 LS Conv. (Double Pass)
32-1/2"(w) x 17-3/4"(h)*

BASE NUMBER

'78-'81 LEMANS V8



- **S** (Satin: Std.)
- **P** (Polished)
- **B** (Black)
- **F** (Fan & Shroud Only)

FINISH CHOICES



- **NA** (No Fan & Shroud: Std.)
- **SS** (Single Satin)
- **SP** (Single Polished)
- **SB** (Single Black)
- **DS** (Dual Fan Satin)
- **DP** (Dual Fan Polished)
- **DB** (Dual Fan Black)

ELECTRIC FAN & SHROUD CHOICES

See page 115 for wire harness options.



WITH OR WITHOUT BUILT-IN TRANSMISSION COOLER

- **N** (No Trans. Cooler: Std.)
- **Y** (w/ Trans. Cooler)

BUILT-IN TRANS. COOLER

**BUILD YOUR PART NUMBER...
Example: 80258-S-NA-N**

80258 30-1/2"(w) x 17-1/4"(h)
84258 LS Conv. (Double Pass)
29-1/2"(w) x 17-3/4"(h)*

BASE NUMBER

* NOT SHOWN

MUSCLE CAR COOLING

'68-'73 TEMPEST/T37



BUILD YOUR PART NUMBER...
Example: 80253-S-NA-N

80253 34-1/4"(w) x 17-3/4"(h)
 84253 LS Conv. (Double Pass)
 32-1/2"(w) x 17-3/4"(h)*

BASE NUMBER



- **S** (Satin: Std.)
- **P** (Polished)
- **B** (Black)
- **F** (Fan & Shroud Only)

FINISH CHOICES



- **NA** (No Fan & Shroud: Std.)
- **SS** (Single Satin)
- **SP** (Single Polished)
- **SB** (Single Black)
- **DS** (Dual Fan Satin)
- **DP** (Dual Fan Polished)
- **DB** (Dual Fan Black)

ELECTRIC FAN & SHROUD CHOICES

See page 115 for wire harness options.



WITH OR WITHOUT BUILT-IN TRANSMISSION COOLER

- **N** (No Trans. Cooler: Std.)
- **Y** (w/ Trans. Cooler)

BUILT-IN TRANS. COOLER

'67-'72 GM TRUCK

LS Conversion Radiator Available!



BUILD YOUR PART NUMBER...
Example: 80243-S-NA-N

80243 33"(w) x 16-7/8"(h)
 84243 LS Conv. (Double Pass)
 32-1/2"(w) x 16-7/8"(h)*

BASE NUMBER



- **S** (Satin: Std.)
- **P** (Polished)
- **B** (Black)
- **F** (Fan & Shroud Only)

FINISH CHOICES



- **NA** (No Fan & Shroud: Std.)
- **SS** (Single Satin)
- **SP** (Single Polished)
- **SB** (Single Black)
- **DS** (Dual Fan Satin)
- **DP** (Dual Fan Polished)
- **DB** (Dual Fan Black)

ELECTRIC FAN & SHROUD CHOICES

See page 115 for wire harness options.



WITH OR WITHOUT BUILT-IN TRANSMISSION COOLER

- **N** (No Trans. Cooler: Std.)
- **Y** (w/ Trans. Cooler)

BUILT-IN TRANS. COOLER

* NOT SHOWN

MUSCLE CAR COOLING

'73-'87 FULL-SIZE GM TRUCK



- **S** (Satin: Std.)
- **P** (Polished)
- **B** (Black)
- **F** (Fan & Shroud Only)

FINISH CHOICES



- **NA** (No Fan & Shroud: Std.)
- **SS** (Single Satin)
- **SP** (Single Polished)
- **SB** (Single Black)
- **DS** (Dual Fan Satin)
- **DP** (Dual Fan Polished)
- **DB** (Dual Fan Black)

ELECTRIC FAN & SHROUD CHOICES

See page 115 for wire harness options.



WITH OR WITHOUT BUILT-IN TRANSMISSION COOLER

- **N** (No Trans. Cooler: Std.)
- **Y** (w/ Trans. Cooler)

BUILT-IN TRANS. COOLER

**BUILD YOUR PART NUMBER...
Example: 80242-S-NA-N**

80242 34-1/8"(w) x 19"(h)
84242 LS Conv. (Double Pass)
34-1/8"(w) x 19"(h)*

BASE NUMBER

'82-'93 S-10 V8 TRUCK



- **S** (Satin: Std.)
- **P** (Polished)
- **B** (Black)
- **F** (Fan & Shroud Only)

FINISH CHOICES

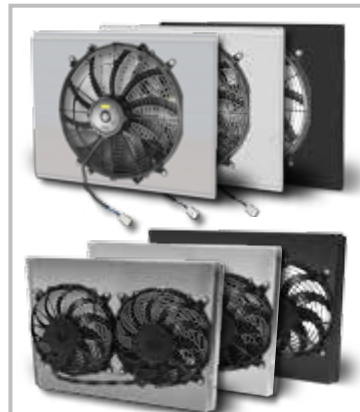

- **NA** (No Fan & Shroud: Std.)
- **SS** (Single Satin)
- **SP** (Single Polished)
- **SB** (Single Black)
- **DS** (Dual Fan Satin)
- **DP** (Dual Fan Polished)
- **DB** (Dual Fan Black)

ELECTRIC FAN & SHROUD CHOICES

See page 115 for wire harness options.



WITH OR WITHOUT BUILT-IN TRANSMISSION COOLER

- **N** (No Trans. Cooler: Std.)
- **Y** (w/ Trans. Cooler)

BUILT-IN TRANS. COOLER

**BUILD YOUR PART NUMBER...
Example: 80240-S-NA-N**

80240 31-3/4"(w) x 16-3/8"(h)

BASE NUMBER

* NOT SHOWN

MUSCLE CAR COOLING

A-BODY MOPAR



BUILD YOUR PART NUMBER...
Example: 83296-S-NA-N

Top Hose - Driver Side	83296 22-1/4"(w) x 22"(h)*
Top Hose - Passenger Side	84296 22-1/4"(w) x 22"(h)*
Top Hose - Driver Side	83295 26-3/8"(w) x 22"(h)*
Top Hose - Passenger Side	84295 26-3/8"(w) x 22"(h)

BASE NUMBER



- **S** (Satin: Std.)
- **P** (Polished)
- **B** (Black)
- **F** (Fan & Shroud Only)

FINISH CHOICES



- **NA** (No Fan & Shroud: Std.)
- **SS** (Single Satin)
- **SP** (Single Polished)
- **SB** (Single Black)
- **DS** (Dual Fan Satin)
- **DP** (Dual Fan Polished)
- **DB** (Dual Fan Black)

ELECTRIC FAN & SHROUD CHOICES

See page 115 for wire harness options.



WITH OR WITHOUT BUILT-IN TRANSMISSION COOLER

- **N** (No Trans. Cooler: Std.)
- **Y** (w/ Trans. Cooler)

BUILT-IN TRANS. COOLER

B & E-BODY MOPAR



BUILD YOUR PART NUMBER...
Example: 83296-S-NA-N

Top Hose - Driver Side	83296 22-1/4"(w) x 22"(h)*
Top Hose - Passenger Side	84296 22-1/4"(w) x 22"(h)*
Top Hose - Driver Side	83295 26-3/8"(w) x 22"(h)*
Top Hose - Passenger Side	84295 26-3/8"(w) x 22"(h)

BASE NUMBER



- **S** (Satin: Std.)
- **P** (Polished)
- **B** (Black)
- **F** (Fan & Shroud Only)

FINISH CHOICES



- **NA** (No Fan & Shroud: Std.)
- **SS** (Single Satin)
- **SP** (Single Polished)
- **SB** (Single Black)
- **DS** (Dual Fan Satin)
- **DP** (Dual Fan Polished)
- **DB** (Dual Fan Black)

ELECTRIC FAN & SHROUD CHOICES

See page 115 for wire harness options.



WITH OR WITHOUT BUILT-IN TRANSMISSION COOLER

- **N** (No Trans. Cooler: Std.)
- **Y** (w/ Trans. Cooler)

BUILT-IN TRANS. COOLER

* NOT SHOWN

MUSCLE CAR COOLING

'63-'65 FALCON/COMET



BUILD YOUR PART NUMBER...
Example: 80276-S-NA-N

Bottom Hose - Passenger **80276** 17"(w) x 19"(h)
 Bottom Hose - Driver Side **81276** 17"(w) x 19"(h)

BASE NUMBER



- **S** (Satin: Std.)
- **P** (Polished)
- **B** (Black)
- **F** (Fan & Shroud Only)

FINISH CHOICES



- **NA** (No Fan & Shroud: Std.)
- **SS** (Single Satin)
- **SP** (Single Polished)
- **SB** (Single Black)

ELECTRIC FAN & SHROUD CHOICES

See page 115 for wire harness options.



WITH OR WITHOUT BUILT-IN TRANSMISSION COOLER

- **N** (No Trans. Cooler: Std.)
- **Y** (w/ Trans. Cooler)

BUILT-IN TRANS. COOLER

'64 1/2 -'66 MUSTANG



BUILD YOUR PART NUMBER...
Example: 80276-S-NA-N

Bottom Hose - Passenger **80276** 17"(w) x 19"(h)
 Bottom Hose - Driver Side **81276** 17"(w) x 19"(h)

BASE NUMBER



- **S** (Satin: Std.)
- **P** (Polished)
- **B** (Black)
- **F** (Fan & Shroud Only)

FINISH CHOICES



- **NA** (No Fan & Shroud: Std.)
- **SS** (Single Satin)
- **SP** (Single Polished)
- **SB** (Single Black)

ELECTRIC FAN & SHROUD CHOICES

See page 115 for wire harness options.



WITH OR WITHOUT BUILT-IN TRANSMISSION COOLER

- **N** (No Trans. Cooler: Std.)
- **Y** (w/ Trans. Cooler)

BUILT-IN TRANS. COOLER

MUSCLE CAR COOLING

'79-'93 & '94-'95 MUSTANG RADIATORS



BUILD YOUR PART NUMBER...
Example: 81271-S-NA-N

81270 28-3/4"(w) x 16-7/8"(h)
 81271 29-1/4"(w) x 16-1/2"(h)

BASE NUMBER



81270



81271

- S (Satin: Std.)
- P (Polished)
- B (Black)
- F (Fan & Shroud Only)

FINISH CHOICES

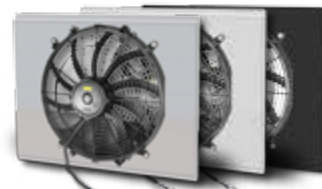

- NA (No Fan & Shroud: Std.)
- SS (Single Satin)
- SP (Single Polished)
- SB (Single Black)
- DS (Dual Fan Satin)
- DP (Dual Fan Polished)
- DB (Dual Fan Black)

ELECTRIC FAN & SHROUD CHOICES

See page 115 for wire harness options.



WITH OR WITHOUT BUILT-IN TRANSMISSION COOLER

- N (No Trans. Cooler: Std.)
- Y (w/ Trans. Cooler)

BUILT-IN TRANS. COOLER

'97-'04 MUSTANG RADIATORS



BUILD YOUR PART NUMBER...
Example: 80291-S-NA-N

80291 29-3/4"(w) x 17-3/4"(h)

BASE NUMBER



- S (Satin: Std.)
- P (Polished)
- B (Black)
- F (Fan & Shroud Only)

FINISH CHOICES



- NA (No Fan & Shroud: Std.)
- SS (Single Satin)
- SP (Single Polished)
- SB (Single Black)
- DS (Dual Fan Satin)
- DP (Dual Fan Polished)
- DB (Dual Fan Black)

ELECTRIC FAN & SHROUD CHOICES

See page 115 for wire harness options.



WITH OR WITHOUT BUILT-IN TRANSMISSION COOLER

- N (No Trans. Cooler: Std.)
- Y (w/ Trans. Cooler)

BUILT-IN TRANS. COOLER

CUSTOM RADIATORS

AFCO Racing Products offers custom built radiators. Base price includes core, tanks, any fin covers, billet filler neck, drain cock, and all inlets/outlets, bungs and fittings. Comes in standard satin finish.

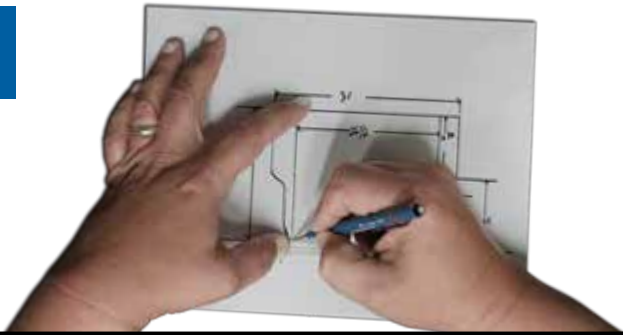

HOW TO BUILD YOUR VERTICAL FLOW RADIATOR

1

Part #
80002



Example: 80002-S-SS-N

2



- S (Satin: Std.)
- P (Polished)
- B (Black)

FINISH CHOICES

3



- NA (No Fan & Shroud: Std.)
- SS (Single Satin)
- SP (Single Polished)
- SB (Single Black)
- DS (Dual Fan Satin)
- DP (Dual Fan Polished)
- DB (Dual Fan Black)

ELECTRIC FAN & SHROUD CHOICES

4

WITH OR
WITHOUT BUILT-IN
TRANSMISSION
COOLER

- N (No Trans. Cooler: Std.)
- Y (w/ Trans. Cooler)

BUILT-IN TRANS. COOLER

HOW TO BUILD YOUR CROSS FLOW RADIATOR

1

Part #
80003



Example: 80003-S-SS-N

2



- S (Satin: Std.)
- P (Polished)
- B (Black)

FINISH CHOICES

3



- NA (No Fan & Shroud: Std.)
- SS (Single Satin)
- SP (Single Polished)
- SB (Single Black)
- DS (Dual Fan Satin)
- DP (Dual Fan Polished)
- DB (Dual Fan Black)

ELECTRIC FAN & SHROUD CHOICES

4

WITH OR
WITHOUT BUILT-IN
TRANSMISSION
COOLER

- N (No Trans. Cooler: Std.)
- Y (w/ Trans. Cooler)

BUILT-IN TRANS. COOLER

HOW TO BUILD YOUR DOUBLE PASS CROSS FLOW RADIATOR (inlets & outlets must be on same side as water pump)

1

Part #
80004



Example: 80004-S-SS-N

2

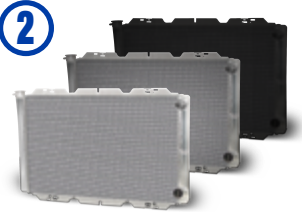

- S (Satin: Std.)
- P (Polished)
- B (Black)

FINISH CHOICES

3



- NA (No Fan & Shroud: Std.)
- SS (Single Satin)
- SP (Single Polished)
- SB (Single Black)
- DS (Dual Fan Satin)
- DP (Dual Fan Polished)
- DB (Dual Fan Black)

ELECTRIC FAN & SHROUD CHOICES

4

WITH OR
WITHOUT BUILT-IN
TRANSMISSION
COOLER

- N (No Trans. Cooler: Std.)
- Y (w/ Trans. Cooler)

BUILT-IN TRANS. COOLER

STREET ROD COOLING

DIRECT FIT RADIATORS

- 100% aluminum - NO EPOXY.
- Billet filler neck w/ threaded, high capacity overflow tube.
- High performance, dual one inch tubes.
- TIG-welded, laser-cut tanks.
- Down flow design.
- 100% pressure tested.
- Auto trans cooler available.
- 1-1/2" inlet and 1-3/4" outlet.
- Full 1 year warranty.
- Optional full, show-quality polish or black thermal coating.



HOW TO BUILD YOUR PART NUMBER

1 PICK YOUR RADIATOR...

Part #
80167
BASE NUMBER



Example: **80167-S-NA-N**

2



- **S** (Satin: Std.)
- **P** (Polished)
- **B** (Black)

FINISH CHOICES

3



- **NA** (No Fan & Shroud: Std.)
- **SS** (Single Satin)
- **SP** (Single Polished)
- **SB** (Single Black)
- **DS** (Dual Fan Satin)
- **DP** (Dual Fan Polished)
- **DB** (Dual Fan Black)

ELECTRIC FAN & SHROUD CHOICES

4

WITH OR
WITHOUT BUILT-IN
TRANSMISSION
COOLER

- **N** (No Trans. Cooler: Std.)
- **Y** (w/ Trans. Cooler)

BUILT-IN TRANS. COOLER

NEED A CUSTOM RADIATOR? SEE PAGE 105.



STREET ROD COOLING

'23 T-BUCKET



BUILD YOUR PART NUMBER... Example: 80167-S-NA-N

80167 18"(w) x 23"(h) - Chevy Engine

BASE NUMBER



- **S** (Satin: Std.)
- **P** (Polished)
- **B** (Black)
- **F** (Fan & Shroud Only)

FINISH CHOICES

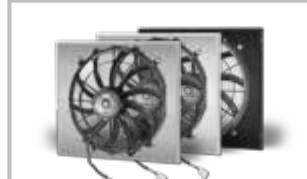

- **NA** (No Fan & Shroud: Std.)
- **SS** (Single Satin)
- **SP** (Single Polished)
- **SB** (Single Black)

ELECTRIC FAN & SHROUD CHOICES

See page 115 for wire harness options.

NOT AVAILABLE WITH BUILT-IN TRANSMISSION COOLER

- **N** (No Trans. Cooler: Std.)

BUILT-IN TRANS. COOLER

'32 FORD



BUILD YOUR PART NUMBER... Example: 80145-S-NA-N

81145 17"(w) x 27"(h) - Ford Engine
80145 17"(w) x 27"(h) - Chevy Engine

BASE NUMBER



- **S** (Satin: Std.)
- **P** (Polished)
- **B** (Black)
- **F** (Fan & Shroud Only)

FINISH CHOICES



- **NA** (No Fan & Shroud: Std.)
- **SS** (Single Satin)
- **SP** (Single Polished)
- **SB** (Single Black)

ELECTRIC FAN & SHROUD CHOICES

See page 115 for wire harness options.

WITH OR WITHOUT BUILT-IN TRANSMISSION COOLER

- **N** (No Trans. Cooler: Std.)
- **Y** (w/ Trans. Cooler)

BUILT-IN TRANS. COOLER

'33-'34 FORD



BUILD YOUR PART NUMBER... Example: 80146-S-NA-N

81146 17"(w) x 27"(h) - Ford Engine
80146 17"(w) x 27"(h) - Chevy Engine

BASE NUMBER



- **S** (Satin: Std.)
- **P** (Polished)
- **B** (Black)
- **F** (Fan & Shroud Only)

FINISH CHOICES



- **NA** (No Fan & Shroud: Std.)
- **SS** (Single Satin)
- **SP** (Single Polished)
- **SB** (Single Black)

ELECTRIC FAN & SHROUD CHOICES

See page 115 for wire harness options.

WITH OR WITHOUT BUILT-IN TRANSMISSION COOLER

- **N** (No Trans. Cooler: Std.)
- **Y** (w/ Trans. Cooler)

BUILT-IN TRANS. COOLER

STREET ROD COOLING

'35 FORD



See page 115 for wire harness options.

BUILD YOUR PART NUMBER... Example: 80148-S-NA-N

- **S** (Satin: Std.)
- **P** (Polished)
- **B** (Black)
- **F** (Fan & Shroud Only)

- **NA** (No Fan & Shroud: Std.)
- **SS** (Single Satin)
- **SP** (Single Polished)
- **SB** (Single Black)

NOT AVAILABLE WITH BUILT-IN TRANSMISSION COOLER

- 81148 16-1/2"(w) x 27"(h) - Ford Engine
- 80148 16-1/2"(w) x 27"(h) - Chevy Engine

- **N** (No Trans. Cooler: Std.)

BASE NUMBER

FINISH CHOICES

ELECTRIC FAN & SHROUD CHOICES

BUILT-IN TRANS. COOLER

'36 FORD



For use with one piece aftermarket hood.



See page 115 for wire harness options.

BUILD YOUR PART NUMBER... Example: 80149-S-NA-N

- **S** (Satin: Std.)
- **P** (Polished)
- **B** (Black)
- **F** (Fan & Shroud Only)

- **NA** (No Fan & Shroud: Std.)
- **SS** (Single Satin)
- **SP** (Single Polished)
- **SB** (Single Black)

WITH OR WITHOUT BUILT-IN TRANSMISSION COOLER

- 81149 17-1/4"(w) x 28"(h) - Ford Engine
- 80149 17-1/4"(w) x 28"(h) - Chevy Engine

- **N** (No Trans. Cooler: Std.)
- **Y** (w/ Trans. Cooler)

BASE NUMBER

FINISH CHOICES

ELECTRIC FAN & SHROUD CHOICES

BUILT-IN TRANS. COOLER

'37 FORD



See page 115 for wire harness options.

BUILD YOUR PART NUMBER... Example: 80142-S-NA-N

- **S** (Satin: Std.)
- **P** (Polished)
- **B** (Black)
- **F** (Fan & Shroud Only)

- **NA** (No Fan & Shroud: Std.)
- **SS** (Single Satin)
- **SP** (Single Polished)
- **SB** (Single Black)

NOT AVAILABLE WITH BUILT-IN TRANSMISSION COOLER

- 81142 16-1/2"(w) x 27"(h) - Ford Engine
- 80142 16-1/2"(w) x 27"(h) - Chevy Engine

- **N** (No Trans. Cooler: Std.)

BASE NUMBER

FINISH CHOICES

ELECTRIC FAN & SHROUD CHOICES

BUILT-IN TRANS. COOLER

STREET ROD COOLING

'38 FORD



BUILD YOUR PART NUMBER... Example: 80142-S-NA-N

81142 16-1/2"(w) x 27"(h) - Ford Engine
80142 16-1/2"(w) x 27"(h) - Chevy Engine

BASE NUMBER



- **S** (Satin: Std.)
- **P** (Polished)
- **B** (Black)
- **F** (Fan & Shroud Only)

FINISH CHOICES



- **NA** (No Fan & Shroud: Std.)
- **SS** (Single Satin)
- **SP** (Single Polished)
- **SB** (Single Black)

ELECTRIC FAN & SHROUD CHOICES

See page 115 for wire harness options.

NOT AVAILABLE WITH BUILT-IN TRANSMISSION COOLER

- **N** (No Trans. Cooler: Std.)

BUILT-IN TRANS. COOLER

'39 FORD STANDARD



BUILD YOUR PART NUMBER... Example: 80142-S-NA-N

81142 16-1/2"(w) x 27"(h) - Ford Engine
80142 16-1/2"(w) x 27"(h) - Chevy Engine

BASE NUMBER



- **S** (Satin: Std.)
- **P** (Polished)
- **B** (Black)
- **F** (Fan & Shroud Only)

FINISH CHOICES



- **NA** (No Fan & Shroud: Std.)
- **SS** (Single Satin)
- **SP** (Single Polished)
- **SB** (Single Black)

ELECTRIC FAN & SHROUD CHOICES

See page 115 for wire harness options.

NOT AVAILABLE WITH BUILT-IN TRANSMISSION COOLER

- **N** (No Trans. Cooler: Std.)

BUILT-IN TRANS. COOLER

'39 FORD DELUXE



BUILD YOUR PART NUMBER... Example: 80172-S-NA-N

81172 20-3/4"(w) x 26"(h) - Ford Engine
80172 20-3/4"(w) x 26"(h) - Chevy Engine

BASE NUMBER



- **S** (Satin: Std.)
- **P** (Polished)
- **B** (Black)
- **F** (Fan & Shroud Only)

FINISH CHOICES



- **NA** (No Fan & Shroud: Std.)
- **SS** (Single Satin)
- **SP** (Single Polished)
- **SB** (Single Black)

ELECTRIC FAN & SHROUD CHOICES

See page 115 for wire harness options.

NOT AVAILABLE WITH BUILT-IN TRANSMISSION COOLER

- **N** (No Trans. Cooler: Std.)

BUILT-IN TRANS. COOLER

STREET ROD COOLING

'37-'39 CHEVY



BUILD YOUR PART NUMBER... Example: 80144-S-NA-N

80143 17"(w) x 27"(h) - '38 Chevy Engine Only
80144 17"(w) x 27"(h) - '37 & '39 Chevy Engine Only

BASE NUMBER



- **S** (Satin: Std.)
- **P** (Polished)
- **B** (Black)
- **F** (Fan & Shroud Only)

FINISH CHOICES



- **NA** (No Fan & Shroud: Std.)
- **SS** (Single Satin)
- **SP** (Single Polished)
- **SB** (Single Black)

ELECTRIC FAN & SHROUD CHOICES

See page 115 for wire harness options.

WITH OR WITHOUT BUILT-IN TRANSMISSION COOLER

- **N** (No Trans. Cooler: Std.)
- **Y** (w/ Trans. Cooler)

BUILT-IN TRANS. COOLER

'38-'46 GM TRUCK



BUILD YOUR PART NUMBER... Example: 80147-S-NA-N

80147 17-3/4"(w) x 27"(h) - Chevy Engine

BASE NUMBER



- **S** (Satin: Std.)
- **P** (Polished)
- **B** (Black)
- **F** (Fan & Shroud Only)

FINISH CHOICES



- **NA** (No Fan & Shroud: Std.)
- **SS** (Single Satin)
- **SP** (Single Polished)
- **SB** (Single Black)

ELECTRIC FAN & SHROUD CHOICES

See page 115 for wire harness options.

NOT AVAILABLE WITH BUILT-IN TRANSMISSION COOLER

- **N** (No Trans. Cooler: Std.)

BUILT-IN TRANS. COOLER

'40 FORD



BUILD YOUR PART NUMBER... Example: 80172-S-NA-N

81172 20-3/4"(w) x 26"(h) - Ford Engine
80172 20-3/4"(w) x 26"(h) - Chevy Engine

BASE NUMBER



- **S** (Satin: Std.)
- **P** (Polished)
- **B** (Black)
- **F** (Fan & Shroud Only)

FINISH CHOICES



- **NA** (No Fan & Shroud: Std.)
- **SS** (Single Satin)
- **SP** (Single Polished)
- **SB** (Single Black)

ELECTRIC FAN & SHROUD CHOICES

See page 115 for wire harness options.

NOT AVAILABLE WITH BUILT-IN TRANSMISSION COOLER

- **N** (No Trans. Cooler: Std.)

BUILT-IN TRANS. COOLER

STREET ROD COOLING

'40-'41 FORD TRUCK



BUILD YOUR PART NUMBER... Example: 80172-S-NA-N

81172 20-3/4"(w) x 26"(h) - Ford Engine
80172 20-3/4"(w) x 26"(h) - Chevy Engine

BASE NUMBER



- **S** (Satin: Std.)
- **P** (Polished)
- **B** (Black)
- **F** (Fan & Shroud Only)

FINISH CHOICES



- **NA** (No Fan & Shroud: Std.)
- **SS** (Single Satin)
- **SP** (Single Polished)
- **SB** (Single Black)

ELECTRIC FAN & SHROUD CHOICES

See page 115 for wire harness options.

NOT AVAILABLE WITH BUILT-IN TRANSMISSION COOLER

- **N** (No Trans. Cooler: Std.)

BUILT-IN TRANS. COOLER

'42-'48 FORD



BUILD YOUR PART NUMBER... Example: 80141-S-NA-N

81141 18-3/4"(w) x 24"(h) - Ford Engine
80141 18-3/4"(w) x 24"(h) - Chevy Engine

BASE NUMBER



- **S** (Satin: Std.)
- **P** (Polished)
- **B** (Black)
- **F** (Fan & Shroud Only)

FINISH CHOICES



- **NA** (No Fan & Shroud: Std.)
- **SS** (Single Satin)
- **SP** (Single Polished)
- **SB** (Single Black)

ELECTRIC FAN & SHROUD CHOICES

See page 115 for wire harness options.

WITH OR WITHOUT BUILT-IN TRANSMISSION COOLER

- **N** (No Trans. Cooler: Std.)
- **Y** (w/ Trans. Cooler)

BUILT-IN TRANS. COOLER

'42-'48 CHEVY



BUILD YOUR PART NUMBER... Example: 80166-S-NA-N

80166 18-1/2"(w) x 24"(h) - Chevy Engine

BASE NUMBER



- **S** (Satin: Std.)
- **P** (Polished)
- **B** (Black)
- **F** (Fan & Shroud Only)

FINISH CHOICES



- **NA** (No Fan & Shroud: Std.)
- **SS** (Single Satin)
- **SP** (Single Polished)
- **SB** (Single Black)

ELECTRIC FAN & SHROUD CHOICES

See page 115 for wire harness options.

WITH OR WITHOUT BUILT-IN TRANSMISSION COOLER

- **N** (No Trans. Cooler: Std.)
- **Y** (w/ Trans. Cooler)

BUILT-IN TRANS. COOLER

STREET ROD COOLING

'49-'54 CHEVY



BUILD YOUR PART NUMBER... Example: 80139-S-NA-N

80139 22-3/4"(w) x 24"(h) - Chevy Engine

BASE NUMBER



- **S** (Satin: Std.)
- **P** (Polished)
- **B** (Black)
- **F** (Fan & Shroud Only)

FINISH CHOICES



- **NA** (No Fan & Shroud: Std.)
- **SS** (Single Satin)
- **SP** (Single Polished)
- **SB** (Single Black)
- **DS** (Dual Fan Satin)
- **DP** (Dual Fan Polished)
- **DB** (Dual Fan Black)

ELECTRIC FAN & SHROUD CHOICES

See page 115 for wire harness options.

WITH OR WITHOUT BUILT-IN TRANSMISSION COOLER

- **N** (No Trans. Cooler: Std.)
- **Y** (w/ Trans. Cooler:)

BUILT-IN TRANS. COOLER

'47-'55 CHEVY TRUCK - 1ST SERIES



BUILD YOUR PART NUMBER... Example: 80138-S-NA-N

80138 18"(w) x 26"(h) - Chevy Engine

BASE NUMBER



- **S** (Satin: Std.)
- **P** (Polished)
- **B** (Black)
- **F** (Fan & Shroud Only)

FINISH CHOICES



- **NA** (No Fan & Shroud: Std.)
- **SS** (Single Satin)
- **SP** (Single Polished)
- **SB** (Single Black)

ELECTRIC FAN & SHROUD CHOICES

See page 115 for wire harness options.

WITH OR WITHOUT BUILT-IN TRANSMISSION COOLER

- **N** (No Trans. Cooler: Std.)
- **Y** (w/ Trans. Cooler)

BUILT-IN TRANS. COOLER

'49-'53 FORD



BUILD YOUR PART NUMBER... Example: 80164-S-NA-N

81164 18-1/2"(w) x 24"(h) - Ford Engine
80164 18-1/2"(w) x 24"(h) - Chevy Engine

BASE NUMBER



- **S** (Satin: Std.)
- **P** (Polished)
- **B** (Black)
- **F** (Fan & Shroud Only)

FINISH CHOICES



- **NA** (No Fan & Shroud: Std.)
- **SS** (Single Satin)
- **SP** (Single Polished)
- **SB** (Single Black)

ELECTRIC FAN & SHROUD CHOICES

See page 115 for wire harness options.

NOT AVAILABLE WITH BUILT-IN TRANSMISSION COOLER

- **N** (No Trans. Cooler: Std.)

BUILT-IN TRANS. COOLER

STREET ROD COOLING

'53-'56 FORD TRUCK



BUILD YOUR PART NUMBER... Example: 80162-S-NA-N

81171 20-3/4"(w) x 25-1/8"(h) - Ford Engine
80162 20-3/4"(w) x 25-1/8"(h) - Chevy Engine

BASE NUMBER



- **S** (Satin: Std.)
- **P** (Polished)
- **B** (Black)
- **F** (Fan & Shroud Only)

FINISH CHOICES



- **NA** (No Fan & Shroud: Std.)
- **SS** (Single Satin)
- **SP** (Single Polished)
- **SB** (Single Black)

ELECTRIC FAN & SHROUD CHOICES

See page 115 for wire harness options.

NOT AVAILABLE WITH BUILT-IN TRANSMISSION COOLER

- **N** (No Trans. Cooler: Std.)

BUILT-IN TRANS. COOLER

'55-'57 CHEVY TRUCK - 2ND SERIES



BUILD YOUR PART NUMBER... Example: 80137-S-NA-N

80137 21-3/4"(w) x 25-1/2"(h) - Chevy Engine

BASE NUMBER



- **S** (Satin: Std.)
- **P** (Polished)
- **B** (Black)
- **F** (Fan & Shroud Only)

FINISH CHOICES



- **NA** (No Fan & Shroud: Std.)
- **SS** (Single Satin)
- **SP** (Single Polished)
- **SB** (Single Black)
- **DS** (Dual Fan Satin)
- **DP** (Dual Fan Polished)
- **DB** (Dual Fan Black)

ELECTRIC FAN & SHROUD CHOICES

See page 115 for wire harness options.

WITH OR WITHOUT BUILT-IN TRANSMISSION COOLER

- **N** (No Trans. Cooler: Std.)
- **Y** (w/ Trans. Cooler)

BUILT-IN TRANS. COOLER

'55-'57 CHEVY



BUILD YOUR PART NUMBER... Example: 80163-S-NA-N

80163 20-5/8"(w) x 21-7/8"(h) - '55-'56 Chevy Engine Only
80170 20-5/8"(w) x 21-7/8"(h) - '57 Chevy Engine Only

BASE NUMBER



- **S** (Satin: Std.)
- **P** (Polished)
- **B** (Black)
- **F** (Fan & Shroud Only)

FINISH CHOICES



- **NA** (No Fan & Shroud: Std.)
- **SS** (Single Satin)
- **SP** (Single Polished)
- **SB** (Single Black)
- **DS** (Dual Fan Satin)
- **DP** (Dual Fan Polished)
- **DB** (Dual Fan Black)

ELECTRIC FAN & SHROUD CHOICES

See page 115 for wire harness options.

WITH OR WITHOUT BUILT-IN TRANSMISSION COOLER

- **N** (No Trans. Cooler: Std.)
- **Y** (w/ Trans. Cooler)

BUILT-IN TRANS. COOLER

AFCO COOLING ACCESSORIES

COOLERS AND CONDENSERS

LONG TRANSMISSION/ENGINE/OIL COOLER

- Patented "Stacked Plate" cooler construction turns every inch of material into a cooling surface for maximum efficiency per cubic inch of package space.
- Can be used as an economy engine oil cooler.
- Embossed plate design maintains excellent performance with low pressure drop.



NUMBERS OF PASSES	SIZE (INCHES)	FITTING TYPE	PART#
12 PASSES	2.75 X 11 X 1.5	1/2NPTF	LB7B
24 PASSES	5.75 X 11 X 1.5	1/2NPTF	LL7B
36 PASSES	8.0 X 11 X 1.5	1/2NPTF	LM7B
48 PASSES	11.0 X 11 X 1.5	1/2NPTF	LH7B

AFCO INLINE TRANS. COOLER

- Easily mounts with two 1/4" bolts (included).
- Lower transmission temperatures up to 30 degrees.
- All aluminum construction.
- 1-3/4" diameter.

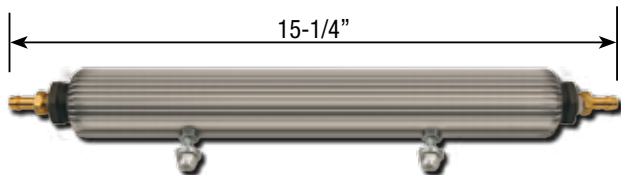

DESCRIPTION	PART #
INLINE TRANSMISSION COOLER	37750

AFCO CONDENSER

- Aluminum design.
- Use with 134 or R12 freon.
- Condenser fittings (5/8"-18 & 3/4"-16).



DESCRIPTION	PART #
15"(W) X 18"(T)	80168
12"(W) X 19"(T)	80169



ELECTRIC FAN ACCESSORIES

ELECTRIC FANS

These fans offer the best CFM vs. AMP draw of any electric units we have tested. They are shipped with an on-off switch or can be wired to a temperature sending unit.

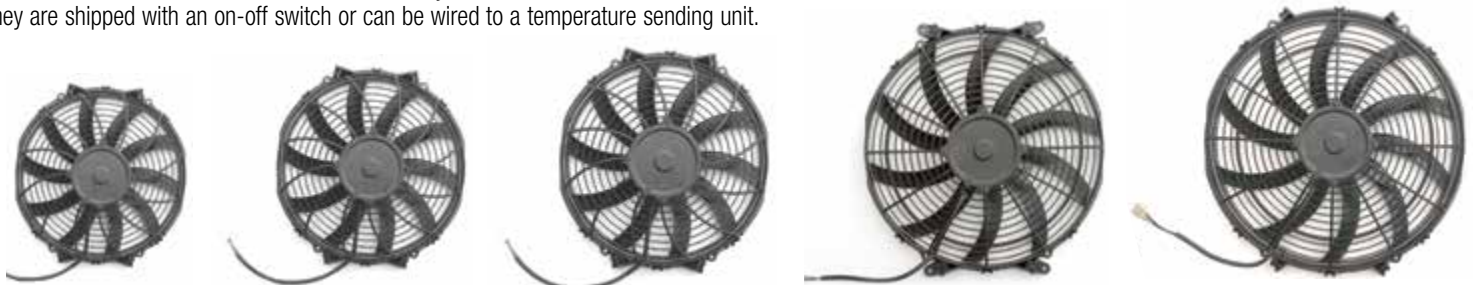

80176
8" 540 CFM

700050045
10" 802 CFM

80180
12" 1155 CFM

80179
14" 1555 CFM

80177
16" 2170 CFM

DIAMETER / TYPE	DEPTH	AMP DRAW	CFM	PART #
16" S-BLADE	3.06"	17.7	2170	80177*
14" S-BLADE	2.87"	10.1	1555	80179*
12" S-BLADE	2.48"	7.7	1155	80180*
10" S-BLADE	2.04"	6.0	802	700050045
8" S-BLADE	2.48"	6.9	540	80176*

ALL FANS INCLUDE 4 MOUNTING FEET. ALL FANS RATED AT ZERO STATIC. ALL FANS ARE GLASS-FILLED NYLON.

*FANS ARE REVERSIBLE.

ADJUSTABLE ELECTRIC FAN THERMOSTAT

- Externally adjustable fan activation temperature of 150 to 240 degrees allows you to custom set your fan activation.
- Recommended for single fan operation.
- May be wired to an AC-equipped car to operate the fan(s) anytime the AC is switched on to keep the AC operating cold.
- 3/8 male NPT temperature probe.
- ATC (blade-style) inline fuse.
- 30 Amp relay.



DESCRIPTION	PART #
FAN THERMOSTAT	80199
3/8" -18 FP FITTING (WELD-IN)	80128X10

ELECTRIC FAN SWITCHES

- Uses ground wire to switch current to fan.
- 1/4" fan switch turns on at 200° and off at 185°.
- 3/8" fan switch turns on at 195° and off at 175°.



DESCRIPTION	PART #
1/4" FAN SWITCH	85286
3/8" FAN SWITCH	85287

SINGLE FAN WIRE HARNESSES

- Single 40 Amp relay, single fuse, and single fusible link.
- All connectors and heat shrink included.
- Wire harness contained in wire loom.
- Fan leads and positive wire lead 10' long to allow mounting in any location.
- Controls single fan (Can be any brand of fan).
- Can be negatively controlled (using a temperature switch, part # 85286 or #85287) or positively controlled (using a toggle switch, part #85260).
- Can be controlled to operate by the ignition wire (to run only when the car is running) or to operate by the battery (to run until the car gets down to temperature whether the car is running or not).
- Full color instructions & all wires are labeled for easy installation.



DESCRIPTION	PART #
SINGLE FAN WIRE HARNESS	8000044401
DUAL FAN WIRE HARNESS	8000044402

DUAL FAN WIRE HARNESSES

- Dual 40 Amp relays, dual fuses, and dual fusible links.
- All connectors and heat shrink included.
- Wire harness contained in wire loom.
- Fan leads and positive wire leads 10' long to allow mounting in any location.
- Controls 2 fans (Can be any brand of fan).
- Can be negatively controlled (using a temperature switch, part # 85286 or #85287) or positively controlled (using a toggle switch, part #85260).
- Can be controlled to operate by the ignition wire (to run only when the car is running) or to operate by the battery (to run until the car gets down to temperature whether the car is running or not).
- Full color instructions & all wires are labeled for easy installation.

COOLANT RECOVERY TANKS

- Aluminum construction.
- Catches radiator overflow.
- Available in aluminum & polished stainless steel.
- Completes a closed system.
- 1 quart capacity.



DESCRIPTION

DESCRIPTION	PART #
A. COOLANT RECOVERY TANK (ALUMINUM)	80158
B. COOLANT RECOVERY TANK (ALUMINUM WITH BLACK THERMAL COATING)	80158B
C. COOLANT RECOVERY TANK (POLISHED STAINLESS)	80159

RADIATOR HOSES & TUBES

BLACK SILICONE RADIATOR HOSES

- High temp. hoses.
- Long life durability.

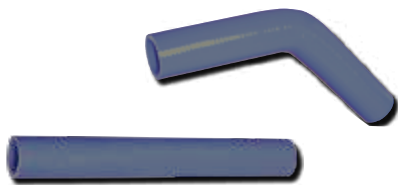

DESCRIPTION	PART #
6.00" X 1.25"	800-06-00-1.25BK
6.00" X 1.50"	800-06-00-1.50BK
6.00" X 1.75"	800-06-00-1.75BK
12.00" X 1.25"	800-12-00-1.25BK
12.00" X 1.50"	800-12-00-1.50BK
12.00" X 1.75"	800-12-00-1.75BK
45° - 12.00" X 1.25"	800-12-45-1.25BK
45° - 12.00" X 1.50"	800-12-45-1.50BK
45° - 12.00" X 1.75"	800-12-45-1.75BK
90° - 12.00" X 1.25"	800-12-90-1.25BK
90° - 12.00" X 1.50"	800-12-90-1.50BK
90° - 12.00" X 1.75"	800-12-90-1.75BK

BLUE SILICONE RADIATOR HOSES

- High temp. hoses.
- Long life durability.



DESCRIPTION	PART #
6.00" X 1.25" X 1.50"	801-08-1.25-1.50
6.00" X 1.25" X 1.75"	801-08-1.25-1.75
6.00" X 1.25"	800-06-00-1.25
6.00" X 1.50"	800-06-00-1.50
6.00" X 1.75"	800-06-00-1.75
12.00" X 1.25"	800-12-00-1.25
12.00" X 1.50"	800-12-00-1.50
12.00" X 1.75"	800-12-00-1.75
45° - 12.00" X 1.25"	800-12-45-1.25
45° - 12.00" X 1.50"	800-12-45-1.50
45° - 12.00" X 1.75"	800-12-45-1.75
90° - 12.00" X 1.25"	800-12-90-1.25
90° - 12.00" X 1.50"	800-12-90-1.50
90° - 12.00" X 1.75"	800-12-90-1.75

ALUMINUM RADIATOR TUBES

- Used with silicone hoses.



DESCRIPTION	PART #
135° - 1.25" TUBE SIZE	88135125
135° - 1.50" TUBE SIZE	88135150
135° - 1.75" TUBE SIZE	88135150
105° - 1.25" TUBE SIZE	88105125
105° - 1.50" TUBE SIZE	88105150
105° - 1.75" TUBE SIZE	88105175
90° - 1.25" TUBE SIZE	88090125
90° - 1.50" TUBE SIZE	88090150
90° - 1.75" TUBE SIZE	88090175
RUBBER CLAMP 1.5"-2"	88150200
RUBBER CLAMP 1.75"-2.25"	88175225

RADIATOR CAPS

Quality radiator caps help prevent the loss of coolant that can lead to overheating.



A
21-25 lbs. Pressure



B
20 lbs. Pressure



C
16 lbs. Pressure



D
16 lbs. Pressure



E
16 lbs. Pressure

DESCRIPTION

A) STANT 21-25 LBS. CAP

PART

80153

B) RADIATOR CAP-20 LBS.

80151

RADIATOR CAP-29-31LBS.

80050

C) BILLET ALUMINUM RADIATOR CAP (STREET USE) 16 LBS.

80152-16

D) BILLET ALUMINUM "AFCO" RADIATOR CAP (STREET USE) 16 LBS.

80094

E) BILLET ALUMINUM "AFCO" RADIATOR CAP (STREET USE)-BLACK 16 LBS.

80094B

KEVIN LUMSDEN

Kevin relies on AFCO Shocks and Madman & Company to keep his Camaro at the head of the class.



MISCELLANEOUS COOLING ACCESSORIES

ELECTRIC FAN MOUNTS



SHOWN INSTALLED

DESCRIPTION	PART #
FAN MOUNT	80197

FAN SPACER KITS

- Billet aluminum.
- Anodized black.
- Fits 5/8" or 3/4" drive.
- Kit comes with bolts, bushing, and washers.



DESCRIPTION	PART #
1-1/2" FAN SPACER	80191
2" FAN SPACER	80192
2-1/2" FAN SPACER	80193
3" FAN SPACER	80194

HD COOLING FANS

- 33° pitch.
- Dual bolt pattern to fit most pump.
- 6 steel blades.



DESCRIPTION	PART #
GM 15"	80182
GM 17"	80181

4 BLADE FAN

- Designed with the proper blade pitch to move the maximum amount of air possible.
- 4 steel blades for greater air flow.
- Dual bolt pattern to fit most pumps.



DESCRIPTION	PART #
4 BLADE FAN 17-1/2"	80183

INLINE FILLER

- Installs in upper radiator hose.
- 100% aluminum construction.



DESCRIPTION	PART #
ALUMINUM 1-1/2" O.D.	80155

ALUMINUM THERMOSTAT HOUSINGS

- Polished aluminum construction.
- Uses o-ring for quality seal to intake.
- Allows 360° rotation.
- Includes bolts.



DESCRIPTION	PART #
45° NECK SBC / BBC	80312-45
15° NECK SBC / BBC	80312-15

GATES HOSE CLAMP

- Installs with heat gun.
- Conforms to any shape.
- Never needs re-tightening.



DESCRIPTION	PART #
1.25" ID HOSE CLAMP	802-1.25
1.50" ID HOSE CLAMP	802-1.50
1.75" ID HOSE CLAMP	802-1.75
2.00" ID HOSE CLAMP	802-2.00

RADIATOR REPAIR KIT

Repairs small leaks in aluminum radiators.



DESCRIPTION	PART #
EPOXY SOLDER	80161

RADIATOR FILLER



DESCRIPTION	PART #
BILLET FILLER NECK	80154BK

**AN FEMALE O-RING
WELD-ON STYLE
BUNG**



DESCRIPTION	PART #
10 AN FITTING	80128X-10AN
12 AN FITTING	80128X-12AN
16 AN FITTING	80128X-16AN
20 AN FITTING	80128X-20AN

*O-RINGS SOLD SEPARATELY.

**WELD-ON
FITTINGS**



MALE	PART #
6AN FITTING	700050040
8AN FITTING	700050041
10AN FITTING	700050037
12AN FITTING	80128X8
16AN FITTING	80128X9
20AN FITTING	80128X20

FEMALE	PART #
1/8" FP FITTING	80128X12
1/4" FP FITTING	80128X5
3/8"-18 FP FITTING	80128X10
1/2"-14 FP FITTING	80128X11
3/4" FP FITTING	80128X6
1" FP FITTING	80128X7

COOLANT

- Ready to use premixed formula.
- Protects from -34° - 265° F (using 15 lbs. cap).
- Green, 100% biodegradable coolant in its unused form.
- Non-propylene glycol coolant for better thermal conductivity & heat transfer.
- Patented universal low silicate formula offers corrosion protection for modern engine materials.



DESCRIPTION	PART #
HIGH PERFORMANCE COOLANT (1 PINT)	100001

COOLANT ADDITIVE

- Glycol Free.
- Premium quality water/coolant additive that promotes increased heat transfer.
- 40% reduction of surface tension compared to plain water.
- More complex additive package than competition to protect against corrosion and rust.
- 100% biodegradable in its unused form.
- Specifically engineered for all aluminum engine systems.



DESCRIPTION	PART #
HIGH PERFORMANCE ADDITIVE (1 PINT)	100002

COOLANT COMBO KIT

- 2 gallons of high perf. coolant .
- Polished recovery tank.
- Billet AFCO cap.



Part #: 100042



AFCO APPAREL & MORE



Black
T-Shirt:

DESCRIPTION	PART #
T-SHIRT - AFCO BLACK (S)	89116-S
T-SHIRT - AFCO BLACK (M)	89116-M
T-SHIRT - AFCO BLACK (L)	89116-L
T-SHIRT - AFCO BLACK (XL)	89116-XL
T-SHIRT - AFCO BLACK (2X)	89116-XXL
T-SHIRT - AFCO BLACK (3X)	89116-XXXL
T-SHIRT - AFCO BLACK (4X)	89116-XXXXL



Black
T-Shirt:

DESCRIPTION	PART #
T-SHIRT - AT BLACK (S)	89108-S
T-SHIRT - AT BLACK (M)	89108-M
T-SHIRT - AT BLACK (L)	89108-L
T-SHIRT - AT BLACK (XL)	89108-XL
T-SHIRT - AT BLACK (2X)	89108-XXL
T-SHIRT - AT BLACK (3X)	89108-XXXL



Black
T-Shirt:

DESCRIPTION	PART #
T-SHIRT - AFCO BLACK (S)	89100-S
T-SHIRT - AFCO BLACK (2X)	89100-XXL



Black
T-Shirt:

DESCRIPTION	PART #
T-SHIRT - AFCO BLACK (S)	89117-S
T-SHIRT - AFCO BLACK (M)	89117-M
T-SHIRT - AFCO BLACK (L)	89117-L
T-SHIRT - AFCO BLACK (XL)	89117-XL
T-SHIRT - AFCO BLACK (2X)	89117-XXL
T-SHIRT - AFCO BLACK (3X)	89117-XXXL
T-SHIRT - AFCO BLACK (4X)	89117-XXXXL



AFCO Hoodie:

DESCRIPTION	PART #
HOODIE - AT SERIES AFCO	89115-L
HOODIE - AT SERIES AFCO	89115-M
HOODIE - AT SERIES AFCO	89115-S
HOODIE - AT SERIES AFCO	89115-XL
HOODIE - AT SERIES AFCO	89115-XXL
HOODIE - AT SERIES AFCO	89115-XXXL
HOODIE - AT SERIES AFCO	89115-XXXXL



Charcoal
T-Shirt:

DESCRIPTION	PART #
T-SHIRT - AFCO CHARCOAL (S)	89099-S
T-SHIRT - AFCO CHARCOAL (2X)	89099-XXL
T-SHIRT - AFCO CHARCOAL (3X)	89099-XXXL



AFCO Speed Equip.
Work Shirt:

DESCRIPTION	PART #
WORK SHIRT - AFCO NAVY (L)	89086-L
WORK SHIRT - AFCO NAVY (XL)	89086-XL
WORK SHIRT - AFCO NAVY (2X)	89086-XXL
WORK SHIRT - AFCO NAVY (3X)	89086-XXXL



AFCO Speed Equip.
Work Jacket:

DESCRIPTION	PART #
WORK JACKET - AFCO NAVY (L)	89085-L
WORK JACKET - AFCO NAVY (XL)	89085-XL
WORK JACKET - AFCO NAVY (2X)	89085-XXL
WORK JACKET - AFCO NAVY (3X)	89085-XXXL



AFCO Banner:

LIT-215



Ultimate^{QM}

Quarter Midget
Black Tee:

DESCRIPTION	PART #	DESCRIPTION	PART #
T-SHIRT - ULT. QM BLACK (YS)	89119-YS	T-SHIRT - ULT. QM BLACK (L)	89119-L
T-SHIRT - ULT. QM BLACK (YM)	89119-YM	T-SHIRT - ULT. QM BLACK (XL)	89119-XL
T-SHIRT - ULT. QM BLACK (YL)	89119-YL	T-SHIRT - ULT. QM BLACK (2X)	89119-XXL
T-SHIRT - ULT. QM BLACK (S)	89119-S	T-SHIRT - ULT. QM BLACK (3X)	89119-XXXL
T-SHIRT - ULT. QM BLACK (M)	89119-M		

APPAREL & MORE

DYNATECH

▶ DYNATECH T-SHIRT
89118



▶ DYNATECH HOODIE
89090



▶ 8' x 3' BANNER *BANNER*



▶ CAN COOLIE 89098



▶ STRETCH FIT **\$24⁹⁹**
89045



PRO SHOCKS

▶ PRO T-SHIRT 89101



▶ PRO COOLIE **\$2⁹⁹**
89107



COMPETITION SUSPENSION INC.

▶ CSI AMERICAN HOODIE
18300



▶ CSI AMERICAN T-SHIRT
28300



▶ CSI THROWBACK T-SHIRT
28300



▶ BLACK FLEXFIT MESH CSI HAT
89111



▶ TWO TONE FLEXFIT MESH CSI HAT
89113



ROBBIE STANLEY RACING

▶ RSR BLACK T-SHIRT
AP103



▶ RSR CAP AP104

