



# 4X4 ACCESSORIES



CATALOG 2019



## **4X4 ACCESSORIES**

# **TABLE OF CONTENTS**

### **COMPANY**

- 4 ARB History
- 6 Engineering
- 8 Manufacturing

### **PRODUCTS**

- 10 Bumpers & Protection Equipment
- 28 Recovery Equipment
- 40 Old Man Emu 4x4 Suspension
- 50 LINX Accessory Interface
- 54 Air Lockers
- 60 Air Compressors & Air Systems
- 68 Roof Racks
- 74 Storage Solutions
- 78 Performance Lighting
- 84 Tents, Awnings & Camping
- 96 Fridge Freezers
- 106 Safari Snorkels





▲ The previous ARB factory in Bayswater during the 1980s

# OUR STORY

## INNOVATING SINCE 1975

In 1975, Tony Brown, an experienced off-roader, headed for Cape York in his Series I Land Rover, but soon found himself spending much of his time helping fellow off-roaders in trouble on the trail. If he wasn't mending flimsy roof racks damaged by the heavy loads typical of Outback travel, he was repairing bumpers and various homemade items that had fallen apart in the difficult terrain. As Tony's familiarity of these product deficiencies grew, an idea was born—to produce high quality, durable equipment specifically engineered for punishing Outback conditions.

Upon his return to Melbourne, Tony set to work in the family garage. His products were to be based on a combination of reliable raw materials and sound design principles—a straightforward solution to a widespread problem. Starting with his own Series I Land Rover bumper, Tony began making custom-fabricated products that were immediately embraced when they hit the fledgling 4x4 market. At a time when bumpers were inadequate homemade creations, Tony's products showed proven durability and reliability on the trail.

The phenomenal demand from his fellow off-roaders enabled him to move to a 1000sq ft production facility later that same year, and ARB, the initials of Anthony Ronald Brown, was born.

Today, ARB is Australia's largest manufacturer and distributor of 4x4 accessories. What began with custom fabricated bumpers and roof racks has grown to include side rails, rear bumpers, Old Man Emu Suspension, recovery gear, canopies, Air Locker® locking differentials and a host of smaller items from air compressors to tire accessories. ARB has never forgotten its humble beginnings. The harsh conditions of Outback Australia demand resilient, hard working equipment, and ARB continues to focus on quality, reliability and practicality above all else. So whether it's traversing the Rubicon Trail, playing in Moab, or just heading off to a favorite local destination, you can rely on ARB 4x4 Accessories—your partner in adventure since 1975.



▲ 1975



▲ 1980s



**4X4 ACCESSORIES**

▲ Present Day



▲ ARB West Coast Staff



▲ ARB East Coast Staff

# OUR PEOPLE

## DRIVING PASSION

ARB staff are known for their passion and enthusiasm for off-roading and all things automotive. Many team members, including US HQ President Doug Pettis, were customers long before they were ARB employees.

We recognize that our success is derived from the strength, expertise and passion of our people, allowing us to maintain exceptionally high standards of customer service.



▲ ARB USA President, Doug Pettis



▲ Managing Director, Andrew Brown

# ENGINEERING

**ARB INVESTS SUBSTANTIAL AMOUNTS OF CAPITAL INTO RESEARCH, DESIGN AND MANUFACTURING EACH YEAR.**

In particular, the ARB Engineering Department, which is made up of over sixty qualified staff members, spends countless hours designing, testing and developing our product range to ensure ARB remains an innovator in the industry.

The process begins with concept designs, renderings, photo imaging and computer modeling, with qualified industrial designers using their industry knowledge to ensure the project is not only viable but also as functional as possible for the end user.

Engineers then use state-of-the-art equipment to gather as much vehicle-specific information as possible. Utilizing a FaroArm, engineers can easily perform 3D inspections and dimensional analysis to ensure the final product will fit your vehicle perfectly.

Specialized computer software is used to generate CAD models and perform Finite Element Analysis.



FEA simulates how the proposed part will react to many different situations, particularly with regard to performance under varying loads and forces, allowing our engineers to eliminate possible faults even before prototypes are created. Extensive field testing is also undertaken with data recorded for use in FEA and in further testing.

Once the CAD models are produced and engineering is satisfied with all FEA testing, a Failure Mode and Effect Analysis (FMEA) is performed. This test considers all of the conditions the product may be exposed to and ensures all aspects of the design comply with these conditions. A FMEA is also performed by our production engineering team to check for any possible faults that may arise during the production phase.

This extensive process is performed on all new fabricated parts and ensures our products consistently meet exceptionally high standards of quality, functionality and safety.



# MANUFACTURING



**ARB CONTINUES TO MAINTAIN ITS POSITION AS AN INNOVATOR IN THE INDUSTRY BY UTILIZING THE MOST MODERN, STATE-OF-THE-ART FABRICATION EQUIPMENT AND MACHINERY.**

Today's requirements for increasingly complex designs are met by ARB with some of the most advanced Computer Numerically Controlled (CNC) sheet fabrication facilities.

ARB's production facilities are equipped with a range of state-of-the-art machinery suited to the manufacture of metal products. Our manufacturing capabilities include laser cutting, guillotining, robot grinding, CNC bending, machining, and turning. We're equipped with MIG, TIG, robot and spot welding facilities and also have powder coating and spray painting centers.

ARB has a very highly skilled and motivated workforce at our manufacturing plants. We have stringent quality and environmental control systems in place, ensuring our exceptionally high standards are maintained. These factors, combined with our high level of automation, enable us to produce some of the finest four-wheel drive accessories in the world.

Finished goods are stored at ARB's main global warehouse in Melbourne, Australia. In addition to the products we make ourselves, you'll find floor-to-ceiling stacks of other leading brand name accessories such as Safari Snorkels and Bushranger. These products are built with the same uncompromising standards as our own, and have been carefully selected to complement the ARB product ranges.

Naturally, we provide a comprehensive warranty with our accessories. Products manufactured or solely distributed by us have a minimum two-year warranty.









**4X4 ACCESSORIES**

# **BUMPERS & PROTECTION EQUIPMENT**



# BUMPER ENGINEERING AND PRODUCTION

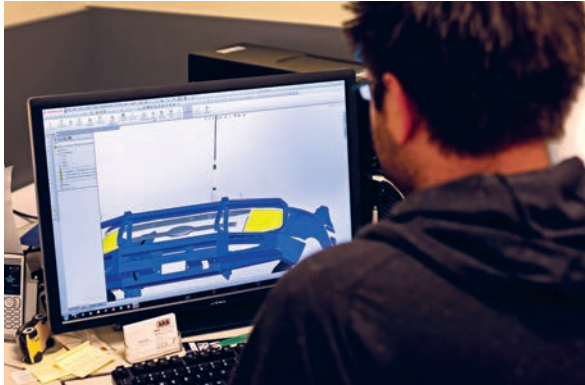

## ENGINEERING

Engineering a bumper requires careful consideration of a number of factors to ensure it properly serves its purpose. Factors such as vehicle design, crush rate, airbag deployment, approach angles, accessory fitment, strength, weight and aesthetics are incorporated into every ARB Bumper before it enters production.



## TESTING

ARB has invested heavily in vehicle crash barrier tests to validate the performance and compliance of our airbag compatible bumpers. To ensure compatibility, ARB assesses each vehicle's frontal crush characteristics and replicates the crush rate in the design of each airbag compatible bumper and mounting system. Using this method ensures that the vehicle's crush rate and airbag triggering are not altered when a bumper is installed.



## ASSEMBLY

When individual components are complete, the bumper is assembled. All sections—pan, wings, uprights, outer frame and chassis brackets—are placed in a jig and tack welded. This is followed by finish welding for strength and aesthetics.



## POST ASSEMBLY

To complete the manufacturing process, all ARB Bumpers are shot blasted before entering a five-stage chemical wash to prepare the surface for maximum powder adhesion. They're then powder coated and oven baked. The finished product boasts an attractive, yet durable look.

**YOU SIMPLY WON'T FIND A HIGHER QUALITY, MORE THOROUGHLY DESIGNED & MANUFACTURED PROTECTION SYSTEM THAN AN ARB BUMPER.**



## ▲ MANUFACTURING

Every bumper starts off as a flat sheet of steel. The components are cut into shape using ARB's in-house laser cutters, which produce highly accurate cuts to within 0.2mm, without any heat distortion. This process results in 100% accuracy, which is maintained throughout the entire fabrication of the bumper.

Using traditional forming in a multi-axis brake press as well as more advanced press forming where intricate shapes are required, flat sheets of steel are folded to make up each section of the bumper. Computer Numerically Controlled (CNC) machines are used to ensure maximum accuracy and consistency, while ARB's multi-fold design, used in most of our bumpers, provides optimal strength.

ARB Bumpers are manufactured with strong 2.6mm wall thickness tubing. The tube is cut to the desired length and bent with a CNC Eagle internal mandrel bender, ensuring consistency and even wall thickness across all sections.

Subsequent to being folded into shape, each section is welded utilizing a robot welder. Robot welders are used for straightforward, repetitive welding jobs that require speed and accuracy.



# SUMMIT BUMPER



Our flagship frontal protection system, the ARB Summit Bumper is a modern interpretation of the ARB Deluxe Bumper, designed to complement modern day vehicles, as well as provide additional features and strength related characteristics.

Press forming is utilized to produce the center pan, wing panels and cover straps, while a two piece grille with winch access port, recessed winch cradle, redesigned fog lights and buffers further enhance the style. The larger diameter top tube completes the overall aesthetics.

We haven't forgotten practicality. The Summit Bumper includes provisions for driving lights, CB antennas, and a range of electric winches built into the design. Importantly, the Summit Bumper is designed and engineered with safety in mind and is compatible with a range of modern-day safety features.

Also available is the Summit Sahara Bumper. Available with an optional polished or painted center tube, with provisions for CB antennas, the Summit Sahara Bumper is a modern interpretation of the Deluxe Sahara Bumper and is available for modern day vehicles.

Summit Bumpers are prepared with a zinc-rich primer for additional corrosion resistance and come in a black powder coat or a gritty Integrit™ finish.





# SUMMIT BUMPER

**Press-formed top pan and cover panel has been utilized to create a stronger center pan that features smooth, continuous edges.**

A press-formed aluminum winch cover panel finishes off the bar for when a winch is not installed.

**The Summit Bumper features 60.3mm mandrel-formed steel tubing providing increased frontal protection.**

From an aesthetic point of view, this offers greater visual styling to modern four-wheel drive designs.

**The Summit Bumper has been specifically designed with a wider edge radius.**

A 30mm wing and center section edge radius offers increased strength while complementing modern vehicle design.

**Perfect for driving in inclement weather, Summit Fog Lights provide a broad spread of light to illuminate the road ahead.**

Fog light surrounds are supplied as standard in a natural black finish.

**Eliminating the need for a mounting bracket, recovery jacking points are integrated into the design of most ARB Bumpers.**

Large, easy to access jack points make vehicle recovery safer and simpler when the bumper is not parallel to the ground.

**The mounting system is the single most important part of any ARB Bumper design.**

ARB's mounting systems are specifically engineered to spread impact and winching loads evenly over the vehicle's chassis. This ensures the bumper functions properly in extreme conditions.

**Exceptionally durable and secure, all ARB Bumpers serve as an ideal platform to mount driving lights, helping ensure maximum performance and longevity.**

Mounting driving lights to a high quality bumper prevents problems such as excessive movement, a vibrating beam pattern, premature bulb failure, and eventual fatiguing of the light assembly.





**THE SUMMIT BUMPER CONTINUES THE ARB TRADITION OF PIONEERING INNOVATION AND OUR RELENTLES PURSUIT OF QUALITY.**

**Provisions for CB antennas are incorporated into the center pan.**

Durable plugs are included for added aesthetics when antennas are not fitted, and additional tabs are included on the center tube.

**Mandrel Bent Tube**

An internal mandrel bender is used to shape the center tube, ensuring even wall thickness throughout.

**ARB's unique LED clearance/indicator lights are neatly installed behind press-formed apertures within each wing.**

12 high-intensity amber LEDs and 4 white LEDs provide increased light output in all conditions.

**The furthestmost point from the chassis and often the point of impact in an accident; the wing area is by far the most vulnerable.**

ARB pioneered the multi-fold upswept and tapered wing design, which provides an enormous amount of strength and maintains an optimum approach angle.

**Mounting a winch to a vehicle requires a properly supported structure that is designed to accommodate the stresses associated with winching.**

When using a snatch block to increase winching capacity, the forces are multiplied to several times the rated capacity of the winch. Most ARB bumpers feature the option of fitting a winch, and all are designed and tested to endure and exceed strenuous loads.

**With an airbag equipped vehicle, it is essential that the vehicle's crush rate and airbag triggering are not altered when a bumper is installed.**

ARB assesses each vehicle's frontal crush characteristics and replicates the crush rate into the design of each airbag compatible bumper and its mounting system. This achieves maximum vehicle and passenger protection without affecting the crash pulse.

**ARB's engineers give careful consideration to maintaining sufficient airflow to the vehicle's radiator.**

The wide, split pan design provides greater airflow to the radiator and the two-piece grille, which in turn, incorporates a hinged opening to allow access to the winch clutch handle.



# DELUXE BUMPER



ARB's Deluxe Bumper is renowned for its strength and practicality and is loaded with features aimed at making remote area travel safer.

The extensive range of features includes a completely steel construction, split-pan design to facilitate airflow; fully-engineered mounting system, and compatibility with modern vehicle safety features, such as; collision avoidance systems, parking sensors, and adaptive cruise control.

With bumper and winch compatible bumper options available for most vehicles manufactured prior to 2015, the Deluxe Bumper range is our most extensive.



# DELUXE SAHARA BUMPER



Sharing many of the strength related features of a Deluxe Bumper, the Sahara Bumper features ARB's multi-fold upswept and tapered wing profile, whilst also providing a solid platform for accessory fitment such as winches, driving lights and CB antennas.

Available either with or without a polished center tube, the Sahara Bumper offers owners greater flexibility in creating their desired look.

The Deluxe Sahara Bumper design is available for select vehicles manufactured prior to 2015, and offers a different style without sacrificing practicality.



# MODULAR BUMPER



Modern in styling yet distinctively ARB in heritage, the Modular Bumpers are truly innovative and utilize a modular design.

Three distinct configurations are available for each application, allowing for customization to meet individual needs or preferences. The integrated features were designed from the ground up as shown by the unique press formed fog light housings, the ability to mount a variety of winches (up to a Warn 16.5ti) within the bumper and our proprietary by our matte black Integrit finish powder coat. This bumper is available for select Chevrolet, Ford and Ram trucks.

The Modular Bumper models available begin with a Base Style bumper replacement which is an ideal winch platform. From there, you can select the Sahara Style which adds an upright hoop to guard the truck's grille and critical components. Finally, the Full Deluxe Modular Bumper adds outer frames providing the highest level of protection for the truck and occupants.



# STUBBY BUMPER



The Stubby Bumper has been developed for the off-roader who is after a winch platform, while maintaining maximum clearance for larger diameter tires. Generally vehicles that run larger than 35" tires may rub the tire on the wings of a traditional style ARB Deluxe Bumper. The Jeep Stubby Bumpers eliminates this issue with the bumper as wide as the vehicle's iconic grille panel.

Similar to our range of ARB Bumpers, the Stubby Bumpers feature a 3" main tube and each outer wing section with provisions for jacking points. Brackets are provided for fitment of driving lights to the bumper, and .79" thick 350 grade recovery points tie in through the wings and into the chassis mounting directly.

The winch platform will allow the mounting of most traditional low-mount style winches and narrow-mount pattern competition type winches.



# SKID PLATES AND SIDE PROTECTION



## ▲ SKID PLATES

Manufactured from laser cut, pressed and folded 3mm steel, ARB's Skid Plates are engineered to shield vulnerable under body components (such as the steering, oil pan, transmission and transfer case) from off-road debris.

Each vehicle specific-set includes protection panels that are directly bolted onto the chassis to provide protection from the ARB Bumper (if fitted) to the transfer case. The range has also been designed for practicality, with the ability for owners to easily remove the panels prior to vehicle servicing.



## ▲ ROCK SLIDERS

Engineered to take the weight of your vehicle and designed to protect door sills from rocks, logs and ruts, ARB Rock Sliders are manufactured from tough, tubular steel, making them ideal in challenging terrain.

**ARB'S SKID PLATE AND SIDE PROTECTION RANGES GUARD YOUR VEHICLE'S LOWER PANELS FROM ROCKS AND ROAD DEBRIS ENCOUNTERED IN REMOTE AREA TRAVEL.**



### ▲ **SUMMIT SIDE RAILS & STEPS**

Summit Side Rails and Protection Steps offer an all new attachment system, larger steel tubing and anodized aluminum tread plate, encompassing the very best in side protection.

Manufactured from 60.3mm tubular steel for added strength and durability, they come complete with a tough nylon cover sleeve to provide an integrated look between the bumper and side rail.



### ▲ **DELUXE SIDE RAILS & STEPS**

Manufactured from steel tubing and an aluminum tread top plate, the ARB Side Rails and Steps provide outstanding protection to lower panels from road debris and obstacles.

Fully compatible with side airbags, the system does not interfere in any way with your vehicle's safety systems. It is solidly mounted to the chassis, won't affect Safari Snorkel fitment, and aids entry to the vehicle and access to the roof.

# SUMMIT REAR BUMPER

## Adding to the protection characteristics of the bumper are steel diffuser panels.

Press formed from 1.6mm steel, and powder coated for corrosion resistance, the rear diffuser panels aid in protecting the underside of your four-wheel drive when you are off-roading.

## A high traction anodized tread panel allows safe access to the vehicle tub or roof.

Replacing the familiar aluminum checker plate traditionally found on ARB Rear Bumpers is a new silver anodized extruded aluminum section with ridges for grip. Additionally, an integrated license plate light is included if the factory light cannot be used.



## During off-road driving, the rear bed corners on pickups are quite vulnerable to damage.

The Summit Rear Bumper features replaceable, press formed steel wing panels that utilize three mounting points to the chassis for optimum strength and rigidity. Wing panels come standard in a black powder coat finish.

## A multipurpose, heavy-duty hitch receiver can accommodate a tow hitch or a rated recovery hitch.

Central to the practicality of the Summit Rear Bumper is the integrated heavy-duty towing system, featuring a 3.5t Class 4 2in hitch receiver as a standard fitment.



**ARB SUMMIT REAR BUMPERS COMBINE THE PROTECTION OF A REAR BUMPER WITH THE PRACTICALITY OF A FULLY FEATURED TOWING SYSTEM.**

**With protection being a major consideration in the design, Summit Rear Bumpers are engineered to withstand extreme terrain.**

The bumper is built around a 60.3mm x 2.6mm tubular steel subframe, with multiple chassis mounting points, designed to provide maximum clearance, minimizing the chance of contact with the ground over difficult terrain.

**Suitable for vehicles with or without rear parking sensors.**

Compatibility with modern vehicle safety systems was an imperative concern for ARB engineers when designing the bumper. As such, Summit Rear Bumpers are available for vehicles both with and without factory rear parking sensors.



**Practicality is delivered in spades with a plethora of connections available to make towing easier and safer.**

Tucked away safely behind a hinged steel access panel is the provision for securely mounting trailer plug wiring, as well as, an optional ARB Air Compressor outlet and a 50 amp Anderson plug.

**Jacking points offer versatility when recovering your four-wheel drive.**

Due to the strength of the steel frame and mounting system, ARB engineers have been able to incorporate four jacking points. One underneath each wing panel and one on either side of the rear diffuser panel.

# REAR PROTECTION

AN ARB REAR PROTECTION SYSTEM DELIVERS AN ENORMOUS AMOUNT OF STRENGTH AND VERSATILITY.



## ▲ SUMMIT REAR BUMPER

The Summit Rear Bumper combines class-leading design, proven ARB engineering and a no-compromise approach to protection and performance. Built around a tubular steel subframe that is finished in an Integrit textured black powder coat, the Summit Rear Bumper includes an integrated tow hitch and provisions for trailer plug wiring.

## FEATURES

- 3.5t Class 4, 2in tow hitch
- 2.5mm press formed steel wing panels
- Side wing panels can be color coded to suit vehicle (supplied in Integrit black powder coat)
- 60.3mm x 2.6mm steel tube frame
- Anodized aluminum top tread plate
- Narva LED license plate light (with molded bezel on some models)
- Replaceable 2mm zinc plated stone guards to reduce damage to the inner rear face of vehicle beaver panel (vehicle dependent)



▲  
**REAR BUMPER & CARRIER**

Four-wheel drive vehicles with the spare tire mounted on the back door can suffer from unnecessary door assembly stress, while a spare wheel located underneath a vehicle can be difficult to access, prone to damage and may affect ground clearance when driving off-road. Both of these mounting methods can also prove unsuitable if tires are upgraded to a larger size. ARB's range of rear bumpers, incorporating wheel carriers and jerry can holders, addresses all of these issues by relocating the spare tire onto the bumper assembly via a swing out carrier.

In most cases, the rear bumper will accommodate up to two 33" tires or a 35" tire and jerry can holder on the gas strut carriers. Owners are able to select which side of the rear bumper to fit the tire/jerry can carrier for added flexibility. Also featuring a heavy-duty towing system (most models), the rear protection system incorporates jacking points, replaceable wing sections and a multi-fit spare wheel stud system which provides flexibility for alternative rim selection.



▲  
**REAR BUMPER**

Not all vehicles require tyre carriers and jerry can holders. A rear bar alone provides greatly improved protection, versatility and vehicle access. Vehicle-specific design ensures excellent ground clearance and departure angles along with a stylish and adventurous look for your 4x4.

Manufactured from steel for maximum strength, the rear bumper (shown here with optional accessories) features

a center recess for various size tires on the factory door-mounted tire carrier (relevant models). Incorporated into the recess is low slip tread to facilitate easy access to both the roof and interior of the vehicle, while the vehicle specific design ensures excellent ground clearance and departure angles.



**4X4 ACCESSORIES**

# **RECOVERY EQUIPMENT**



# JACK

## WHAT HAPPENS WHEN ENGINEERS GET CREATIVE AND BRING HYDRAULIC TECHNOLOGY INTO THE RECOVERY SPACE? MEET JACK.

For any off-roader, it's a well-known fact that no matter how precisely a trip may be organized, things don't always go as planned; and when it comes to prepping your rig ready to kick up some dirt and battle the toughest terrains, you can count on the ARB JACK to have your back when tackling the trickiest of recovery missions.



### POWERFUL HYDRAULIC TECHNOLOGY

Adding a new dimension to traditional techniques, the long-travel ARB JACK is backed by the unique power of hydraulic technology. Kicking into action when even the lightest force is applied to the handle, the hydraulics will smoothly lift the vehicle up at half inch increments with each downward maneuver. While in action, a black rubber body bumper shields the vehicle from risk of damage during the recovery.

The easy-to-access red lowering lever ensures lowering the vehicle is achieved swiftly and safely thanks to the two-stage descent feature and safety stop. Empowering the user with dual lowering speeds, with a press of the lever, a slow or rapid descent can be achieved.



### KEEPING A LOW PROFILE

Carefully designed upon the importance of matching ergonomic form with safe and reliable function, the handle's high position and top pivot function provides users with ultimate control while preventing the need to uncomfortably kneel down in a deep trench to operate.



### READY FOR HEAVY LIFTING

Built tough to take on the grunt of the most challenging recovery missions, similar to the heavy-duty Old Man Emu BP-51 Shock Absorbers, JACK's body is made from aircraft grade 6061 T6 aluminum for maximum strength. Running up the body, 9 hooking points offer the adjustable hook a wide range of lifting heights; capable of lifting up to a total of 4400 lbs.

When under load, an internal blow-off valve provides overload protection to safeguard both JACK and most importantly, the user, from the dangerous consequence of the vehicle suddenly dropping if the working limit is exceeded.



### STAND YOUR GROUND WITH 360° ADJUSTABILITY

JACK's body can be rotated 360° to align the pivoting foot to match the terrain.

Additionally, the base of JACK is shaped perfectly for breaking the beads on your tire should the need arise.

JACK is compliant with the following standards and regulations:

- AS/NZ 2693 – 2007
- ASME B 30.1 – 2015



# TRED RECOVERY BOARDS

**TRED IS THE ULTIMATE ALL-IN-ONE OFF-ROAD RECOVERY DEVICE, SPECIALLY DESIGNED TO GET YOUR FOUR-WHEEL DRIVE, ATV AND EQUIPMENT OUT OF TROUBLE WHEN TRACTION IS LOST IN SAND, MUD, SLUDGE, OR SNOW.**

Engineered and manufactured in Australia from only the highest quality materials, TREDs are designed to handle intense levels of torque, flex, weight and impact. Intense reviews of every fine detail in the design process make TRED the best choice for recovery.

With a designated shovel feature, extreme hex grip nodules, aggressive ramp entry teeth and ultimate wear resistant properties, TRED Recovery Boards will allow you to explore with confidence, without letting traction disrupt your journey.

Since TRED's launch in 2012, TRED has sold in excess of 200,000 units. In this time the recovery board products have been developed to the extent that they are now the world's first non-mechanical recovery device to boast a lifetime warranty.





## TRED PRO

TRED Pro is the ultimate recovery device featuring unique composite teeth construction and layout, and special polyolefin material blend to handle extreme flex while remaining flexible and wear resistant.

- EXOTRED™ unique and patented composite construction
- SIPE-LOCK™ patented grip profile taken from the most popular tire brands
- Unique nylon material for superior flex and durability
- Special glass filled resin nylon teeth to reduce premature wear from wheel spin
- Various different colors available including two ARB branded exclusive colors
- Lower profile for stacking and storage



## TRED 1100 & 800

TRED Recovery Boards are engineered to allow for a swift and safe recovery when traction is lost suitable for everyone from the serious off-roaders to recreational family trips. TRED 1100 is 42.5" long, whereas TRED 800 is a more compact 31.1" long.

- Perfect for fast, solo recoveries
- Extreme hex grip nodules along entire length of the board
- Aggressive wear resistant ramp entry teeth to grab tires quickly, minimizing chance of wheel spin
- Unique nylon material for superior flex and durability
- Low profile for stacking and storage
- Various different colors available

# TRED ACCESSORIES



### TRED PRO BRACKET (TPMK)

Suitable for TRED Pro, 1100 and 800 and designed to be easy to mount in a variety of ways, the pro mounting brackets allow for the mounting of two sets (pairs) of the same model perfectly nested.



### TRED 1100 BRACKET (TRED11KM)

Designed to perfectly suit and secure the TRED 1100 and made from corrosion resistant materials.



### TRED LEASHES (TRED LEASH - TL1500) (ARB TRED LEASH - TLOARB)

Assist in locating your TREDs should they be buried beyond sight after a vehicle recovery.



### TRED CARRY BAGS (800 - TB800) (1100 - TB1100) (PRO - TPBAG)

Designed to protect your TREDs and allow ease of storage protecting your vehicle from mess. The TRED Pro Carry Bag has storage compartments and is perfect for use as a rear wheel trash bag.

# RECOVERY KITS



## PREMIUM RECOVERY KIT (RK9)

- 17,600lbs snatch strap
- 9,900lbs winch extension strap
- 26,000lbs tree trunk protector
- 19,800lbs snatch block
- Recovery damper
- Winch pack storage bag
- Two 4.75T bow shackles
- Recovery gloves



## ESSENTIALS RECOVERY KIT (RK11)

- 17,600lbs snatch strap
- 26,000lbs tree trunk protector
- 19,800lbs snatch block
- Snatch pack storage bag
- Two 4.75T bow shackles



## WEEKENDER RECOVERY KIT (RK12)

- 17,600lbs snatch strap
- Two 4.75T bow shackles
- Recovery gloves

# RECOVERY BAGS



## WINCH PACK (ARB501)

ARB's Winch Pack is designed to fit a complete recovery kit, including a snatch strap, tree trunk protector, winch extension strap, snatch block, recovery damper, bow shackles and gloves.



## SNATCH PACK (ARB502)

The snatch pack is a multi-purpose bag that will suit a variety of equipment, from recovery gear to camping supplies.



## COMPACT BAGS (ARB503)

Small enough to fit under or behind a car seat or in the back of a drawer system, the compact bag is available in two sizes and designed to carry a single strap and shackles.



## MICRO BAG (ARB504)

ARB's micro bag is perfect for smaller items such as a drag chain, shackles, snatch block, or general recovery items.

# RECOVERY STRAPS



## SNATCH STRAPS

ARB Snatch Straps are designed to stretch and return to their original length, aiding recovery and greatly reducing the likelihood of vehicle damage. The 17,600lbs model is recommended for most four-wheel drive vehicles, with the 24,000lbs and 33,000lbs straps better suited to heavier applications.

Part No.	Min. Break Strength	Length	Width	Stretch (Genuine)	Material	Reinf. Eyes	Eye & Seam Prot. Sleeves
ARB705LB	17,600lbs	29ft	2.3in	20%	100% Nylon	●	●
ARB710LB	24,000lbs	29ft	3in	20%	100% Nylon	●	●
ARB715LB	33,000lbs	29ft	4.3in	20%	100% Nylon	●	●



## WINCH EXTENSION STRAPS

Manufactured from durable polyester material, the ARB Winch Extension Strap is the ideal way to extend the length of your winch's cable when a suitable anchor point is out of reach.

Part No.	Min. Break Strength	Length	Width	Material	Reinf. Eyes	Eye & Seam Prot. Sleeves
ARB720LB	9,900lbs	65.6ft	2in	100% Polyester	●	●
ARB725LB	17,600lbs	65.6ft	3in	100% Polyester	●	●



## TREE TRUNK PROTECTORS

ARB's Tree Trunk Protector features 3in wide webbing which eliminates damage to both your equipment and the tree to ensure a safe vehicle recovery.

Part	Min. Breaking Strength	Length	Width	Material	Rein. Eyes	Eye & Seam Prot. Sleeves
ARB730LB	26,000lbs	9.8ft	3in	100% Polyester	●	●
ARB735LB	26,000lbs	16ft	3in	100% Polyester	●	●

# SNATCH BLOCKS



An ARB Snatch Block increases the capabilities of either a vehicle-mounted or portable winch by doubling the winch' capacity and halving the load. Manufactured from press-formed steel with solid billet or polymer pulley (model specific), ARB Snatch Blocks are designed to eliminate the possibility of the winch cable becoming trapped between the

pulley and the side plates. Featuring a tapered center groove that minimizes lateral cable movement, the ARB Snatch Block allows for a variety of cable sizes and winching from various angles when straight ahead isn't the best option.

## SPECIFICATIONS

Part No.	Working Load	Breaking Strength	Side Plate Material	Pulley Material	Pulley Diameter	Cable Size	Weight	Greasable
ARB209A	15,000lbs	31,900lbs	5mm Cold Rolled Steel	Solid Billet Steel	3.6in	0.24in-0.47in	7.7lbs	●
10100020	19,800lbs	38,500lbs	6mm Cold Rolled Steel	Specialized Polymer	4.3in	0.31in-0.51in	5.29lbs	N/A

# RECOVERY POINTS



Manufactured from steel plate, ARB's vehicle-specific recovery point range offers a safe and secure snatch point during vehicle recovery. All ARB Recovery Points are specifically rated for use with a 4.75t bow shackle and 17,600lbs snatch strap, eliminating the guesswork involved in snatch strap selection.

As a result of extensive research and design involving actual chassis samples and CAD data, all ARB Recovery Points feature vehicle-specific mounting systems and are engineered to ensure fitment does not adversely affect airbag deployment.

## FEATURES

- Vehicle-specific design
- Airbag compatible
- Rated for use with a 4.75t bow shackle and 17,600lbs snatch strap
- Rated to handle an angled pull, up to the maximum turn angle of the vehicle's front wheels
- Suitable for use as a winching point
- Manufactured from steel plate
- Durable powder coat finish
- Engineered and manufactured in Australia

# RECOVERY ESSENTIALS



## SOFT SHACKLE (ARB2017)

Staying safe is paramount in a recovery situation, which is why correctly rated gear should be at the forefront of selecting the right recovery equipment for your situation.

The ARB Soft Connect Shackle is manufactured using UHMWPE (Ultra High Molecule Weight Polyethylene) a high tensile CE certified rope used in many synthetic rope applications like winches and purpose-built tow straps.

Rated at 14.5T breaking strength and suitable for vehicles up to 3.5T, the ARB Soft Connect Shackle is engineered to float in water and provide superior strength during recovery missions. Furthermore, they're encased within a Hypalon sleeve for added protection to the rope from cuts and abrasions.

## SHACKLES (ARB207B - 3.25T) (ARB2014 - 4.75T) (ARB207E - 8.25T)

The importance of recovery shackles in particular cannot be underestimated for vehicle recovery. For most vehicles a shackle is required to safely attach a recovery strap to the vehicles recovery point. ARB has a range of recovery shackles that cater to the largest heavy duty trucks to the smallest SUV. Shackles range from 1T to 8T working load.



## BUSHRANGER X-TRAX (54X07)

For a quick and easy recovery solution in sand, mud and snow, Bushranger X-Trax are made with heavy-duty rubber with galvanized steel cables and fittings and come in a quick release carry bag.





◀

## X-JACK EXHAUST JACK (72X10)

With a lifting capacity of 8,800lbs, the X-Jack provides up to 30" of vehicle lift and is inflated via a high temperature hose that connects to the engine's tailpipe.

### FEATURES

- Provides up to 30" of lift
- 8,800lbs lifting capacity
- Wide footprint to avoid sinking in unstable areas of mud, snow, and sand
- Triangular spike shaped feet keep unit firmly grounded
- Triple-layer top and hardcore insert for added protection
- Unique two-way inflation system
- Can be used with vehicle exhaust or portable compressor
- Collapses flat for convenient storage

▶

## GLOVES (GLOVEMX)

The ARB Recovery Gloves provides knuckle and palm protection with molded rubber impact guards. These gloves use high quality synthetic materials to reduce abrasion and wear, as well as increase comfort on your hand, ideal for use with wire or synthetic rope winch cables. Added protection to the palm and fingers provide a safe, yet good dexterity glove with a firm fitment which reduces pinching hazards.

The cuff is embedded with the ARB Recovery logo and high quality touch tape fastener to keep the glove firmly fitted. Finished in a breathable microfiber and ARB Hi-Vis recovery orange (great for spotting), these gloves will complement your already excellent ARB recovery range.



◀

## RECOVERY DAMPER (ARB220)

In the unlikely event of a wire rope or strap failure, the recovery damper will absorb most of the energy in the cable or strap, thereby significantly reducing the recoil.

The ARB Recovery Damper is manufactured from heavy-duty vinyl and features storage pockets which come in handy for carrying snatch blocks and shackles when walking from your four-wheel drive to an anchor point.

As recovery dampers are now mandatory accessories for most four-wheel drive competitions, the ARB Damper exceeds minimum competition weight requirements.









**OLD MAN EMU**  
4X4 SUSPENSION BY ARB

# **OLD MAN EMU 4X4 SUSPENSION**



# OLD MAN EMU 4X4 SUSPENSION



## WHY UPGRADE YOUR SUSPENSION?

A very common question asked by four-wheel drive owners is, "Why would I upgrade the suspension on my brand new vehicle?"

From the factory, most new four-wheel drive vehicles are tuned for comfort during on road driving. Once weight is added in the form of accessories and cargo, and road conditions deteriorate, performance and reliability suffer.

Quality, application specific aftermarket suspension is designed to increase load carrying capability and improve both vehicle handling and comfort across all terrains, while providing increased ground clearance to better tackle more challenging conditions. Unlike some other accessories, you'll notice the benefits of a new suspension system every time you drive your vehicle.

## WHY OLD MAN EMU?

Suspension systems, especially when referring to four-wheel drive vehicles, are extremely complex. Determining the right solution for each four-wheel drive requires special attention to many factors, with weight being the most critical. Old Man Emu 4x4 Suspension by ARB approaches this in a unique way. Instead of offering a compilation of parts that have been chosen primarily to increase the vehicle's ride height, OME 4x4 Suspension provides a range of tuned, matched and integrated systems, each offering optimum levels of comfort, load carrying capability and control characteristics. Part of this process involves tailoring the shock absorber valving to work with the different springs in our range, often resulting in two or three shock absorber part numbers being available for an individual vehicle.

The complete Old Man Emu Suspension range incorporates more than just 4x4 shock absorbers and springs. At ARB, we take integration to the highest level with our own selection of bushings, U-bolts, center bolts, spring liners, trim packers and suspension fitting kits.

**OLD MAN EMU IS SIMPLY UNRIVALLED BY ANY OTHER SUSPENSION COMPANY FOR COMFORT AND PERFORMANCE.**



## **DEVELOPMENT & SAFETY**

Old Man Emu development work has an unrelenting, no compromise approach, with ARB employing a team of full-time Ride Control Engineers to carry out an exhaustive testing and development program on each component in an Old Man Emu Suspension system.

Utilizing a long list of sophisticated test equipment including MoTeC data acquisition, Finite Element Analysis (FEA) programs, spring and shock dynamometers, and Solidworks design and analysis programs, Old Man Emu Engineers leave no stone unturned in order to deliver the ultimate in comfort, control and reliability.

During development, each new Old Man Emu Suspension system is tested not only for practical performance, but also to ensure compatibility with modern vehicle safety features such as Electronic Stability Control, an area in which ARB has invested heavily.

## **SALES & SERVICE**

Old Man Emu products are exported to over 100 countries worldwide.

Backed by a three-year, 37,000 mile warranty, Old Man Emu delivers aftersales service that is unmatched by any other suspension company.

# BP-51 HIGH PERFORMANCE BYPASS SHOCK ABSORBERS



Designed, developed and tested entirely in-house by ARB's team of Old Man Emu Ride Control Engineers, BP-51 Shock Absorbers are vehicle-specific and utilize existing mounting locations to provide easy installation without the need for additional vehicle modification.

Unlike most other adjustable shock absorbers, which provide adjustment for compression only, the BP-51 range allows on-vehicle, independent adjustability, of both rebound and compression. This allows for class-leading ride customization that can be tailored to individual vehicle or trip requirements.

## DEVELOPMENT & MANUFACTURING

All BP-51 Shock Absorbers are manufactured in-house by ARB. In order to achieve this, ARB has significantly invested in state-of-the-art machining and hard anodizing equipment. This allows ARB to have total control over the manufacturing process to ensure the highest possible quality.

BP-51 Shock Absorber bodies are manufactured using aircraft grade (6061 T6) anodized aluminum to dissipate heat more efficiently than steel or alloy steel and provide superior corrosion resistance.

ARB undertook extensive lab, real-world and destructive testing during the development process to ensure that reliability, longevity, and performance all meet ARB's impeccable standards.

## BYPASS TECHNOLOGY

In addition to the velocity-sensitive damping used in most shock absorbers (where the faster the piston moves, the higher the level of damping is generated), BP-51 Shock Absorbers also generate damping dependent on the position of the piston within the shock absorber's body via their bypass design.

Typical shock absorbers are only able to provide damping based on fluid transfer through the piston. BP-51's unique bypass design offers the best of both worlds, allowing the high performance oil to pass directly through the piston while also being channelled around this assembly via the bypass passages. The result is a shock absorber which can adapt to any terrain, providing increased ride control at the upper and lower travel limits.

With greater levels of damping generated at each end of the stroke, the piston slows as it approaches full compression and extension, preventing harsh topping out and allowing larger bumps and corrugations to be absorbed more easily. This results in an ability for the shock absorber to provide the best of both worlds, with a comfortable and compliant ride during normal driving and a more controlled ride over challenging terrain. The BP-51 range is backed by a three-year, 37,000 mile warranty.

**THE BP-51 RANGE OF HIGH PERFORMANCE, BYPASS SHOCK ABSORBERS IS THE RESULT OF AN EXHAUSTIVE DEVELOPMENT PROCESS AIMED AT DELIVERING THE ULTIMATE IN BOTH COMFORT AND CONTROL.**

**INTERNAL FEATURES**

- Bypass, shim-controlled, position sensitive damping (patent pending)
- Multiple compression and rebound bypass zones for smoother transition
- Kidney bypass ports for maximum bore size and bypass flow area
- High performance, high viscosity index oil
- 1900MPa polished, high strength, high fatigue life shims

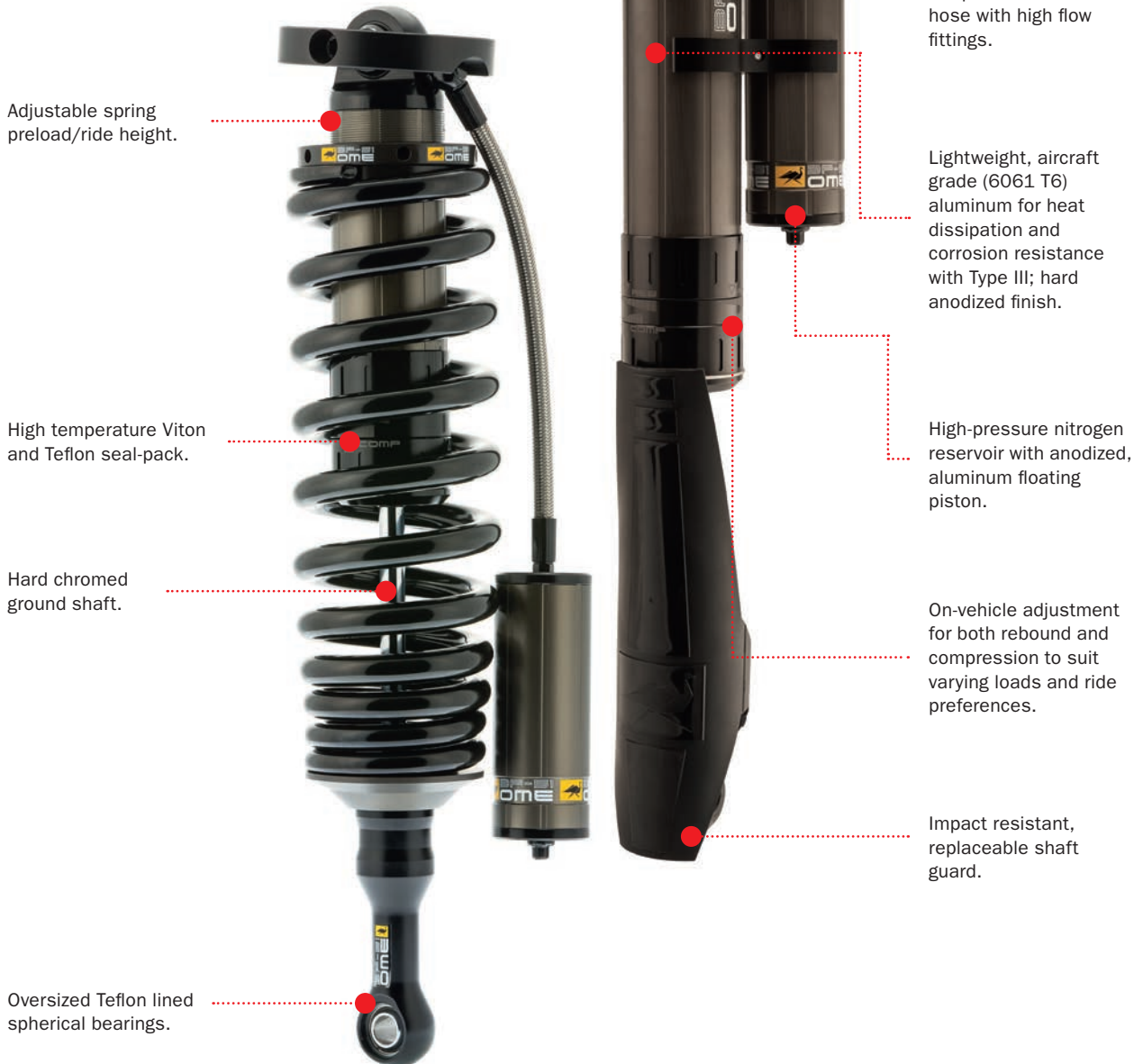

Adjustable spring preload/ride height.

High temperature Viton and Teflon seal-pack.

Hard chromed ground shaft.

Oversized Teflon lined spherical bearings.

Vehicle-specific applications with no fitting modifications required.

Dash 6 high temperature Teflon hose with high flow fittings.

Lightweight, aircraft grade (6061 T6) aluminum for heat dissipation and corrosion resistance with Type III; hard anodized finish.

High-pressure nitrogen reservoir with anodized, aluminum floating piston.

On-vehicle adjustment for both rebound and compression to suit varying loads and ride preferences.

Impact resistant, replaceable shaft guard.

# NITROCHARGER SPORT SHOCK ABSORBERS



The Nitrocharger Sport range is the result of an exhaustive development program targeted at producing an advanced shock absorber with the capacity to deliver vast improvements in ride control, load carrying, durability and vehicle-specific fine-tuning. Utilizing significant advances in key components and the latest in valving technology, Nitrocharger Sport Shock Absorbers provide tremendous improvements in ride, comfort, and handling over all terrains.

The requirements of one vehicle owner can be vastly different to another. Because of this, several Nitrocharger Sport Shock Absorber applications are typically listed for one vehicle model to ensure the proper valving is matched to the spring selection, accessory fitment and load carrying requirements. Durability has been proven under extensive laboratory and Outback testing, supported by scientific data logging and all valving work carried out in Australia by OME's Ride Control Engineers.

A competition range is also available, which features all of the standard Nitrocharger Sport features, with an additional 50mm of open length and a corresponding closed length for even greater handling and control in off-road motorsport.

Built in Australia and trusted by off-roaders throughout the world, Nitrocharger Sport Shock Absorbers set the standard in fine-tuning and ride comfort over any terrain, and simply outperform the competition.

Fully compatible with OME's extensive range of springs, bushings and hardware, the Nitrocharger Sport range is backed by a three-year, 37,000 mile warranty.

**THE NITROCHARGER SPORT RANGE TAKES THE NEXT STEP IN VEHICLE-SPECIFIC VALVING AND OFFERS THE MOST COHESIVE, BALANCED, AND FINELY-TUNED VALVING SYSTEM ON THE MARKET.**

Vehicle-specific bushings manufactured from polyurethane and rubber materials for extended life.

Impact-resistant, polyamide dirt shield provides additional protection from stone chips and off-road debris.

18mm induction hardened chrome piston rod engineered to handle the rigours of heavy loads and tough 4x4 adventures..

Nitrogen gas increases the temperature operating range and improves oil flow through the valving, ensuring optimum performance.

Petroleum-based, high-performance oil designed to resist fade and aeration for improved durability and shock absorber performance.

Heavy gauge steel reserve tube is 23% more effective than common 1.3mm wall tubing to protect internal components from stone damage.

Located at the base of the shock absorber, this stack offers significant valving advantages by combining the bleed disc with five thinner discs. This translates to a more rounded and comfortable ride over patchy and uneven road conditions. Using different diameter disks creates a second advantage—multi-stage compression stack which generates a comfortable ride together with a stronger second stage that gives more control in rougher conditions.

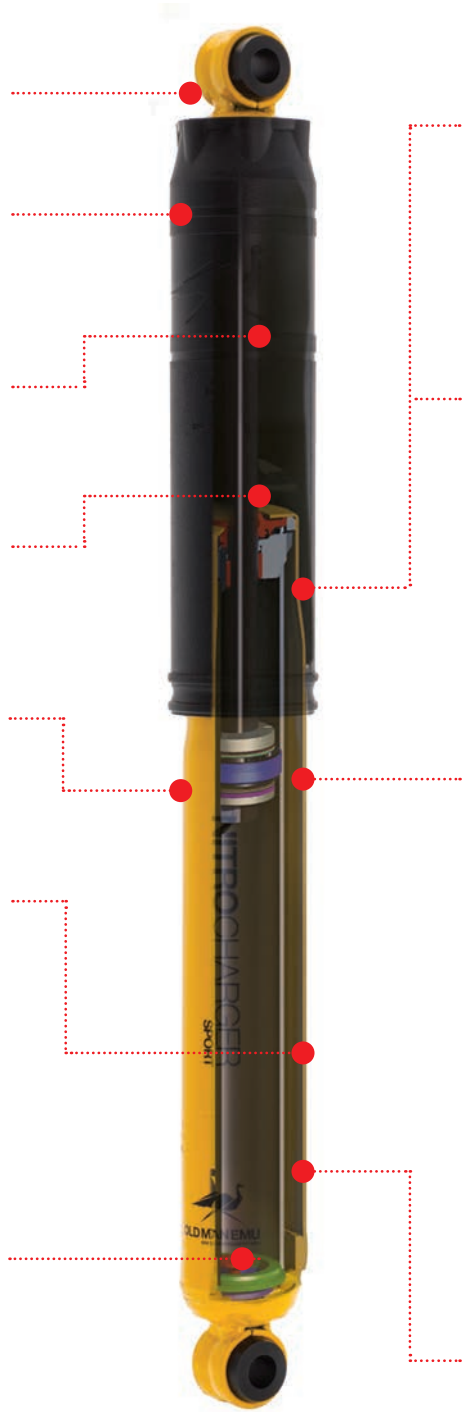

The rod guide has been engineered with a less restrictive design and open apertures to ensure a more uniform oil flow through the disc stacks. This improves control over a higher temperate range. As the shock absorber heats up, oil flow over the valving remains stable, giving dependable, fade-free damping. A Teflon infused bronze slip ring has also been incorporated into the rod guide to ensure tight manufacturing tolerances are maintained.

Capable of handling greater internal pressures and higher temperatures, a triple lip oil seal incorporates a gas retention check valve to virtually eliminate contaminant damage and provide outstanding gas and oil retention.

The combination of the compression and rebound stacks enable OME Engineers to produce the most finely-tuned 4x4 shock absorber on the market. Specifically tailored to individual vehicle models and intended uses, this assembly also enables the shock absorber to instantly adapt to the road surface, guaranteeing rapid valving responses and improvements in ride quality, handling and control. Located above the piston is a major innovation unique to Nitrocharger Sport. Tuned to influence oil flow returning above the piston, this area of compression works in conjunction with the cylinder end compression valving to produce dynamic balance of oil distribution throughout the shock absorber. This in turn permits even greater fine tuning for vehicle-specific valving. Advantages of this include; better control and more comfort over uneven terrain—particularly at slower speeds. With up to ten discs used to control rebound, the piston-based rebound stack allows multi-staging of the mid range for initial control over small road imperfections, and heavier and more commanding control for harsher conditions.

It has a high-flow piston design to reduce aeration and high oil temperature, which extends shock absorber performance under harsh conditions.

# COIL SPRINGS

ARB designs an extensive range of Old Man Emu Coil Springs for each vehicle, utilizing state-of-the-art micro-alloyed spring steel to ensure superior resistance to sagging and corrosion. With such a wide product range, coil springs can be better matched to your specific load requirements and intended vehicle usage.

While ride height increases are attained, a greater emphasis is placed on ride control improvements. Further fine-tuning is achieved when the springs are matched to a corresponding set of Old Man Emu Shock Absorbers, delivering a fully integrated system designed specifically to suit your vehicle.

## FEATURES

- Manufactured from state-of-the-art micro-alloyed spring steel for superior strength and durability
- Double scragged before and after shot peening to reduce spring stress and enhance spring life
- Constant and variable rate coils available for multiple applications
- Formed on computer-controlled precision mandrels to ensure manufacturing consistency
- Spring end configurations designed to exact specifications, guaranteeing perfect fitment to your vehicle
- Finished in durable, hard wearing epoxy black powder coat
- Designed and manufactured in Australia



# LEAF SPRINGS

Old Man Emu Leaf Springs are engineered to provide optimum ride performance irrespective of the operating conditions.

Numerous spring options are available to suit a multitude of applications, allowing you to set your vehicle up for recreational or commercial purposes. Feature packed, a set of Old Man Emu Leaf Springs, matched to a set of Old Man Emu Shocks, will deliver vastly improved ride, handling and load carrying capability.

NOTE: Most Old Man Emu Leaf Springs have all the listed features, but where design or a physical limitation exists, one or more of these features may not be incorporated. Please check with your OME authorized dealer for further information.



## FEATURES

- Draw-tapered and diamond-cut leaves ensure the load is progressively distributed over a larger surface area, reducing the high stresses that develop at leaf ends, and increasing ride comfort and longevity
- Leaf clamps are bolted to allow installation of anti-squeak nylon liners
- Fully scragged to ensure the spring takes a permanent 'set' which reduces the risk of sagging
- Load testing ensures the spring meets the required specification
- Military wrap, designed to provide added safety
- Nylon interleaf anti-friction pads reduce friction at the leaf tips where the load is the greatest
- Flat axle seat area allows a positive, safe axle mount, reducing spring stress and increasing spring life
- The tension side of all leaves is shot peened to reduce spring stress, which can double the life of a spring
- Two-stage leaf pack featured on most rear springs for optimum comfort (When unladen, the vehicle is largely riding on the primary stage, with the secondary stage providing additional support when a heavy load is added)



# OME ESSENTIALS



## ▲ STEERING STABILIZERS

Designed to reduce the effect of wheel vibration and improve the feel, handling and control of the vehicle, OME's Steering Stabilizers will also reduce the aggressive rotation of the steering wheel over rough roads without affecting steering wheel return.

### FEATURES

- Nine-stage coil spring valving allows for optimum performance
- 15mm piston rod is stronger than the original equipment part
- Steel stone guard protects the piston rod against stone damage
- 35mm piston and bore allows increased oil volume
- Twin-tube design protects the internal components against stone damage
- Multi-lip seal prevents oil loss
- Original stabilizer mounts are used where appropriate for ease of installation



## ▲ TORSION BARS

Old Man Emu Torsion Bars dramatically improve your vehicle's ride and handling, both on road and off. They are designed and set for optimum ride performance, while maintaining maximum wheel travel which is crucial during off-road driving. Old Man Emu Torsion Bars work best when Old Man Emu Coil or Leaf Springs are fitted to the rear of your vehicle, with bars and springs then carefully matched to our premium range of four-wheel drive shock absorbers. Together, they'll transform your vehicle's suspension performance.



## ▲ GREASABLE SHACKLES

Should your Old Man Emu 4x4 Suspension system include leaf springs, the included bushings require periodic lubrication to ensure longevity. OME Greasable Shackles and Pins facilitate this without the need to remove the shackles, greatly reducing the time and effort involved.

### FEATURES

- Unique, easy bolt together assembly eliminates out of angle 'shackle pin to side plate' problems commonly associated with press fit assemblies
- Each pin has two grease inlet holes to guarantee maximum grease coverage between the shackle pin and the spring bushing – increasing bushing life and improving ride quality
- Heat treated pins ensure long life under heavy loads and off-road conditions
- Side plates are zinc-plated for protection against corrosion



## ▲ BUSHINGS

OME offers a variety of urethane and rubber bushing kits for shock absorbers, leaf springs, panhard rods, control arms and sway bars. Unique features like our exclusive splined leaf spring bushings and caster correction kits ensure proper performance.



## ▲ HARDWARE

The OME range doesn't just stop with shocks, springs and bushings. At ARB we take integration to the highest level with our own range of u-bolts, center bolts, spring liners, trim packers, and suspension fitting kits.

# LINX

VEHICLE ACCESSORY INTERFACE





# LINX **ARB**

VEHICLE ACCESSORY INTERFACE

**ONE DISPLAY.  
ONE CONTROLLER.**



## ▲ LINX (LX100)

There are two main components to LINX: a dash-mounted touchscreen display and an out-of-sight controller.

The touchscreen and controller share sensor data so that the system recognizes if lights are on, the vehicle ignition is in the on position or batteries are running low. The touchscreen display has built-in GPS to determine vehicle location and speed to enable automatic engagement or disengagement of some vehicle accessories.

### 6 PRE-INSTALLED MODULES

- Front & Rear Traction
- Pressure Control
- Accessory Switchboard
- Battery Monitor
- Speedometer
- Air Suspension Control

### OPTIONAL ACCESSORIES

- Pressure Control Kit
- Air Suspension Isolation Kit
- LINX Vehicle-Specific Mount

### WHAT'S IN THE BOX

- LINX display screen
- LINX controller
- USB charge cable
- 3 x wiring looms
- LINX gimbal mount
- Quick start guide
- Display screen protector (polarizer compatible)



▲ AIR BAG ISOLATION KIT  
(7450109)



▲ PRESSURE CONTROL KIT  
(7450107)



LINX is a unique modern controller that declutters the dashboard and centralizes the command of vehicle accessories by replacing classic switches, gauges and monitors with one sleek and smart driver interface. Built on an expandable platform, LINX will continue to evolve your on and off-road experience both now and into the future.

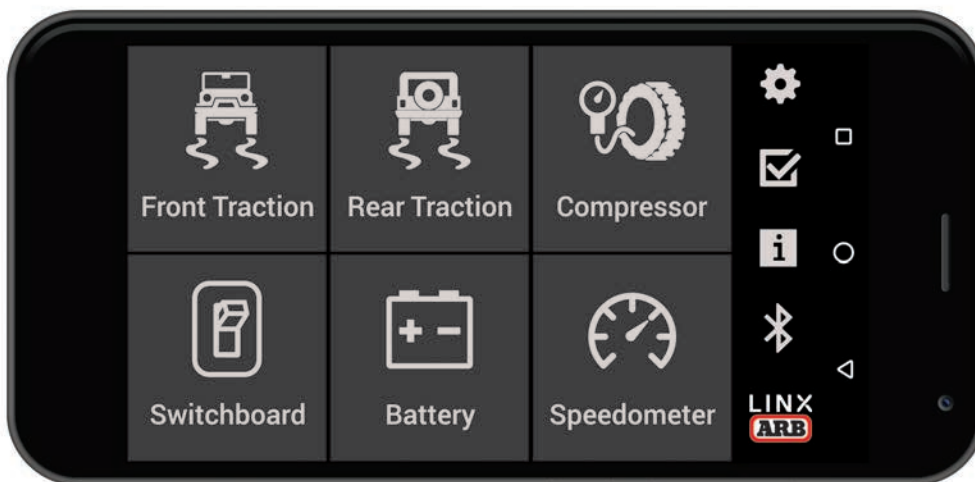

The LINX touchscreen display mounts conveniently and unobtrusively within reach of the driver while the main control hub lies neatly out of sight under the dash or seat taking care of all accessory wiring.





# AIR LOCKERS<sup>®</sup>



## THE REQUIREMENT

Many people believe that four-wheel drive and traction go hand in hand—you can't have one without the other. However, your vehicle's standard (or open) differential is designed to allow each wheel to turn independently, thus eliminating binding during turns. Off-road, this becomes a major burden as engine power will take the path of least resistance, which occurs at the wheels with little or no traction. Newer vehicles with limited-slip differentials may offer some improvement, but more often than not you'll find the slipping is not 'limited' enough to maintain forward progress. Automatic locking differentials also have their disadvantages. Aside from being noisy when disengaging, they can also upset the on road driving characteristics of your vehicle.

## THE SOLUTION

Created to provide 100% traction on demand, without sacrificing any of your vehicle's highway driving performance, ARB Air Lockers® employ a 12V or 24V air compressor designed to activate (and deactivate) a solid and durable locking mechanism inside the differential. This gives you the traction you need, when you need it, happening all at the flick of a switch, and all within the safety and comfort of the driver's seat.

The advantage of ARB Air Lockers® lies in the pneumatically operated locking system, that when activated, prevents the differential gears from rotating and therefore prevents the axle shafts from turning independently of each other.

With both wheels tied directly to the rotation of the ring gear, the vehicle maintains maximum possible traction at all times. When unlocked, it provides all the safety and predictability of a conventional 'open' differential.

In addition to providing outright improvements to a 4x4's off-road capabilities, an Air Locker® offers significant environmental benefits. An Air Locker® equipped vehicle can be driven in a slower, safer, and more controlled manner, greatly reducing the likelihood of vehicle damage and environmental impact.

## RANGE & INSTALLATION

Air Lockers® are currently available in over 100 configurations to suit a wide range of 4x4 vehicles from around the world, and can be installed in both the front and rear axles. Installation should be performed by a qualified differential technician to ensure optimal performance. ARB also offers three compressor models suitable for Air Locker® operation, two of which can also be used to inflate tires and other equipment.

For total peace of mind, all ARB Air Lockers® are backed by a comprehensive, five-year, unlimited mile warranty.



### Clutch Gear

ARB's patented locking system actually supports the side gear teeth, giving you more torque handling capability, exactly when you need it.

### Pinion Gear

Combining the strength of forged nickel alloy steel with redefined gear tooth geometry, ARB has revolutionized locking differential gear design to yield structural advantages of up to 30% over commercially available high strength gears.

### Cross Shaft Retaining Pin

Custom made one-piece hardened retaining pins lock into the assembly using a tapered thread junction.

### Flange Cap Assembly

Fully machined nodular iron flange cap incorporates the stationary side of ARB's tough, proven, and patented timed locking mechanism.

### Bonded Seal

Steel reinforced, elastomer-bonded annular seal has been proven to handle 20,000+ cycles under the most extreme climatic temperatures.

### Two-Piece Design

Machining a case from two-pieces instead of three results in a much higher dimensional accuracy of the finished assembly and has allowed ARB Engineers to improve the design of other elements, resulting in a reduction of moving parts, increased strength, and a more responsive activation.

### Air Supply

Activated using a dash mounted switch, compressed air is delivered to the seal housing assembly via a nylon airline.

### Spline Side Gear

High-grade surface treatments, forged nickel alloy steel, and ARB's patented timed locking system make this the most 'lockable' gear in the industry.

### Forged Gears

With phenomenal forces being applied to the side and pinion gears within the differential, ARB has invested heavily in the application of forged gears, typically found in heavy-duty commercial, race, and agricultural transmissions.

### Spider Block

A billet-machined alloy steel spider block supports the cross shafts, using the torque applied at each shaft to support the next shaft along.

### Long Cross Shaft

Alloy steel and performance surface technology make for a high-pressure running fit that can handle an enormous amount of punishment.

### Return Spring

Instead of a complex external actuator system to engage/disengage the locking mechanism, ARB Air Lockers® use a unique wave spring to support the entire profile of the locking gear for a fast, positive, and independent disengagement.

### Diff Case

Fully machined one-piece nodular iron diff carrier case offers the rigidity of a one-piece factory differential with twice the standard number of pinion gears to cope with the torque.

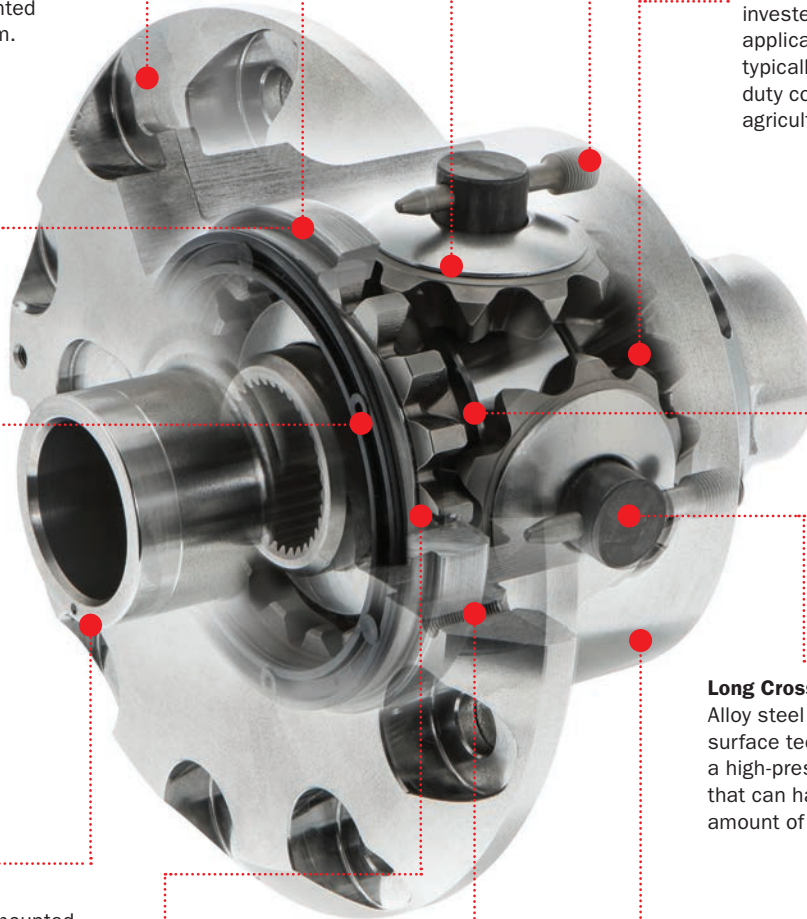

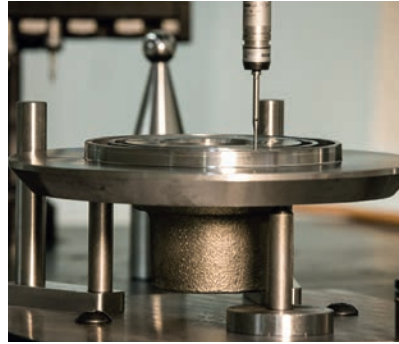

## ENGINEERING & TESTING

The design process of an Air Locker® involves countless hours of testing. Computerized Finite Element Analysis (FEA) allows the engineer to subject each Air Locker® to 'virtual' off-road driving stress simulations far greater than those experienced in real life, including extreme temperatures and harsh wheel spin. Prototypes are tested to ensure the strength of the Air Locker® exceeds that of the axles or other driveline components. Finally, field testing is carried out with units being fitted to four-wheel drive vehicles that operate in the harshest environments imaginable.

## MANUFACTURING & ASSEMBLY

ARB has a highly skilled and motivated workforce operating in its manufacturing plants. Our dedicated employees, many of whom are off-road enthusiasts, maintain a very high standard of workmanship throughout the assembly and distribution process. We have stringent quality and environmental control systems in place, ensuring our exceptionally high standards are maintained. Air Lockers® are manufactured in ARB's state-of-the-art facility in Melbourne, Australia and sold throughout the world.

## AFTER SALES SERVICE

For total peace of mind, all ARB Air Lockers® are backed by a comprehensive, five-year, unlimited mile warranty. Coupled with ARB's extensive distributors and authorized dealers, you can be sure we'll be there to support you in the unlikely event of an issue.



## PERFORMANCE MODEL RANGE

Of the many ARB products seen in off-road competition, it's the one you can't see that makes the difference. ARB Air Lockers® continue to dominate the world's toughest off-road events, providing the perfect proving ground for our range of performance models.

Used by some of the biggest names in off-road competition, Air Lockers® are just as at home plugging through mud or scaling near vertical rock ledges as they are on your daily driver. These guys stake their reputations on quality and reliability. If they can trust Air Lockers® to get them across the finish line, then you can be sure they'll survive anything you throw at them off-road.



## ▲ DIFFERENTIAL COVERS

An ARB Differential Cover will protect your differential against the hazards of competition or extreme off-road use.

When off-road, it is inevitable that obstacles and off-road hazards will be encountered that could potentially inflict expensive damage to your differential. To prevent this, ARB manufactures a range of differential covers. Using high-tensile nodular iron, they are engineered to protect the differential and ring and pinion set from any off-road hazards.

Differential covers are perfect for both competition and off-roading where harsh off-road work can be encountered. Coming in a red or black powder coat finish, ARB Differential Covers are available to suit a select range of differentials.

## FEATURES

- Computer-optimized cross brace design increases the structural rigidity of the whole axle
- Additional housing strength helps keep the ring and pinion gears meshing on the flat faces of the teeth, greatly increasing ring and pinion life and overall maximum load strength
- Top quality, high-power neodymium magnets are used in both the drain plug and the dipstick to collect metallic wear particles as the vehicle moves
- Magnet location in the end of the dipstick allows the oil to be checked for telltale signs of internal damage
- Prolonged carrier bearing life due to extra support to the bearing alignment
- Approach/departure angle optimized by angled exterior surfaces
- Unique dipstick/filler cap design allows the differential oil level to be adjusted for customized high driveline angles



## ▲ DIFFERENTIAL BREATHER KIT (170112)

When drivetrain assemblies such as your vehicle's differentials, gearbox, and transfer case heat up under normal operation, the air inside expands and increases pressure. To vent this additional pressure, most factory differentials have a valve mounted to either the assembly itself, or on a short extension tube close by.

Unfortunately, when the drivetrain assembly cools down, the air inside contracts, creating a vacuum. When cooling occurs during a water crossing, these valves can draw water into the system, potentially causing expensive damage.

The ARB Differential Breather Kit is designed to provide a high-flow, zero-back pressure, zero-vacuum breather system to keep your drivetrain free of water. This is achieved with a central high-flow air filter and manifold that will allow up to four drivetrain assemblies to be vented to one central location, positioned high enough to avoid water during crossings.





**4X4 ACCESSORIES**

# **AIR COMPRESSORS & AIR SYSTEMS**

# AIR COMPRESSORS

AVAILABLE IN BOTH PORTABLE AND VEHICLE-MOUNTED KITS, ARB AIR COMPRESSORS PROVIDE MANY ADVANTAGES FOR EXPLORING THE GREAT OUTDOORS.

Whether inflating tires and camping accessories, running air tools, activating Air Lockers® or even reseating a tire onto a wheel, there's a model available to fit your needs. All ARB Air Compressors come with a comprehensive two-year warranty and are individually leak, current draw, and flow tested under load at the factory before packing.



APPROX. INFLATION TIME (MINUTES/TIRE)	Tire Size	0-30psi	15-30psi
	31x10.5R15		2:34
33x12.5R15		3:53	1:45
35x12.5R15		5:15	3:00

## HIGH OUTPUT COMPRESSOR (CKMA12/24)

### FEATURES

- Sealed for moisture and dust resistance
- Hard anodized cylinder bore for reduced friction
- Teflon-impregnated carbon fiber piston seal for maximum trouble-free life
- Anodized mounting bracket dissipates motor heat and allows compressor to be rotated 180 degrees on vehicle-mounted models
- On-board model available in either a 12V or 24V configuration
- Quality components for quiet operation and extra long life
- Constructed entirely of lightweight, high strength, engineering grade materials
- Over-pressure safety valve equipped
- Motor is thermally protected against extreme temperature damage
- Heavy-duty maxi-fuse equipped for professional in-line circuit protection



APPROX. INFLATION TIME (MINUTES/TIRE)	Tire Size	0-30psi	15-30psi
	33x12.5R15		2:06
35x12.5R15		2:18	1:00
37x12.5R17		2:47	1:40

## MAXIMUM PERFORMANCE COMPRESSOR (CKMTA12/24)

### FEATURES

- Designed for inflating tires and Air Locker® activation when used in conjunction with optional accessories
- Suitable for many air tools when used in conjunction with one-gallon air tank (optional with on-board models)
- 100% duty cycle
- Sealed for moisture and dust resistance
- Hard anodized cylinder bores for reduced friction
- Teflon impregnated carbon fiber piston seals for maximum trouble-free life
- Anodized mounting bracket dissipates heat
- Integrated pressure switch, relays and IP55 (waterproof/dustproof) brushless fan cools electronics, motors and cylinder heads
- Over-pressure safety valve equipped
- On-board model available in either a 12V or 24V configuration

# PORTABLE AIR

ENGINEERED TO SUIT ANY OFF-ROAD ADVENTURE, ARB PORTABLE COMPRESSORS COME COMPLETE WITH A 20FT AIR HOSE, INFLATION KIT, BATTERY CLIPS, HARD MOUNTED ACTIVATION SWITCH, AND PROFESSIONAL CIRCUIT PROTECTION.

Available in either High Output or Maximum Performance, each kit is housed in a durable carry case for protection and practicality.



## ▲ HIGH OUTPUT PORTABLE (CKMP12)

For easy carrying and storage, this portable air compressor is constructed from lightweight, high-grade materials and comes mounted in a durable case.

## ▲ MAXIMUM PERFORMANCE PORTABLE (CKMTP12)

For high-flow air on-demand, the maximum performance portable air compressor is an ideal solution for air tools, inflating tires and camping or leisure gear.

Model	Desc.	Supply Voltage	Current Draw No Load	Air Flow Under No Load		Current Draw Under Load	Air Flow Under Load		Weight (Compressor and Accessories)		Duty Cycle % at 72 F (on time/off time)	Size When Positioned Vertically In The Mounting Bracket			Automotive Lead Protection In Loop	Air Locker Solenoid Mounting Manifold	Pressure Cutout Switch	Air Filter Equipped	20 Ft. Tire Inflation Hose	Thermal Overload Protected Motor
				@ 0Kpa	@ 0PSI		@ 200Kpa	@ 29PSI	Kgs	Lbs		H	L	W						
CKMP12	High Output Portable	12	14A	87.2L/m	3.08CFM	25A	66L/m	2.34CFM	6.6	14.5	50% 30/30	8.2"	17.3"	9.4"	●	●	●	●	●	
CKMTP12	Max Performance Portable	12	28A	174.4L/m	6.16CFM	50A	132L/m	4.68CFM	15	33	100% 60/0	7.3"	18.8"	14"	●	●	●	●	●	

# ON-BOARD AIR

PERMANENTLY MOUNTED, THE RANGE OF ARB ON-BOARD AIR COMPRESSORS ARE WATER, DUST, HEAT, AND SHOCK RESISTANT TO WITHSTAND THE RIGOURS OF OFF-ROAD TRAVEL.

Each kit includes a full wiring harness with relay, multi-position mounting bracket, and pressure switch. An optional tire inflation kit is also available separately for certain models.



## ▲ HIGH OUTPUT COMPRESSOR (CKMA12/24)

Permanently mounted and designed to withstand harsh environments, this compressor can be used to activate Air Lockers®, as well as inflating tires and other equipment.



## ▲ MAXIMUM PERFORMANCE (CKMTA12/24)

For optimum power and maximum performance, the twin motor design will deliver superior air flow for fast inflation.



## ▲ AIR LOCKER® ACTIVATION SYSTEM (CKSA12)

Specifically designed to activate ARB Air Lockers®, this smaller unit is sealed for moisture and dust resistance, allowing versatile positioning and proper performance.

Model	Desc.	Supply Voltage	Current Draw No Load	Air Flow Under No Load		Current Draw Under Load	Air Flow Under Load		Weight (Compressor and Accessories)		Duty Cycle % at 72 F (on time/off time)	Size When Positioned Vertically In The Mounting Bracket			Automotive Load Protection In Loom	Air Locker Solenoid Mounting Manifold	Pressure Cutout Switch	Air Filter Equipped	20 Ft. Tire Inflation Hose	Thermal Overload Protected Motor
				@ 0Kpa	@ 0PSI		@ 200Kpa	@ 29PSI	Kgs	Lbs		H	L	W						
CKSA12	AirLocker Activation System	12	5.5A	27.7L/m	0.98CFM	7.5A	19.7L/m	0.70CFM	2.4	15.3	35% 21/39	4.8"	6.4"	3.5"	●	●	●			
CKMA12	High Output On-Board	12	14A	87.2L/m	3.08CFM	25A	66L/m	2.34CFM	4.5	9.9	50% 30/30	5.7"	7.5"	3.9"	●	●	●	●	●	
CKMTA12	High Output Portable	12	28A	174.4L/m	6.16CFM	50A	132L/m	4.68CFM	8.8	19.4	100% 60/0	4.1"	10.9"	7.5"	●	●	●	●	●	



# AIR ACCESSORIES

THE AIR SYSTEMS RANGE COMBINES A HOST OF ARB'S PROVEN AIR-RELATED ACCESSORIES WITH A NEW RANGE OF COMPONENTS DESIGNED TO PROVIDE AN ALL-IN-ONE SOLUTION FOR EQUIPPING A VEHICLE FRONT TO BACK WITH ON-BOARD AIR.



## AIR SYSTEMS COMPONENTS

Air Systems components, such as air fittings, various lengths of stainless braided PTFE hose, and air chuck mounting solutions, provide all the necessary components to fit a complete air compressor system to your four-wheel drive, essentially allowing a vehicle to be outfitted front to back with on-demand air.



## PUMP UP KIT (171302)

Standard on the portable compressor kits, the pump up kit is also an optional accessory for the vehicle-mounted range. Incorporating quick connect couplings for quick mounting to ARB Air Compressors and accessories, the kit also includes a quality 20ft air hose, an air accessory kit, and a T-piece for inline connection of an air chuck and pressure switch.



## AIR LOCKER® MANIFOLD KIT (171503)

Designed to work seamlessly with ARB's Maximum Performance On-Board Compressors, the Air Locker® manifold kit enables easy installation of Air Locker® solenoids to an air source. With a working pressure of 150PSI (1030kPa), the manifold kit incorporates multiple ports for use with ARB's Pump Up Kit, as well as mounting brackets, and a Teflon stainless steel braided hose designed to cool air supply for tire inflation.



## ALUMINUM AIR TANK (171601)

Ideal for use with ARB's CKMTA High Output Air Compressors and rated to a maximum working pressure of 150PSI, the one-gallon aluminum air tank delivers high volume air output to aid in tire inflation and running most air powered tools. 50% lighter than an equivalent steel tank, the tank incorporates two 1/4NPT ports with JIC-4 male fittings and mounting hardware for easy integration.



## LARGE DIAL TIRE GAUGE (ARB508)

Designed for off-road use, this gauge incorporates a lower scale for improved accuracy at lower pressures. Simple to use with a large 3.5" diameter gauge and three pressure scales (PSI, kPa and bar). Quality bronze Bourdon Tube gauge ensures accuracy is not affected by changes in temperature, humidity or altitude. Flexible hose with dual chuck for all rim and valve types.



## SMALL DIAL TIRE GAUGE (ARB506)

This tire gauge is the ideal way to accurately measure your tires' PSI when you're making adjustments for off-road conditions. A fully geared, solid brass precision movement and Bourdon Tube gauge with flexible hose means easy access for rims with intricate styling.

# TIRE ACCESSORIES



## ◀ DIGITAL TIRE INFLATOR (ARB601)

It's important to carry accurate air pressure equipment in your vehicle, especially when traveling off-road. The ARB Digital Tire Inflator makes checking and adjusting tire pressure easy, with its large, easy to read backlit display, thumb operated inflator lever and easy access deflator bleed button.



▲ **TIRE PRESSURE MONITORING SYSTEMS**  
**(INTERNAL - 819100)**  
**(EXTERNAL - 819101)**

ARBS offers customers a range of tire pressure monitoring systems (TPMS) that are easy to install and operate. ARBS's TPMS is available in either a DIY external sensor kit, or internal valve replacement kit, both of which feature a small 12V operated display that shows all four tire pressures in real time, detecting any punctures or high temperatures. Additional features include a 5V/1A USB port for charging other devices without removing the TPMS unit from the socket. Also available is the ARBS Sensor Partner, an optional accessory, which pairs internal sensors to the display when the position of the tire is changed.

▶ **E-Z TIRE DEFLATOR**  
**(ARB505)**

The unique, patented design of the E-Z Deflator allows for removal of the valve core for rapid tire deflation, while also providing accurate tire reading via the simple movement of a sliding valve.

**FEATURES**

- Corrosion resistant brass/stainless deflator tool
- Bronze Bourdon Tube gauge design ensures accuracy is not affected by changes in temperature, humidity or altitude
- Fully geared, solid brass precision movement
- Protective rubber gauge guard
- Easy to read dial with 1PSI increments
- Designed and thoroughly tested to ensure accuracy
- Includes protective canvas pouch and instruction sheet



▲ **SPEEDY SEAL TIRE REPAIR KIT**  
**(10000011)**

Coming in a compact carry case, the Speedy Seal includes all of the components necessary to repair tubeless radial or cross-ply tires, without removing the tire from the vehicle or rim.







**4X4 ACCESSORIES**

# ROOF RACKS



# ROOF RACKS

Precision-cut drainage channel, specifically designed to reduce build up of dirt and accumulation of moisture.

Top rail sits well above rack floor to ensure a secure load and is constructed from tough, 25mm tube while the bottom rail utilizes 35mm tubing.

**Steel Specific**  
Evenly spaced crossbars can support loads of up to 330lbs, with an optional fully welded steel mesh floor also available.

Full length, zinc annealed steel support channel with plastic protection strip to distribute load along the gutter and prevent vehicle damage.

Stainless steel fitting hardware and a unique, super-strong clamping system that's easy to install and remove.

**Steel Specific**  
MIG welding is used on the joints to ensure optimum strength.

Pressed steel feet and legs are height and width adjustable, allowing multi-vehicle installations.



## STEEL

With a strong, aerodynamic design, ARB's Steel Roof Racks are constructed for maximum strength and perfectly suited to the structural design and load carrying requirements of off-roading.

**EXTENSIVE RESEARCH, DESIGN AND TESTING GOES INTO ALL ARB ROOF RACKS TO ENSURE THEIR FUNCTIONALITY IS NEVER COMPROMISED, EVEN UNDER THE MOST DEMANDING CONDITIONS.**

**Aluminum Specific**

An Amplimesh alloy mesh floor comes standard on the Aluminum Series, which is used to ensure the optimum strength of each rack.

**Aluminum Specific**

A combination of TIG and the acclaimed Cold Metal Transfer (CMT) welding process is used to ensure the optimum strength of each rack.

Rails are mandrel formed, ensuring consistency and even wall thickness across all sections.

Air deflector plate significantly reduces wind noise.



## **ALUMINUM**

Lightweight, the Aluminum Series is the ideal solution for carrying excess or bulky items, with all of the durability, strength and load rating of an ARB Steel Rack. It is also perfectly suited to owners who may wish to remove their rack between trips.





# ROOF RACK OPTIONS



## ▲ CAB RACKS

ARB's Steel Cab Racks provide up to 165lbs of carrying capacity with a shorter length in order to accommodate the smaller roof area on dual cab vehicles.



## ▲ TOURING RACKS

Specifically designed to mount the ARB Rooftop Tent range, this high quality manufactured steel roof rack is suitable for both rooftop tent mounting and front section storage.



## ▲ FLAT RACKS

Flat Racks provide added mounting versatility and the practicality of a flat roof rack platform, maximizing clearance when not in use.



## ▲ MESH FLOOR

Providing further versatility to the ARB Steel Roof Rack range, a fully-welded steel mesh floor can be fitted to offer further support for your roof rack storage.





**4X4 ACCESSORIES**

# **STORAGE SOLUTIONS**



# OUTBACK SOLUTIONS MODULAR ROLLER DRAWER SYSTEMS

Modular units allow greater flexibility if your needs change in the future.

Purpose folded stainless steel runners for smooth drawer and slide operation.

Long lasting, UV stable commercial carpet designed to complement modern vehicle interiors.



Vehicle-specific side floor kits complete installation and reduce redundant areas within the cabin.

Cross-folded floor ensures maximum support for items placed within each unit.

Self-locking anti-rollback system locks into place at full extension, removing the need for locking pins.

Key lockable, push-pull slam shut latches for ease of use and maximum security.



**WITH A SLEEK MODERN DESIGN AND HIGH QUALITY COMPONENTS THAT CAN BE TAILORED TO YOUR INDIVIDUAL NEEDS, THE OUTBACK SOLUTIONS RANGE REDUCES REDUNDANT AREAS WHILE PROVIDING INCREASED STORAGE.**

The Outback Solutions Modular Drawer Systems range comprises of a simple bolt-together-assembly and comes in three types of modules; roller drawer, roller drawer with roller floor, and roller floor. All modules come in a range of sizes and can be mixed and matched to suit more than 200 possible configurations.

The fully interchangeable modules can be mounted side by side, stacked, easily removed, swapped, or added depending on your changing requirements.

Whether you need to carry an ARB Fridge Freezer, tools, or the kids' toys on your next off-road adventure, there is an option to suit your requirements. The Outback Solutions range is backed by a comprehensive two-year warranty.



▲ **TWO STANDARD DRAWERS (LEFT & RIGHT)**



▲ **STANDARD DRAWERS STACK (LEFT & RIGHT)**



▲ **ROLLER FLOOR**



▲ **TWO ROLLER FLOORS**



▲ **ROLLER FLOOR DRAWER (L) STANDARD DRAWER STACK (R)**



▲ **DRAWER ACCESSORIES AVAILABLE**



**4X4 ACCESSORIES**

# PERFORMANCE LIGHTING





# INTENSITY LED DRIVING LIGHTS

ENGINEERED IN AUSTRALIA AND MANUFACTURED IN THE USA, THE ARB INTENSITY LED LIGHT RANGE DELIVERS OUTSTANDING PERFORMANCE IN ALL CONDITIONS.



Available in a spot or flood beam (model dependent), Intensity LED driving lights and Intensity light bars are vastly more efficient than traditional halogen lamps, producing a white light that simulates sunlight. This reduces eyestrain and driver fatigue, while also performing brilliantly on corrugated roads by producing a broad field of light that helps diffuse visible vibration.

The lights feature an ARB-engineered heatsink with numerous fins to help prevent heat damage to the LEDs and surrounding components. The heatsink also ensures the LED circuits run cooler and produce an optimum light output while extending the light's longevity.

ARB Intensity LED Lights are engineered to withstand long periods of extreme conditions and are vibration certified to

military standards, dust and waterproof to IP68 rating, and are water submersible to 9ft.

ARB Intensity LED Driving Lights are available in two sizes, both boasting 50,000+ hour lifespan. The AR32 model features 32 LEDs and the AR21 model has 21 LEDs. The AR21 was developed as an alternative for drivers with smaller bumpers where the AR32 could not be mounted.

ARB's innovative Intensity light bar has been designed for integrated fitment to the complete range of ARB Bumpers. With 40 highly focused LEDs, the light bar completes ARB's Intensity Light range, providing you with the best possible light source for safe night-time driving.



# AR32 & AR21

## AR32

Available in spot and flood beams, and featuring 32 LEDs with 50,000+ hour lifespan.

## AR21

Featuring 21 LEDs, with a 50,000+ hour lifespan, the AR21 is available in spot and flood beam.

A GORE-TEX® breather acts as a vent to protect against condensation and contaminants.

Hard-coated, durable protective cover offers an additional shield against potential damage while off-roading.

Virtually indestructible polycarbonate lens provides protection against road debris.

High-pressure cast aluminum body for superior strength.

Protected against radio frequency (RFI) and electromagnetic (EMC) interference, the lights are also MIL810-STDG vibration certified and RoHS compliant.

Over and under voltage protection and integrated thermal management for optimal operation.

Deutsch DT06 waterproof connectors.

Multi-position stainless steel mounting bracket features a large footprint, versatile installation options, and a TIG weld for added strength.



# AR40 INTENSITY LED LIGHT BAR

ARB'S AR40 LIGHT BAR IS AVAILABLE IN A SPORT OR COMBINATION BEAM, AND FEATURES 40 LEDS WITH A 50,000+ HOUR LIFESPAN.

Virtually indestructible polycarbonate lens provides protection against road debris.

Large, extruded aluminum body provides superior strength and acts as a heatsink to draw heat generated by the electronics away from the LED array, increasing the efficiency and life of the LEDs.

A unique molded rubber seal between the polycarbonate lens and aluminum body provides a watertight and dustproof seal, allowing the light to achieve IP68 rating and submersion up to 9ft.

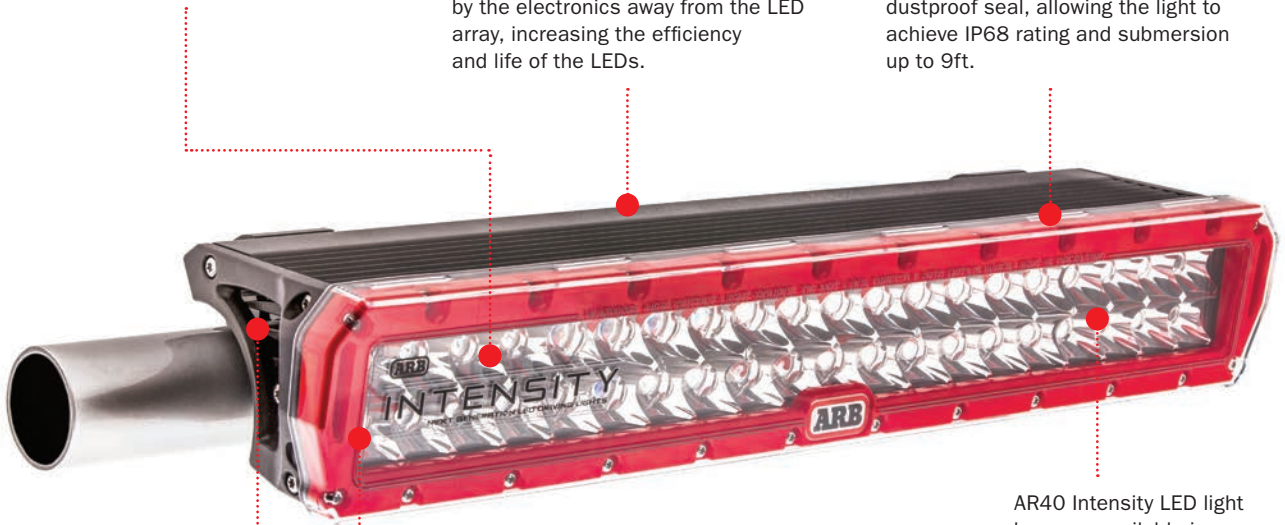

AR40 Intensity LED light bars are available in either a spot or combo beam to suit individual requirements.

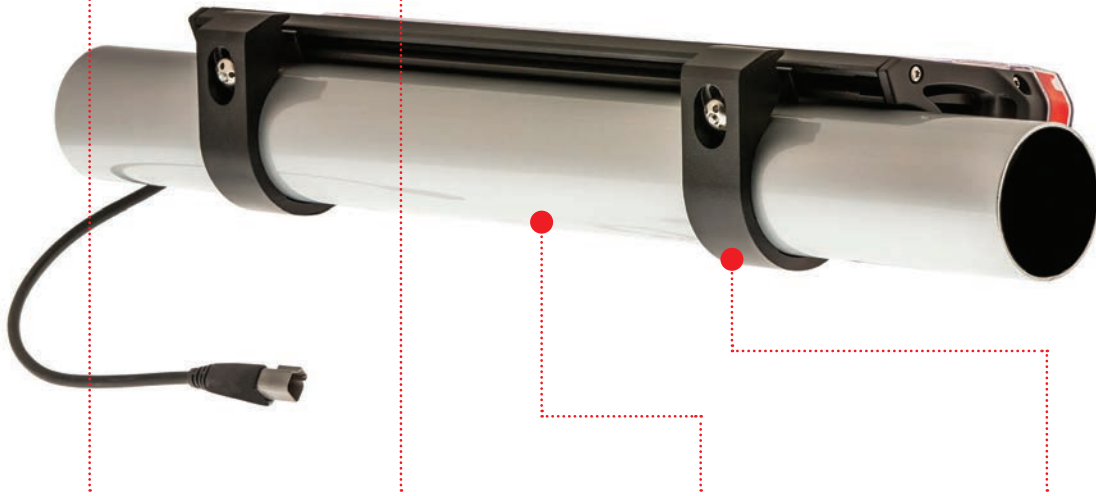

High-pressure cast aluminum end caps contain a GORE-TEX® breather, enabling expansion and contraction of internal air during temperature fluctuations, without allowing water or dust ingress.

Over and under voltage protection and integrated thermal management for optimal operation.

Different mounting kits are available to suit a number of tube diameters, designed to specifically fit ARB Bumpers.

Each light is secured to the vehicle with an ARB Tamper Proof Fastener. On the tube mounting kits, all fasteners are recessed within the clamp for increased security.

# LIGHTING ACCESSORIES

Along with driving lights, a variety of other products including fog lights, headlight inserts and a complete range of lighting accessories are also available to suit your individual needs.

## ACCESSORIES INCLUDE

- ARB Intensity LED Light Covers
- ARB Wiring Looms
- ARB Wiring Loom Extension
- Lock Nuts and Light Stays

### ▶ INTENSITY LED DRIVING LIGHT COVERS

- (AR09 - CLEAR COVER)
- (AR09TR - RED COVER)
- (AR09SB - BLACK COVER)
- (AR09TA - AMBER COVER)
- (AR09TB - BLUE COVER)

An ARB Light Cover is essential to protect your ARB Intensity Driving Light. Manufactured from polycarbonate and hard coated for scratch and UV resistance, these covers will protect your Intensity driving light from the elements.



### ◀ INTENSITY LED LIGHT BAR COVERS

- (AR11 - CLEAR COVER)
- (AR11TR - RED COVER)
- (AR11SB - BLACK COVER)
- (AR11TA - AMBER COVER)
- (AR11TB - BLUE COVER)

An ARB Light Cover is essential to protect your ARB Intensity Light Bar investment. Manufactured from polycarbonate and hard coated for scratch and UV resistance, these covers will protect your Intensity light bar from the elements.

### INTENSITY LIGHT WIRING KIT

- (3500810 - WIRING LOOM)
- (3500820 - LOOM EXTENSION)

ARB Intensity Lighting installation is made easy with high quality wiring looms incorporating waterproof Deutsch connectors, heavy-duty relays, and all necessary mounting hardware. Also available is an extension loom for the AR40 which is ideal for when installed on the roof of the vehicle or further than the usual install kit allows.



**4X4 ACCESSORIES**

# TENTS, AWNINGS & CAMPING





# ROOFTOP TENTS

AN ARB ROOFTOP TENT WILL PROVIDE THE ULTIMATE IN EASE AND CONVENIENCE WHEN TRAVELING.



Mounted to the roof of a vehicle and unfolding in minutes, a rooftop tent keeps your sleeping quarters off the ground and protected from the elements.

Ideal for your next camping trip away, the Simpson III Rooftop Tent means sleep-easy camping. Not only is it spacious and comfortable, but all bedding can remain inside the tent during the journey, freeing up vital storage space in the vehicle. This also allows for fast setup. Simply fold the tent, slip on the cover and drive away.

With the ability to be mounted using ARB's purpose designed roof rack or a suitable flat rack system, the Simpson III Tent can be mounted on a number of different angles for optimum versatility.

The included zip-on annex for the Simpson III provides additional space and storage and has enough room to fit two cots without obstructing access to the rooftop sleeping area. Storm flaps are incorporated into the annex and fold inward to eliminate water ingress, with the option for individuals to add their own floor if they wish.



▲  
**SIMPSON III ROOFTOP TENT  
 (803804)**

Our high quality Simpson III Rooftop Tent is packed with features for extra comfort when camping. The pull-out veranda and included annex provide added space and protection from the elements, as well as offering total privacy when climbing in and out of the tent.

**FEATURES**

- Manufactured from high quality, poly/cotton ripstop canvas with polyurethane coating for excellent waterproofing
- Incorporates Oxford Polyester flysheet with optimum water shedding ability
- Sturdy retractable aluminum ladder
- High-density bonded chip foam mattress with removable cover
- Pull-out veranda and zip-on annex
- Insect screened windows and doors
- UV stabilized laminated PVC cover
- Bungee cord system to assist when closing
- Size: 7.8ft (L) x 4.5ft (W) x 4.25ft (H)
- Easily mounted to an ARB Roof Rack or any flat mounting surface

# SKYDOME SWAGS



ARB's SkyDome Swag range provides a versatile, comfortable and convenient camping option when traveling off-road.

With a unique dome shape, the SkyDome provides a spacious interior that offers room to stretch out after a long day on the road.

The generous length, width and height of the swag provides much-needed space from head to toe, eliminating the often claustrophobic feeling of a traditional swag and allowing you to relax, bend your knees, or sit up in the SkyDome.

The freestanding design of the swag ensures it can be conveniently placed on any flat surface without having to rely on pegs and guy ropes.

This allows the swag to be set up on sand, rock or even concrete, while the corrugated foam mattress provides comfort on any surface.

Outstanding in wet conditions, the SkyDome features a heavy-duty PVC base with welded seams, making it fully waterproof. Extending up the side of the swag, the waterproof base further prevents water leakage from puddles or mild flooding while the SkyDome's heavy-duty canvas top is also waterproofed.

Tested in the Outback, the SkyDome Swag is available in a single or double configuration to suit the various requirements of travellers.





▲  
**MESH MULTI-MAT**  
**(813404)**

The ARB Mesh Multi-Mat provides extra comfort when exploring the great outdoors and is created from a heavy-duty mesh to protect your belongings from the harsh elements. Compatible with an ARB SkyDome Swag and ARB Awnings, the mesh multi-mat has eyelets that are specifically placed to accommodate swag and awning poles, with additional perimeter peg down points for secure placement. The mesh multi-mat can also be used as a shade sail, providing protection from the sun.

▼  
**SWAG BAGS**  
**(SINGLE - 10100385)**  
**(DOUBLE - 10100390)**

Developed specifically for storage and transit of the ARB SkyDome Swags, these bags feature molded rubber carry handles on either end, along with a removable shoulder strap. Unique to the swag bag is four adjustable tie down straps integrated into the bag that allow it to be secured to a roof rack without the need for additional straps.



# SKYDOME SWAGS

Head awning with wide brim hat holder is accessible from inside or outside the swag.

Freestanding dome design incorporates heavy-duty 450gsm water and rot proofed canvas, tested to Australian standards.

Large sleeping area measuring 7ft (L) x 4.5ft (W) for the double swag and 7ft (L) x 3ft (W) for the single.



Head and foot awnings feature multiple attachment points for reflective guy ropes and a solid support bar for reduced movement in windy conditions. External awnings provide protection in foul weather, while zippered internal head and foot storm flaps reduce dust entry.

Nickel-plated brass eyelets for corrosion protection, and durable, elasticised 11mm aluminum bows for easy assembly and storage.

Two internal, high-mount hooks and Velcro holder suitable for items such as an ARB Adventure Light, lamps and keys, plus four integrated internal accessory pockets for storage of items such as a phone, wallet and water bottle.

Large entry with nylon mesh door provides easy access, excellent ventilation, and exceptional view of the night sky. All doors and windows feature YKK zippers, while a rain gutter is incorporated into the main entry door to inhibit water ingress.



Comfortable 3" corrugated foam mattress with anti-microbial additives and a non-rustling, machine washable cover.

Waterproof heavy-duty 820gsm PVC base with 3" high return protects against water ingress and the welded corners and PVC anchor tabs prevent water wicking through seams.

# AWNINGS



Easy to mount and operate, these retractable awnings fit onto the side of most roof racks and store neatly in a PVC bag or sturdy aluminum case for immediate use on arrival.

Specifically designed for harsh off-road conditions and coming complete with hardware and comprehensive instructions, each awning is rugged, yet lightweight, and will provide fast, convenient shade and protection from the elements.

## FEATURES

- Size: 8ft, 6.5ft or 4ft long extends out to either 7ft or 8ft wide
- Self standing awning takes 30 seconds to deploy
- Manufactured from lightweight PU coated 300gsm poly/cotton canvas
- Waterproof & UV protected with a UVP 50+ rating
- Awning secured in UV stable laminated PVC bag or aluminum case
- Awning height adjustable with telescopic legs
- Guy ropes and pegs supplied for windy conditions



▲  
**DELUXE AWNING ROOM WITH FLOOR**  
**(813208A - 2000MM X 2500MM)**  
**(813108A - 2500MM X 2500MM)**

The deluxe awning room with floor provides protection from the weather and insects, as well as additional privacy when camping and can be used as a fully enclosed room or mosquito net. Incorporating zipper operated two way solid and mesh access doors, the awning room is easy and quick to set up and can be used with 8ft and 6.5ft ARB Awnings.

**FEATURES**

- Exterior walls are made from UV treated Oxford Polyester with ultra-fine insect mesh
- Heavy-duty, bucket style polyethylene waterproof floor with heat taped seams
- Removable internal organizer pockets
- Supplied with hardened steel pegs and guy ropes
- High-mounted cable access ports for cable guides and lighting solutions
- Heavy-duty hooks for awning pole attachment



## ▲ ALUMINUM AWNING (814102A)

ARB's aluminium encased awning offers a sleek and contemporary alternative to traditional awning covers while adding improved functionality.

The three quick release bungee cords and flip-up lid provide unmatched simplicity for unpacking and setup. Inside is our proven 300gsm, PU coated, fully waterproofed and UV protected canvas to ensure your protection from both the sun and rain.

The awning is supported by heavy duty 1.2mm gauge x 25mm diameter expandable aluminium poles, anodized for greater corrosion resistance and perfect for setting up by the beach.

### FEATURES

- Size: 2500mm x 2500mm
- Ripstop canvas, a cross-hatched design, improves strength
- Metal cam locks
- Includes pegs and reflective guy ropes
- Compatible with awning rooms and mesh multi mat

# AWNING ACCESSORIES



## ◀ QUICK RELEASE BRACKET

Quickly unbolt your awning for storage or move it to a different mounting place on your vehicle with the ARB Quick Release Awning Brackets. Engineered to mount to all ARB Awnings, these brackets with provide added versatility for all your off-road adventures.

## ▶ GUY ROPE SET & SUPERGRIP SAND PEGS (ARB4159 - GUY ROPE SET) (ARB4158 - SAND PEGS)

ARB's Guy Ropes and Supergrip Sand Pegs will ensure your camping gear are firmly planted in the ground. The guy ropes are available in a two pack and feature reflective sections for better visibility in low light and the supergrip sand pegs are available in a handy four pack.



# CAMPING ACCESSORIES



## CAMPING CHAIRS

(10500101A - ARB TOURING)

(10500111A - AIR LOCKER®)

(10500121 - OME BP-51)

Rated to 330lbs, ARB's range of camping chairs provides comfort and practicality around the campfire.

Featuring a convenient solid molded clip-on table, complete with drink holder, padded seat and backrest for extra comfort and mesh pockets to stash belongings, these handy chairs keep everything at arms reach.



## ADVENTURE LIGHT 600

(10500060A)

The next generation adventure light is here. Offering more power and more unique features, the ARB Adventure Light 600 will make your life easier when you're on a camping or fishing trip, off-road adventure, and even in the workshop. With handy hooks and magnetic mounts, the ARB Adventure Light 600 can be placed just about anywhere!

### FEATURES

- 6 hours of run time (low), 3 hours of run time (high)
- IP54 rating (dust protected, rain resistant)
- 600 lumen COB (chip on board) LED
- Rechargeable LI-ION battery
- Battery capacity display



## STORMPROOF BAGS

(10100300 - SMALL)

(10100330 - MEDIUM)

(10100350 - LARGE)

Stylish in design, ARB's Storm Bags come in three sizes and feature PU coated Oxford weave fabric and rubber construction, with all seams heat sealed and taped to ensure storm proofing. A roll up top closure and 'sure grip' buckles create a water resistant seal. Not only are they a good looking bag for travel, they are also 'storm proof' so they can be loaded onto a roof rack or thrown into the back of a truck without the worry of your gear getting wet.



4X4 ACCESSORIES

# FRIDGE FREEZERS





# ELEMENTS WEATHERPROOF FRIDGE FREEZER

Sealed, dimmable control panel controls all functions and displays important operating data including temperature and battery input voltage. For added security, the panel is partially covered with the lid closed, preventing unwanted tampering, and an electronic PIN lock keeps contents safe while unattended.

Unique gas strut holds the lid open in any position (from closed to upright), keeping both of your hands free to grab items from within.

Molded cover panels protect and cushion the edges of both the lid and the main body from knocks and bumps.

304 grade stainless steel exterior provides exceptional protection from the elements.



Anodized aluminum over-center latches keep the lid securely closed during off-road travel.

Provision for additional padlock security.

**ENGINEERED TO WITHSTAND THE HARSHTEST CONDITIONS, AND MADE TOUGH ENOUGH TO PERMANENTLY MOUNT IN THE BACK OF AN OPEN TRUCK BED, THE ELEMENTS FRIDGE FREEZER IS THE ULTIMATE OFF-ROADER'S FRIDGE.**

Heavy-duty, tamperproof cast stainless steel hinges offer exceptional strength and durability.

Recessed carry handles reduce overall length, taking up less space in the back of the vehicle.

Drain channel allows water to escape from the gas strut compartment.



Tamperproof bolts can be fitted to optional permanent mounting brackets.

Provision for recessed, optional remote fridge monitor transmitter.

**INTERNAL FEATURES**

- Full height evaporator surrounds both the main and secondary cabinets for increased temperature consistency
- Reversible basket with removable divider allows storage of larger items
- Slimline LED rear facing interior light
- Increased insulation thickness reduces runtime and power consumption
- Drain plug in the main cabinet allows easy cleaning and draining of spills

Staggered height, recessed power connections, and cable retention strap provide protection from the elements.

Part No.	Size	Cooling Capacity	Weight	External Dimensions			Internal Dimensions						Power
				H	W	D	Dairy/Fruit Compartment			Main Compartment			
							H	W	D	H	W	D	
10810602	63Qt	50°F to 0°F	70lbs	17.1"	19.3"	32.3"	5.7"	14.0"	6.1"	13.1"	14.0"	18.8"	Built-In 12/24V DC & 100-240V AC Power Integrated Battery Protection System

# CLASSIC FRIDGE FREEZER RANGE

**BRILLIANTLY RESEARCHED AND ENGINEERED, THE CLASSIC RANGE OF ARB FRIDGE FREEZERS ARE ACCLAIMED IN THE OFF-ROAD INDUSTRY FOR THEIR DURABILITY, METICULOUS DESIGN AND EASE OF USE.**

Engineered in Australia to handle the extreme conditions, ARB Fridge Freezers offer uncompromising performance with a temperature range from 0 ° to 50 ° fahrenheit, giving you the convenience of refrigerated or frozen food and drinks no matter where your journey takes you. The award winning design incorporates a drain plug, internal LED light and durable 90° fold back hinge that assists ease of use by

keeping the lid open while removing items from the fridge. An integrated battery protection system prevents excessive discharge of a vehicle's battery by allowing the user to select the minimum operating voltage.

The classic range of fridge freezers offers four convenient capacities to suit your individual needs.

## INTERNAL FEATURES

### Internal LED Light

Low power draw LED light with magnetic switch will turn off when the lid is closed.

### Drain Plug

Integrated into base of the fridge for effortless cleaning.

### Integrated Evaporator

Designed as an integral part of the interior cabinet, ensuring simplified cleaning and optimum use of internal storage space.

### Reversible Basket With Divider

Allows multiple storage options by separating fridge contents or alternatively allowing longer items to be positioned along the length of the cabinet.

### Secop Compressor

Highest quality, Secop compressor with smart electronic control system enables rapid cool down to target temperature.

### Capacity

Optimized internal cabinet includes separate compartment for fruit and dairy.

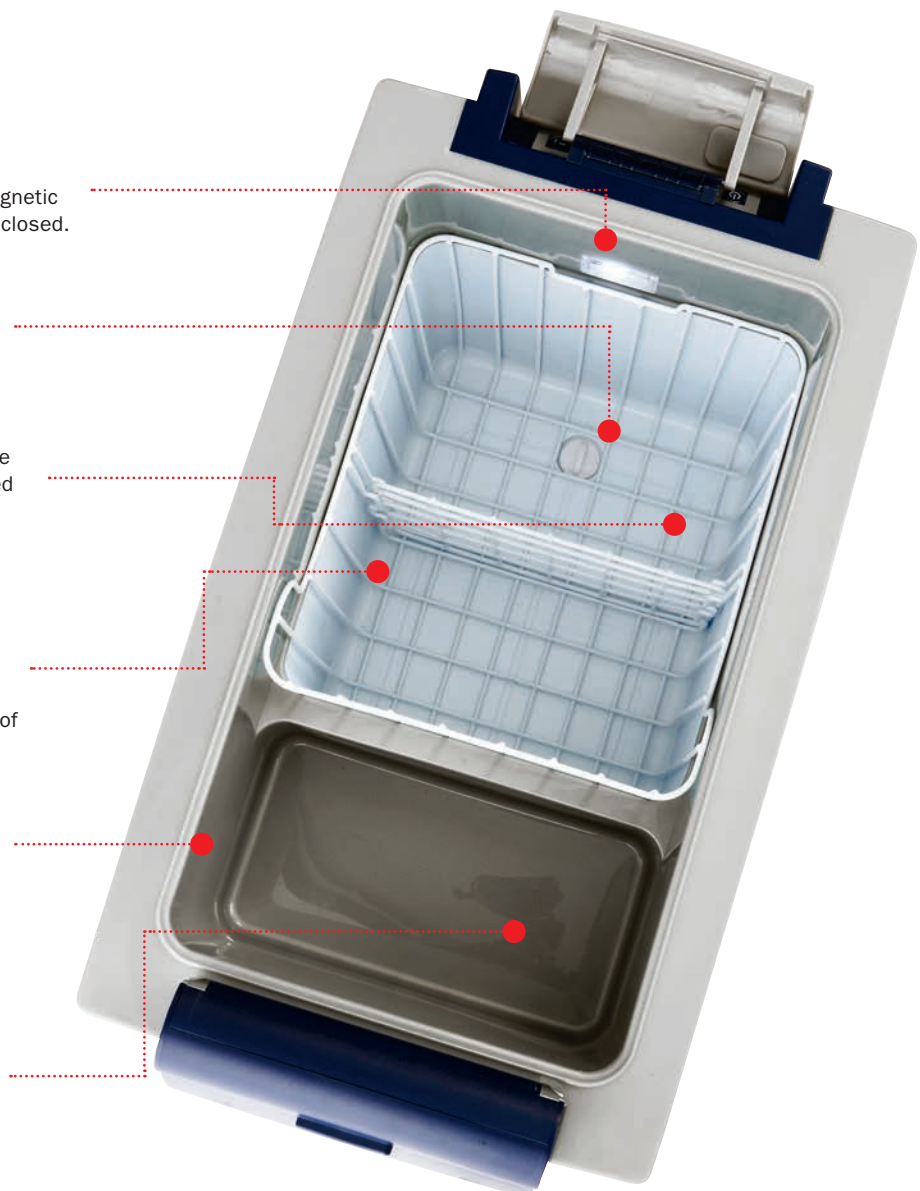

## EXTERNAL FEATURES

### Durable Detent Hinge

Stainless steel detent hinge ensures the lid can be easily removed and securely slid back into place.

### Lid & Integrated Seal

Tough, two-piece injection molded lid incorporates recessed seal, minimizing wear and damage.

### Front Latch

Simple to use, large over-center cam lock latch provides a positive seal between the lid and cabinet for optimum cooling efficiency.

### Control Panel

Easily accessible, recessed front control panel with maintenance-free digital temperature display (no dedicated battery required).



### Rear Clips

Rear clips secure 12/24V and 100-240V cables, preventing the plug from being accidentally disconnected.

### Rubber Feet

Integrated into fridge base for increased grip and stability.

### Recessed Handles

Powder coated, steel handles are engineered to double as tie down points.

### Durable Case

Powder coated, robust zinc steel case is designed to withstand extreme off-road conditions.

# THE COMPLETE FRIDGE FREEZER RANGE

AVAILABLE IN FIVE USER-FRIENDLY MODELS, THE ARB FRIDGE FREEZER SUITS A MYRIAD OF SITUATIONS, FROM FISHING AND WEEKEND CAMPING TO SERIOUS OFF-ROAD TRIPS.

A fridge freezer is one of the most important necessities when going on a trip. There's nothing better than reaching your destination, cracking a cold one, and enjoying your views without the worry of warm drinks and spoiled food.



## ▲ 37QT FRIDGE FREEZER

Part No.	Weight	External Dimen.			Internal Dimen.					
		H	W	D	Dairy/Fruit Com.			Main Com.		
		H	W	D	H	W	D	H	W	D
10800352	45lbs	16.9in	15in	27.8in	5in	11.2in	6in	12.6in	11.2in	13.3in

Built-in 12/24V DC and 100-240V AC power integrated battery protection system  
50°F to 0°F cooling capacity





### 50QT FRIDGE FREEZER

Part No.	Weight	External Dimen.			Internal Dimen.					
		H	W	D	Dairy/Fruit Com.			Main Com.		
		H	W	D	H	W	D	H	W	D
10800472	53lbs	20in	15in	27.8in	8.1in	11.2in	6in	15.5in	11.2in	13.3in

Built-in 12/24V DC and 100-240V AC power integrated battery protection system  
50°F to 0°F cooling capacity



### 63QT FRIDGE FREEZER

Part No.	Weight	External Dimen.			Internal Dimen.					
		H	W	D	Dairy/Fruit Com.			Main Com.		
		H	W	D	H	W	D	H	W	D
10800602	54lbs	16.9in	17.7in	33.3in	5in	14in	6in	12.6in	14in	18.8in

Built-in 12/24V DC and 100-240V AC power integrated battery protection system  
50°F to 0°F cooling capacity



### 82QT FRIDGE FREEZER

Part No.	Weight	External Dimen.			Internal Dimen.					
		H	W	D	Dairy/Fruit Com.			Main Com.		
		H	W	D	H	W	D	H	W	D
10800782	60lbs	20in	17.7in	33.3in	8.1in	14in	6in	15.8in	14in	18.8in

Built-in 12/24V DC and 100-240V AC power integrated battery protection system  
50°F to 0°F cooling capacity



### 63QT ELEMENTS WEATHERPROOF FRIDGE

Part No.	Weight	External Dimen.			Internal Dimen.					
		H	W	D	Dairy/Fruit Com.			Main Com.		
		H	W	D	H	W	D	H	W	D
10810602	70lbs	17.1in	19.3in	32.3in	5.7in	14in	6.1in	13.1in	14in	18.8in

Built-in 12/24V DC and 100-240V AC power integrated battery protection system  
50°F to 0°F cooling capacity

# FRIDGE FREEZER ACCESSORIES



## FRIDGE SLIDES

(37QT-50QT - 10900021)

(37QT-50QT EXTENDED - 10900029)

(63QT-82QT - 10900022)

(63QT ELEMENTS - 10900040)

Designed with a flat mounting base for easy, secure fitment to either side of the rear of your vehicle, the fridge slide range includes sealed roller bearings to prevent dust and grit ingress and ensure a consistent, clean slide. The clever lock-in/lock-out mechanism guarantees that the slide stays in the extended position, regardless of your vehicle's angle.

A simple solution for easy fridge access, the standard fridge slide is available in a number of sizes to accommodate the full range of ARB Fridge Freezers, including the new Elements Weatherproof Fridge Freezer. The full extension fridge slide allows 37Qt and 50Qt ARB Fridge Freezers to be pulled out to 100% extension. Designed with a maximum load of 264lbs, the fridge slide allows 176lbs on the main tray and 88lbs on the accessories tray located at the rear.



## WIRING LOOM

(10900027)

The ARB Wiring Loom is ideal for running power to a multitude of 12/24V DC items, including the ARB Fridge Freezers. With a variable length main loom to optimize the length of the cable, the wiring loom reduces voltage drop compared to many equivalent factory wiring looms. Eliminating low voltage cut-out caused by inadequate factory wiring, the loom will ensure your ARB Fridge Freezer delivers optimum performance no matter where your adventures take you.



## FRIDGE FREEZER REMOTE MONITOR

(10900026)

Utilizing wireless technology, the ARB Fridge Freezer Remote Monitor displays the operating conditions such as internal fridge temperature, supply voltage, and compressor status of your ARB Fridge Freezer on a conveniently located backlit display for the driver to monitor while in transit. The monitor is capable of displaying up to two fridges with the addition of a second transmitter and a range of selectable channel frequencies. Easy to install, the monitor is supplied with a quick release bracket and mounting system.



**ARB OFFERS A FULL LINE OF OPTIONAL ACCESSORIES  
FOR THE FRIDGE FREEZER RANGE.**



▲  
**TIE DOWN & PERMANENT MOUNTING SYSTEMS  
(CLASSIC FRIDGE TIE DOWN - 10900010)  
(ELEMENTS TIE DOWN - 10900038)  
(ELEMENTS SOLID MOUNT - 10900039)**

An ARB Tie Down Kit or Permanent Mounting System is the ideal solution to ensure your fridge is secured and protected in all conditions.

Complementing the ARB Classic Fridge Freezer's design, the black powder coated steel clamps and plastic coated ends, matched with webbing straps and quality spring loaded clips, provide a functional way to secure your fridge.

The tie down system for the ARB Elements Fridge Freezer attaches directly to the fridge via replacement bolts in the recessed handle and incorporates a bottle opener on each strap to enable instant access to cold beverages.

An optional permanent mounting kit for the Elements Fridge Freezer utilizes existing tamperproof bolts in the fridge to ensure it stays where it should.



▲  
**CLASSIC FRIDGE FREEZER TRANSIT BAGS  
(37QT - 10900012)  
(50QT - 10900013)  
(63QT - 10900014)  
(82QT - 10900015)**

The ARB Transit Bag is made from tough, durable canvas and is designed to protect the Classic Fridge Freezer range from dents and scratches while providing extra insulation in extreme temperatures. The bag incorporates a handy side storage pocket, a mesh panel to provide better air circulation to the compressor and is available in an attractive navy blue. Added features include openings for the fridge freezer's rubber feet, drain plug hole, and power cables.



**4X4 ACCESSORIES**

# **SAFARI SNORKELS**







# SAFARI SNORKELS

**PROTECTING YOUR ENGINE FROM DUST AND WATER INGESTION IS ESSENTIAL FOR KEEPING YOUR VEHICLE ON THE TRAIL. A SAFARI SNORKEL WILL ENSURE THAT CLEAN, DRY AIR IS ALWAYS AVAILABLE, REGARDLESS OF THE CONDITIONS.**



Created to protect vehicle engines from the hazards of dust and water ingestion commonly encountered in off-road driving, Safari Snorkels relocate your air intake point from the relatively low and vulnerable position under the hood to a higher and safer location, where a constant source of cool, clean, dry air is available.

Manufactured in Australia from premium quality polyethylene, Safari Snorkels are UV stable and incredibly resilient to withstand the harsh outback environment. All systems are individually designed to suit the most popular four-wheel drive vehicles and undergo thorough research and testing prior to being tooled for production.

Safari Snorkels are positively sealed to provide the ultimate in engine protection during river crossings and dusty desert driving conditions, while the quality fixtures and fittings, ensure superior appearance and durability.

## ARMAX™

Designed and tested on a custom built flow bench, the ARMAX range allows 25% to 70% more airflow than the vehicle manufacturers' standard air filter housing, while also providing a watertight raised air intake.

This ensures that if the vehicle owner wishes to increase their vehicle's engine performance (utilizing engine management, exhausts, upgraded intercoolers etc.), the Safari ARMAX™ Snorkel will provide the necessary airflow required.

## FEATURES

- Lifetime warranty
- Designed and flow tested by Safari engineers
- High-flow air ducting and body ensures air supply is in excess of engine requirements
- Each component is designed for maximum dust and water sealing
- Stainless steel plated hardware for corrosion resistance
- Unique separation system effectively disperses rain and unwanted moisture
- Developed to flow 30% more air over a standard Safari Snorkel
- Works in tandem with other performance modifications
- Created from industrial spec UV stabilized polyethylene