

**ARLEN NESS**



**50<sup>TH</sup> ANNIVERSARY**

*Quality Motorcycle Parts From California Craftsmen*



**A**

Air Cleaner Accessories ..... 93  
 Air Cleaners ..... 84-103

**B**

Brake Arms ..... 62-63  
 Brake Calipers ..... 46-48  
 Brake Pads ..... 49

**C**

Cam Covers ..... 114-117  
 Crash Bar Footpeg Mounts ..... 59

**D**

Derby Covers ..... 112-113  
 Dash Accessories ..... 112-111

**E**

Engine Covers ..... 114-117  
 Engine Links ..... 118  
 Engine Mount Brackets ..... 118  
 Exhausts ..... 106-107

**F**

Fairings ..... 19  
 Fairing Inserts ..... 111  
 Fenders, Front ..... 15-18  
 Fenders, Rear ..... 22  
 Floorboards ..... 53-54  
 Foot & Shift Pegs ..... 55-59  
 Fork Boots ..... 6-7  
 Fork Braces ..... 10  
 Fork Legs ..... 8-9  
 Forward Controls ..... 65  
 Fuel Doors ..... 113

**G**

Grips ..... 72-75

**H**

Hand Levers ..... 75  
 Handlebar Dampening Kit ..... 71  
 Handlebars ..... 70  
 Horn Covers ..... 123  
 Horn Kits ..... 122

**I**

Ignition Covers ..... 113

**K**

Kickstands ..... 11

**L**

Lifter Blocks ..... 116-119  
 License Frames ..... 133  
 Lowering Kits ..... 11

**M**

Mufflers ..... 104-105  
 Mirrors ..... 76-81

**O**

Oil Filters ..... 119  
 Oil Pressure Gauge Kits ..... 119

**P**

Point Covers ..... 114-115  
 Push Rod Covers ..... 114-118

**R**

Rear Fenders & Accessories ..... 20-23  
 Risers ..... 69  
 Rocker Box Covers ..... 114-117  
 Rotors ..... 38-45

**S**

Saddlebags ..... 20-23  
 Saddlebag Latch Covers ..... 124-125  
 Saddlebag Latch Levers ..... 125  
 Shift Arms ..... 60-61  
 Shift Rods ..... 64  
 Side Covers ..... 23

**T**

Transmission Covers ..... 114-117  
 Triple Trees ..... 5  
 Tour Pack ..... 23  
 Turn Signals ..... 132

**W**

Wheels ..... 26-35  
 Wheel Bearings ..... 49





# FRONT END & SUSPENSION

## SECTION CONTENT

- 5** Raked Triple Tree's
- 6** Fork Boots
- 8** Fork Legs
- 11** Fork Braces
- 11** Lowering Kits
- 11** Kickstands



**7&7 RAKED TRIPLE TREE FOR FLT MODELS**

- ▶ 7° forged aluminum triple trees that offer the best handling available when using 23" front wheels on your FLT Touring model
- ▶ Bolt-on installation, no frame modification necessary
- ▶ 7&7 triple trees offer 7" of trail when using 23" front wheels, 6-1/8" of trail when using 21" front wheels
- ▶ CNC machined from forged billet aluminum for optimum strength
- ▶ Each kit includes top and bottom tree, pressed in steel stem, lower fork bearing, hardware and travel limiters
- ▶ Batwing style fairings maintains factory position so headlight remains angled properly unlike other aftermarket kits which require additional brackets to correct headlight angle
- ▶ Available for 97-13 & 14-Up FLT Touring models
- ▶ Black anodize finish

**7&7 RAKED TREES**

**20-389** 7° Raked Tree for 14-Up FLT

**20-379** 7° Raked Tree for 97-13 FLT



7 & 7 Raked Triple Trees



20-389

**"KO" RAKED TRIPLE TREE FOR FL SOFTAIL® MODELS**

- ▶ 6° billet triple trees that properly rake your Softail® for the use of 21", 23" & 26" front wheels
- ▶ Bolt-on installation, no frame modification necessary
- ▶ Stock length fork tubes will work with 21" & 23" front wheels, 26" front wheel applications require 1" shorter fork tubes
- ▶ Each KO triple tree kit includes chrome plated top triple tree, black anodized bottom tree, fork stem and necessary hardware
- ▶ Available for 00-17 FLST/FLSTF Softail® models

**SOFTAIL® MODELS**

**20-372** 6° Raked Tree for 00-17 FLST/FLSTF



KO Raked Triple Trees



20-372



SMOOTH FORK BOOTS

### SMOOTH FORK BOOTS FOR FAT/WIDE TIRE FRONT ENDS

- ▶ Specially designed fork boots that feature notched inside surfaces to allow direct bolt-on fitment of 18"x 5.5" wide/fat front fenders & wheel kits on FLT Touring models
- ▶ CNC machined from billet aluminum
- ▶ Available in Smooth & 10-Gauge designs
- ▶ Universal design accepts all aftermarket fat/wide front fender kits
- ▶ Fork boots will work with factory and aftermarket fork legs
- ▶ 14-Up applications include a pair of factory spec fork seals
- ▶ Smooth styles are available in chrome finish & titanium or black anodize
- ▶ 10-Gauge available in black anodize with a contrast aluminum accent
- ▶ Sold in pairs



SMOOTH, CHROME



SMOOTH, BLACK



SMOOTH, TITANIUM



SMOOTH, Side View

### SMOOTH FORK BOOTS, FAT TIRE

- 20-040** Smooth All Black, 14-Up FLT/FLTR/FLHR
- 20-041** Smooth Chrome, 14-Up FLT/FLTR/FLHR
- 20-044** Smooth Titanium, 14-Up FLT/FLTR/FLHR
- 20-042** Smooth All Black, 99-13 FLT/FLHT/FLTR/FLHR, 06-13 FLHX
- 20-043** Smooth Chrome, 99-13 FLT/FLHT/FLTR/FLHR, 06-13 FLHX
- 20-045** Smooth Titanium, 99-13 FLT/FLHT/FLTR/FLHR, 06-13 FLHX

### 10-GAUGE FORK BOOTS, FAT TIRE

- 20-065** 10-Gauge All Black, 14-Up FLT/FLTR/FLHR
- 20-067** 10-Gauge All Black, FLT, FLHR 86-13 FLHT/06-13 FLHX Models



10-GAUGE, BLACK



FORK SEALS,  
(Included w/14-Up)

## FORK BOOTS

- ▶ Each fork boot is CNC machined from billet aluminum
- ▶ Available in Smooth, Retro, Deep Cut & 10-Gauge styles
- ▶ Replaces factory/OEM fork boots on FLT Touring & Softail® models
- ▶ Accepts factory or aftermarket lower fork legs
- ▶ +2" applications are 2" longer than factory boots and ensure no gap between fork boot & fork leg when using 26" wheels or extended fork tubes
- ▶ Sold in pairs

### 10-GAUGE BLACK

20-015 10-Gauge Black, 14-Up FLT/FLTR/FLHR

20-017 10-Gauge Black, FLT, FLHR 86-13 FLHT/06-13 FLHX Models

### 10-GAUGE CHROME

20-016 10-Gauge Chrome, 14-Up FLT/FLTR/FLHR

20-018 10-Gauge Chrome, FLT, FLHR, 86-13 FLHT/06-13 FLHX Models

### 10-GAUGE +2" BLACK

20-055 10-Gauge Black, 14-Up FLT/FLTR/FLHR

20-057 10-Gauge Black, FLT, FLHR 86-13 FLHT/06-13 FLHX Models

### 10-GAUGE +2" CHROME

20-056 10-Gauge Chrome, 14-Up FLT/FLTR/FLHR

20-058 10-Gauge Chrome, FLT, FLHR 86-13 FLHT/06-13 FLHX Models

### DEEP CUT BLACK

20-034 Deep Cut Black, 14-Up FLT/FLTR/FLHR

20-024 Deep Cut Black, 86-17 FLSTF, FLSTN (except 07)

20-014 Deep Cut Black, FLT, FLHR 86-13 FLHT/06-13 FLHX Models

### DEEP CUT CHROME

20-032 Deep Cut Chrome, 14-Up FLT/FLTR/FLHR

20-023 Deep Cut Chrome, 86-17 FLSTF, FLSTN (except 07)

20-012 Deep Cut Chrome, FLT, FLHR, 86-13 FLHT/06-13 FLHX Models

### DEEP CUT +2" BLACK

20-029 Deep Cut Black, 14-Up FLT/FLTR/FLHR

20-028 Deep Cut Black, 86-13 FLHT/06-13 FLHX Models

### DEEP CUT +2" CHROME

20-027 Deep Cut Chrome, 14-Up FLT/FLTR/FLHR

20-026 Deep Cut Chrome, 86-13 FLHT/06-13 FLHX Models

### RETRO BLACK

20-037 Retro Black, 14-Up FLT/FLTR/FLHR

20-004 Retro Black, 86-13 FLHT/06-13 FLHX Models

20-021 Retro Black, 86-17 FLSTF, FLSTN (except 07)

### RETRO CHROME

20-035 Retro Chrome, 14-Up FLT/FLTR/FLHR

20-002 Retro Chrome, 86-13 FLT/06-13 FLHX Models

20-020 Retro Chrome, 86-17 FLSTF, FLSTN (except 07)

### SMOOTH ALL BLACK, CHROME & TITANIUM

20-033 Smooth All Black, 14-Up FLT/FLTR/FLHR

20-036 Smooth Chrome, 14-Up FLT/FLTR/FLHR

20-038 Smooth Titanium, 14-Up FLT/FLTR/FLHR

20-007 Smooth All Black, FLT, FLHR 86-13 FLHT/06-13 FLHX Models

20-009 Smooth Chrome, FLT, FLHR 86-13 FLHT/06-13 FLHX Models

20-005 Smooth Titanium, FLT, FLHR 86-13 FLHT/06-13 FLHX Models



10-GAUGE



10-GAUGE, +2



DEEP CUT



DEEP CUT, +2"



RETRO



SMOOTH





06-521



06-520

### SMOOTH "HOT LEG" FORK LEGS

- ▶ CNC machined from billet aluminum
- ▶ Smooth design features universal clean styling
- ▶ Each fork leg features a tapered body with a hidden axle design
- ▶ Integrated brake caliper and fender mounts
- ▶ Single or dual disc applications available
- ▶ Fitment: FLT Touring & Softail® FLST/FXST models
- ▶ Choose from chrome finish, titanium or black anodize

### SMOOTH CHROME

40-501	14-Up FLT, Single Disc
40-503	14-Up FLT, Dual Disc
06-520	08-13 FLT, Single Disc
06-500	08-13 FLT, Dual Disc
06-522	00-07 FLT, Single Disc
06-503	00-07 FLT, Dual Disc
06-550	08-17 FLST, Single Disc
06-554	00-06 FLST, Single Disc

### SMOOTH ALL BLACK

40-511	14-Up FLT, Single Disc
40-513	14-Up FLT, Dual Disc
06-521	08-13 FLT, Single Disc
06-502	08-13 FLT, Dual Disc
06-523	00-07 FLT, Single Disc
06-504	00-07 FLT, Dual Disc
06-551	08-17 FLST, Single Disc
06-555	00-06 FLST, Single Disc

### SMOOTH TITANIUM

40-507	14-Up FLT, Dual Disc
06-501	08-13 FLT, Dual Disc
06-507	00-07 FLT, Dual Disc



SMOOTH

NEW

## DEEP CUT & 10-GAUGE HOT LEG FORK LEGS

- ▶ CNC machined from billet aluminum
- ▶ Each fork leg features a tapered body with a hidden axle design
- ▶ Integrated brake caliper and front fender mounts
- ▶ Single or dual disc applications available
- ▶ Fitment: FLT Touring & Softail® FLST/FXST models
- ▶ Choose from chrome or black anodize finish

### 10-GAUGE CHROME

40-516	14-Up FLT, Single Disc
40-517	14-Up FLT, Dual Disc
40-520	08-13 FLT, Single Disc
40-524	08-13 FLT, Dual Disc
40-522	00-07 FLT, Single Disc
40-526	00-07 FLT, Dual Disc

### 10-GAUGE BLACK

40-518	14-Up FLT, Single Disc
40-519	14-Up FLT, Dual Disc
40-521	08-13 FLT, Single Disc
40-525	08-13 FLT, Dual Disc
40-523	00-07 FLT, Single Disc
40-527	00-07 FLT, Dual Disc

### DEEP CUT CHROME

40-500	14-Up FLT, Single Disc
40-502	14-Up FLT, Dual Disc
06-524	08-13 FLT, Single Disc
06-510	08-13 FLT, Dual Disc
06-526	00-07 FLT, Single Disc
06-512	00-07 FLT, Dual Disc
06-552	08-17 FLST, Single Disc
06-556	00-06 FLST, Single Disc

### DEEP CUT BLACK

40-510	14-Up FLT, Single Disc
40-512	14-Up FLT, Dual Disc
06-525	08-13 FLT, Single Disc
06-511	08-13 FLT, Dual Disc
06-527	00-07 FLT, Single Disc
06-513	00-07 FLT, Dual Disc
06-553	08-17 FLST, Single Disc
06-557	00-06 FLST, Single Disc

### REPLACEMENT AXELS [FOR ALL STYLES]

06-505	14-Up FLT
06-516	00-07 FLT
06-517	08-13 FLT
06-508	00-06 FXST
06-509	07-17 FXST
06-518	00-06 FLST
06-519	08-17 FLST



40-512



10-GAUGE



DEEP CUT



20-351



49mm

### METHOD FORK BRACE

- ▶ CNC machined from forged aluminum
- ▶ Forged construction eliminates flex in your fork assembly
- ▶ Race inspired design installs without disassembly of front end for simple & fast installation
- ▶ Available in chrome, black, gold, blue or red anodize finish

#### 39mm

20-355	39mm, Chrome
20-354	39mm, All Black
20-368	39mm, Gold
20-367	39mm, Blue
20-369	39mm, Red

#### 49mm

20-351	49mm, Chrome
20-350	49mm, All Black
20-358	49mm, Gold
20-357	49mm, Blue
20-359	49mm, Red

#### NOTE:

**39mm fitment:** 00-Up XL, 91-05 FXD, FXR 88-94/99-00

Will not fit: XL 88SN/1200N/XR1200, FXDWG

**49mm fitment:** 06-17 FXD, 18-Up FXBB, FXLR

Will not fit: FXDWG.



Black



Chrome



Gold



Red



Blue

## COMPLETE LOWERING KITS

- ▶ Everything you need to lower the front and rear of the latest model Harley-Davidson®
- ▶ Specially designed fork dampers lower the front end without replacing factory springs
- ▶ Both kits for Softail® lower the front of FXST models by 2-1/2" and FLST models by 2" while the rear designs are adjustable to lower as much as desired
- ▶ Each kit includes 2 specially designed dampers, 2 adjustable rear shock adjusters, and a 1" shorter kickstand (fork oil not included)

**17-031** 07-13 FLT, except models w/ soft bags  
(excludes adjustable shock models)

**17-025** 00-06 Softail®, except Springer™ & Deuce™

**17-032** 07-17 Softail®, except Springer™, Deuce™, Rocker™ (except FXSB)

**NOTE:** Always check ground clearance and tire to fender clearance when installing these kits.



17-031 Complete Lowering Kit

## FRONT LOWERING KITS

- ▶ Ness design simplifies lowering the front end of your bike
- ▶ Specially designed fork dampers are shortened and drilled in a strategic position to obtain factory ride quality
- ▶ Utilizes factory fork springs
- ▶ Each kit includes 2 complete damper assemblies
- ▶ Will not fit Springer™, Deuce™, 06-Up FXD, or FXCW models

**28-002** 00-14 41 mm FXST & FLST (2" Lower) 1997-2013  
41 mm FLT except 02-06 FLT/FLHT (1-1/2" lower)

**NOTE:** Please check all clearances including front fender clearance with suspension travel bottomed out prior to riding your motorcycle.



28-002

## REAR LOWERING KITS

- ▶ Drop the rear end of your bike for a sleek, low profile
- ▶ Visible kits finished in black or polished to match factory swingarm
- ▶ Kits available in adjustable or standard drop
- ▶ Adjustable kits lower from 1" - 2"
- ▶ Standard drop kit lower bikes approximately 1"
- ▶ Supplied with mounting hardware or designed to use factory hardware

### ADJUSTABLE DROP

**17-100** 00-17 Softail® models

### STANDARD DROP

**17-110** 02-17 FLT models (exc. models w/ soft bags & CVO or FLHXS models and shock adjustable models or models with coil overshocks)

**NOTE:** With all lowering kits, check all clearances prior to riding your motorcycle.



17-100

17-110

## LOWERED KICKSTANDS

- ▶ A must when lowering your motorcycle
- ▶ Constructed of forged steel
- ▶ Kickstands are 1" shorter than stock
- ▶ Fitment for: 84-17 Softail®, 07-18 Dyna®

**11-016** 84-06 Softail® models

**11-021** 07-17 Softail® models

**11-023** 90-17 Dyna® models

**11-022** 07-Up FLT models



11-016

11-021



TOYOTA SONOMA





# FENDERS & BODYWORK

## SECTION CONTENT

- 15** Fat Tire Front Fenders
- 16** Front Fenders
- 19** Fairings
- 20** Stretched Saddlebags
- 22** Rear Fenders
- 23** Tour Packs
- 23** Side Covers





NEW

06-703 PRO SHORT FAT FRONT FENDER

**FAT FRONT FENDER KITS**

- ▶ Specially designed steel front fenders that feature a wide width and notched sides to properly wrap 18" x 5.5" fat front wheels on FLT Touring/Bagger models
- ▶ Rapper (Fat) and Pro short (Fat) styles are both made from a single piece of 14-gauge steel
- ▶ Made in the USA
- ▶ Pro Short (Fat) fenders feature a short overall length to give an aggressive performance look
- ▶ Rapper (Fat) fenders are a full length fender that follows the contour of the front wheel perfectly
- ▶ Bolt-on installation, no modification required
- ▶ Pair with Arlen Ness fat/wide application fork boots for the complete look
- ▶ Complete kits that include smooth fork boots are available
- ▶ Fitment: FLT Touring models w/180mm 18" x 5.5" front wheels

**PRO SHORT FAT FENDERS**

06-703	14-Up FLT Touring
06-705	99-13 FLT Touring

**RAPPER FAT FENDERS**

06-704	14-Up FLT Touring
06-706	99-13 FLT Touring

**COMPLETE FENDER KITS (INCLUDES FORK BOOTS)**

60-700	Pro Short (Fat) w/Black Smooth Fork Boots, 14-Up
60-702	Pro Short (Fat) w/Black Smooth Fork Boots, 96-13
60-701	Rapper (Fat) w/Black Smooth Fork Boots, 14-Up
60-703	Rapper (Fat) w/Black Smooth Fork Boots, 99-13



Pro Short Fat Fender



Rapper Fat Fender





06-733



Pro Short



06-769



39/49 Pro Short

## PRO SHORT FRONT FENDERS

- ▶ The Pro Short fender features a short length performance inspired design
- ▶ Made in the USA from a single piece of 14-gauge steel
- ▶ Direct bolt-on design includes CNC machined billet brackets finished in gloss black anodize
- ▶ Allows clearance for up to 14" oversized brake rotors
- ▶ Available in 19", 21" & 23" sizes
- ▶ 19" fenders measure 5.90" wide and accept all 130/60-19" tires
- ▶ 21" fenders measure 5.90" wide and accept all 120/70-21" tires
- ▶ 23" fenders measure 6.30" wide and accept all 130/60-23" tires
- ▶ Each Pro Short front fender kit includes fender, billet brackets and standard mounting hardware
- ▶ Fitment: 99-13/14-Up FLT Touring & 13-17/18-Up Softail® Models

## FLT TOURING

**06-730** 19" Pro Short 14-Up FLT Touring

**06-731** 21" Pro Short 99-13 FLT Touring

**06-732** 21" Pro Short 14-Up FLT Touring

**06-733** 23" Pro Short 99-13 FLT Touring

**06-734** 23" Pro Short 14-Up FLT Touring

## SOFTAIL®

**06-785** 21" Pro Short 18-Up Softail® Fatboy FLFB

**06-786** 23" Pro Short 18-Up Softail® Fatboy FLFB

**06-794** 21" Pro Short 18-Up Softail® Slim FLSSL/  
Deluxe FLDE/Heritage Classic FLHC

**06-796** 23" Pro Short 18-Up Softail® Slim FLSSL/  
Deluxe FLDE/Heritage Classic FLHC

**06-790** 21" Pro Short 13-17 Softail® Breakout  
FXSB & 18-Up Softail Breakout FXBR

**06-792** 23" Pro Short 13-17 Softail® Breakout  
FXSB & 18-Up Softail Breakout FXBR

## 39/49 PRO SHORT FRONT FENDER KITS

- ▶ The 39/49 Pro Short front fender features an innovative bolt-on design that allows 21" x 3.50" wheels to be installed on 39mm narrow & 49mm mid glide front ends
- ▶ Specially cut notched sides are laser cut to perfectly wrap the front end and tire with proper clearances
- ▶ Made in the USA from a single piece of 14-gauge steel
- ▶ Direct bolt-on design includes CNC machined billet brackets finished in gloss black anodize
- ▶ Allows clearance for up to 14" oversized brake rotors
- ▶ 21" fender measure 5.90" wide and accept all 120/70 - 21" tires
- ▶ Each Pro Short 39/49 fender kit includes fender, billet brackets and standing mounting hardware
- ▶ Fitment: 39mm Narrow Glide: 88-05 FXD/FXR & 88-Up XL  
49mm Mid Glide: 06-17 FXD & 18-Up FXBB/FXLR

**06-769** 21" 39/49 Pro Short  
39mm Narrow Glide  
88-05 FXD Dyna®/FXR  
88-Up XL

**06-766** 21" 39/49 Pro Short for  
49mm Mid Glide  
06-17 FXD Dyna®  
18-Up FXBB Street Bob & FXLR Lowrider

## REAL STEEL RAPPER FRONT FENDERS

- ▶ Stamped from one piece of 14-gauge steel
- ▶ Curvaceous full-length design wraps your tire to perfection
- ▶ Direct bolt-on black anodized billet bracket is included
- ▶ Fenders allow enough clearance for oversized 14" brake rotors
- ▶ 21" fenders measure 5.90" wide and accept all 120/70-21" tires
- ▶ 23" fenders measure 6.30" wide and accept all 130/60-23" tires
- ▶ All fenders made in the USA
- ▶ Fitment: 99-13/14-Up FLT Touring & 13-17/18-Up Softail® Models

**06-735** 21" Real Steel Rapper fits 99-13 Touring models

**06-736** 21" Real Steel Rapper fits 14-Up Touring models

**06-737** 23" Real Steel Rapper fits 99-13 Touring models

**06-738** 23" Real Steel Rapper fits 14-Up Touring models

**06-787** 21" Real Steel Rapper fits 2018-Up Fatboy

**06-788** 23" Real Steel Rapper fits 2018-Up Fatboy

**06-791** 21" Real Steel Rapper fits FLSL Slim, 2018 FLDE Deluxe and Heritage Classic

**06-793** 23" Real Steel Rapper fits Slim, FLDE Deluxe and FLHC Heritage Classic



06-737



Rapper

## PROFILE FRONT FENDERS

- ▶ Profile front fenders features a medium length with smooth flowing lines that perfectly follows the contour of the front wheel
- ▶ Made in the USA from a single piece of 14-gauge steel
- ▶ Direct bolt-on design includes CNC machined billet brackets finished in gloss black anodize
- ▶ Allows clearance for up to 14" oversized brake rotors
- ▶ 21" fenders measure 5.90" wide and accept all 120/70-21" tires
- ▶ 23" fenders measure 6.30" wide and accept all 130/60-23" tires
- ▶ Each Profile fender kit includes fender, billet brackets and standard mounting hardware
- ▶ Fitment: 06-17 FXD, 18-Up FXBB/FXLR & 13-Up FXSB/FXBR

**06-768** 21" Profile 06-17 FXD Dyna® & 18-Up FXBB Street Bob/FXBR Breakout

**06-758** 21" Profile Fender fits 13-17 FXSB & 18-Up FXBR Breakout

**06-759** 23" Profile Fender fits 13-17 FXSB; 18-up Breakout



06-758



Profile



06-723



Carbon Composite



Standard Composite



21" Fender Brackets

## WRAPPER FRONT FENDERS

- ▶ Our Wrapper front fenders perfectly follow the contour of your 21", 23", or 26" front wheel
- ▶ Fenders are available in carbon fiber composite and standard composite materials. Both are handmade in the USA
- ▶ Carbon composite fenders are constructed from a blend of composite materials with a layer of carbon fiber for fenders as strong as steel with less than half the weight
- ▶ Standard composite fenders are constructed from high quality fiberglass materials that are cured in a computer controlled oven over a wide heat range for durability and strength
- ▶ Both composite style fenders are an average of 8 lbs lighter than most similar steel fenders, saving weight and improving gas mileage
- ▶ Available for FLT Touring & FLST/FXST

### 87-13 FLT CARBON COMPOSITE FENDER

06-757	21" Wrapper, carbon composite, FLT
06-746	23" Wrapper, carbon composite, FLT
06-749	26" Wrapper, carbon composite, FLT

### 14-Up FLT CARBON COMPOSITE FENDER

06-723	21" Wrapper, carbon composite, FLT
06-724	23" Wrapper, carbon composite, FLT
06-726	26" Wrapper, carbon composite, FLT

### 87-13 FLT STANDARD COMPOSITE FENDER

06-752	21" Wrapper fender, FLT
06-745	23" Wrapper fender, FLT
06-747	26" Wrapper fender, FLT

### 14-Up FLT STANDARD COMPOSITE FENDER

06-721	21" Wrapper fender, FLT
06-725	23" Wrapper fender, FLT
06-727	26" Wrapper fender, FLT

### 86-17 SOFTAIL® CARBON COMPOSITE FENDER

06-756	21" Wrapper, carbon composite, FLST, 86-17 (exc.07)
06-744	23" Wrapper, carbon composite, FLST, 86-17 (exc.07)
06-748	26" Wrapper, carbon composite, FLST, 96-17 (exc.07)

### 21" FENDER BRACKETS FOR 14-Up FLT TOURING

- ▶ Properly re-locates the front fender on 14-Up FLT Touring models when using a 21" front wheel.
- ▶ Designed to work with a 21" x 3.5" wheels on 14-Up FLT models
- ▶ Steel construction
- ▶ Available in chrome or black powder coat finish
- ▶ Sold in pairs

60-122	21" Fender bracket kit for 14-Up FLT for stock legs, black
60-123	21" Fender bracket kit for 14-Up FLT Ness "Hot Leg" fork legs, black
60-124	21" Fender bracket kit for 14-Up FLT for stock legs, chrome
60-125	21" Fender bracket kit for 14-Up FLT for Ness fork legs, chrome

**DIRECT BOLT-ON FAIRINGS FOR SPORTSTER® AND DYNA® MODELS**

- ▶ The Original Arlen Ness fairing in a direct bolt-on kit for your Sportster® or Dyna®, no custom fabrication needed
- ▶ Fairing adds style and protection from the elements
- ▶ The fairing body is constructed from heavy ABS plastic, which is the same material used for OEM saddlebags. Windshield is smoked plexiglass
- ▶ Choose from paint-able finish or gloss black coated ABS finish
- ▶ Available for 04-Up Sportster® with 39mm forks and top mount headlight, 06-Up Dyna® models (Except FXDF & FXDWG), and 16-Up Sportster® 48 models
- ▶ Made in USA

**DIRECT BOLT-ON FAIRINGS FOR SPORTSTER®**

- 06-037** 04-Up Sportster® (excludes 16-Up 48 XL), gloss black finish

---

- 06-038** 16-Up 48 XL, Gloss Black finish

---

- 06-039** 04-Up Sportster® (excludes 16-18 48 XL), paintable finish

---

- 06-047** Replacement smoked windshield

**DIRECT BOLT-ON FAIRINGS FOR DYNA®**

- 06-033\*** 06-17 Dyna® FXD gloss black finish

---

- 06-035\*** 06-17 Dyna® FXD paintable finish

---

- 06-047** Replacement smoked windshield

\*NOTE: FXD models with bottom mount headlight. Does NOT fit FXDF/ FXDWG/FXDL Dyna® models.



06-033



06-037

**ORIGINAL FAIRING KITS**

- ▶ The fairing that started it all
- ▶ Universal design can be used on various applications
- ▶ Constructed of heavy ABS plastic while the windshield is made from smoked plexiglass
- ▶ Each fairing kit includes: 1 fairing body, 1 smoked windshield, universal mounting brackets & windshield mounting screws

**ORIGINAL FAIRING KITS**

- 06-041** Ness plain fairing kit

---

- 06-043** Ness louvered fairing kit

---

- 06-087\*** Ness wide-glide & custom mid-glide fairing kit

\*NOTE: Does not include direct bolt-on brackets, fabrication may be required

**REPLACEMENT ACCESSORIES**

- 06-047** Replacement smoked windshield

---

- 06-048** Custom headlight bracket

---

- 06-049** Replacement fastener kit

**BOB DRON FAIRING KIT FOR ROAD KING®**

- ▶ Classic fairing provides protection from the elements
- ▶ Accepts factory spot lights
- ▶ Fairing body constructed in heavy ABS, windshield is smoked plexiglass
- ▶ Fairing kits include: 1 fairing body, 1 smoked windshield, stainless steel mounting brackets and windshield mounting hardware
- ▶ Fitment for 97-Up FLHR models

- 06-950** Bob Dron fairing kit

---

- 06-951** Replacement smoked windshield

NOTE: Please check fit and finish prior to painting. Arlen Ness will not be responsible for any damage sustained to paint jobs.



Louvered

Plain



Bob Dron Fairing Kit



DOWN-N-OUT STRETCHED SADDLEBAGS



### DOWN-N-OUT STRETCHED SADDLEBAGS, ABS

- ▶ Injected molded ABS versions of our Down-N-Out saddlebags that are 6" longer and 2" lower than our original Big Bags for the most extreme stretch we offer
- ▶ Features a tapered bottom that provides a clean and original look while offering an additional 2" of ground clearance
- ▶ Each bag is constructed from injected molded ABS plastic that provides superior strength and durability for the perfect fit every time from a name you can trust (Same materials used in factory saddlebags)
- ▶ Accepts factory sized lids and hardware
- ▶ Available for 93 - 13 & 14-Up FLT touring models
- ▶ Offered with dual exhaust outlets
- ▶ Sold individually

#### 93-13 FLT

- 60-160 Down-N-Out, Left Hand
- 60-161 Down-N-Out, Right Hand

#### 14-Up FLT

- 60-165 Down-N-Out, Left Hand
- 60-166 Down-N-Out, Right Hand

### DOWN-N-OUT REAR FENDER EXTENSIONS, ABS

- ▶ Down-N-Out rear fender extensions bolt straight to your factory rear fender to add length and match our Down-N-Out stretched saddlebags
- ▶ Constructed from injected molded ABS plastic
- ▶ Provides the stretched fender look and fills the gap between rear fender and saddlebags
- ▶ Utilizes factory rear fender and tri-bar light/license assembly for the stretched look at less than half the cost
- ▶ Available for 09-Up FLT touring models equipped with tri-bar rear license/light assembly

- 60-159 Down-N-Out Rear Fender Extension

### DOWN-N-OUT EXHAUST EXTENSION KIT

- ▶ Everything you need to extend your factory or aftermarket exhaust to the proper length for use with Down-N-Out Saddlebags and rear fenders/fender extensions
- ▶ Each kit includes head pipe extensions, chrome heat shield extensions, exhaust clamps and muffler hanger brackets
- ▶ Available for 08-16 & 17-Up FLT

- 60-120 Down-N-Out Exhaust Extension, 08-16 FLT

- 60-126 Down-N-Out Exhaust Extension, 17-Up FLT



Down-N-Out, ABS



Down-N-Out, Rear Fender Extension



Down-N-Out, Exhaust Extension Kit



ANGLED STRETCHED SADDLEBAG

**ANGLED SADDLEBAGS, ABS**

- ▶ Arlen's angled cut design gives you the ultimate look while providing maximum cornering clearance
- ▶ Each saddlebag is stretched 5" longer than stock to cover your muffler from front to back and provide a stretched look
- ▶ These injected molded ABS saddlebags provide consistent quality, superior strength and rigidity. Perfect fit every time from a name you can trust
- ▶ Saddlebags have cutouts for dual exhaust applications. For custom applications with single exhaust or no exhaust exits, block off plugs are available separately
- ▶ Please order a right and left for each motorcycle
- ▶ Sold individually

**ANGLED SADDLEBAGS**

- 60-150 97-13 FLT, Left Side
- 60-151 97-13 FLT, Right Side
- 60-155 14-Up FLT, Left Side
- 60-156 14-Up FLT, Right Side

**BACK-OFF PLUGS**

- 60-152 97-13 FLT, Left Side
- 60-153 97-13 FLT, Right Side
- 60-168 14-Up FLT, Left Side
- 60-169 14-Up FLT, Right Side

**ANGLED FENDER EXTENSION, ABS**

- ▶ Our Angled Fender Extension bolts straight to your stock rear fender while utilizing the factory tri-bar light
- ▶ Provides the stretched fender look. Fills the gap between rear fender and saddlebags.
- ▶ Matches perfectly with our Stretched Angled Saddlebags
- ▶ Constructed from heavy ABS plastic and ready to paint
- ▶ Available for 09-Up FLT models with rear fenders equipped with tri-bar lights

- 60-154 Angled Fender Extension 14-Up FLT
- 60-158 Angled Fender Extension 09-13 FLT

**NOTE:** please check fit and finish of bags, fender extension and block-off plugs prior to painting. Arlen Ness will not be responsible for any damage sustained to paint jobs.



14-Up



97-13



60-152/60-153  
Back-Off Plugs



60-154 Angled Fender Extension



06-978



DNO, Dual Exhaust

DNO, Single Exhaust



60-110



06-474 NO Hole Exhaust

06-483 Single Exhaust

06-487 Dual w/o Pocket

## DOWN-N-OUT STRETCHED SADDLEBAGS, COMPOSITE

- ▶ Down-N-Out extreme stretched saddlebags made from aircraft quality composite materials, made in the USA
- ▶ Each saddlebag is stretched 6" longer and 2" lower than our original stretched saddlebags and feature a tapered bottom for more ground clearance while cornering
- ▶ Each bag is constructed from premium composite materials/fibers, hand placed fibers are strategically located to provide the highest structural integrity possible while maintaining a low overall weight
- ▶ Cured in computer-controlled ovens over a wide heat range for maximum durability
- ▶ Jig quality control process ensures proper fitment
- ▶ Saddlebags are primed in a super high quality polyester sanding primer
- ▶ Accepts factory saddlebag lids (or custom lids made to factory fitment spec)
- ▶ Choose from dual, single or no exhaust applications
- ▶ Available for 93-13 & 14-Up Harley-Davidson FLT Touring Bagger models
- ▶ Sold in pairs

### 93-13 FLT

**06-978** Dual exhaust stretched bag kit

**06-979** Single exhaust stretched bag kit

**06-982** NO exhaust stretched bag kit

### 14-Up FLT

**60-111** Dual exhaust stretched bag kit

**60-113** Single exhaust stretched bag kit

**60-115** NO exhaust stretched bag kit

**NOTE:** Check fit & finish prior to paint

## DOWN-N-OUT STRETCHED REAR FENDERS, COMPOSITE

- ▶ Down-N-Out full replacement stretched fender kits are designed to work and flow with our Down-N-Out stretched saddlebags
- ▶ Each fender is constructed from premium composite materials/fibers, hand placed fibers are strategically located to provide the highest structural integrity possible while maintaining a low overall weight. Made in the USA
- ▶ Oven cured over a wide heat range to ensure quality and durability, each fender is put through a 14-point quality control process
- ▶ Includes a Ness LED license/taillight assembly with integrated turn signals for an all in one rear lighting solution that mounts in the recessed area of the fender for a clean look
- ▶ Primed and finished in a super high quality polyester sanding primer that is ready for paint
- ▶ Choose from Dual, Single and No Exhaust outlet configurations
- ▶ Available for 97-Up FLT Touring Bagger models
- ▶ Each fender kit includes: rear fender, LED license assembly, hidden steel fender support brackets, flexible hidden antenna, exhaust extensions, chrome heat shield extensions and necessary hardware (No license pocket applications do not include LED license assembly)

### FENDERS

**06-480** 97-08 FLT, dual exhaust

**06-486** 97-08 FLT, dual w/o license plate pocket/assembly

**06-481** 97-08 FLT, single exhaust

**06-474** 97-08 FLT, NO exhaust

**06-482** 09-13 FLT, dual exhaust

**06-487** 09-13 FLT, dual w/o license plate pocket/assembly

**06-483** 09-13 FLT, single exhaust

**06-476** 09-13 FLT, NO exhaust

**60-110** 14-Up FLT, dual exhaust

**60-112** 14-Up FLT, single exhaust

**60-114** 14-Up FLT, NO exhaust

**NOTE:** please check fit and finish of bags prior to painting bags. Arlen Ness will not be responsible for any damage sustained to paint jobs

## TOUR PACK

- ▶ Injection-molded ABS tour pack constructed from OEM-grade materials for superior strength and rigidity
- ▶ Chopped profile features an angled design to match our Angled and Down-N-Out saddlebags
- ▶ Precision manufacturing results in a near perfect finish
- ▶ Each tour pack includes tour pack top, tour pack bottom, inner mounting plate and gasket/seal

**60-170** Arlen Ness Tour Pack



## SIDE COVERS FOR FXR™

- ▶ Available for all FXR™ models 82-94 & 99-00
- ▶ Constructed from high-impact ABS plastic
- ▶ Side covers conceal brake and electrical components while providing an appealing look
- ▶ Ready for prep and paint

**03-600** FXR™ side cover kit, pair



FXR Side Covers







# WHEELS & BRAKES

## SECTION CONTENT

- 26** Wheels
- 41** Wheel Components
- 42** Brake Rotors
- 43** Big Brake Kits
- 46** Brake Calipers
- 49** Wheel Bearings



FLARE 5

### FLARE 5 WHEELS

The FLARE 5 represents the next level in motorcycle wheel design. Sculpted CNC features extend from the axle all the way to the outer edge of the rim lip. Its multi-piece design features a radial forged rim, forged hub covers, hidden cartridge hub and spoke mounted 14" rotors for a full 3D wheel with enhanced braking performance. FLARE 5 is the first design in the Ness Multi-piece Premium wheel series.

- ▶ Precision machined from radial forged 6061-T6 aluminum for maximum road durability
- ▶ Structurally tested to meet or exceed DOT, JAS and TUV international load ratings
- ▶ Hidden hub design features a single piece cartridge type hub that includes both pre-set bearings
- ▶ Forged hub covers are specially designed to bring full 3D styling from the bearing in the hub to the outer edge of the rim lip
- ▶ Matching performance brake rotors available. Choose from 14" & 11.8" front spoke mounted rotors & 11.5"/11.8" rear hub mounted rotors





DRIFT

### DRIFT WHEELS

Utilizing our proprietary single piece hub and hub cover combination the DRIFT wheel brings directional CNC design from very center of the rim to the very edge of the lip to set your bike in motion even when it's on the kickstand. The DRIFT is the second design in the Ness Multi-piece Premium wheel series.

- ▶ Precision machined from radial forged 6061-T6 aluminum for maximum road durability
- ▶ Structurally tested to meet or exceed DOT, JAS and TUV international load ratings
- ▶ Hidden hub design features a single piece cartridge type hub that includes both pre-set bearings
- ▶ Forged hub covers are specially designed to bring full 3D styling from the bearing in the hub to the outer edge of the rim lip
- ▶ Matching performance brake rotors available. Choose from 14" & 11.8" front spoke mounted rotors & 11.5"/11.8" rear hub mounted rotors



**FLARE 5 & DRIFT WHEELS**

<b>FRONT 18" X 3.5" [FOR 14" ROTORS]</b>	<b>FLARE 5 CHROME</b>	<b>FLARE 5 BLACK</b>	<b>DRIFT CHROME</b>	<b>DRIFT BLACK</b>
08-Up FLTR/FLHT/FLHR (NON-ABS)	10002-107-6001	10001-107-6001	10202-107-6001	10201-107-6001
08-Up FLTR/FLHT/FLHR, S/D (NON-ABS)	10002-107-6003	10001-107-6003	10202-107-6003	10201-107-6003
08-Up FLTR/FLHT/FLHR (ABS)	10002-107-6005	10001-107-6005	10202-107-6005	10201-107-6005
08-Up FLTR/FLHT/FLHR, S/D (ABS)	10002-107-6007	10001-107-6007	10202-107-6007	10201-107-6007
00-07 FLTR/FLHT/FLHR	10002-107-6021	10001-107-6021	10202-107-6021	10201-107-6021
00-07 FLTR/FLHT/FLHR, S/D	10002-107-6023	10001-107-6023	10202-107-6023	10201-107-6023
11-17 FLSTN/C (ABS) (Exc. 18 FLSTF)	10002-107-6061	10001-107-6061	10202-107-6061	10201-107-6061
08-17 FLSTF/C/N (Exc. 18 FLSTF)	10002-107-6063	10001-107-6063	10202-107-6063	10201-107-6063

<b>FRONT 18" X 3.5" [FOR 11.8" ROTORS]</b>	<b>FLARE 5 CHROME</b>	<b>FLARE 5 BLACK</b>	<b>DRIFT CHROME</b>	<b>DRIFT BLACK</b>
08-Up FLTR/FLHT/FLHR (NON-ABS)	10002-107-6101	10001-107-6101	10202-107-6101	10201-107-6101
08-Up FLTR/FLHT/FLHR, S/D (NON-ABS)	10002-107-6103	10001-107-6103	10202-107-6103	10201-107-6103
08-Up FLTR/FLHT/FLHR (ABS)	10002-107-6105	10001-107-6105	10202-107-6105	10201-107-6105
08-Up FLTR/FLHT/FLHR, S/D (ABS)	10002-107-6107	10001-107-6107	10202-107-6107	10201-107-6107

<b>FRONT 21" X 3.5" [FOR 14" ROTORS]</b>	<b>FLARE 5 CHROME</b>	<b>FLARE 5 BLACK</b>	<b>DRIFT CHROME</b>	<b>DRIFT BLACK</b>
08-Up FLTR/FLHT/FLHR (NON-ABS)	10002-104-6001	10001-104-6001	10202-104-6001	10201-104-6001
08-Up FLTR/FLHT/FLHR, S/D (NON-ABS)	10002-104-6003	10001-104-6003	10202-104-6003	10201-104-6003
08-Up FLTR/FLHT/FLHR (ABS)	10002-104-6009	10001-104-6009	10202-104-6009	10201-104-6009
08-Up FLTR/FLHT/FLHR, S/D (ABS)	10002-104-6011	10001-104-6011	10202-104-6011	10201-104-6011
00-07 FLTR/FLHT/FLHR	10002-104-6021	10001-104-6021	10202-104-6021	10201-104-6021
00-07 FLTR/FLHT/FLHR, S/D	10002-104-6023	10001-104-6023	10202-104-6023	10201-104-6023
07-17 FXST	10002-104-6057	10001-104-6057	10202-104-6057	10201-104-6057
11-17 FXST, ABS	10002-104-6059	10001-104-6059	10202-104-6059	10201-104-6059
11-17 FLSTN/C (ABS)	10002-104-6061	10001-104-6061	10202-104-6061	10201-104-6061
08-17 FLSTF/C/N (Exc. 18 FLSTF)	10002-104-6063	10001-104-6063	10202-104-6063	10201-104-6063
00-06 FXST/00-05 FXDWG	10002-104-6067	10001-104-6067	10202-104-6067	10201-104-6067

<b>FRONT 21" X 3.5" [FOR 11.8" ROTORS]</b>	<b>FLARE 5 CHROME</b>	<b>FLARE 5 BLACK</b>	<b>DRIFT CHROME</b>	<b>DRIFT BLACK</b>
08-Up FLTR/FLHT/FLHR (NON-ABS)	10002-104-6101	10001-104-6101	10202-104-6101	10201-104-6101
08-Up FLTR/FLHT/FLHR, S/D (NON-ABS)	10002-104-6103	10001-104-6103	10202-104-6103	10201-104-6103
08-Up FLTR/FLHT/FLHR (ABS)	10002-104-6109	10001-104-6109	10202-104-6109	10201-104-6109
08-Up FLTR/FLHT/FLHR, S/D (ABS)	10002-104-6111	10001-104-6111	10202-104-6111	10201-104-6111

<b>FRONT 23" X 3.5" [FOR 14" ROTORS]</b>	<b>FLARE 5 CHROME</b>	<b>FLARE 5 BLACK</b>	<b>DRIFT CHROME</b>	<b>DRIFT BLACK</b>
08-Up FLTR/FLHT/FLHR (NON-ABS)	10002-105-6001	10001-105-6001	10202-105-6001	10201-105-6001
08-Up FLTR/FLHT/FLHR, S/D (NON-ABS)	10002-105-6003	10001-105-6003	10202-105-6003	10201-105-6003
08-Up FLTR/FLHT/FLHR (ABS)	10002-105-6013	10001-105-6013	10202-105-6013	10201-105-6013
08-Up FLTR/FLHT/FLHR, S/D (ABS)	10002-105-6015	10001-105-6015	10202-105-6015	10201-105-6015
00-07 FLTR/FLHT/FLHR	10002-105-6021	10001-105-6021	10202-105-6021	10201-105-6021
00-07 FLTR/FLHT/FLHR, S/D	10002-105-6023	10001-105-6023	10202-105-6023	10201-105-6023
07-17 FXST	10002-105-6057	10001-105-6057	10202-105-6057	10201-105-6057
11-17 FLSTN/C (ABS)	10002-105-6061	10001-105-6061	10202-105-6061	10201-105-6061
08-17 FLSTF/C/N (Exc. 18 FLSTF)	10002-105-6063	10001-105-6063	10202-105-6063	10201-105-6063
00-06 FXST/00-05 FXDWG	10002-105-6067	10001-105-6067	10202-105-6067	10201-105-6067

<b>FRONT 23" X 3.5" [FOR 11.8" ROTORS]</b>	<b>FLARE 5 CHROME</b>	<b>FLARE 5 BLACK</b>	<b>DRIFT CHROME</b>	<b>DRIFT BLACK</b>
08-Up FLTR/FLHT/FLHR (NON-ABS)	10002-105-6101	10001-105-6101	10202-105-6101	10201-105-6101
08-Up FLTR/FLHT/FLHR, S/D (NON-ABS)	10002-105-6103	10001-105-6103	10202-105-6103	10201-105-6103
08-Up FLTR/FLHT/FLHR (ABS)	10002-105-6113	10001-105-6113	10202-105-6113	10201-105-6113
08-Up FLTR/FLHT/FLHR, S/D (ABS)	10002-105-6115	10001-105-6115	10202-105-6115	10201-105-6115

<b>FRONT 26" X 3.5" [FOR 14" ROTORS]</b>	<b>FLARE 5 CHROME</b>	<b>FLARE 5 BLACK</b>	<b>DRIFT CHROME</b>	<b>DRIFT BLACK</b>
08-Up FLTR/FLHT/FLHR (NON-ABS)	10002-106-6001	10001-106-6001	10202-106-6001	10201-106-6001
08-Up FLTR/FLHT/FLHR, S/D, [NON-ABS]	10002-106-6003	10001-106-6003	10202-106-6003	10201-106-6003
08-Up FLTR/FLHT/FLHR (ABS)	10002-106-6017	10001-106-6017	10202-106-6017	10201-106-6017
08-Up FLTR/FLHT/FLHR S/D (ABS)	10002-106-6019	10001-106-6019	10202-106-6019	10201-106-6019
00-07 FLTR/FLHT/FLHR	10002-106-6021	10001-106-6021	10202-106-6021	10201-106-6021
00-07 FLTR/FLHT/FLHR, S/D	10002-106-6023	10001-106-6023	10202-106-6023	10201-106-6023

<b>FRONT 26" X 3.5" [FOR 11.8" ROTORS]</b>	<b>FLARE 5 CHROME</b>	<b>FLARE 5 BLACK</b>	<b>DRIFT CHROME</b>	<b>DRIFT BLACK</b>
08-Up FLTR/FLHT/FLHR (NON-ABS)	10002-106-6101	10001-106-6101	10202-106-6101	10201-106-6101
08-Up FLTR/FLHT/FLHR, S/D, [NON-ABS]	10002-106-6103	10001-106-6103	10202-106-6103	10201-106-6103
08-Up FLTR/FLHT/FLHR (ABS)	10002-106-6117	10001-106-6117	10202-106-6117	10201-106-6117
08-Up FLTR/FLHT/FLHR S/D (ABS)	10002-106-6119	10001-106-6119	10202-106-6119	10201-106-6119

<b>REAR 17" X 6.25"</b>	<b>FLARE 5 CHROME</b>	<b>FLARE 5 BLACK</b>	<b>DRIFT CHROME</b>	<b>DRIFT BLACK</b>
09-Up FLT (NON-ABS)	10002-101-6500	10001-101-6500	10202-101-6500	N/A
09-Up FLT (ABS)	10002-101-6501	10001-101-6501	10202-101-6501	N/A
06 FXST/2006 FLSTFSE	10002-101-6506	10001-101-6506	10202-101-6506	N/A
07 FXST/FLSTF	10002-101-6507	10001-101-6507	10202-101-6507	N/A
08-17 FXST/08-10 FLSTF/11-17 FLSTF/FB/SB (Exc.18 FLSTF)	10002-101-6509	10001-101-6509	10202-101-6509	N/A
11-13 FXST/FLSTF/FB/SB (ABS)	10002-101-6510	10001-101-6510	10202-101-6510	N/A

<b>REAR 18" X 3.5"</b>	<b>FLARE 5 CHROME</b>	<b>FLARE 5 BLACK</b>	<b>DRIFT CHROME</b>	<b>DRIFT BLACK</b>
08 FLTR/FLHT/FLHR (NON-ABS)	10002-102-6502	10001-102-6502	10202-102-6502	10201-102-6502
08 FLTR/FLHT/FLHR (ABS)	10002-102-6503	10001-102-6503	10202-102-6503	10201-102-6503
02-07 FLT	10002-102-6504	10001-102-6504	10202-102-6504	10201-102-6504
00-01 FLT	10002-102-6505	10001-102-6505	10202-102-6505	10201-102-6505
08-17 FXST/FLST/FXS/FLS	10002-102-6509	10001-102-6509	10202-102-6509	10201-102-6509
11-17 FXST/FLSTN/C (ABS)	10002-102-6510	10001-102-6510	10202-102-6510	10201-102-6510
00-07 FLST	10002-102-6512	10001-102-6512	10202-102-6512	10201-102-6512

<b>REAR 18" X 5.5"</b>	<b>FLARE 5 CHROME</b>	<b>FLARE 5 BLACK</b>	<b>DRIFT CHROME</b>	<b>DRIFT BLACK</b>
09-Up FLT 180mm (NON-ABS)	10002-103-6500	10001-103-6500	10202-103-6500	10201-103-6500
09-Up FLT 180mm (ABS)	10002-103-6501	10001-103-6501	10202-103-6501	10201-103-6501
08 FLT 180mm (NON-ABS)	10002-103-6502	10001-103-6502	10202-103-6502	10201-103-6502
08 FLT 180mm (ABS)	10002-103-6503	10001-103-6503	10202-103-6503	10201-103-6503
08-17 FXST	10002-103-6509	10001-103-6509	10202-103-6509	10201-103-6509
11-17 FXST/FLSTF/FB/SB (ABS) (Exc.18 FLSTF)	10002-103-6510	10001-103-6510	10202-103-6510	10201-103-6510
18-Up Fatbob (NON_ABS)	10002-103-6631	10001-103-6631	10202-103-6631	10201-103-6631
18-Up Fatbob (ABS)	10002-103-6630	10001-103-6630	10202-103-6630	10201-103-6630



7-VALVE

### 7-VALVE

Clean 7 spoke design levels above the classic mag. Each one of the 7 spokes are tapered and feature sculpted sides with a cut out center for heavy styling that doesn't add weight to the motorcycle. To keep it consistent, we brought the same design philosophy to the rim lip where large pockets have been CNC machined between each in spoke to reduce as much weight as possible while adding bold styling. The 7-VALVE looks good on any machine and is our best-priced option in the lineup.

- ▶ Precision machined from radial forged 6061-T6 aluminum for maximum road durability
- ▶ Structurally tested to meet or exceed DOT, JAS and TUV international load ratings
- ▶ Hub design features a cartridge type hub that includes both bearings that are pre-set and ready to install in minutes
- ▶ Cartridge design hub features both wheel bearings pre-set in one hub for optimum radial and lateral runout accuracy
- ▶ Available in chrome or black anodize finish
- ▶ Matching floating performance rotors are also available





PROCROSS

### PROCROSS

Race inspired design with extreme attention to detail. Lightweight yet engineered to perform and handle anything the road wants to throw at you. Although the inspiration came from the racetrack it doesn't mean we didn't spend countless hours sculpting each "spoke" to ensure it rode the fine line between race and luxury styling.

- ▶ Precision machined from radial forged 6061-T6 aluminum for maximum road durability
- ▶ Structurally tested to meet or exceed DOT, JAS and TUV international load ratings
- ▶ Hub design features a cartridge type hub that includes both bearings that are pre-set and ready to install in minutes
- ▶ Cartridge design hub features both wheel bearings pre-set in one hub for optimum radial and lateral runout accuracy
- ▶ Available in chrome or black anodize finish
- ▶ Matching floating performance rotors are also available





**7-VALVE & PROCROSS WHEELS**

<b>FRONT 18" X 3.5"</b>	<b>7-VALVE CHROME</b>	<b>7-VALVE BLACK</b>	<b>PROCROSS CHROME</b>	<b>PROCROSS BLACK</b>
08-Up FLTR/FLHT/FLHR (NON-ABS)	10302-202-6000	10301-202-6000	10102-202-6000	10101-202-6000
08-Up FLTR/FLHT/FLHR, S/D (NON-ABS)	10302-202-6002	10301-202-6002	10102-202-6002	10101-202-6002
08-Up FLTR/FLHT/FLHR (ABS)	10302-202-6004	10301-202-6004	10102-202-6004	10101-202-6004
08-Up FLTR/FLHT/FLHR, S/D (ABS)	10302-202-6006	10301-202-6006	10102-202-6006	10101-202-6006
00-07 FLTR/FLHT/FLHR	10302-202-6020	10301-202-6020	10102-202-6020	10101-202-6020
00-07 FLTR/FLHT/FLHR, S/D	10302-202-6022	10301-202-6022	10102-202-6022	10101-202-6022
11-17 FLSTN/C (ABS)	10302-202-6060	10301-202-6060	10102-202-6060	10101-202-6060
08-17 FLSTF/C/N	10302-202-6062	10301-202-6062	10102-202-6062	10101-202-6062
00-06 FLST/C/N	10302-202-6064	10301-202-6064	10102-202-6064	10101-202-6064
11-Up XL 48	10302-202-6080	10301-202-6080	10102-202-6080	10101-202-6080
18-Up FATBOB (NON-ABS)	10302-202-6132	10301-202-6132	10102-202-6132	10101-202-6132
18-Up FATBOB (ABS)	10302-202-6130	10301-202-6130	10102-202-6130	10101-202-6130
00-03 FXD/00-07 XL DUAL DISC	10302-202-6036	10301-202-6036	10102-202-6036	10101-202-6036
00-03 FXD/00-07 XL SINGLE DISC	10302-202-6038	10301-202-6038	10102-202-6038	10101-202-6038
04-05 FXD DUAL DISC	10302-202-6082	10301-202-6082	10102-202-6082	10101-202-6082
04-05 FXD SINGLE DISC	10302-202-6084	10301-202-6084	10102-202-6084	10101-202-6084

<b>FRONT 18" X 5.5"</b>	<b>7-VALVE CHROME</b>	<b>7-VALVE BLACK</b>	<b>PROCROSS CHROME</b>	<b>PROCROSS BLACK</b>
08-Up FLTR/FLHT/FLHR (NON-ABS)	10302-203-6000	10301-203-6000	10102-203-6000	10101-203-6000
08-Up FLTR/FLHT/FLHR, S/D (NON-ABS)	10302-203-6002	10301-203-6002	10102-203-6002	10101-203-6002
08-Up FLTR/FLHT/FLHR (ABS)	10302-203-6004	10301-203-6004	10102-203-6004	10101-203-6004
08-Up FLTR/FLHT/FLHR, S/D (ABS)	10302-203-6006	10301-203-6006	10102-203-6006	10101-203-6006
18-Up FATBOB (NON-ABS) FXFB/S	10302-203-6132	10301-203-6132	10102-203-6132	10101-203-6132
18-Up FATBOB (ABS) FXFB/S	10302-203-6130	10301-203-6130	10102-203-6130	10101-203-6130

<b>FRONT 21" X 3.5"</b>	<b>7-VALVE CHROME</b>	<b>7-VALVE BLACK</b>	<b>PROCROSS CHROME</b>	<b>PROCROSS BLACK</b>
08-Up FLTR/FLHT/FLHR, (NON-ABS)	10302-204-6000	10301-204-6000	10102-204-6000	10101-204-6000
08-Up FLTR/FLHT/FLHR, S/D (NON-ABS)	10302-204-6002	10301-204-6002	10102-204-6002	10101-204-6002
08-Up FLTR/FLHT/FLHR, (ABS)	10302-204-6008	10301-204-6008	10102-204-6008	10101-204-6008
08-Up FLTR/FLHT/FLHR, S/D (ABS)	10302-204-6010	10301-204-6010	10102-204-6010	10101-204-6010
00-07 FLTR/FLHT/FLHR,	10302-204-6020	10301-204-6020	10102-204-6020	10101-204-6020
00-07 FLTR/FLHT/FLHR, S/D	10302-204-6022	10301-204-6022	10102-204-6022	10101-204-6022
07-17 FXST	10302-204-6056	10301-204-6056	10102-204-6056	10101-204-6056
11-17 FXST, (ABS)	10302-204-6058	10301-204-6058	10102-204-6058	10101-204-6058
11-17 FLSTN/C, (ABS)	10302-204-6060	10301-204-6060	10102-204-6060	10101-204-6060
08-17 FLSTF/C/N (Exc.18 FLSTF)	10302-204-6062	10301-204-6062	10102-204-6062	10101-204-6062
00-06 FXST/00-05 FXDWG	10302-204-6066	10301-204-6066	10102-204-6066	10101-204-6066
08-10 FXDF	10302-204-6032	10301-204-6032	10102-204-6032	10101-204-6032
08-10 FXDF, ABS	10302-204-6034	10301-204-6034	10102-204-6034	10101-204-6034
06-07 FXDWG	10302-204-6040	10301-204-6040	10102-204-6040	10101-204-6040
08-17 FXD B/C/L, S/D	10302-204-6042	10301-204-6042	10102-204-6042	10101-204-6042
13-17 FXSB, (NON-ABS)	10302-204-6050	10301-204-6050	10102-204-6050	10101-204-6050
13-17 FXSB, ABS	10302-204-6052	10301-204-6052	10102-204-6052	10101-204-6052
00-06 FXSTS	10302-204-6068	10301-204-6068	10102-204-6068	10101-204-6068
00-03 FXD/00-07 XL DUAL DISC	10302-204-6036	10301-204-6036	10102-204-6036	10101-204-6036
00-03 FXD/00-07 XL SINGLE DISC	10302-204-6038	10301-204-6038	10102-204-6038	10101-204-6038
04-05 FXD DUAL DISC	10302-204-6082	10301-204-6082	10102-204-6082	10101-204-6082
04-05 FXD SINGLE DISC	10302-204-6084	10301-204-6084	10102-204-6084	10101-204-6084

<b>FRONT 23" X 3.5"</b>	<b>7-VALVE CHROME</b>	<b>7-VALVE BLACK</b>	<b>PROCROSS CHROME</b>	<b>PROCROSS BLACK</b>
08+ FLTR/FLHT/FLHR (NON-ABS)	10302-205-6000	10301-205-6000	10102-205-6000	10101-205-6000
08+ FLTR/FLHT/FLHR, S/D (NON-ABS)	10302-205-6002	10301-205-6002	10102-205-6002	10101-205-6002
08+ FLTR/FLHT/FLHR (ABS)	10302-205-6012	10301-205-6012	10102-205-6012	10101-205-6012
08+ FLTR/FLHT/FLHR, S/D (ABS)	10302-205-6014	10301-205-6014	10102-205-6014	10101-205-6014

<b>FRONT 23" X 3.5" [continued]</b>	<b>7-VALVE CHROME</b>	<b>7-VALVE BLACK</b>	<b>PROCCROSS CHROME</b>	<b>PROCCROSS BLACK</b>
00-07 FLTR/FLHT/FLHR	10302-205-6020	10301-205-6020	10102-205-6020	10101-205-6020
00-07 FLTR/FLHT/FLHR, S/D	10302-205-6022	10301-205-6022	10102-205-6022	10101-205-6022
07-17 FXST	10302-205-6056	10301-205-6056	10102-205-6056	10101-205-6056
11-17 FLSTN/C	10302-205-6060	10301-205-6060	10102-205-6060	10101-205-6060
08-17 FLSTF/C/N	10302-205-6062	10301-205-6062	10102-205-6062	10101-205-6062
00-06 FXST/00-05 FXDWG	10302-205-6066	10301-205-6066	10102-205-6066	10101-205-6066
13-17 FXSB	10302-205-6050	10301-205-6050	10102-205-6050	10101-205-6050
00-06 FXSTS	10302-205-6068	10301-205-6068	10102-205-6068	10101-205-6068

<b>FRONT 26" X 3.5"</b>	<b>7-VALVE CHROME</b>	<b>7-VALVE BLACK</b>	<b>PROCCROSS CHROME</b>	<b>PROCCROSS BLACK</b>
08-Up FLTR/FLHT/FLHR (NON-ABS)	10302-206-6000	10301-206-6000	10102-206-6000	10101-206-6000
08-Up FLTR/FLHT/FLHR, S/D, NON-ABS	10302-206-6002	10301-206-6002	10102-206-6002	10101-206-6002
08-Up FLTR/FLHT/FLHR (ABS)	10302-206-6016	10301-206-6016	10102-206-6016	10101-206-6016
08-Up FLTR/FLHT/FLHR S/D (ABS)	10302-206-6018	10301-206-6018	10102-206-6018	10101-206-6018
00-07 FLTR/FLHT/FLHR	10302-206-6020	10301-206-6020	10102-206-6020	10101-206-6020
00-07 FLTR/FLHT/FLHR, S/D	10302-206-6022	10301-206-6022	10102-206-6022	10101-206-6022

<b>REAR 17" X 6.25"</b>	<b>7-VALVE CHROME</b>	<b>7-VALVE BLACK</b>	<b>PROCCROSS CHROME</b>	<b>PROCCROSS BLACK</b>
09-Up FLT (NON-ABS)	10302-201-6500	10301-201-6500	10102-201-6500	10101-201-6500
09-Up FLT (ABS)	10302-201-6501	10301-201-6501	10102-201-6501	10101-201-6501
06 FXST/2006 FLSTFSE	10302-201-6506	10301-201-6506	10102-201-6506	10101-201-6506
07 FXST/FLSTF	10302-201-6507	10301-201-6507	10102-201-6507	10101-201-6507
08-17 FXST/08-10 FLSTF/11-17FLSTF/FB/SB	10302-201-6509	10301-201-6509	10102-201-6509	10101-201-6509
11-13 FXST/FLSTF/FB/SB (ABS)	10302-201-6510	10301-201-6510	10102-201-6510	10101-201-6510

<b>REAR 18" X 3.5"</b>	<b>7-VALVE CHROME</b>	<b>7-VALVE BLACK</b>	<b>PROCCROSS CHROME</b>	<b>PROCCROSS BLACK</b>
08 FLTR/FLHT/FLHR (NON-ABS)	10302-202-6502	10301-202-6502	10102-202-6502	10101-202-6502
08 FLTR/FLHT/FLHR (ABS)	10302-202-6503	10301-202-6503	10102-202-6503	10101-202-6503
02-07 FLT	10302-202-6504	10301-202-6504	10102-202-6504	10101-202-6504
00-01 FLT	10302-202-6505	10301-202-6505	10102-202-6505	10101-202-6505
08-17 FXST/FLST/FXS/FLS	10302-202-6509	10301-202-6509	10102-202-6509	10101-202-6509
11-17 FXST/FLSTN/C (ABS)	10302-202-6510	10301-202-6510	10102-202-6510	10101-202-6510
00-07 FLST	10302-202-6512	10301-202-6512	10102-202-6512	10101-202-6512
11-Up XL,48	10302-202-6519	10301-202-6519	10102-202-6519	10101-202-6519
00-05 FXD/FXDWG	10302-202-6514	10301-202-6514	10102-202-6514	10101-202-6514

<b>REAR 18" X 5.5"</b>	<b>7-VALVE CHROME</b>	<b>7-VALVE BLACK</b>	<b>PROCCROSS CHROME</b>	<b>PROCCROSS BLACK</b>
09-Up FLT 180mm (NON-ABS)	10302-203-6500	10301-203-6500	10102-203-6500	10101-203-6500
09-Up FLT 180mm (ABS)	10302-203-6501	10301-203-6501	10102-203-6501	10101-203-6501
08 FLT 180mm (NON-ABS)	10302-203-6502	10301-203-6502	10102-203-6502	10101-203-6502
08 FLT 180mm (ABS)	10302-203-6503	10301-203-6503	10102-203-6503	10101-203-6503
08-17 FXST	10302-203-6509	10301-203-6509	10102-203-6509	10101-203-6509
11-17 FXST/FLSTF/FB/SB (ABS)	10302-203-6510	10301-203-6510	10102-203-6510	10101-203-6510
06-07 FXD	10302-203-6515	10301-203-6515	10102-203-6515	10101-203-6515
08-17 FXD	10302-203-6516	10301-203-6516	10102-203-6516	10101-203-6516
18-Up FATBOB (NON-ABS) FXFB/S	10302-203-6631	10301-203-6631	10102-203-6631	10101-203-6631
18-Up FATBOB (ABS) FXFB/S	10302-203-6630	10301-203-6630	10102-203-6630	10101-203-6630



NEW

Y-SPOKE

### Y-SPOKE

The Y-SPOKE wheel design is focused on performance, high level CNC machined detail, and custom anodize finishes. The result is a clean overall style that becomes more and more aggressive the closer you get. Each carved out lightweight wheel is anodized in a color from a selection of proprietary finishes.

- ▶ Precision machined from radial forged 6061-T6 aluminum for maximum road durability
- ▶ Structurally tested to meet or exceed DOT, JAS and TUV international load ratings
- ▶ Accepts Ness cartridge type hubs that includes both bearings That are pre-set and ready to install in minutes
- ▶ Available in black, titanium, red, gold, blue & orange anodize
- ▶ Accepts Arlen Ness Rotor Adapters with factory or aftermarket rotors/ discs
- ▶ Available sizes: 21" x 3.5" & 18" x 5.5"



FRONT 21" X 3.5"	Y-SPOKE BLACK
08-Up FLTR/FLHT/FLHR (NON-ABS)	10403-204-6000
08-Up FLTR/FLHT/FLHR, S/D (NON-ABS)	10403-204-6002
08-Up FLTR/FLHT/FLHR (ABS)	10403-204-6008
08-Up FLTR/FLHT/FLHR S/D (ABS)	10403-204-6010
00-07 FLTR/FLHT/FLHR	10403-204-6020
00-07 FLTR/FLHT/FLHR, S/D	10403-204-6022
07-Up FXST	10403-204-6056
11-17 FXST, ABS	10403-204-6058
11-17 FLSTN/C (ABS)	10403-204-6060
08-17 FLSTF/C/N	10403-204-6062
00-06 FXST/00-05 FXDWG	10403-204-6066
08-10 FXDF	10403-204-6032
08-10 FXDF, ABS	10403-204-6034
06-07 FXDWG	10403-204-6040
08-17 FXD B/C/L, S/D	10403-204-6042
13-17 FXSB	10403-204-6050
13-17 FXSB, ABS	10403-204-6052
00-06 FXSTS	10403-204-6068
00-03 FXD/00-07 XL DUAL DISC	10403-204-6036
00-03 FXD/00-07 XL SINGLE DISC	10403-204-6038
04-05 FXD DUAL DISC	10403-204-6082
04-05 FXD SINGLE DISC	10403-204-6084

FRONT 18" X 5.5"	Y-SPOKE BLACK
08-Up FLTR/FLHT/FLHR (NON-ABS)	10403-203-6000
08-Up FLTR/FLHT/FLHR, S/D (NON-ABS)	10403-203-6002
08-Up FLTR/FLHT/FLHR (ABS)	10403-203-6004
08-Up FLTR/FLHT/FLHR, S/D (ABS)	10403-203-6006
18-Up FATBOB (ABS) FXFB/S	10403-203-6130
18-Up FATBOB (NON-ABS) FXFB/S	10403-203-6132

REAR 18" X 5.5"	Y-SPOKE BLACK
09-Up FLT 180MM (NON-ABS)	10403-203-6500
09-Up FLT 180MM (ABS)	10403-203-6501
08 FLT 180MM (NON-ABS)	10403-203-6502
08 FLT 180MM (ABS)	10403-203-6503
08-17 FXST	10403-203-6509
11-17 FXST/FLSTF/FB/SB (ABS)	10403-203-6510
06-07 FXD	10403-203-6515
08-UP FXD	10403-203-6516
18-Up FATBOB (ABS) FXFB/S	10403-203-6630
18-Up FATBOB (NON-ABS) FXFB/S	10403-203-6631



Y-Spoke Titanium Rims, Page #37

FRONT HUB KITS



Dual Disc, Black



Dual Disc, Chrome



Single Disc, Black



Single Disc, Chrome

REAR HUB KITS



Rear, Black



Rear, Chrome



Rear Cush Drive, Black



Rear Cush Drive, Chrome

ARLEN NESS CARTRIDGE HUBS

- ▶ These billet aluminum hub kits are designed for Arlen Ness forged billet rims
- ▶ Cartridge hub design features wheel bearings pre-set in one hub for optimum radial and lateral runout accuracy
- ▶ Lightweight coped design provides form and function
- ▶ Each hub kit includes everything you need for ABS or non-ABS Harley applications regardless of your wheel diameter
- ▶ Hub kits mount to your Arlen Ness forged rims in minutes with basic tools offering excellent flexibility for stock or custom applications, and allowing all sizes to be available for most applications
- ▶ Available in Chrome or Black anodized finish, each hub kit includes everything needed for simple installation
- ▶ Designed for 7-Valve, Procross, Y-Spoke (will not work w/ Drift & Flare 5 styles)

FRONT HUBS	BLACK	CHROME	REAR HUBS	BLACK	CHROME
Hub Kit 08-Up FLT FT Dual	71-600	71-601	Hub Kit 09-Up FLT RR	71-700	71-701
Hub Kit 08-19 FLT FT Single	71-602	71-603	Hub Kit 08-17 FXD RR	71-702	71-703
Hub Kit 00-07 FLT FT Dual	71-604	71-605	Hub Kit 18-Up Fatbob RR	71-704	71-705
Hub Kit 00-07 FLT FT Single	71-606	71-607	Hub Kit 02-07 FLT RR	71-706	71-707
Hub Kit 2008 FXD FT Single	71-608	71-609	Hub Kit 08-17 FXST RR	71-712	71-713
Hub Kit 08-10 FXDF FT Dual	71-610	71-611	Hub Kit 11-Up XL RR	71-726	71-727
Hub Kit 08-17 FLST FT Single	71-612	71-613			
Hub Kit 18-Up Fatbob FT Dual	71-614	71-615			
Hub Kit 00-03 FXD/00-07 FT Dual	71-616	71-617			
Hub Kit 00-03 FXD/00-07 FT Single	71-618	71-619			
Hub Kit 06-07 FXD FT Single	71-620	71-621			
Hub Kit 08-17 FXD/B/C/L FT Single	71-622	71-623			
Hub Kit 14-17 FXDL FT Dual	71-624	71-625			
Hub Kit 07-14 FXST FT Single	71-628	71-629			
Hub Kit 11-17 FXST FT Single	71-630	71-631			
Hub Kit 00-06 FLST FT Single	71-632	71-633			
Hub Kit 00-06 FLST/00-05 FXD W	71-634	71-635			
Hub Kit 00-06 FXSTS FT Single	71-636	71-637			
Hub Kit 11-Up XL/48 FT Single	71-638	71-639			

\*NOTE: Hubs listed accept factory or aftermarket hub mounted 5-bolt hub mounted rotors (3.25" bolt circle)

- ▶ Choose from Procross, 7-Valve & Y-Spoke forged billet rims
- ▶ All rims are CNC machined from radial forged 6061-T6 aluminum for maximum road durability and strength-to-weight ratio
- ▶ Features a rolled rim lip for the custom look and detailed CNC machine work from the center of the hub to the edge of the rim
- ▶ Each rim can be used on both front and/or rear of the motorcycle when correct hub kit is installed
- ▶ Structurally tested to meet or exceed DOT, JAS and TUV international load ratings
- ▶ Rims accept Arlen Ness Hub Kits, which allows full wheels to be assembled in minutes with basic tools
- ▶ Available in : 21" x 3.50"/23" x 3.50"/26" x 3.5"/18" x 3.50"/18" x 5.5"/17" x 6.25" sizes
- ▶ Designed specifically for Arlen Ness Cartridge Hubs

**PROCCROSS**

	BLACK	CHROME
Procross Rim 17" x 6.25"	71-500	71-510
Procross Rim 18" x 3.50"	71-501	71-511
Procross Rim 18" x 5.50"	71-502	71-512
Procross Rim 21" x 3.50"	71-503	71-513
Procross Rim 23" x 3.50"	71-504	71-514
Procross Rim 26" x 3.50"	71-505	71-515

**7-VALVE**

	BLACK	CHROME
7-Valve Rim 17" x 6.25"	71-520	71-530
7-Valve Rim 18" x 3.50"	71-521	71-531
7-Valve Rim 18" x 5.50"	71-522	71-532
7-Valve Rim 21" x 3.50"	71-523	71-533
7-Valve Rim 23" x 3.50"	71-524	71-534
7-Valve Rim 26" x 3.50"	71-525	71-535

**Y-SPOKE**

	BLACK	TITANIUM	RED	ORANGE	BLUE	GOLD
Y-Spoke Rim 18" x 5.50"	71-550	71-552	71-548	71-550	71-544	71-546
Y-Spoke Rim 21" x 3.50"	71-541	71-553	71-549	71-551	71-545	71-547



33-10004-103

### FLARE 5 & DRIFT FRONT BRAKE ROTORS

- ▶ Specially designed performance brake rotors designed for Flare 5 & Drift premium series front wheels
- ▶ Each jagged style rotor is made from 420 Stainless Steel
- ▶ Engineered to disperse heat and perform consistently in all braking scenarios  
14" & 11.8" diameters available
- ▶ Designed specifically for Flare 5 & Drift front wheels
- ▶ Brake calipers or brake caliper adapter brackets are available separately for 14" diameter rotors

#### FLARE 5 & DRIFT FRONT ROTORS

**33-10004-103** 14" Flare 5

**33-10204-103** 14" Drift

**33-10004-102** 11.8" Flare 5/Drift

**NOTE:** Check front fender clearance. 14" rotor's are intended for use with Arlen Ness or factory front fenders



FLARE 5, 14"



DRIFT, 14"



33-10001-202

**FLARE 5 & DRIFT REAR BRAKE ROTORS**

- ▶ 2-piece floating brake rotors
- ▶ CNC machined billet inner carrier
- ▶ Jagged 420 stainless steel outer brake disc is cut and drilled to efficiently disperse heat and perform consistently in all braking scenarios 11.8" & 11.5" diameters
- ▶ Designed for Flare 5 & Drift rear wheels, but can be used as a front or rear rotor on most all factory or aftermarket HD fitment wheels

**FLARE 5 ROTORS**

**33-10002-202** 11.8" Rear, Chrome

**33-10001-202** 11.8" Rear, Black

**33-10002-201** 11.5" Rear, Chrome

**33-10001-201** 11.5" Rear, Black

**DRIFT ROTORS**

**33-10202-202** 11.8" Rear, Chrome

**33-10201-202** 11.8" Rear, Black

**33-10202-201** 11.5" Rear, Chrome

**33-10201-201** 11.5" Rear, Black



FLARE 5 , Rear



DRIFT , Rear





33-10102-203

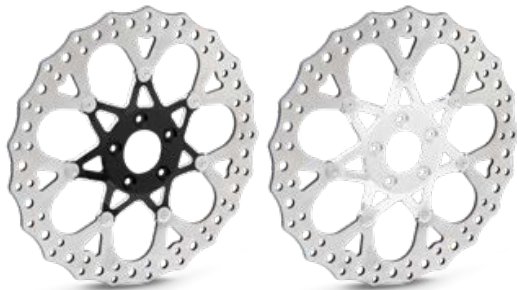

14"



PROCROSS

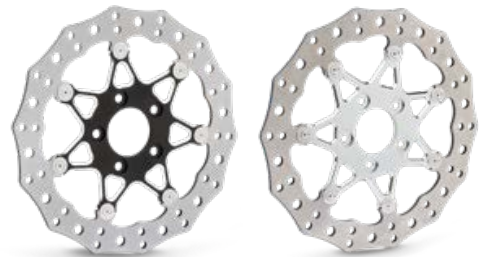

11.5 / 11.8"



7-VALVE

### PERFORMANCE BRAKE ROTORS

- ▶ 2-piece floating brake rotor
- ▶ CNC machined billet inner carrier
- ▶ Jagged style 420 stainless steel outer band
- ▶ Stainless outer ring is cut and drilled to efficiently disperse heat and perform consistently in all braking scenarios

- ▶ Available in 11.5", 11.8" and 14" sizes
- ▶ 14" rotor requires the use of Ness Caliper Adapter Bracket or Ness 14" brake calipers
- ▶ Sold individually

#### PROCROSS ROTORS

33-10102-202	11.8" ProCross, Chrome
33-10101-202	11.8" ProCross, Black
33-10102-201	11.5" ProCross, Chrome
33-10101-201	11.5" ProCross, Black
33-10102-203	14" ProCross, Chrome
33-10101-203	14" ProCross, Black

#### 7-VALVE ROTORS

33-10302-202	11.8" 7-Valve, Chrome
33-10301-202	11.8" 7-Valve, Black
33-10302-201	11.5" 7-Valve, Chrome
33-10301-201	11.5" 7-Valve, Black
33-10302-203	14" 7-Valve, Chrome
33-10301-203	14" 7-Valve, Black

**NOTE:** 14" ProCross & 7-Valve rotors for Softail®/Dyna® applications require the use of Arlen Ness 14" Brake Calipers or Caliper Adapter Brackets



FACTORY ROTOR ADAPTERS FOR 14-UP FLT

**FLT ROTOR ADAPTERS**

- ▶ Allows the use of factory 14-Up FLT spoke mounted rotors on aftermarket billet wheels
- ▶ Forged from billet aluminum then CNC machined to perfection
- ▶ Available in two applications: "Ness Specific" which matches the cartridge hub design found on Ness hubs & Universal, which fits on any aftermarket 5-bolt hub wheel
- ▶ Each rotor adapter includes hub mounting hardware
- ▶ Choose from chrome or black anodize finish factory floating rotor bolt hardware

**14-UP FLT ROTOR ADAPTERS**

- 33-100** Spoke Mount, Universal Fitment, Black
- 33-101** Spoke Mount, Universal Fitment, Chrome
- 33-102** Spoke Mount, Ness Wheel, Black
- 33-103** Spoke Mount, Ness Wheel, Chrome

**NOTE:** Not For Drift or Flare 5 wheels



33-102



33-103



33-100



33-101

**14" BRAKE CALIPER ADAPTER BRACKETS**

- ▶ Brake caliper adaptor brackets that relocate factory brake calipers to the proper position for the use of 14" rotors
- ▶ CNC machined from billet aluminum
- ▶ Black anodize finish
- ▶ Hardware included
- ▶ Sold individually

**ADAPTER BRACKETS**

- 02-976** 14" Caliper Bracket Kit, Left, 08-Up FLT
- 02-977** 14" Caliper Bracket Kit, Right, 08-Up FLT
- 02-978** 14" Caliper Bracket Kit, Left, 00-07 FLT
- 02-979** 14" Caliper Bracket Kit, Right, 00-07 FLT
- 02-974** 14" Caliper Bracket Kit, Left, Softail®/Dyna® equipped w/ 11.5" Factory Rotors
- 02-975** 14" Caliper Bracket Kit, Left, Softail®/Dyna® equipped / 11.8" Factory Rotors

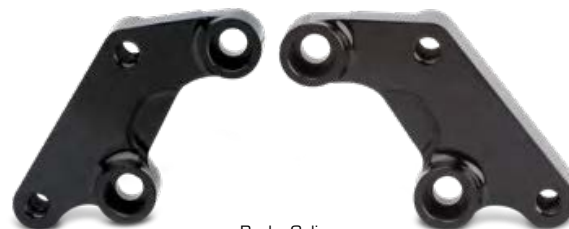

Brake Caliper Adapter Brackets



JAGGED BRAKE ROTORS



02-787

**JAGGED PERFORMANCE FLOATING BRAKE ROTORS**

- ▶ High performance Floating Brake Rotors are designed to enhance braking performance, and style, of factory or aftermarket wheels
- ▶ 420 Stainless construction, drilled for optimum performance and heat dispersion
- ▶ 11.8" spoke mounted front rotors are designed to fit factory front FLT touring and other models equipped with spoke mounted 11.8" factory rotors
- ▶ 11.5" and 11.8" are universal and can be used on the front or rear of HD models equipped with 5-bolt hub mounted factory rotors
- ▶ Rear FLT specific rotors feature a heavy duty construction and the proper thickness for the rear FLT applications
- ▶ Utilizes factory rotor hardware
- ▶ Sold individually

**JAGGED ROTORS**

- |               |  |
|---------------|--|
| <b>02-786</b> | 11.5" Jagged Brake Rotor; Hub Mount                      |
| <b>02-787</b> | 11.8" Jagged Brake Rotor; Hub Mount                      |
| <b>02-788</b> | 11.8" Jagged Brake Rotor; Spoke Mount<br>FLT, Front only |
| <b>02-785</b> | 11.8" Jagged Brake Rotor; FLT, Rear only                 |



Jagged Hub Mount



Jagged Spoke Mount



02-787



08-788



02-786



02-785



02-785



15" BIG BRAKE ROTOR KIT

**15" BIG BRAKE ROTOR KITS HUB MOUNTED ROTORS**

- ▶ 15" Big Brake Rotor Kits drastically improve braking performance as well upgrade the style of your factory front wheel
- ▶ 420 stainless steel, drilled for optimum performance and heat dispersion
- ▶ Utilizes factory brake caliper, rotor hardware and brake hose
- ▶ Easy bolt-on installation, no need to re-bleed the brake system
- ▶ Designed to fit HD models with factory fork legs & wheels, equipped with standard hub mounted rotors
- ▶ Each kit includes a 15" rotor, caliper adapter bracket and all necessary hardware

**15" BIG BRAKE KIT**

02-990	Jagged 00-05 Dyna®/00-14 Softail® models with hub mounted 11.5 rotor and 18" or larger wheel, LH, Black
02-992	Jagged 00-05 Dyna®/00-14 Softail®/00-05 XL models with hub mounted 11.5 rotor and 18" or larger wheel, RH, Black
02-994	Jagged 06-17 Dyna®/15-17 Softail® models with hub mounted 11.8 rotor and 18" or larger wheel, LH, Black
02-995	Jagged 06-17 Dyna®/15-17 Softail® models with hub mounted 11.8 rotor and 18" or larger wheel, RH, Black
02-965*	00-05 Dyna®/ 00-17 Softail® models with hub mounted 11.5 rotor and 18" or larger wheel, LH
02-967*	00-05 Dyna®/ 00-17 Softail® models with hub mounted 11.5 rotor and 18" or larger wheel, RH
02-966	06-13 Sportster® models with 11.5" hub mounted rotor and 19" or larger wheel, LH
02-973*	06-17 Dyna®/15-17 Softail® models with 11.8 stock hub mounted rotor, RH
02-972*	06-17 Dyna®/15-17 Softail® models with 11.8 stock hub mounted rotor, LH
02-969	14-Up Sportster® models with 11.5" hub mounted rotor, LH
02-996	18 FLXR/FXBB OS Jagged rotor, LH
02-983	BG BRK 15 rotor, 18 FXLR, LH



02-966



15" Hub Mount



02-966



02-990

**NOTE:** Designed for use with factory fork legs & calipers, will not work with Arlen Ness "Hot Leg" Fork Legs. \*Does not fit FLD (Switchback) models. Will not work on 2018 Softail® models



15" BIG BRAKE ROTOR KIT



02-991/02-993

### 15" BIG BRAKE ROTOR KITS FOR FXD SPOKE MOUNTED ROTORS

- ▶ 15" Big Brake rotor kits drastically improve braking performance as well upgrade the style of your factory front wheel
- ▶ Each 15" floating rotor is constructed from 420 stainless steel, and is drilled for optimum performance and heat dispersion
- ▶ Available in a Jagged rotor style
- ▶ Utilizes factory brake caliper, rotor hardware and brake hose. Easy bolt-on installation, no need to re-bleed the brake system
- ▶ Designed to fit HD models with factory wheels equipped w/ spoke mounted rotors
- ▶ Each kit includes 15" rotor, caliper adapter bracket and all necessary hardware

#### 15" BIG BRAKE KIT

- 02-991** Jagged 06-17 Dyna® models with spoke mount rotor, w/OEM cast wheel, LH
- 02-993** Jagged 06-17 Dyna® models with spoke mount rotor, w/OEM cast wheel, RH



15" FOR FXD



02-991

**14" BIG BRAKE ROTOR KITS FOR 14-UP FLT TOURING, SPOKE MOUNTED ROTORS**

- ▶ 14" Big Brake Rotor Kits drastically improve braking performance as well upgrade the style of your factory front wheel
- ▶ Each 14" floating rotor is constructed from 420 stainless steel, and is drilled for optimum performance and heat dispersion
- ▶ Billet brake caliper adapters are included in each kit to properly relocate your factory caliper to the proper position
- ▶ Available in Standard or Jagged rotor styles
- ▶ Utilizes factory brake caliper, rotor hardware and brake hose
- ▶ Easy bolt-on installation, no need to re-bleed the brake system
- ▶ Designed to fit 14-Up FLT Touring models with factory wheels equipped with spoke mounted rotors
- ▶ Each kit includes 14" rotor, caliper adapter bracket and all necessary hardware

**14" BIG BRAKE KIT STANDARD**

**02-962** 14-Up FLHR/FLHX/FLT models with factory cast wheel, Standard, LH

**02-963** 14-Up FLHR/FLHX/FLT models with factory cast wheel, Standard, RH

**14" BIG BRAKE KIT JAGGED**

**02-950** 14-Up FLHR/FLHX/FLT models with factory cast wheel, Jagged, LH

**02-951** 14-Up FLHR/FLHX/FLT models with factory cast wheel, Jagged, RH



02-962/02-963



14" FOR 14-Up FLT

02-963

02-951

**14" BIG BRAKE ROTOR KITS FOR 18-20 & 00-13 FLT TOURING MODELS, HUB MOUNTED ROTORS**

- ▶ 14" Big Brake rotor kits drastically improve braking performance as well upgrade the style of your factory front wheel
- ▶ Each 14" floating rotor is constructed from 420 stainless steel, and is drilled for optimum performance and heat dispersion
- ▶ Billet brake caliper adapters are included in each kit to properly relocate your factory caliper to the proper position
- ▶ Utilizes factory brake caliper, rotor hardware and brake hose. Easy bolt-on installation, no need to re-bleed the brake system
- ▶ Designed to fit 2000 - 2013 & 18-20 FLT Touring models with factory wheels equipped with standard hub mounted rotors
- ▶ Each kit includes 14" rotor, caliper adapter bracket and all necessary hardware
- ▶ Sold individually

**14" BIG BRAKE KIT**

**02-910** 18-20 FLHRXS/FLHXS/FLTRXS, 08-13 FLHT/FLHX/FLTR & 08-16 FLHR w/ 17" or larger front wheels, LH

**02-911** 18-20 FLHRXS/FLHXS/FLTRXS, 08-13 FLHT/FLHX/FLTR & 08-16 FLHR w/ 17" or larger front wheels, RH

**02-920** 00-07 FLHR/FLHX/FLT models w/ 17" or larger front wheel, LH

**02-921** 00-07 FLHR/FLHX/FLT models w/ 17" or larger front wheel, RH



02-910/02-911



14" FOR 00-13 FLT

**NOTE:** Designed to work with 17" or larger front wheels with hub mounted rotors



6-PISTON BLACK FRONT BRAKE CALIPERS



6-PISTON, 14"



6-PISTON 11.8"



6-PISTON, TITANIUM

### 6-PISTON DIFFERENTIAL BORE BRAKE CALIPERS

- ▶ 6-piston Differential Bore Brake Calipers CNC machined from billet aluminum
- ▶ 3D sculptured caliper design
- ▶ Extremely stiff under stress, ensuring precise and consistent braking performance
- ▶ Cooling fins are machined into the inner caliper halves to help disperse heat
- ▶ Compatible with ABS & non-ABS applications
- ▶ Available for 11.8" and 14" brake applications
- ▶ Chrome, black anodize, red, blue, gold & titanium finishes available
- ▶ Each caliper includes DP brake pads, bleeder screw, banjo bolt, sealing washers, mounting hardware and shim kit
- ▶ Fitment: 08-Up FLT/18-20 Softail®/06-17 FLST/06-17 FXD/14-Up XL

### 6-PISTON CALIPERS

	14" LEFT	14" RIGHT	11.8" LEFT	11.8" RIGHT
Chrome	02-210	02-212	02-214	02-216
Black	02-211	02-213	02-215	02-217
Blue	02-200	02-203	02-224	02-227
Red	02-202	02-205	02-226	02-229
Gold	02-201	02-204	02-225	02-228
Titanium	02-206	02-207	02-218	02-219

**NOTE:** For 11.5" applications, add 11.8" diameter brake rotor to use 11.8" calipers

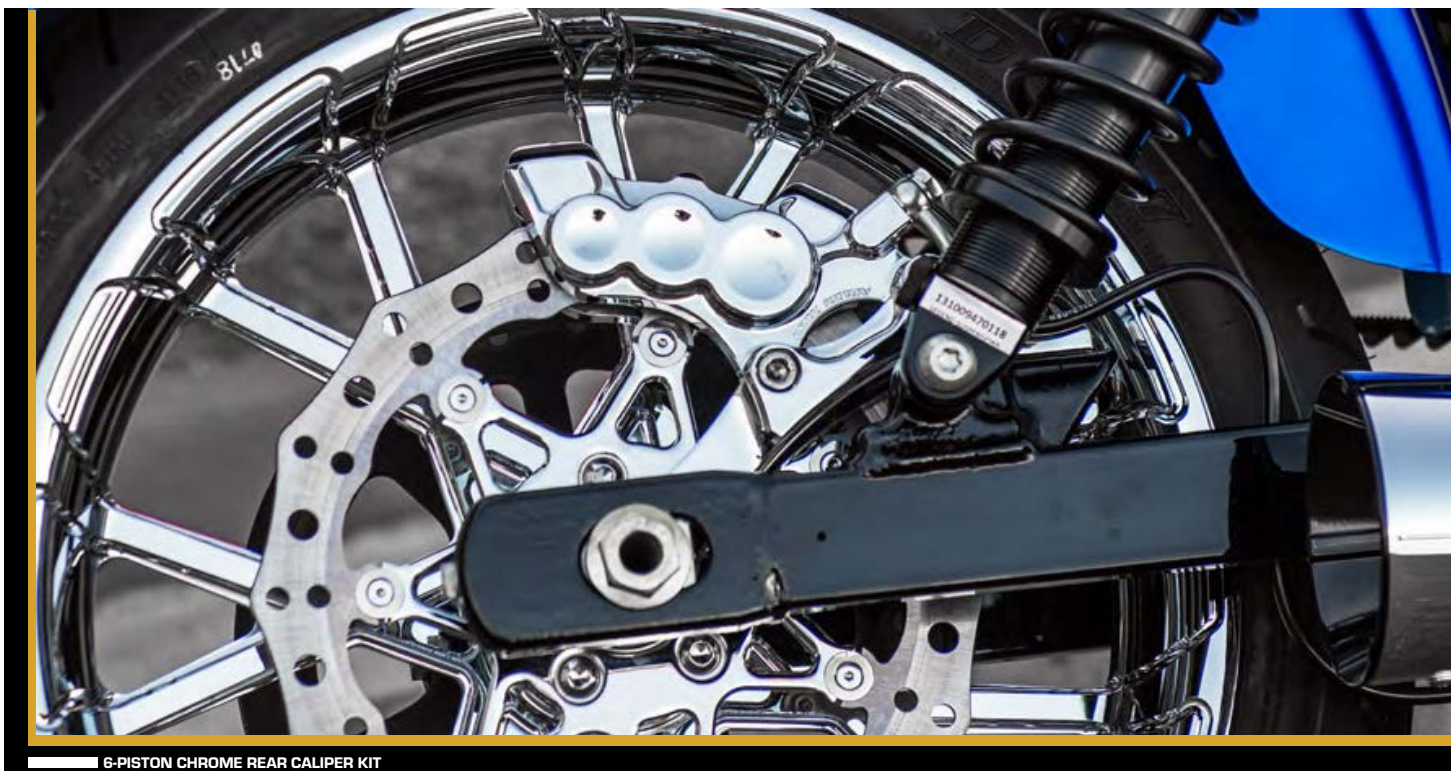

6-PISTON CHROME REAR CALIPER KIT

**REAR 6-PISTON DIFFERENTIAL BORE BRAKE CALIPER KITS**

- ▶ Rear brake caliper kits that combine our 6-Piston Differential Bore Brake Calipers with specially machined rear caliper brackets
- ▶ Caliper brackets are CNC machined from billet aluminum
- ▶ Compatible with ABS & non-ABS applications
- ▶ Available for 11.8" rear brake applications
- ▶ Each Rear Caliper Kit includes a rear caliper bracket, DP brake pads, bleeder screw, banjo bolt, sealing washers, mounting hardware and shim kit
- ▶ Rear brake caliper brackets are available individually, choose your proper application and favorite front caliper finish
- ▶ Fitment: 08-Up FLT/08-17 FXST & FLST/08-17 FXD

**6-PISTON REAR, 08-UP FLT\***

02-302 Rear Caliper, Chrome

02-303 Rear Caliper, Black

**6-PISTON REAR, 08-17 FXST/FLST\***

02-310 Rear Caliper, Chrome

02-311 Rear Caliper, Black

**6-PISTON REAR, 08-17 FXD\***

02-322 Rear Caliper, Chrome

02-323 Rear Caliper, Black

**REAR CALIPER BRACKETS\***

02-300 08-Up FLT, Chrome

02-301 08-Up FLT Touring, Black

02-321 08-17 FXD

\*NOTE: For 11.5" applications, add 11.8" diameter brake rotor to use 11.8" calipers



6-PISTON Rear, FLT/FXD



6-PISTON Rear, FXST/FLST



Rear Caliper Bracket





4-PISTON FRONT BRAKE CALIPERS



4-PISTON, 11.8"



4-PISTON, Rear View



4-PISTON, Rear

#### 4-PISTON BRAKE CALIPERS

- ▶ 4-piston brake calipers CNC machined from billet aluminum
- ▶ 3D sculptured caliper design
- ▶ Extremely stiff under stress, ensuring precise and consistent braking performance
- ▶ Cooling fins are machined into the inner caliper halves help disperse heat
- ▶ Compatible with ABS & non-ABS applications
- ▶ Available for 11.8" brake applications
- ▶ Chrome and black finishes available
- ▶ Each Caliper includes DP brake pads, bleeder screw, banjo bolt, sealing washers, mounting hardware and shim kit
- ▶ Fitment: 08-Up FLT/18-20 Softail®/06-17 FLST/06-17 FXD/14-Up XL

#### 4-PISTON CALIPERS

**02-220** Front 4-Piston Left, Chrome

**02-221** Front 4-Piston Left, Black

**02-222** Front 4-Piston Right, Chrome

**02-223** Front 4-Piston Right, Black

#### REAR 4-PISTON BRAKE CALIPER KITS

- ▶ Rear Brake Caliper Kits that combine our 4-piston brake calipers with specially designed rear caliper brackets
- ▶ Rear Caliper bracket is CNC machined from billet aluminum
- ▶ Compatible with ABS & non-ABS applications
- ▶ Available for 11.8" brake applications
- ▶ Each Rear Caliper Kit includes a caliper, brackets, DP brake pads, bleeder screw, banjo bolt, sealing washers, mounting hardware and shim kit
- ▶ Fitment: 08-Up FLT/08-17 FXST & FLAST/08-17 FXD

#### 4-PISTON REAR 08-UP FLT\*

**02-304** 4-Piston Rear, Chrome

**02-305** 4-Piston Rear, Black

#### 4-PISTON REAR 08-17 FXD\*

**02-324** 4-Piston Rear, Chrome

**02-325** 4-Piston Rear, Black

**NOTE:** For 11.5" applications, add a 11.8" diameter rotor in order to use 11.8" calipers

**BRAKE PADS FOR ARLEN NESS BRAKE CALIPERS**

- ▶ DP Brakes brake pads are designed with sintered metal compounds to give your bike high-tech performance in all conditions
- ▶ Fast break-in period so you get maximum performance faster
- ▶ DP Brakes design and materials ensure consistent hard stops and fade-free performance
- ▶ Sintered metal compounds outlast more conventional organic pads
- ▶ GG friction rated and made with DP Brakes proven sintered metal material
- ▶ Gray-colored aluminum oxide-based ceramic material on rear of backing plate keeps heat away from caliper piston and fluid in extreme conditions for fade-free performance
- ▶ Equal performance in wet or dry conditions
- ▶ Available for Arlen Ness 6-Piston Differential Bore & 4-Piston brake calipers



02-230



02-231

**BRAKE PADS**

**02-230** 6-Piston Replacement Brake Pads

**02-231** 4-Piston Replacement Brake Pads

**ABS WHEEL BEARINGS**

Eliminate ABS malfunction & warning lights when using oversized wheels on HD models equipped with ABS brake systems.

- ▶ Each bearing is designed to work only on the specific application; Stock 21", 23" or 26" front wheels
- ▶ Will work with most oversized 21", 23" and 26" front wheels
- ▶ Sold individually



ABS Bearings

	STOCK	21"	23"	26"
25MM	18-894	18-895	18-896	18-897







# FOOT CONTROLS

## SECTION CONTENT

- 53** Floorboards
- 53** Passenger Floorboards
- 56** Foot & Shift Pegs
- 59** Highway Peg Mounts
- 60** Shift Levers
- 62** Brake Arms
- 64** Shift Rods
- 65** Forward Control Extensions

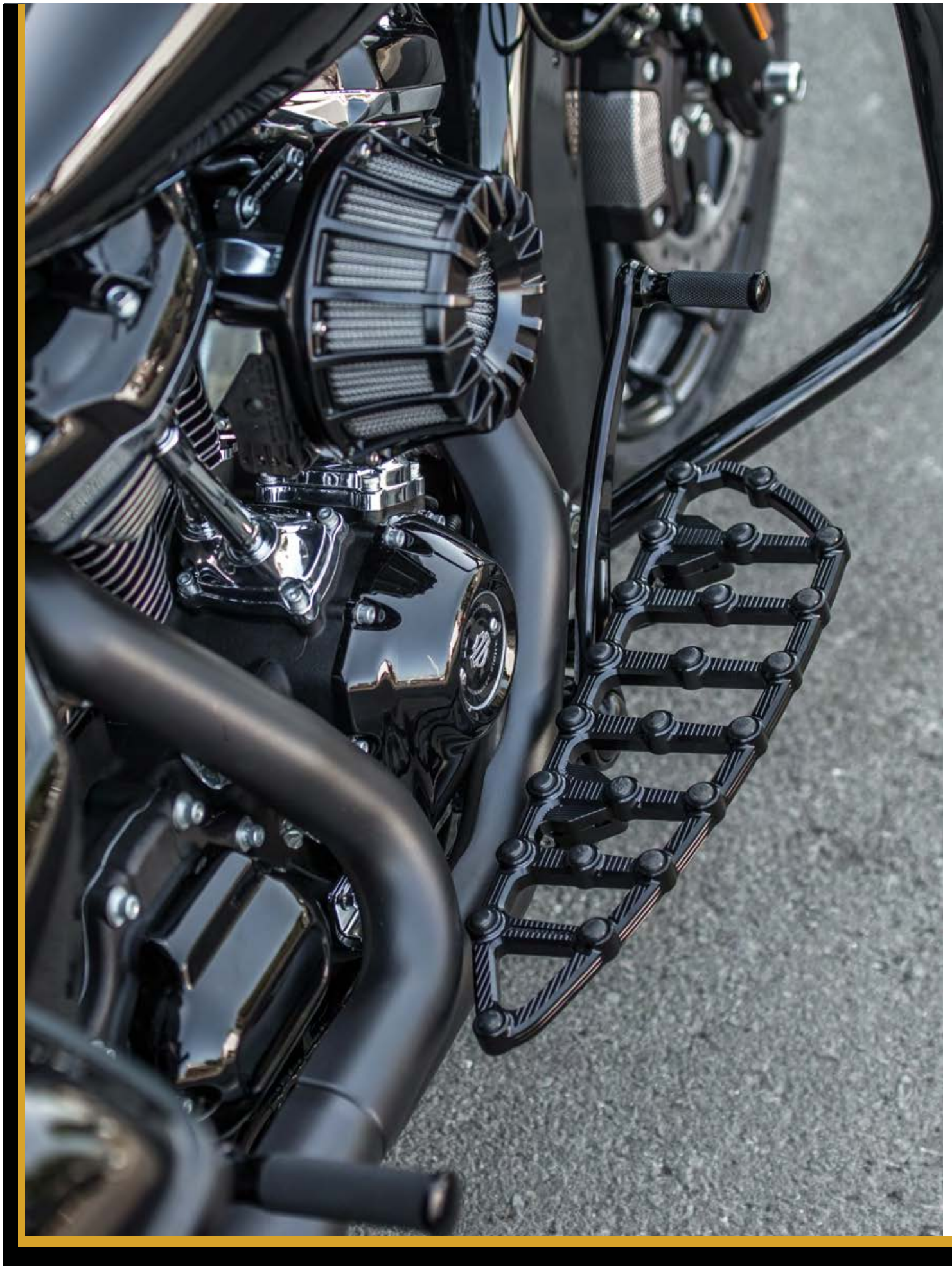



NESS-MX BLUE FLOORBOARDS



BLACK



CHROME

**NEW**

**NESS-MX FLOORBOARDS**

- ▶ MX Floorboards feature a lightweight cut through design with integrated rubber inserts for excellent foot traction
- ▶ CNC machined from billet aluminum with machined cuts on both the top and side of the floorboard for added style at every angle
- ▶ Rubber inserts offer foot traction, dampen vibration and protects the finish of the aluminum floorboard (inserts are replaceable)
- ▶ Extended length for added foot room and comfort
- ▶ Driver Dimensions: 18"L x 5.75"W x 1"T
- ▶ Passenger Dimensions: 7"L x 4"W x 1"T
- ▶ Sold in pairs



BLUE



GOLD

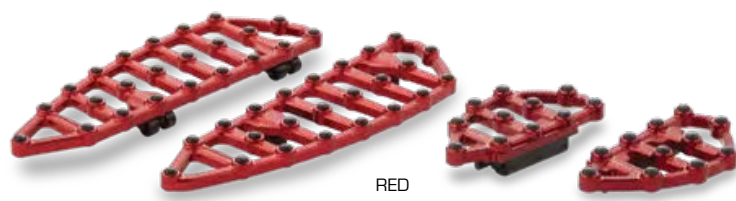

RED



ORANGE



TITANIUM

**NESS-MX DRIVER FLOORBOARDS**

- 06-891** NESS-MX Driver Boards, Black
- 06-890** NESS-MX Driver Boards, Chrome
- 06-892** NESS-MX Driver Boards, Blue
- 06-894** NESS-MX Driver Boards, Gold
- 06-893** NESS-MX Driver Boards, Red
- 06-872** NESS-MX Driver Boards, Orange
- 06-874** NESS-MX Driver Boards, Titanium

**NESS-MX PASSENGER FLOORBOARDS**

- 06-896** NESS-MX Passenger Boards, Black
- 06-895** NESS-MX Passenger Boards, Chrome
- 06-897** NESS-MX Passenger Boards, Blue
- 06-899** NESS-MX Passenger Boards, Gold
- 06-898** NESS-MX Passenger Boards, Red
- 06-877** NESS-MX Passenger Boards, Orange
- 06-876** NESS-MX Passenger Boards, Titanium



Deep Cut Black

## DEEP CUT & 10-GAUGE FLOORBOARDS

- ▶ CNC machined from forged billet aluminum
- ▶ Deep Cut design features aluminum accent cuts on both the top of the floorboard and sides for eye catching style at every angle
- ▶ 10-Gauge style features a cut through design to reduce weight and a unique look
- ▶ Rubber inserts offer foot traction and protects the finish of the board
- ▶ Extended length for comfort
- ▶ Driver floorboards: 18" L x 5.75" W x 1" T
- ▶ Passenger floorboards: 7" L x 4" W x 1" T
- ▶ Choose from chrome or black anodize finish

### DEEP CUT DRIVER FLOORBOARDS

**06-838** Deep Cut, Chrome

**06-833** Deep Cut, Black

### DEEP CUT PASSENGER BOARDS

**06-839** FLHX/Universal Peg Mount, Chrome

**06-834** FLHX/Universal Peg Mount, Black

**06-866** 94-13,15-Up FLHR/82-Up FLT, Chrome

**06-867** 94-13,15-Up FLHR/82-Up FLT, Black

### 10-GAUGE DRIVER FLOORBOARDS

**06-860** 10-Gauge, Chrome

**06-861** 10-Gauge, Black

### 10-GAUGE PASSENGER BOARDS

**06-862** 10-Gauge, Chrome

**06-863** 10-Gauge, Black

### REPLACEMENT RUBBERS

**06-846** Driver Repl. Rubbers

**06-847** Passenger Repl. Rubbers

## BEVELED FLOORBOARDS

- ▶ Forged CNC billet aluminum with knurled rubber for custom style with excellent foot traction
- ▶ Beveled style features deep sculpted CNC machined pockets around the perimeter of the floorboard, finished off with a beveled machined edge
- ▶ Knurled rubber offers foot traction in any condition
- ▶ 3 mounting points for up to 3" of adjustability (front to rear)
- ▶ Matching foot pegs available
- ▶ Driver floorboard dimensions: 13.8" L x 5.0" W
- ▶ Choose from chrome or black anodize finish

### BEVELED DRIVER FLOORBOARDS

**15-409** Beveled, Chrome

**15-410** Beveled, Black



DEEP CUT



10-GAUGE



Beveled Floorboards

NEW



NESS-MX BLACK FOOTPEGS

**NESS-MX FOOTPEGS**

- ▶ Features a lightweight cut through design with integrated rubber inserts for excellent foot traction
- ▶ CNC machined from billet aluminum
- ▶ Detailed machine cuts on both top and side of footpeg for style at every angle
- ▶ Stainless steel slider protects the billet footpeg during aggressive riding
- ▶ Splined mounting area allows rider to adjust peg to their desired riding angle
- ▶ Choose the correct forged splined footpeg mount for your application (sold separately)
- ▶ Available in black anodize, chrome, red, blue, titanium, gold, and orange finish

**NOTE: MUST CHOOSE CORRECT SPLINED MOUNT, MX PEGS DO NOT INCLUDE MOUNT**

**NESS-MX FOOTPEGS**

- 07-914 NESS-MX Footpegs, Chrome
- 07-904 NESS-MX Footpegs, Black
- 07-903 NESS-MX Footpegs, Blue
- 07-935 NESS-MX Footpegs, Gold
- 07-946 NESS-MX Footpegs, Red
- 07-969 NESS-MX Footpegs, Orange
- 07-959 NESS-MX Footpegs, Titanium



BLACK

CHROME



BLUE

GOLD



RED

ORANGE



TITANIUM

**SPLINED FOOTPEG MOUNTS**

- ▶ Adjustable footpeg mounts
- ▶ Forged from aluminum then CNC machined
- ▶ Splined design allows for a wide range of adjustability
- ▶ Includes mounting hardware with pre-applied Threadlocker
- ▶ Black anodize finish
- ▶ Available for: Standard male mount, 18-Up Softail® Driver and 18-Up Softail® Passenger (sold in pairs)
- ▶ Clevis measurements: 1/2" Wide x 7/8" tall, 3/8" hole

- 07-990 Standard Male Mount
- 07-991 18-Up Softail®, Driver
- 07-992 18-Up Softail®, Passenger

**NOTE: 18-Up Softail® fitment footpegs**  
**DRIVER:** 18-Up FXBRS/FXFBS/FXDR/FXDRS/FLSB/FXBR/FXFB/FXLR/FXBB  
**PASSENGER:** 18-Up FXBRS/FLDE/FXFB/FLFB/FLHCS/FXLR/FLSB/FXBR/FX-FBS/FLFBS/FXDRS



Splined Peg Mounts



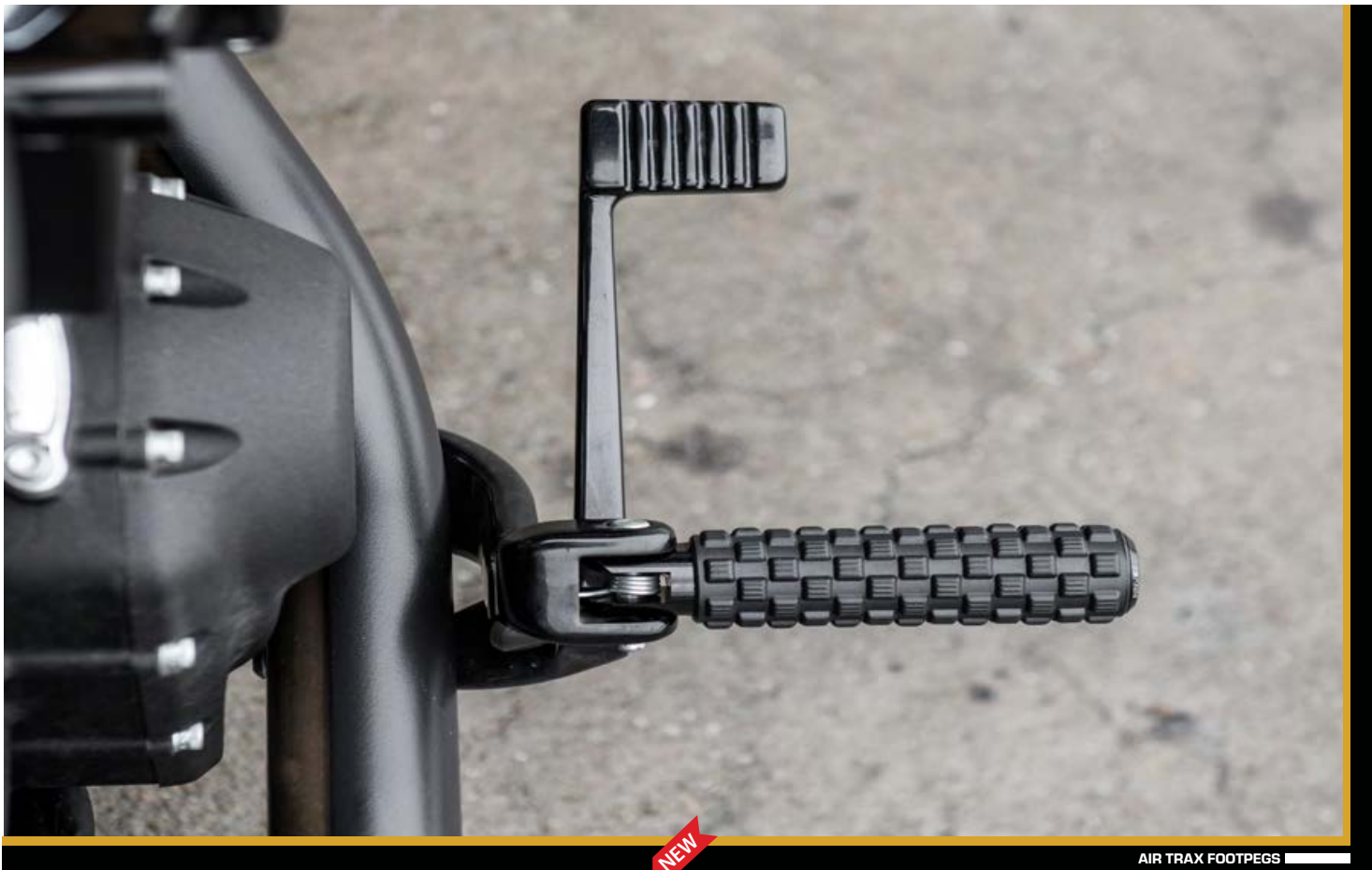

AIR TRAX FOOTPEGS

### AIR TRAX FOOT & SHIFT PEGS

- ▶ Aggressive yet comfortable rubber design
- ▶ Repeating pattern rubber offers excellent foot traction & vibration reduction,
- ▶ 1" longer than stock for more foot room
- ▶ CNC machined billet end cap with laser engraved logo
- ▶ Forged inner structure offers maximum strength
- ▶ Available in standard male mount and 18-Up Softail®
- ▶ Choose from black, chrome or brass end caps
- ▶ Footpegs are sold in pairs, shift pegs are sold individually
- ▶ [Matching grips can be found on page 72](#)



CHROME

BLACK



BRASS

#### STANDARD MALE MOUNT

	FOOTPEGS	SHIFT PEGS
Chrome	07-962	07-963
Black	07-960	07-961
Brass	07-964	07-965

**NOTE:** Shift pegs will fit both standard male mount & 18-Up Softail® models

#### 18-Up SOFTAIL®

	DRIVER	PASSENGER
Chrome	07-957	07-967
Black	07-956	07-966
Brass	07-958	07-968

**NOTE:** 18-Up Softail® fitment footpegs

**DRIVER:** 18-Up FXBRS/FXFBS/FXDR/FXDORS/FLSB/FXBR/FXFB/FXLR/FXBB

**PASSENGER:** 18-Up FXBRS/FLDE/FXFB/FLFB/FLHCS/FXLR/FLSB/FXBR/FXFBS/FLFBS/FXDORS



KNURLED FOOTPEGS

**KNURLED FOOT & SHIFT PEGS**

- ▶ Knurled rubber design features clean style with high traction rubber for excellent foot grip in all riding scenarios
- ▶ CNC machined billet end cap w/laser engraved logo
- ▶ Footpegs are 1" longer than stock for enhanced comfort & foot room
- ▶ Forged inner structure offers maximum strength
- ▶ 18-Up Softail® applications feature a forged aluminum internal structure for a steel-like structure strength without the weight
- ▶ Footpegs are sold in pairs, shift pegs are sold individually
- ▶ Matching grips can be found on page 73

**STANDARD MALE MOUNT**

	FOOTPEGS	SHIFT PEGS*
Blue	07-937	07-947
Gold	07-939	07-949
Red	07-938	07-948
Orange	07-902	07-912
Titanium	07-905	07-915
Chrome	07-924	07-926
Black	07-925	07-927
Dual Ring	07-934	07-936
Brass	07-932	07-933

NOTE: Shift pegs will fit both standard male mount & 18-Up Softail® models

**18-Up SOFTAIL®**

	DRIVER	PASSENGER
Blue	07-950	07-951
Gold	07-952	07-953
Red	07-954	07-955
Chrome	07-940	07-941
Black	07-942	07-943
Brass	07-944	07-945

NOTE: 18-Up Softail® fitment footpegs

DRIVER: 18-Up FXBRS/FXFBS/FXDR/FXDRS/FLSB/FXBR/FXFB/FXLR/FXBB

PASSENGER: 18-Up FXBRS/FLDE/FXFB/FLFB/FLHCS/FXLR/FLSB/FXBR/FXFBS/FLFBS/FXDRS





10-GAUGE FOOTPEGS



**DEEP CUT & 10-GAUGE FOOT AND SHIFT PEGS**

- ▶ Deep Cut and 10-Gauge pegs are CNC machined from billet aluminum
- ▶ 10-Gauge pegs feature a lightweight aggressive design that adds style while reducing weight
- ▶ Deep Cut pegs feature a conical profile with smooth accent cuts for eye-catching style at every angle
- ▶ Matching grips, boards and more available
- ▶ Choose from chrome or black finish
- ▶ Footpegs are sold in pairs, shift pegs are sold individually
- ▶ Matching grips can be found on page 75

10-GAUGE	CHROME	BLACK
FOOTPEGS	06-104	06-114

SHIFT/ BRAKE PEGS	06-107	06-117
----------------------	--------	--------

DEEP CUT	CHROME	BLACK
FOOTPEGS	06-470	06-472

SHIFT/ BRAKE PEGS	06-471	06-473
----------------------	--------	--------

**FOOT PEG FITMENT:** Will fit all HD models except: 13-17 FXSB/SE, 11-13 FXS, 08-11 FXCW/C, 13-17 XL1200V/XL1200X/ XL1200C/ XL1200CX, 18-Up Softail® models



DEEP CUT FOOTPEGS

**FUSION SERIES FOOT & SHIFT PEGS**

- ▶ The Fusion of high traction rubber and sculpted billet aluminum
- ▶ Foot & Shift pegs are machined from CNC billet aluminum then wrapped in knurled rubber for excellent foot grip in all riding conditions
- ▶ Choose from Smoothie, Deep Cut or Beveled styles
- ▶ Footpegs are sold in pairs, shift pegs are sold individually
- ▶ Matching grips can be found on page 74

SMOOTHIE	CHROME	BLACK
FOOTPEGS	07-920	07-921
SHIFT PEGS	07-922	07-923

DEEP CUT	CHROME	BLACK
FOOTPEGS	07-908	07-909
SHIFT PEGS	07-918	07-919

BEVELED	CHROME	BLACK
FOOTPEGS	07-928	07-929
SHIFT PEGS	07-930	07-931

**FOOTPEG FITMENT:** Will fit all HD models except: 13-17 FXSB/SE, 11-13 FXS, 08-11 FXCW/C, 13-17 XL1200V/XL1200X/ XL1200C / XL1200CX, 18-Up Softail® models



SMOOTHIE

DEEP CUT

BEVELED

**1-1/4" HIGHWAY PEG MOUNT FOR CRASH BARS**

- ▶ Add any style male mount footpeg to your motorcycle's crash bars for use as highway pegs to stretch out while on the road
- ▶ Constructed from die-cast aluminum
- ▶ Chrome & black finish
- ▶ Sold in pairs

07-190	1-1/4" peg clamp mount, Chrome
07-195	1-1/4" peg clamp mount, Black



HIGHWAY PEG MOUNT



10-GAUGE HEEL/TOE



### DEEP CUT SOLO SHIFTER

- ▶ CNC machined from 6061-T6 billet aluminum
- ▶ Adjustable, each solo shifter is splined at the mounting point to allow the rider to adjust the shift arms angle to their preference
- ▶ 1" longer than stock shift arms
- ▶ Solo shift design allow riders to have more foot room on the floorboard
- ▶ Offered in our Deep Cut style
- ▶ Matching Deep Cut billet shift peg is included in each kit
- ▶ Fitment: 99-Up FLT Touring, 99-17 FXOWG  
00-17 FLS/FXS/FLST/FXST

### SOLO SHIFTER

- |               |                             |
|---------------|-----------------------------|
| <b>19-756</b> | Deep Cut Solo Shift, Chrome |
| <b>19-757</b> | Deep Cut Solo Shift, Black  |



Deep Cut Solo Shift



### DEEP CUT INNER SHIFT LEVER

- ▶ The finishing touch for your foot control section
- ▶ CNC machined from 6061-T6 billet aluminum
- ▶ Replaces stock inner shift lever and will work with stock or any after-market shift rod
- ▶ Available for: 99-Up FLT Touring

### INNER SHIFT LEVER

- |               |                              |
|---------------|------------------------------|
| <b>19-758</b> | Deep Cut Inner Shift, Chrome |
| <b>19-759</b> | Deep Cut Inner Shift, Black  |



Deep Cut Inner Shift

**DEEP CUT HEEL / TOE SHIFT**

- ▶ Classic Deep Cut styling
- ▶ CNC machined from billet aluminum
- ▶ 1" longer than factory shifters to allow for more foot room
- ▶ Each Deep Cut heel/toe shift kit includes Deep Cut style heel shift arm, toe shift arm, Deep Cut billet shift pegs, and chrome hardware
- ▶ Fitment: 82-Up FLT, 00-17 FLST  
99-Up FLT Touring



**HEEL / TOE SHIFTER**

**19-791** Deep Cut, Heel/Toe, Chrome

**19-792** Deep Cut, Heel/Toe, Black

**NOTE:** Standard length Heel/Toe shift will not work on 14-Up FLT models with liquid cooled fairing lowers



Deep Cut Heel/Toe

**10-GAUGE HEEL / TOE SHIFT**

- ▶ Aggressive lightweight design
- ▶ CNC machined from billet aluminum
- ▶ 1" longer than factory shifters to allow for more foot room
- ▶ Each 10-Gauge heel/toe shift kit includes toe shift arm, heel shift arm, 10-Gauge billet shift pegs, and chrome hardware
- ▶ Fitment: 82-Up FLT, 00-17 FLST  
99-Up FLT Touring



**HEEL / TOE SHIFT**

**40-106** 10-Gauge, Heel/Toe, Chrome

**40-107** 10-Gauge, Heel/Toe, Black

**NOTE:** Standard length Heel/Toe shift will not work on 14-Up FLT models with liquid cooled fairing lowers



10-Gauge Heel/Toe

**RADIUS HEEL / TOE SHIFT**

- ▶ Clean universal design accepts any factory or aftermarket shift peg allowing you to keep your bike's style consistent
- ▶ CNC machined from billet aluminum
- ▶ 1" longer than factory shifters to allow for more foot room
- ▶ Each Radius heel/toe shift kit includes heel shift arm, toe shift arm, and chrome hardware
- ▶ Fitment: 82-Up FLT, 00-17 FLST  
99-Up FLT Touring/00-17FLST



**RADIUS HEEL / TOE SHIFT**

**19-790** Radius Heel/Toe, Chrome

**19-761** Radius Heel/Toe, Black

**NOTE:** Standard length Heel/Toe shift will not work on 14-Up FLT models with liquid cooled fairing lowers



Radius Heel/Toe



RADIUS BRAKE ARM



### BRAKE ARM KITS

- ▶ CNC machined from billet aluminum
- ▶ Available in Deep Cut, Radius and 10-Gauge styles
- ▶ Deep Cut and 10-Gauge styles include matching billet shift/brake peg
- ▶ Radius style does not include shift peg, allowing you to choose any aftermarket or factory footpeg you desire
- ▶ Length is 1" longer than factory brake arm

#### DEEP CUT BRAKE ARM

19-773	97-07 FLT, Deep Cut, Chrome
19-768	97-07 FLT, Deep Cut, Black
19-774	08-13 FLT, Deep Cut, Chrome
19-778	08-13 FLT, Deep Cut, Black
19-763	14-Up FLT, Deep Cut, Chrome
19-764	14-Up FLT, Deep Cut, Black
19-752	00-13 FXST, Deep Cut, Chrome
19-753	00-13 FXST, Deep Cut, Black

#### 10-GAUGE BRAKE ARM

40-114	97-07 FLT, 10-Gauge, Chrome
40-115	97-07 FLT, 10-Gauge, Black
40-134	08-13 FLT, 10-Gauge, Chrome
40-120	14-Up FLT, 10-Gauge, Chrome
40-121	14-Up FLT, 10-Gauge, Black
40-122	00-17 FLST, 10-Gauge, Chrome
40-123	00-17 FLST, 10-Gauge, Black



Deep Cut Brake Arm



10-Gauge Brake Arm



RADIUS BRAKE ARM

**RADIUS BRAKE ARM**

19-772	97-07 FLT, Radius, Chrome
19-739	97-07 FLT, Radius, Black
19-775	08-13 FLT, Radius, Chrome
19-746	08-13 FLT, Radius, Black
19-766	14-Up FLT, Radius, Chrome
19-760	14-Up FLT, Radius, Black
19-767	00-17 FLST, Radius, Chrome
19-769	00-17 FLST, Radius, Black



19-739



Radius Brake Arm

**DEEP CUT FOOT CONTROL FAMILY PACK**

- ▶ Save time and money dressing up your Touring model
- ▶ Each Deep Cut kit includes: Inner Shifter Lever, Brake Arm, Heel/Toe Shifter, and a Deep Cut Round Shifter Rod
- ▶ All accessories in the kit are machined from billet aluminum
- ▶ Available in chrome or black anodize finish
- ▶ Fits 14-Up FLT models

91-111 Deep Cut Foot Control Pack, Chrome

91-110 Deep Cut Foot Control Pack, Black



Deep Cut Family Kit





RETRO SHIFT ROD



DEEP CUT ROUND



DEEP CUT FLAT



BEVELED



10-GAUGE



RETRO

## SHIFT RODS

- ▶ A step above the traditional shift rod
- ▶ Features specially designed spherical bearings hydraulically pressed in for a clean look, eliminating the need for heim joints
- ▶ CNC machined from 6061-T6 billet aluminum
- ▶ Available in a black anodize or chrome finish
- ▶ Designed to fit all HD® models except FXD, FXR, and XL models with mid-controls

### DEEP CUT ROUND

19-931 Deep Cut, Black

19-930 Deep Cut, Chrome

### DEEP CUT FLAT

19-913 Deep Cut Flat, Black

19-912 Deep Cut Flat, Chrome

### BEVELED

19-933 Beveled, Black

19-932 Beveled, Chrome

### 10-GAUGE

19-941 10-Gauge, Black

19-940 10-Gauge, Chrome

### RETRO

19-938 Retro, Chrome

19-939 Retro, Black

**3" FORWARD CONTROL EXTENSIONS FOR SOFTAIL® MODELS**

- ▶ Relocates factory foot controls 3" forward to increase rider legroom
- ▶ Adapter plates are CNC machined from billet aluminum and black anodized for a clean look
- ▶ Extended steel shift rod designed to work with factory controls
- ▶ Stainless steel braided brake lines
- ▶ Each 3" extension kit includes two billet aluminum adapter plates, extended rear brake line, extended shift rod, kickstand spring pin, bracket for 04-Up models and all necessary hardware
- ▶ Sold in pairs

**EXTENSION KITS**

**07-610** 00-06 Softail®

**07-611** 07-17 Softail®

**07-616** 11-17 Softail® w/ ABS

**ACCESSORIES**

**07-612** Replacement brake line 00-06 Softail®

**07-613** Replacement brake line 07-17 Softail®

**07-617** Replacement brake line for 11-17 Softail® w/ ABS



Softail® 3" Forward Control Extension Kit







# HAND CONTROLS

## SECTION CONTENT

- 69** Risers
- 70** Handlebars
- 71** Adjustable Handlebar Clamps
- 71** Handlebar Dampening Kits
- 71** Riser Extensions
- 72** Grips
- 75** Hand Levers
- 76** Mirrors





10" CHROME METHOD RISER

**METHOD RISERS**

- ▶ CNC machined from forged billet aluminum for reduced weight and maximum strength
- ▶ Clean yet aggressive styling featuring machined windows and sculptured pockets
- ▶ CNC machined recess on bottom of riser eliminates the need for top cup washer on handlebar dampener kit for a cleaner look and more positive feel
- ▶ 1" clamping area
- ▶ Additional billet spacers and hardware is included with each riser kit to give the option to accept factory gauge mounts with 4.25" mounting hole
- ▶ Available in 10", 6" or 2.5" heights

**10" RISERS**

- 08-060 10" Method Riser, Black
- 08-061 10" Method Riser, Chrome

**6" RISERS**

- 08-062 6" Method Riser, Black
- 08-063 6" Method Riser, Chrome

**2.5" RISERS**

- 08-064 2.5" Method Riser, Black
- 08-065 2.5" Method Riser, Chrome



08-060



10" RISER

6" RISER

2.5" RISER



Bagger Apes

### MODULAR ADJUSTABLE HANDLEBARS, 13" BAGGER APES

- ▶ Adjustable multi-piece handlebar design
- ▶ 1-1/4" handlebars that feature billet aluminum junction clamps which allows the rider to adjust the bars to their preferred riding position
- ▶ Billet junction clamps feature 5 heavy duty bolts to lock down the bar
- ▶ Accepts factory length cables and brake lines
- ▶ Knurled 1" center clamping area (3-1/2" wide)
- ▶ Accepts 1" controls and grips
- ▶ Drilled & slotted for internal wiring for both cable & fly-by-wire (FBW) throttle
- ▶ Fitment: 08-Up Street Glide™ FLHX/ Ultra FLHT models

### 13" MODULAR HANDLEBAR APES

- 08-970** 13" Bagger Apes for FLHT, FLHX, Chrome
- 08-960** 13" Bagger Apes for FLHT, FLHX Black



Bagger Apes, 13"

### MODULAR ADJUSTABLE HANDLEBARS, 10" & 11" MINI APES

- ▶ Adjustable multi-piece handlebar design
- ▶ 1-1/4" handlebars that feature billet aluminum junction clamps which allows the rider to adjust the bars to their preferred riding position
- ▶ Billet junction clamps feature 5 heavy duty bolts to lock down the bar
- ▶ 13" height accepts factory length cables and brake lines
- ▶ Knurled 1" center clamping area (3-1/2" wide)
- ▶ Accepts 1" controls and grips
- ▶ Drilled and slotted for internal wiring for both cable & fly-by-wire (FBW) throttle
- ▶ 10" Fitment: Road Glide® FLTR/Road King FLHR/Dyna® FXD/Softail® FXST & FLST/Sportster XL models
- ▶ 11" Fitment: 15-Up Road Glide FLTR

### CHROME

- 08-972** 10" Mini Apes for ALL Dyna®, XL & Softail® FLTR
- 08-974** 11" Modular Mini Apes for 15-Up Road Glide®

### BLACK

- 08-962** 10" Mini Apes for ALL Dyna®, XL & Softail® FLTR
- 08-964** 11" Modular Mini Apes for 15-Up Road Glide®

**NOTE:** 10" will not fit FXSTS/FLSTS/FXS, 15-Up FLTR or Breakout



Mini Apes



Mini Apes, 10" or 11"

### MODULAR HANDLEBAR MEASUREMENTS

		CENTER WIDTH	WIDTH	RISE	PULLBACK	DIAMETER
<b>08-970/ 08-960</b>	13" Bagger Apes for FLHT, FLHX	15"	36"	13"	8"	1-1/4"
<b>08-972/ 08-962</b>	10" Mini Apes for ALL Dyna®, XL & Softail® FLTR (except FXSTS, FLSTS, FXS, 15-Up FLTR or Breakout models)	10"	35"	10"	5"	1-1/4"
<b>08-974/ 08-964</b>	11" Modular Mini Apes for 15-Up Road Glide®	10"	36"	11"	8"	1-1/4"



BLACK CLAMPS

### ADJUSTABLE HANDLEBAR CLAMPS

- ▶ Innovative billet clamps convert your existing handlebars into an adjustable handlebar for added comfort & style
- ▶ Allows rider to adjust the bar to their specific riding position
- ▶ Each clamp is 4" long and features an internal center stop to properly pinch 2" of each side of the bar for a secure hold
- ▶ Available for 1" & 1-1/4" handlebars
- ▶ Chrome or black anodize finish
- ▶ Sold in pairs

#### CHROME

**08-051** Fits 1" handlebars

**08-053** Fits 1-1/4" handlebars

#### BLACK

**08-050** Fits 1" handlebars

**08-052** Fits 1-1/4" handlebars

### HANDLEBAR DAMPENING KITS

- ▶ A must when changing to aftermarket handlebars or risers
- ▶ Proprietary polyurethane bushings add a more positive and rigid feel to the handlebar
- ▶ Eliminates flex and isolates vibration
- ▶ Heavy duty cup washers will not bend or distort like factory units
- ▶ Each kit includes polyurethane bushings, inner steel sleeves, and heavy duty chrome cup washers

**08-029** Dampening kit for 84-Up FLT

**08-025** Dampening kit for 18-Up Softail®

**08-005** Dampening kit for 73-17 Softail®/Dyna®/FXR & 73-18 XL

**NOTE:** Will not fit 04-10 XL, Springer models

### 1" HANDLEBAR EXTENSION SPACERS

- ▶ Simply raises your risers or handlebars by 1"
- ▶ Replaces your existing handlebar bushing top cup washer for a secure fit and clean look
- ▶ Great for T-Bar handlebars or any setup needing an extra 1" of height
- ▶ Lathe cut billet steel
- ▶ Chrome finish
- ▶ Sold in pairs

**08-010** 1" Handlebar Extension Spacers



CHROME



BLACK



Polyurethane Handlebar Dampening Kit



Extension Spacers





**NEW**

**BLACK AIR TRAX GRIPS**



Chrome Air Trax Grips

### AIR TRAX GRIPS

- ▶ Grips feature an aggressive but comfortable rubber design that offers excellent hand traction while reducing vibration
- ▶ Grip end cap is CNC machined from billet aluminum or brass
- ▶ Available in black anodize, brass or chrome finish
- ▶ Laser engraved Arlen Ness Logo
- ▶ Matching foot and shift pegs available separately
- ▶ Sold in pairs ([matching footpegs can be found on page 56](#))

	CABLE STYLE	FLY-BY-WIRE
Air Trax, Chrome	07-351	07-353
Air Trax, Black	07-350	07-352
Air Trax, Brass	07-354	07-355



CHROME

BLACK

BRASS



BLACK KNURLED GRIPS

**KNURLED GRIPS**

- ▶ Features knurled rubber for excellent hand traction and a billet aluminum end cap for a clean look
- ▶ Available for cable and fly-by-wire applications
- ▶ Choose from chrome, black, brass, red, blue, gold, orange, titanium or dual ring end caps
- ▶ Laser engraved Arlen Ness Logo
- ▶ Sold in pairs (matching footpegs can be found on page 57)

	CABLE STYLE	FLY-BY-WIRE
Knurled, Chrome	07-324	07-326
Knurled, Black	07-325	07-327
Knurled, Brass	07-332	07-334
Knurled, Dual Ring	07-308	07-310
Knurled, Blue	07-335	07-345
Knurled, Gold	07-337	07-347
Knurled, Red	07-336	07-346
Knurled, Orange	07-304	07-306
Knurled, Titanium	07-338	07-348



Black Knurled Grips





FUSION BEVELED BLACK GRIPS

### FUSION SERIES GRIPS

- ▶ The Fusion of CNC billet aluminum and high traction hand grip rubber for added style and control
- ▶ Features knurled rubber with billet end cap and collar
- ▶ Available for cable or fly-by-wire applications
- ▶ Choose from chrome or black anodize finish
- ▶ Sold in pairs ([matching footpegs can be found on page 59](#))

#### CABLE STYLE / FLY-BY-WIRE

	CABLE STYLE	FLY-BY-WIRE
<b>Deep Cut, Chrome</b>	07-316	07-318
<b>Deep Cut, Black</b>	07-317	07-319
<b>Smooth, Chrome</b>	07-320	07-322
<b>Smooth, Black</b>	07-321	07-323
<b>Beveled, Chrome</b>	07-330	07-328
<b>Beveled, Black</b>	07-331	07-329





DEEP CUT

### DEEP CUT & 10-GAUGE COMFORT SERIES GRIPS

- ▶ Billet grip designs that have a slightly larger diameter than factory which helps with hand fatigue and provides increased comfort
- ▶ Deep Cut style features a conical style grip body with innovative rubber inserts that have a soft air cushion feel to help dampen vibration
- ▶ 10-Gauge style features accent cuts running the length of the grip body with linear style rubber providing comfort for the long haul
- ▶ Available for cable and fly-by-wire applications
- ▶ Choose from chrome or black finish
- ▶ Sold in pairs (matching footpegs can be found on page 58)



10-GAUGE

DEEP CUT

### CABLE STYLE / FLY-BY-WIRE

<b>10-Gauge, Chrome</b>	07-114	07-119
<b>10-Gauge, Black</b>	07-124	07-129
<b>Deep Cut, Chrome</b>	07-050	07-052
<b>Deep Cut, Black</b>	07-051	07-053

### FORGED BILLET HAND LEVERS

- ▶ Each hand lever is forged from billet aluminum and then CNC machined to a perfect finish
- ▶ These levers add style to factory hand controls while keeping factory function
- ▶ Available in chrome or black anodize finish
- ▶ Designed to fit 08-Up FLT models, choose proper application
- ▶ Sold in pairs

### CHROME

<b>08-901</b>	Cable Style, Touring 08-13 FL/14-16 FLHR/FLHRC
<b>08-908</b>	Hydraulic Style, Touring 17-Up FLT
<b>08-906</b>	Hydraulic Style, Touring 14-16 FL (except FLHR/FLHRC)

### BLACK

<b>08-900</b>	Cable Style, Touring 08-13 FL/14-16 FLHR/FLHRC
<b>08-907</b>	Hydraulic Style, Touring 17-Up FLT
<b>08-905</b>	Hydraulic Style, Touring 14-16 FL (except FLHR/FLHRC)



Deep Cut Chrome



Hand Levers



BLACK MINI STOCKER MIRROR

### MINI STOCKER MIRRORS

- ▶ Clean smooth flowing design
- ▶ Mirror head and stem are forged from billet aluminum
- ▶ Heavy duty stainless steel internal pivot hardware
- ▶ Compact size is designed to blend in and flow with the lines of the motorcycle but still large enough for great rear vision
- ▶ Mounting hardware for standard and metric applications included
- ▶ Available in black, chrome, red, blue, gold or titanium finish
- ▶ Sold individually



BLACK

CHROME

RED

BLUE

GOLD

TITANIUM

	LEFT	RIGHT
Mini Stocker Black	13-156	13-158
Mini Stocker, Chrome	13-157	13-159
Mini Stocker, Red	13-152	13-155
Mini Stocker, Blue	13-150	13-153
Mini Stocker, Gold	13-151	13-154
Mini Stocker, Titanium	13-168	13-169

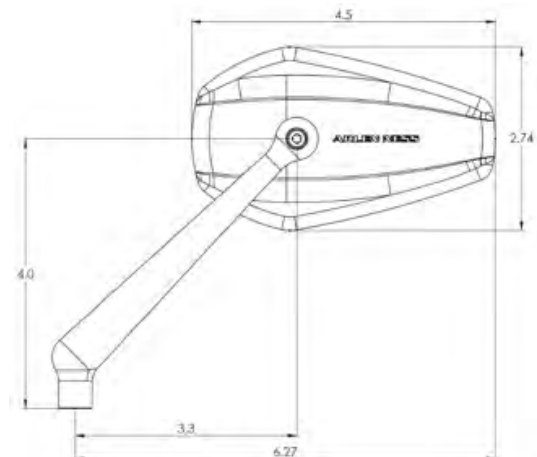



BLACK FORGED OVAL MIRROR

**FORGED OVAL MIRRORS**

- ▶ Forged Oval design features clean universal styling
- ▶ Mirror head & stem forged from billet aluminum and then CNC machined
- ▶ Heavy duty Stainless Steel internal pivot hardware
- ▶ Laser engraved Arlen Ness Logo
- ▶ Sold individually

	LEFT	RIGHT
Forged Oval Mirror, Black	13-170	13-172
Forged Oval Mirror, Chrome	13-171	13-173
Forged Oval Mirror, Red	13-176	13-179
Forged Oval Mirror, Blue	13-174	13-177
Forged Oval Mirror, Orange	13-185	13-187
Forged Oval Mirror, Gold	13-175	13-178

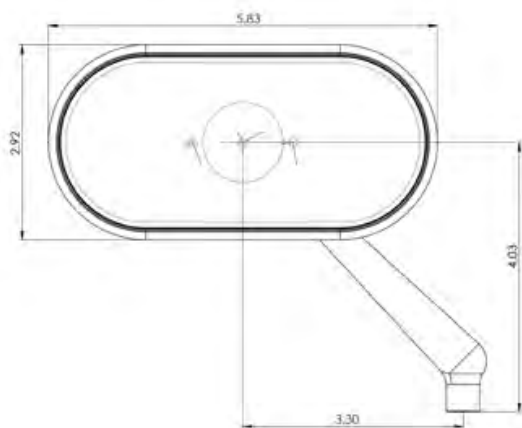

BLACK



CHROME



RED



BLUE



ORANGE



GOLD



DIAMOND FORGED BLACK BILLET MIRROR

### DIAMOND FORGED BILLET MIRRORS

- ▶ Mirror head and stem both CNC machined from forged aluminum
- ▶ Modern diamond style design, DOT sized
- ▶ Heavy duty stainless steel internal pivot hardware
- ▶ Choose from chrome or black anodize finish
- ▶ Sold individually



DIAMOND BLACK



DIAMOND CHROME



BEVELED CATEYE



SMOOTHIE CATEYE

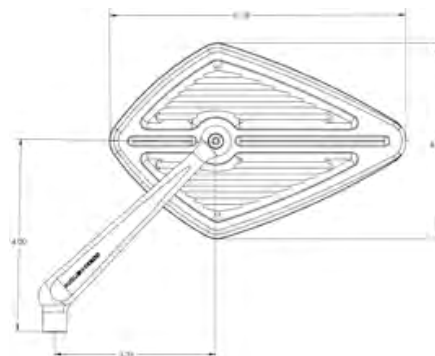

### CATEYE FORGED BILLET MIRRORS

- ▶ Each mirror and stem is forged from billet aluminum and then CNC machined to perfection
- ▶ Convex glass for a wide field of vision
- ▶ Forged mirrors feature a stainless steel pivot that is hydraulically pressed into each mirror stem and mounts to a triangulated spring plate in the mirror head that is guaranteed to never loosen or vibrate out of adjustment
- ▶ Available in chrome or black anodize finish
- ▶ Each mirror includes mounting hardware for both Harley Davidson® and metric applications
- ▶ Sold individually

	LEFT	RIGHT
Smoothie Cateye, Chrome	13-136	13-138
Smoothie Cateye, Black	13-135	13-137
Beveled Cateye, Chrome	13-131	13-133
Beveled Cateye, Black	13-130	13-132



10-GAUGE CHROME MIRROR

**CAGED SERIES FORGED BILLET MIRRORS**

- ▶ Lightweight forged multi-piece design mirrors
- ▶ Oval Mirror heads measure 5.45" wide x 2.5" tall
- ▶ Forged mirror stem & head
- ▶ Stainless Steel machined pivot hardware
- ▶ Available in chrome or black anodize finish
- ▶ Patent Pending
- ▶ Sold individually

	LEFT	RIGHT
10-Gauge, Chrome	13-161	13-163
10-Gauge, Black	13-160	13-162
Deep Cut, Chrome	13-165	13-167
Deep Cut, Black	13-164	13-166
Side Kick, Chrome	510-001	510-003
Side Kick, Black	510-000	510-002

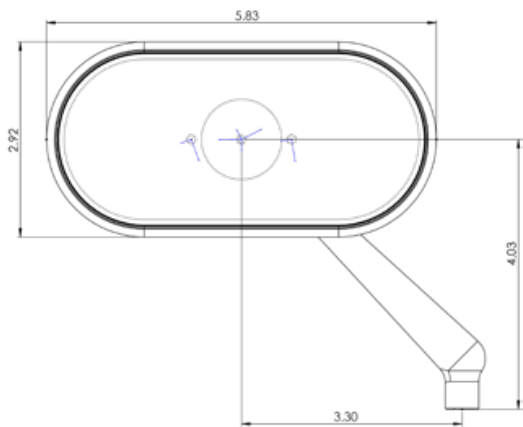

SIDEKICK



DEEP CUT



10-GAUGE



## MICRO MIRRORS

- ▶ Clean and compact designs that add style to your motorcycle
- ▶ Convex glass for a wide field of vision
- ▶ Adjustable swivel mount mirror heads allows mirror to be adjusted to riders preferred position
- ▶ Available in chrome plated or black Powder coat finish
- ▶ Each mirror includes mounting hardware for both Harley Davidson® and metric applications
- ▶ Sold individually

### CHROME

	LEFT	RIGHT
Flamed	13-070	13-071
Scoop	13-060	13-061
Mini-Oval	13-406	13-407
Four Point	13-416	13-417
RAD II	13-410	13-411

### BLACK

	LEFT	RIGHT
Flamed	13-087	13-088
Scoop	13-028	13-029
Mini-Oval	13-412	13-413
Four Point	13-418	13-419
Upswept	13-404	13-405
RAD II	13-400	13-401

**NOTE:** US Patent #s:  
Four Point; D522,942S  
Rad II; D570,755S



RAD II



FOUR POINT



SCOOP



MINI OVAL



FLAMED



UPSWEPT

**RAD III MIRRORS**

- ▶ RAD III mirrors were designed to offer clean custom styling without sacrificing field of vision or safety
- ▶ Features Convex glass & adjustable swivel mount mirror head
- ▶ Mirror stems are available in steel or sculpted cast stem
- ▶ Available in chrome or black Powder coat finish
- ▶ Each mirror includes mounting hardware
- ▶ D.O.T. approved
- ▶ Glass dimensions: 7" W x 3" H
- ▶ Sold individually

CHROME	LEFT	RIGHT
RAD III, Cast	13-090	13-091
RAD III, Steel (HD only)	13-072	13-073

BLACK	LEFT	RIGHT
RAD III, Cast	13-092	13-093
RAD III, Steel (HD only)	13-082	13-083

**ORIGINAL STYLE MIRRORS**

- ▶ Early designs offering timeless classic style for your motorcycle
- ▶ Features Convex glass & adjustable swivel mount mirror head
- ▶ Chrome plated finish
- ▶ Each mirror includes mounting hardware for both Harley Davidson® and metric applications
- ▶ Sold individually

STYLE	LEFT	RIGHT
Stealth, Long-Stem	13-058	13-058
Stealth, Short-Stem	13-053	13-053
Oval Stepped	13-044	13-044
Slingshot Grooved	13-040	13-040
Cat-Eye Softbend, Smooth	13-046	13-046
3D Cat-Eye	13-068	13-069
Teardrop	13-035	13-036

**NOTE:** Some Original Style Mirrors can be used as a left and right side mirror, all mirrors are sold individually



RAD III, CAST



RAD III, STEEL



STEALTH, LONG STEM



STEALTH, SHORT STEM



CAT-EYE SOFTBEND, SMOOTH



SLINGSHOT, GROOVED



OVAL, STEPPED



TEARDROP



3D CAT-EYE





# AIR CLEANERS & EXHAUST

## SECTION CONTENT

- 84** Big Sucker Air Cleaners
- 94** Monster Sucker Air Cleaners
- 95** Velocity 65 Air Cleaners
- 96** Inverted Air Cleaners
- 98** Method Air Cleaners
- 100** Sidekick Air Cleaners
- 102** Clear Tear Air Cleaners
- 104** Slip-On Mufflers
- 105** Exhaust Clamps
- 106** Head Pipes
- 106** Full Exhaust Systems



SMOOTH STAGE I, BLACK SYNTHETIC AIR FILTER



**BIG SUCKER™ STAGE I AIR CLEANERS,  
TWIN CAM/SPORTSTER®/EVO**

- ▶ Engineered to give your engine maximum airflow for more horsepower & torque
- ▶ One-piece aluminum backing plate features our patented hidden breather technology, each breather is o-ringed at the heads and exits at the mouth of the throttle body eliminating the need for any external hoses or hardware for efficient engine breathing
- ▶ Each backing plate contains a smooth radius air inlet to direct unobstructed airflow into the engine
- ▶ Stage I kits accept factory and/or Ness air cleaner covers for the exposed look. Kits specifically designed to accept factory air cleaner cover only [found on pg. 84]
- ▶ Performance air filters are available in standard pre-oiled cotton & synthetic filter elements. Standard performance filters are constructed from red pre-oiled cotton and are washable/reusable. Filter re-charge kits available separately
- ▶ Synthetic performance filters are constructed from black synthetic filter element that is wrapped in a stainless steel jacket. Synthetic filters are washable/re-usable, do not require oil and are water resistant which in most cases eliminates the need for a rain sock
- ▶ Backing plates available in standard, black or chrome finish
- ▶ Each Stage I kit includes one-piece aluminum backing plate, performance filter, gaskets, and necessary hardware

**BACKING PLATE FINISH / AIR FILTER TYPE**



STANDARD / RED



BLACK / RED



CHROME / SYNTHETIC



BLACK / SYNTHETIC

	08-16 FLT 16-17 Softail & FXDLS	99-17 TWIN CAM (EXC. 99-01 FI FLT & FBW MODELS)	93-99 EVO	99-01 FI FLT	88-Up XL
--	------------------------------------	---	--------------	-----------------	-------------

**STAGE I, STANDARD RED PRE-OILED FILTER [RED]\***

Standard Backing Plate	18-510	18-505	18-500	18-498	18-803
Chrome Backing Plate	18-512	18-507	18-501	18-503	18-822
Black Backing Plate	18-560	18-561	18-562	18-563	18-564

**STAGE I, SYNTHETIC FILTER [BLACK]\***

Chrome Backing Plate	50-514	50-515	50-516	50-517	50-518
Black Backing Plate	50-570	50-571	50-572	50-573	50-574

\*These air cleaners have received a California Executive Order (Executive Order D-639-8) \*14-16 FLT kits requires a Ness custom cover, factory cover will not fit



KNUCKLE STAGE I, CHROME

**M8 BACKING PLATE FEATURES**

**Patent - Pending Hidden Breather Technology**

The next generation of Big Sucker air cleaner technology. Our hidden breather system is o-ringed at the heads, passes through the machined channels inside of the backing plate, and exits inside the mouth of the throttle body through patent-pending "shooter" tubes.

**Patent - Pending Oil Catch**

New integrated oil catch ensures no engine breather oil ever ends up on your filter, restricting flow. Oil catch's bolt on design allows it to be serviced when it's time to service the air filter.



**Aluminum Design**

Aluminum backing plate features a one-piece design stacked with performance enhancing features and a new aluminum filter top plate with integrated mounting studs. The next generation design increases performance as well as reliability.

**Formed Style Features**

New outer filter lip is formed into the face of the backing plate to better secure the air filter in place while hiding the urethane filter base for a clean look leaving only air flow enhancing filter media exposed.

**BIG SUCKER™ STAGE I AIR CLEANER KIT FOR MB ENGINE**

The Big Sucker™ Stage I performance intake for Milwaukee-Eight® (M8) engines adds horsepower, torque and eliminates oil blow-by issues. Our next generation patent-pending hidden breather system is o-ringed at the heads, passes through the backing plate and exits inside the mouth of the throttle body through proprietary shooter tubes.

- ▶ Increases horsepower, torque and mileage
- ▶ Eliminates oil blow-by issues associated with performance intakes on M8 engines
- ▶ Black pre-oiled high performance filter is washable
- ▶ Patent-pending oil catch/reservoir collects any excess breather oil to keep your filter dry
- ▶ One-piece aluminum backing plate
- ▶ Aluminum filter top plate design eliminates internal mounting hardware
- ▶ Accepts Ness Stage I outer covers and M8 Softail® models w/ single bolt factory air cleaner covers

**BIG SUCKER™ FOR MB ENGINES\***

- 18-317 Stage I M8, Chrome
- 18-318 Stage I M8, Black



18-318



CHROME

BLACK

\*These air cleaners have received a California Executive Order (Executive Order D-639-8)



### BACKING PLATE FEATURES

#### Patent - Pending Hidden Breather Technology

Our hidden breather system is o-ringed at the heads, passes through the machined channels inside of the backing plate, and exists inside the mouth of the throttle body through patent-pending "shooter" tubes.

#### Patent - Pending Oil Catch

New integrated oil catch ensures no engine breather oil ever ends up on your filter, restricting airflow. Oil catch's bolt-on design allows it to be serviced when its time to service the air filter.



#### Aluminum Design

One-piece design with integrated performance features. Shaped to fit the factory FLT air cleaner cover and fit a full perimeter flow air filter design to bring in maximum airflow.

#### Aluminum Filter Top Plate

Formed aluminum top plate has integrated studs that eliminate the need for any additional mounting hardware and an air venturi that forces air into the engine.



BLACK

### BIG SUCKER™ AIR CLEANERS FOR FACTORY COVER, 17-UP FLT

The Big Sucker™ Performance Air Cleaner for Milwaukee-Eight® (M8) 17-Up Baggers is specially designed to pull in the most air possible under the factory air cleaner cover. The backing plate features a new patent-pending hidden breather system and a formed aluminum internal design resulting in more performance with no oil blow-by issues. The newly integrated patent-pending oil catch makes sure no oil ever touches the massive perimeter-flow air filter.

- ▶ Increases horsepower, torque & mileage
- ▶ Eliminates oil blow-by issues associated with performance intakes on M8 engines
- ▶ Red pre-oiled high performance filter is washable
- ▶ Patent-pending oil catch/reservoir
- ▶ Patent-pending hidden breather backing plate
- ▶ Aluminum filter top plate design eliminates internal mounting hardware and features a specially formed air venturi that directs airflow into the radius air inlet

### STAGE I BIG SUCKER™ FOR 17-Up FACTORY COVER \*

18-457	17-Up FLT, Standard backing plate
18-458	17-Up FLT, Chrome backing plate
18-459	17-Up FLT, Black backing plate

### REPLACEMENT FILTER \*

18-088	17-Up FLT, Replacement filter
--------	-------------------------------



Standard Backing Plate

Black Backing Plate

**BIG SUCKER™ AIR CLEANERS FOR FACTORY COVERS, TWIN CAM**

- ▶ Designed to increase performance while retaining the factory look
- ▶ Each kit is specially designed to have the largest air filter and air flow volume when using the factory outer air cleaner cover
- ▶ Increases horsepower, torque & mileage
- ▶ Patented hidden breather technology
- ▶ Pre-oiled red high performance filter
- ▶ One-piece aluminum backing plate
- ▶ Radius air inlet for unobstructed airflow
- ▶ Fitment: 14-16 FLT / 15-17 FLST / 08-16 FXD

14-16 FLT/  
15-17 FLST  
MODELS EXC.  
FLSTFBF

08-16  
FX/FXD  
(EXC. FXDB)

**STANDARD FILTER\***

Standard, Backing Plate	18-440	18-827
Chrome, Backing Plate	18-441	18-828
Black, Backing Plate	18-442	18-829

**NOTE:** Will not fit FLSTFBF & FXDB models. Kits designed to fit factory cover only

**REPLACEMENT FILTER\***

Replacement filter	18-082	18-041
--------------------	--------	--------



18-441



STANDARD

BLACK

**BIG SUCKER™ AIR CLEANERS FOR FACTORY COVERS, XL SPORTSTER®**

- ▶ Designed to increase performance while retaining the factory look
- ▶ Each kit is specially designed to have the largest air filter and air flow volume when using the factory outer air cleaner cover
- ▶ Increases horsepower, torque & mileage
- ▶ Patented hidden breather technology
- ▶ Pre-oiled red high performance filter
- ▶ One-piece aluminum backing plate
- ▶ Radius air inlet for unobstructed airflow
- ▶ Fitment: 18-17 XL (2-bolt oval style factory cover)  
16-Up XL 48, 72 & Iron Models (Single-bolt 8" round factory covers)

16-Up  
48/72/  
IRON XL

88-Up XL /FX  
(EXC.48/72/IRON)

**STANDARD RED PRE-OILED FILTER\***

Standard, Backing Plate	18-445	18-824
Chrome, Backing Plate	18-446	18-825
Black, Backing Plate	18-447	18-826

**NOTE:** Kits designed to fit factory cover only, will not accept custom outer covers

**REPLACEMENT FILTER\***

Replacement filter	18-099	18-040
--------------------	--------	--------



18-824



88-Up XL Sportster®

16-Up 48/72/Iron XL Sportster®

\*These air cleaners have received a California Executive Order [Executive Order D-639-8]



## BIG SUCKER™ STAGE I OPTIONS



**BEVELED STAGE I /RED**



**BEVELED STAGE I /SYNTHETIC**



**BEVELED STAGE I /MB**

- ▶ Stage I Big Sucker™ kits that include a Ness custom outer cover for an exposed custom look
- ▶ Original Big Sucker™ kits are available with red pre-oiled cotton or black stainless steel jacketed synthetic filter elements
- ▶ MB kits are available with black pre-oiled performance filter elements
- ▶ Backing plates available in black or chrome finish
- ▶ Each kit includes backing plate, performance filter, gaskets, hardware and air cleaner cover

	08-16 FLT 16-17 SOFTAIL®FXDLS	99-17 TWIN CAM (EXC. 99-01 FI FLT & FBW MODELS)	93-99 EVOLUTION	99-01 FI FLT	88-Up XL	17-Up M8
<b>STANDARD FILTER*</b>						
Smooth Black	18-325	18-326	18-327	18-328	18-329	18-306
Smooth Chrome	18-320	18-321	18-322	18-323	18-324	18-307
Slot Track, Black	18-345	18-346	18-347	18-348	18-349	18-308
Beveled, Black	18-360	18-361	18-362	18-363	18-364	18-309
Beveled, Chrome	18-365	18-366	18-367	18-368	18-369	18-314
10-Gauge, Black	18-290	18-291	18-292	18-293	18-294	18-315
10-Gauge, Chrome	18-295	18-296	18-297	18-298	18-299	18-316
Knuckle, Black	18-750	18-751	N/A	N/A	18-754	18-342
Knuckle, Chrome	18-755	18-756	N/A	N/A	18-759	18-393
Carbon Fiber	18-740	18-741	N/A	N/A	18-744	18-394
Brass	18-757	18-758	N/A	N/A	18-743	18-395
Brushed Stainless Steel	18-752	18-753	N/A	N/A	18-742	18-344
<b>SYNTHETIC FILTER</b>						
Smooth Black	50-335	50-336	50-337	50-338	50-339	N/A
Smooth Chrome	50-330	50-331	50-332	50-333	50-334	N/A
Slot Track, Black	50-835	50-836	50-837	50-838	50-839	N/A
Beveled, Black	50-840	50-841	50-842	50-843	50-844	N/A
Beveled, Chrome	50-845	50-846	50-847	50-848	50-849	N/A
10-Gauge, Black	50-290	50-291	50-292	50-293	50-294	N/A
10-Gauge, Chrome	50-295	50-296	50-297	50-298	50-299	N/A

\*These air cleaners have received a California Executive Order (Executive Order D-639-8)



SMOOTH



BEVELED



10-GAUGE



KNUCKLE



SLOT TRACK



STAINLESS



BRASS



CARBON FIBER





## BIG SUCKER™ STAGE II AIR CLEANER KITS

- ▶ Stage II Big Sucker™ retains all the performance gaining features of the Stage I kit but include a 20% larger filter for even more airflow
- ▶ Each Stage II aluminum backing plate features our patented hidden breather technology and radius air inlet for maximum performance
- ▶ Require custom Ness cover, factory air cleaner covers will not fit
- ▶ Performance air filters available in standard red pre-oiled cotton, or synthetic black stainless steel jacketed filter elements
- ▶ Backing plates available in standard, black or chrome finish
- ▶ Each kit includes backing plate, performance air filter, gaskets, breathers and all other necessary hardware

50-575



STAGE II

SMOOTH STAGE II

08-16 FLT  
16-17 SOFTAIL®/FXDLS

99-17 TWIN CAM  
(EXC. 99-01 FI FLT  
& FBW MODELS)

93-99  
EVO. CARB

99-01 FI FLT

88-Up XL

### BIG SUCKER™ STAGE II AIR CLEANER KITS \*

	08-16 FLT 16-17 SOFTAIL®/FXDLS	99-17 TWIN CAM (EXC. 99-01 FI FLT & FBW MODELS)	93-99 EVO. CARB	99-01 FI FLT	88-Up XL
Standard Filter / Plain Backing Plate	18-511	18-506	18-499	18-493	18-804
Standard Filter / Chrome Backing Plate	18-513	18-508	18-502	18-504	18-823
Standard Filter / Black Backing Plate	18-565	18-566	18-567	18-568	18-569
Synthetic Filter / Chrome Backing Plate	50-519	50-520	50-521	50-522	50-523
Synthetic Filter / Black Backing Plate	50-575	50-576	50-577	50-578	50-579

08-16 FLT  
16-17 SOFTAIL®/FXDLS

99-17 TWIN CAM  
(EXC. 99-01 FI FLT  
& FBW MODELS)

93-99  
EVO. CARB

99-01 FI FLT

88-Up XL

### BIG SUCKER™ STAGE II AIR CLEANER KITS W/CUSTOM COVERS

#### STANDARD FILTER \*

	08-16 FLT 16-17 SOFTAIL®/FXDLS	99-17 TWIN CAM (EXC. 99-01 FI FLT & FBW MODELS)	93-99 EVO. CARB	99-01 FI FLT	88-Up XL
Smooth Black	18-821	18-820	18-774	18-775	18-776
Smooth Chrome	18-819	18-818	18-790	18-782	18-783

#### SYNTHETIC FILTER \*

	08-16 FLT 16-17 SOFTAIL®/FXDLS	99-17 TWIN CAM (EXC. 99-01 FI FLT & FBW MODELS)	93-99 EVO. CARB	99-01 FI FLT	88-Up XL
Smooth Black	50-821	50-820	50-774	50-775	50-359
Smooth Chrome	50-819	50-818	50-790	50-782	50-783

\*These air cleaners have received a California Executive Order (Executive Order D-639-8)

**DERBY SUCKER™ AIR CLEANER KITS**

- ▶ Performance Air Cleaner Kit that accepts any 5-hole Derby cover for use as an air cleaner cover, allowing you to choose any style you wish
- ▶ Features an almost 20% larger filter than Stage I while keeping the same leg clearance (same height as Stage I filter)
- ▶ Performance air filters available in Standard red pre-oiled cotton, or synthetic black stainless steel jacketed filter elements (Synthetic recommended for exposed air cleaner configurations)
- ▶ Backing plates available in standard, black or chrome finish
- ▶ Each kit includes backing plate, performance filter, gasket & necessary hardware



DERBY SUCKER / BLACK



08-16 FLT  
16-17 SOFTAIL®/FXDLS

99-17 TWIN CAM  
(EXC. 99-01 FI FLT  
& FBW MODELS)

93-99  
EVO. CARB

99-01  
FI FLT

88-Up XL

**DERBY SUCKER™ \***

Standard Derby Sucker Kit, Chrome	18-380	18-381	18-382	18-383	18-384
Standard Derby Sucker Kit, Black	18-385	18-386	18-387	18-388	18-389
Synthetic Derby Sucker Kit, Chrome	50-370	50-371	50-372	50-373	50-374
Synthetic Derby Sucker Kit, Black	50-375	50-376	50-377	50-378	50-379

**BIG SUCKER™ AIR FILTERS FOR SCREAMING EAGLE® AIR CLEANERS**

- ▶ Big Sucker™ air filters for Screaming Eagle air cleaner kits to increase air flow, ability to add custom covers or add the water resistant synthetic feature
- ▶ Available in Standard Red, Synthetic or Derby Sucker filter elements
- ▶ Standard performance filters are constructed from red pre-oiled cotton and are washable/reusable
- ▶ Synthetic performance filters are constructed from black synthetic filter element that is wrapped in a stainless steel jacket. Synthetic filters are washable/re-usable, do not require oil and are water resistant which in most cases eliminates the need for a rain sock (recommended for exposed air cleaner configurations)
- ▶ Derby Sucker filters accept any 5-hole derby cover as an air cleaner cover and are almost 20% larger than Stage I filters for more airflow.
- ▶ Available in both standard and synthetic filter elements



SYNTHETIC / STANDARD

**STANDARD FILTERS**

- 18-098 99-17 FXST,02-07 FLT & 97-07 FXD, Standard
- 50-084 99-17 FXST, 02-07 FLT & 97-07 FXD, Synthetic
- 18-030 08-16 FLT, Standard
- 50-031 08-16 FLT, Synthetic

**DERBY STYLE FILTERS \***

- 18-312 99-17 FXST, 02-07 FLT & 97-07 FXD, Standard
- 50-313 99-17 FXST, 02-07 FLT & 97-07 FXD, Synthetic
- 50-311 08-16 FLT, Synthetic



DERBY FILTERS  
SYNTHETIC / STANDARD

\*These air cleaners have received a California Executive Order (Executive Order D-639-8)



SMOOTH



BEVELED



10-GAUGE



KNUCKLE



SLOT TRACK



CARBON FIBER



BRASS



STAINLESS STEEL



18-761

### CUSTOM COVERS FOR BIG SUCKER™ AIR CLEANERS

- ▶ Custom cover options for Stage I and II Big Sucker™ kits for an exposed look and unique style
- ▶ Covers will fit all Arlen Ness Big Sucker™ kits except kits specifically designed for use of factory air cleaner cover; be sure to choose your appropriate Stage Kit
- ▶ Stage I Smooth covers are stamped from steel and finished in chrome and black powdercoat finish. Brushed stainless and brass also now available
- ▶ Stage I Beveled, 10-Gauge, Slot Track, Scalloped and all new Knuckle covers are machined from billet aluminum
- ▶ Stage I carbon fiber covers are made from pure carbon fiber
- ▶ Stage II covers are available in Smooth, Beveled, 10-Gauge, Knuckle, Slot Track, Carbon Fiber;
- ▶ Brass and stainless steel styles
- ▶ Each cover is sold individually and includes mounting hardware

### STAGE I COVERS

18-762	10-Gauge, Black
18-763	10-Gauge, Chrome
18-777	Slot Track, Black
18-778	Beveled, Chrome
18-779	Beveled, Black
18-760	Smooth, Chrome
18-761	Smooth, Black
18-769	Knuckle, Black
18-768	Knuckle, Chrome
18-767	Carbon Fiber
18-765	Brass
18-764	Brushed Stainless Steel

### STAGE II COVERS

18-770	Smooth Chrome
18-771	Smooth Black

**RE-CHARGE KITS FOR BIG SUCKER™ AIR FILTERS**

- ▶ Cleans, oils and restores your Big Sucker™ filter to almost new
- ▶ Over time dirt and debris will collect in the filter element and can reduce airflow, these kits re-charge your filter for optimum airflow
- ▶ Available for pre-oiled red, black stainless steel jacketed and black M8 filters
- ▶ Each kit includes 1 bottle of filter cleaner and 1 bottle of filter oil

<b>18-075</b>	Clear filter oil / Cleaner kit for stainless & black filters
<b>18-076</b>	Red filter oil / Cleaner kit for red filters
<b>18-077</b>	Black filter oil / Cleaner kit for black filters



CLEAR OIL      RED OIL      BLACK OIL

**RAIN SOCKS FOR BIG SUCKER™ AIR CLEANER KIT**

- ▶ Pre-filters or Rain Socks are outer jackets for your Big Sucker™ air cleaner kits that are water resistant for riding in wet conditions
- ▶ Available for Stage I & Stage II kits
- ▶ Recommended for pre-oiled cotton performance filters

<b>18-060</b>	Stage I Pre-Filter / Rain Sock
<b>18-061</b>	Stage II Pre-Filter / Rain Sock



STAGE I      STAGE II

	08-16 FLT 16-17 SOFTAIL®/FXDLS	99-17 TWIN CAM (EX. 99-01 FI FLT & 08-17 FLT)	08-16 FXD,OEM COVER (except models with round covers)	93-99 EVO	99-01 FI FLT	88-Up XL	88-Up XL,OEM COVER
--	-----------------------------------	---	--	--------------	-----------------	-------------	--------------------------

**STAGE I ACCESSORIES**

Replacement Backing Plate, Plain	18-580	18-581	N/A	18-582	18-583	18-584	18-584
Replacement Backing Plate, Black	18-590	18-591	N/A	18-592	18-593	18-594	18-594
Replacement Backing Plate, Chrome	18-585	18-586	18-586	18-587	18-588	18-589	18-589
Replacement Hardware Kit	18-530	18-531	N/A	18-532	18-533	18-534	18-534
Replacement Gasket Kit	18-535	18-536	N/A	18-536	18-537	18-538	18-538
Replacement Synthetic Filter	50-083	50-084	N/A	50-084	50-087	50-084	N/A
Replacement Standard Filter	18-080	18-098	*18-041	18-098	18-097	18-098	18-040
Replacement Black Pre-Oiled Filter for M8 round & "Method" Series Clear Air Cleaners							18-090

\*Designed to use stock OEM outer cover only

	08-16 FLT 16-17 SOFTAIL®/FXDLS	99-17 TWIN CAM (EX. 99-01 FI FLT & 08-17 FLT)	93-99 EVO	99-01 FUEL INJECT- ED FLT	88-Up XL
--	-----------------------------------	---	--------------	---------------------------------	----------

**STAGE II ACCESSORIES**

Backing Plate Only, Plain	18-580	18-581	18-582	18-583	18-584
Backing Plate Only, Chrome	18-585	18-586	18-587	18-588	18-589
Backing Plate Only, Black	18-590	18-591	18-592	18-593	18-594
Hardware Kit, Stage II	18-539	18-539	18-541	18-542	18-543
Gasket Kit	18-535	18-536	18-536	18-537	18-538
Standard Stage II Filter	18-081	18-099	18-099	18-099	18-099
Synthetic Stage II Filter	50-085	50-086	50-086	50-086	50-086

**DERBY SUCKER ACCESSORIES**

Derby Sucker Hardware Kit	18-544	18-545	18-546	18-547	18-548
Derby Sucker Gasket Kit	18-535	18-536	18-536	18-537	18-538
Standard Replacement Filter	18-301	18-303	18-303	18-305	18-303
Synthetic Replacement Filter	50-300	50-302	50-302	50-304	50-302

\*These air cleaners have received a California Executive Order (Executive Order D-639-B)



81-034

## MONSTER SUCKER 90° AIR CLEANERS

- ▶ Our Monster Sucker 90° Air Cleaner Kit features our patented Big Sucker™ "hidden breather" technology and more filter surface area than any other aftermarket 90° on the market for maximum performance
- ▶ Ness hidden breathers are o-ringed at the heads and exit out the mouth of the injector/carb to provide efficient engine breathing, eliminating the need for any external hoses or hardware
- ▶ The inverted 90° style filter features a built in inverted top to pull in air not only from all sides of the filter but also the front, which results in more performance gaining airflow
- ▶ Each filter is constructed from a synthetic material that is water resistant, which in most cases eliminates the need for a rain sock
- ▶ Filters are re-usable and do not require oil, just wash and re-use
- ▶ Kits for models w/ Milwaukee-Eight® engine include throttle servo cover
- ▶ Covers are forged from billet aluminum then CNC machined to perfection
- ▶ Kits are available with or without forged billet covers
- ▶ Forged billet covers can be added at any time to any Standard Monster Sucker Kits that were originally purchased without covers
- ▶ Each kit includes backing plate, 90° elbow, filter, filter cover (if cover kit is chosen), gaskets and necessary hardware

### STANDARD [NO COVER KITS] \*    BLACK    CHROME

00-17 Twin Cam (Exc. FBW & 99-01 FI FLT)	81-000	81-001
08-16 FLT/16-17 Softail®/ FXDLS	81-005	81-006
88-Up XL	81-010	81-011
17-Up M8 models	81-039	81-034

### BLACK, COVER KITS \*    10-GAUGE    DEEP CUT    BEVELED

00-17 Twin Cam (Exc. FBW & 99-01 FI FLT)	81-002	81-004	81-003
08-16 FLT/16-17 Softail®/FXDLS	81-007	81-009	81-008
88-Up XL	81-012	81-014	81-013
17-Up M8 models	81-035	81-037	81-036

### CHROME, COVER KITS \*    10-GAUGE    DEEP CUT    BEVELED

00-17 Twin Cam (Exc. FBW & 99-01 FI FLT)	81-022	81-024	81-023
08-16 FLT/16-17 Softail®/FXDLS	81-027	81-029	81-028
88-Up XL	81-017	81-019	81-018
17-Up M8 models	81-030	81-032	81-031

### COVER ONLY \*    10-GAUGE    DEEP CUT    BEVELED

Chrome	81-101	81-103	81-105
Black	81-100	81-102	81-104

### MONSTER SUCKER ACCESSORIES \*

81-110	Monster Sucker Replacement Filter
18-065	Rain Sock (no cover kits)
18-063	Rain Sock Cover Kits

\* These air cleaners have received a California Executive Order (Executive Order D-639-8)



STANDARD

10-GAUGE

DEEP CUT

BEVELED

**VELOCITY 65 AIR CLEANERS**

- ▶ Features patented "hidden breather" technology and a forward facing 65° intake angle that produces some of the highest air flow performance numbers [CFM] we have tested
- ▶ Ness hidden breathers are o-ringed at the heads and exit out of the mouth of the injector/carb to provide efficient engine breathing, eliminating the need for any external hoses or hardware
- ▶ Integrated radius air inlet for performance gaining unobstructed airflow
- ▶ Milwaukee-Eight® engine applications include a throttle servo cover
- ▶ Inverted 65 style filter features a built-in inverted top to pull in air not only from all sides of the filter but also the front, which directs more performance gaining airflow into your engine
- ▶ Each washable filter is constructed from synthetic material that is water resistant
- ▶ Only M8 kits include servo/throttle body cover

VELOCITY 65*	BLACK	CHROME
00-17 Twin Cam (Exc. FBW & 99-01 FI FLT)	81-204	81-205
08-16 FLT/16-17 Softail®/ FXDLS	81-202	81-203
88-Up XL	81-206	81-207
17-Up M8 models*	81-200	81-201

VELOCITY 65 ACCESSORIES	
V65 Rain Sock	18-064
Replacement Filter, Chrome	81-209
Replacement Filter, Black	81-209

\* Only M8 models come with cover

\* These air cleaners have received a California Executive Order (Executive Order D-639-8)



81-200





DRIFT, BLACK

### FORGED BILLET ALUMINUM BACKING PLATE

FOR: INVERTED / METHOD / CLEAR TEAR / SIDEKICK

#### Patent-Pending Breather Tech

Patent-pending hidden breather technology is o-ringed at the heads, passes through the back plate and exits inside the throttle body through proprietary shooter tubes. Now standard on all inverted intakes

#### Patent-Pending Oil Catch

New integrated oil catch ensures no engine breather oil ever ends up on your filter restricting airflow. Oil catch's bolt-on design allows it to be serviced when its time to service the air filter.



#### Hidden Hardware

Specially designed breather bolts and billet cover plates result in a hidden hardware design with the most efficient breathing system available

#### Radius Air Inlet

Forged into the backing plate, radius air inlet provides unobstructed airflow for more horsepower and torque

## INVERTED AIR CLEANER SERIES

The Inverted air cleaner series features our next generation patent-pending hidden breather technology and an inverted intake design that maximizes airflow by pulling in air from the face of the air cleaner, as well the perimeter of the filter. Each kit is machined entirely from forged billet aluminum to provide the best performance and style

### FORGED ALUMINUM BACKING PLATE

- ▶ Each backing plate is CNC machined from forged aluminum
- ▶ Features the patented Big Sucker™ hidden breather technology
- ▶ Each hidden breather is o-ringed at the heads, passes through the backing plate and exits at the mouth of the throttle body through proprietary shooter tubes- this eliminates the need for any external hoses or hardware
- ▶ Radius air inlet provides unobstructed airflow
- ▶ Specially designed breather is hidden for a clean finish
- ▶ Eliminates oil blow-by issues associated with MB performance intakes
- ▶ Patent-pending oil catch integrated into the backing plate, reservoir is serviceable

### SYNTHETIC AIR FILTER

- ▶ Handmade in the U.S.A.
- ▶ Does not need oil, just wash and re-use for a long lasting performance
- ▶ Water resistant, which in most cases eliminates the need for a rain sock
- ▶ Each filter features an inverted pleated top with pleated sides to maximize airflow by pulling in from every angle
- ▶ Synthetic material is black, with a stainless steel jacket

### FORGED BILLET ALUMINUM AIR FILTER HOUSINGS

- ▶ Machined from a single piece of forged billet aluminum
- ▶ Features an inverted intake face that acts as a velocity stack to increase performance by forcing air into the inverted air filter top

**SLOT TRACK\***                      **CHROME**   **BLACK**

08-16 FLT/16-17 Softail®/FXDLS	18-920	18-921
00-17 Twin Cam (Exc. FBW & 99-01 FI FLT)	18-922	18-923
91-Up XL Sportster®	18-924	18-925
17-Up M8 Models	18-914	18-915

**DEEP CUT\***                      **CHROME**   **BLACK**

08-16 FLT/16-17 Softail®/FXDLS	18-926	18-927
00-17 Twin Cam (Exc. FBW & 99-01 FI FLT)	18-928	18-929
91-Up XL Sportster®	18-930	18-931
17-Up M8 Models	18-916	18-917

**15 SPOKE\***                      **CHROME**   **ALL BLACK**

08-16 FLT/16-17 Softail®/FXDLS	18-990	18-991
00-17 Twin Cam (Exc. FBW & 99-01 FI FLT)	18-992	18-993
91-Up XL Sportster®	18-994	18-995
17-Up M8 Models	18-996	18-997

**DRIFT\***                      **CHROME**   **BLACK**

08-16 FLT/16-17 Softail®/FXDLS	18-980	18-981
00-17 Twin Cam (Exc. FBW & 99-01 FI FLT)	18-982	18-983
91-Up XL Sportster®	18-984	18-985
17-Up M8 Models	18-986	18-987

**BEVELED\***                      **CHROME**   **BLACK**

08-16 FLT/16-17 Softail®/FXDLS	18-932	18-933
00-17 Twin Cam (Exc. FBW & 99-01 FI FLT)	18-934	18-935
91-Up XL Sportster®	18-936	18-937
17-Up M8 Models	18-918	18-919

**10-GAUGE\***                      **CHROME**   **BLACK**

08-16 FLT/16-17 Softail®/FXDLS	18-940	18-941
00-17 Twin Cam (Exc. FBW & 99-01 FI FLT)	18-942	18-943
91-Up XL Sportster®	18-944	18-945
17-Up M8 Models	18-946	18-947

**10-GAUGE\***                      **TITANIUM**   **ALL BLACK**

08-16 FLT/16-17 Softail®/FXDLS	600-013	600-009
00-17 Twin Cam (Exc. FBW & 99-01 FI FLT)	600-014	600-010
91-Up XL Sportster®	600-015	600-011
17-Up M8 Models	600-016	600-008

**INVERTED SERIES ACCESSORIES\***

Replacement Synthetic Inverted Filter	18-938
Rain Sock	18-062

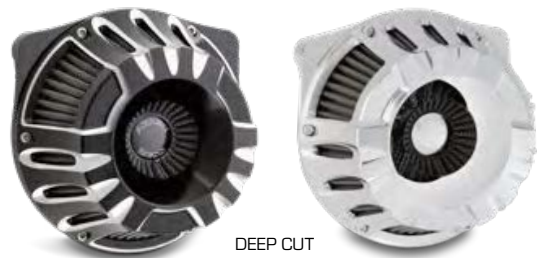

DEEP CUT



15 SPOKE



DRIFT



BEVELED



SLOT TRACK



10-GAUGE



10-GAUGE, ALL BLACK

10-GAUGE, TITANIUM

\*These air cleaners have received a California Executive Order (Executive Order D-639-8)



### METHOD AIR CLEANER SERIES

The Method is a forged billet aluminum air cleaner that features a smooth and sculpted CNC machined design. It's clear polycarbonate top provides a window into the inside of your engine's intake system.

- ▶ Next generation patent-pending hidden breather technology
- ▶ Hidden breathers are o-ringed at the heads, pass through the backing plate and exit inside the mouth of the throttle body through proprietary shooter tubes
- ▶ Hard coated clear polycarbonate top
- ▶ Black pre-oiled high performance filter
- ▶ CNC machined from forged billet aluminum
- ▶ Integrated patent-pending oil catch/reservoir



**CONTRAST\***

18-961	08-16 FLT/16-17 Softail®/FXDLS
18-962	00-17 Twin Cam (except Fly by Wire)
18-963	88-Up XL Sportster®
18-960	17-Up M8 Models

**ALL BLACK\***

18-966	08-16 FLT/16-17 Softail®/FXDLS
18-967	00-17 Twin Cam (except Fly by Wire)
18-968	88-Up XL Sportster®
18-965	17-Up M8 Models

**CHROME\***

18-971	08-16 FLT/16-17 Softail®/FXDLS
18-972	00-17 Twin Cam (except Fly by Wire)
18-973	88-Up XL Sportster®
18-970	17-Up M8 Models

**BLUE\***

18-181	08-16 FLT/16-17 Softail®/FXDLS
18-182	00-17 Twin Cam (except Fly by Wire)
18-183	88-Up XL Sportster®
18-180	17-Up M8 Models

**RED\***

18-171	08-16 FLT/16-17 Softail®/FXDLS
18-172	00-17 Twin Cam (except Fly by Wire)
18-173	88-Up XL Sportster®
18-170	17-Up M8 Models

**GOLD\***

18-176	08-16 FLT/16-17 Softail®/FXDLS
18-177	00-17 Twin Cam (except Fly by Wire)
18-178	88-Up XL Sportster®
18-175	17-Up M8 Models

**ORANGE\***

18-185	08-16 FLT/16-17 Softail®/FXDLS
18-186	00-17 Twin Cam (except Fly by Wire)
18-187	88-Up XL Sportster®
18-184	17-Up M8 Models

**TITANIUM\***

600-017	08-16 FLT/16-17 Softail®/FXDLS
600-018	00-17 Twin Cam (except Fly by Wire)
600-019	88-Up XL Sportster®
600-016	17-Up M8 Models

**METHOD ACCESSORIES\***

18-062	Rain Sock
18-090	Replacement Filter



\*These air cleaners have received a California Executive Order (Executive Order D-639-8)



NEW

### SIDEKICK AIR CLEANER SERIES

- ▶ The Sidekick Air Cleaner combines forged billet aluminum, clear polycarbonate, and an angled shape for the best in function and style
- ▶ Forged and CNC machined into an angled shape for excellent leg room
- ▶ Integrated polycarbonate top is coated for long term durability
- ▶ Patented hidden breather backing plate technology
- ▶ Breather design is o-ringed at the heads, passes through the backing plate and exits inside the mouth of the throttle body through proprietary shooter tubes
- ▶ All applications feature an integrated patented oil-catch to ensure no oil reaches the air filter and restricts air flow
- ▶ Filter is made from black synthetic material wrapped in stainless steel mesh
- ▶ Filters are washable and water resistant



SIDEKICK ALL BLACK



SIDEKICK CHROME



#### ALL BLACK\*

81-302 08-16 FLT/16-17 Softail®/FXDLS

81-304 00-17 Twin Cam [except Fly by Wire]

81-306 88-Up XL Sportster®

81-300 17-Up M8 Models

#### CHROME\*

81-303 08-16 FLT/16-17 Softail®/FXDLS

81-305 00-17 Twin Cam [except Fly by Wire]

81-307 88-Up XL Sportster®

81-301 17-Up M8 Models

#### TITANIUM\*

81-310 08-16 FLT/16-17 Softail®/FXDLS

81-312 00-17 Twin Cam [except Fly by Wire]

81-314 88-Up XL Sportster®

81-308 17-Up M8 Models

\* These air cleaners have received a California Executive Order (Executive Order D-639-B)





**NEW**

### CLEAR TEAR AIR CLEANER SERIES

- ▶ The Clear Tear Air Cleaner Series brings the timeless teardrop shape to a new level
- ▶ Smooth flowing cage design is forged and CNC machined to a perfect finish
- ▶ Specially formed radius shaped polycarbonate top is hard coated for long term durability
- ▶ Radius polycarbonate window can be installed in both the front or back facing direction allowing the rider to choose their preferred look
- ▶ Patented hidden breather backing plate technology
- ▶ Breather design is o-ringed at the heads, passes through the backing plate and exits inside the mouth of the throttle body through proprietary shooter tubes
- ▶ Integrated patented oil-catch to ensure no oil reaches the air filter and restricts air flow
- ▶ Performance air filter is made from black pre-oiled cotton and is washable



**ALL BLACK\***

18-977	08-16 FLT/16-17 Softail®/FXDLS
18-979	00-17 Twin Cam (except Fly by Wire)
18-998	88-Up XL Sportster®
18-999	17-Up M8 Models



ALL BLACK

**CHROME\***

18-976	08-16 FLT/16-17 Softail®/FXDLS
18-979	00-17 Twin Cam (except Fly by Wire)
18-988	88-Up XL Sportster®
18-989	17-Up M8 Models



CHROME

**BLUE\***

18-903	08-16 FLT/16-17 Softail®/FXDLS
18-911	00-17 Twin Cam (except Fly by Wire)
18-949	88-Up XL Sportster®
18-975	17-Up M8 Models



BLUE

**RED\***

18-901	08-16 FLT/16-17 Softail®/FXDLS
18-904	00-17 Twin Cam (except Fly by Wire)
18-913	88-Up XL Sportster®
18-969	17-Up M8 Models



RED

**GOLD\***

18-902	08-16 FLT/16-17 Softail®/FXDLS
18-912	00-17 Twin Cam (except Fly by Wire)
18-948	88-Up XL Sportster®
18-974	17-Up M8 Models



GOLD

**ORANGE\***

600-001	08-16 FLT/16-17 Softail®/FXDLS
600-002	00-17 Twin Cam (except Fly by Wire)
600-003	88-Up XL Sportster®
600-000	17-Up M8 Models



ORANGE

**TITANIUM\***

600-005	08-16 FLT/16-17 Softail®/FXDLS
600-006	00-17 Twin Cam (except Fly by Wire)
600-007	88-Up XL Sportster®
600-004	17-Up M8 Models



TITANIUM

\*These air cleaners have received a California Executive Order (Executive Order D-639-8)





35-158

### ARLEN NESS BY MAGNAFLOW™ SLIP-ON MUFFLERS

- ▶ 4.5" Slip-On Mufflers deliver deep rich sound and performance gains
- ▶ Hi-Flow and maintenance free stainless steel louver core baffles
- ▶ Exclusive inner-wall thermal construction reduces temperature
- ▶ Available in Deep Cut, Redline and Megacone styles
- ▶ Deep Cut and Redline mufflers feature end caps that are CNC machined from billet aluminum.
- ▶ Megacone mufflers feature an inverted end cap for a clean look
- ▶ Muffler bodies available in chrome or black finish
- ▶ Easy installation to factory or aftermarket headpipes
- ▶ Designed by Ness and made by Magnaflow in the USA



REDLINE



MEGACONE



DEEP CUT

#### REDLINE

- 35-150** Redline Slip-Ons muffler set, 95-16 Touring, Chrome [California Application 95-16 only]
- 35-151** Redline Slip-Ons muffler set, 95-16 Touring, Black [California Application 95-16 only]
- 35-148** Redline Slip-Ons muffler set, 17-Up Touring, Chrome [California Application 17-Up only]
- 35-149** Redline Slip-Ons muffler set, 17-Up Touring, Black [California Application 17-Up only]

#### MEGACONE

- 35-157** Megacone Slip-Ons muffler set, Chrome [California Application for 95-16 only]
- 35-158** Megacone Slip-Ons muffler set, Black [California Application for 95-16 only]

#### DEEP CUT

- 35-152** Deep Cut Slip-Ons muffler set, 95-16 Touring, Chrome [California Application 95-16 only]
- 35-153** Deep Cut Slip-Ons muffler set, 95-16 Touring, Black [California Application 95-16 only]
- 35-154** Deep Cut Slip-Ons muffler set, 17-Up Touring, Chrome [California Application 17-Up only]
- 35-155** Deep Cut Slip-Ons muffler set, 17-Up Touring, Black [California Application 17-Up only]



05-545

**ARLEN NESS BY MAGNAFLOW™ 18-Up FATBOB SLIP-ON MUFFLERS**

- ▶ Pro Short & Pro Flow Slip-Ons deliver deep sound and upgrade the performance on 18-Up Fatbob models
- ▶ 4.5" Competition mufflers feature hi-flow, maintenance free, stainless steel lower core baffles that deliver torque and horsepower
- ▶ Eliminates unsightly factory exhaust shrouds
- ▶ All mounting hardware is included with the set of mufflers, each set also includes black button head allens to upgrade style
- ▶ Made in the USA by Magnaflow

**PRO SHORT**

**05-935** Pro Short muffler set, 18-Up Fatbob, Black

**PRO FLOW**

**05-945** Pro Flow muffler set, 18-Up Fatbob, Black



**SUPER CLAMPS FOR SLIP-ON MUFFLERS**

- ▶ The cleanest and strongest muffler clamps available
- ▶ CNC machined from billet aluminum
- ▶ Looks great with your favorite aftermarket mufflers or custom exhaust applications
- ▶ Available for 1 - 3/4" and 2 - 1/2" exhaust pipe applications
- ▶ 1 - 3/4" clamp replaces OEM part # 65295-95A & 65900012
- ▶ 2 - 1/2" clamp replaces OEM part # 65900015
- ▶ Available in chrome or high heat black coated finish
- ▶ Sold individually

**1-3/4"**

**05-940** 1 - 3/4" Clamp, Black, each

**05-941** 1 - 3/4" Clamp, Chrome, each

**2-1/2"**

**05-942** 2 - 1/2" Clamp, Black, each

**05-943** 2 - 1/2" Clamp, Chrome, each

Parts listed under California Applications may be advertised, offered for sale, or sold installed in California for specific year and model applications ONLY. Parts NOT listed under California Applications for specific year and model (49 State Federal Parts) may not be advertised, offered for sale, sold or installed in California. Dyna® Fat Bob®, Low Rider® and Switchback® fitment products may not be sold in California.



Super Muffler Clamps



TRU-DUAL

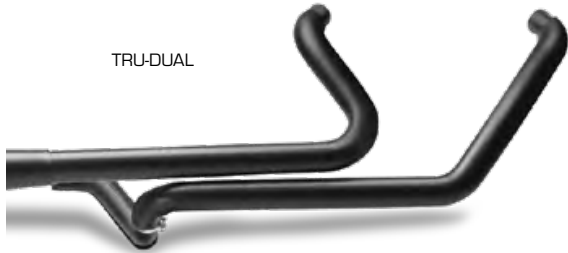

TRU-X



LOW DOWN



**TRU DUAL & TRU-X HEAD PIPES**

- ▶ State of the art tuned length head pipes for improved, equal flow exhaust that helps generate power to the ground with an enhanced throttle feel
- ▶ Available in Tru-Dual and Tru-X styles
- ▶ Ideal for tuned engines requiring better flow or stock engines looking for improved output
- ▶ Magna-black coated stainless steel 1 - 3/4" head pipes that will never blue or rust
- ▶ 2.5" Full Coverage heat shields
- ▶ 12mm and 18mm O2 sensor ports allow for maximum tuning
- ▶ Designed by Ness and made by Magnaflow in the USA

**FITMENT**

09-16 Touring, Tri-Glide

**TRUE-DUAL HEAD PIPES**

35-120 Tru-Duals, 09-16 Touring, Chrome

35-121 Tru-Duals, 09-16 Touring, Black

**TRUE-X HEAD PIPES**

35-124 Tru-X, 09-16 Touring, Chrome

35-125 Tru-X, 09-16 Touring, Black

**LOWDOWN EXHAUST SYSTEMS**

- ▶ Custom inspired design with large sweeping bends
- ▶ Trend setting chrome billet twin clamp gives a custom look at the end of the pipes
- ▶ Increased performance and style
- ▶ Rich amazing sound quality
- ▶ 12mm and 18mm oxygen sensor ports
- ▶ Show quality chrome finish
- ▶ 2 - 1/4" full coverage heat shields
- ▶ 1 - 3/4" head pipes
- ▶ Designed by Ness and made by Magnaflow in the USA

**FITMENT**

- ▶ Dyna®: 06-17 Dyna® Excludes: Switchback. Excludes all 06-07 models with mid controls
- ▶ Softail®: 96-17 Softail®
- ▶ Sportster®: 04-Up Sportster®

**CHROME**

35-250 Lowdown, Softail®, Chrome

35-350 Lowdown, Dyna®, Chrome

35-450 Lowdown, Sportster®, Chrome

**BLACK**

35-251 Lowdown, Softail®, Black

35-351 Lowdown, Dyna®, Black

35-451 Lowdown, Sportster®, Black

Parts listed under California Applications may be advertised, offered for sale, sold or installed in California for specific year and model applications ONLY. Parts NOT listed under California Applications for specific year and model (49 State Federal Parts) may not be advertised, offered for sale, sold or installed in California. Dyna® Fat Bob®, Low Rider® and Switchback® fitment products may not be sold in California.

- ▶ Aggressive looking 2 in 1 performance design
- ▶ Deep black muffler with innovative gloss black inverted end cap
- ▶ Deep powerful sound quality
- ▶ 12mm and 18mm oxygen sensor ports
- ▶ 2 - 1/2" deep black & chrome full coverage heat shields
- ▶ 1 - 3/4" head pipes
- ▶ Designed by Ness and made by Magnaflow in the USA

**FITMENT**

- ▶ Dyna®: 06-17 Dyna® Excludes: Switchback. Excludes all 06-07 models with mid controls
- ▶ Softail®: 96-17 Softail®
- ▶ Sportster®: 08-Up Sportster®

**CHROME**

- 35-354** F-Bomb, Dyna®, Chrome
- 35-254** F-Bomb, Softail®, Chrome
- 35-452** F-Bomb, Sportster®, Chrome

**BLACK**

- 35-355** F-Bomb, Dyna®, Black
- 35-255** F-Bomb, Softail®, Black
- 35-453** F-Bomb, Sportster®, Black





Harley-Davidson

DAVIDSON  
1000

VALVE  
COVER

A close-up photograph of a motorcycle's front wheel and fender. The wheel is chrome with a multi-spoke design and a disc brake. The fender is black and partially visible. The background is a blurred concrete surface with a yellow curb.

# COVERS & TRIM

## SECTION CONTENT

- 111** Fairing Vent Inserts
- 111** Inner Fairing Gauge Trim
- 112** Dash Trim
- 114** Derby & Point Covers
- 116** 10-Gauge Engine Covers
- 114** Pushrods
- 120** Engine Mounts & Links
- 121** Oil Pressure Gauge Kits
- 121** Oil Filters
- 122** Horn Kits
- 125** Saddlebag Latch Cover
- 125** Saddlebag Lid Levers

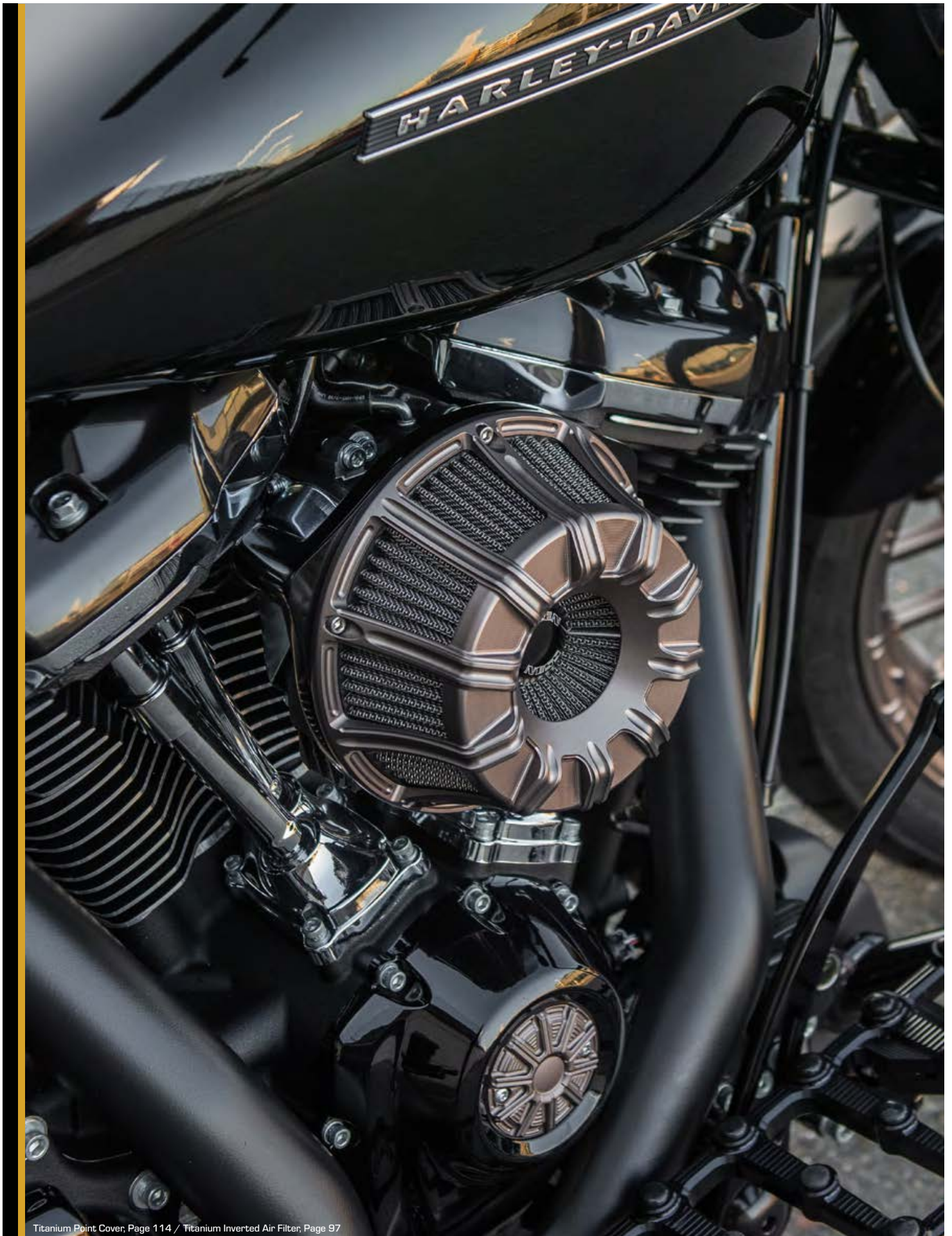

**FAIRING VENT INSERTS**

- ▶ Fairing accents forged from aluminum then CNC machined to perfection
- ▶ Add style to the factory fairing vent
- ▶ Simple installation, no disassembly of fairing required
- ▶ Choose from chrome or black anodize finish
- ▶ Choose from Deep Cut or 10-Gauge styles
- ▶ Available for 14-Up FLHX/FLHT and FLHTCUTG

**DEEP CUT**

<b>30-346</b>	Deep Cut, Chrome
<b>30-336</b>	Deep Cut, Black

**10-GAUGE**

<b>30-345</b>	10-Gauge, Chrome
<b>30-335</b>	10-Gauge, Black



DEEP CUT



10-GAUGE

**INNER FAIRING GAUGE TRIM**

- ▶ Adds style to your inner fairing and gauges
- ▶ One-piece design surrounds all four gauges and fills recessed area in factory inner fairing
- ▶ CNC machined from billet aluminum
- ▶ Simple & fast installation
- ▶ Available in Deep Cut, 10-Gauge and Beveled styles
- ▶ Each style has matching speaker grills & tank dash accessories for a complete look
- ▶ Fits 14-Up FLHT/FLHX/FLHTCUTG

**10-GAUGE**

<b>30-340</b>	10-Gauge, Chrome
<b>30-330</b>	10-Gauge, Black

**DEEP CUT**

<b>30-342</b>	Deep Cut, Chrome
<b>30-332</b>	Deep Cut, Black

**BEVELED**

<b>30-341</b>	Beveled, Chrome
<b>30-331</b>	Beveled, Black



10-GAUGE



DEEP CUT



BEVELED





10-GAUGE



DEEP CUT



SLOT TRACK



BEVELED

### BILLET DASH ACCESSORY PACKS

- ▶ CNC machined billet trim designed to enhance factory tank dash's
- ▶ These complete kits include the ignition switch cover, fuel door and dash insert
- ▶ Finished in chrome or black anodize with an aluminum contrast
- ▶ Fitment: 08-13 FLT Touring (Street Glide FLHX/Road Glide FLTRX) & 14-Up Fit Touring (Street Glide FLHX/Road Glide FLRX)

#### 08-13 FLHX / FLRX

91-134	10-Gauge, Chrome
91-136	10-Gauge, Black
91-124	Deep Cut, Chrome
91-126	Deep Cut, Black
91-114	Beveled, Chrome
91-116	Beveled, Black
91-106	Slot Track, Black

#### 14-Up FLHX / 15-Up FLTRX

91-135	10-Gauge, Chrome
91-137	10-Gauge, Black
91-125	Deep Cut, Chrome
91-127	Deep Cut, Black
91-115	Beveled, Chrome
91-117	Beveled, Black
91-107	Slot Track, Black



## IGNITION SWITCH COVERS

- ▶ Ignition switch cover made from CNC machined billet aluminum
- ▶ Mounts over factory ignition switch
- ▶ Fitment: 07-13 FLT Touring (FLHT/FLHX/FLTR) and 14-Up FLT Touring (FLHX/FLHT/FLHTCUTG/FLTRX/FLTRU/FLTRK)

	07-13	14-Up
Slot Track, Black	N/A	04-187
Beveled, Chrome	04-166	04-188
Beveled, Black	04-167	04-189
Deep Cut, Chrome	04-190	04-192
Deep Cut, Black	04-191	04-193
10-Gauge, Chrome	04-210	04-212
10-Gauge, Black	04-211	04-213



10-GAUGE

BEVELED



DEEP CUT

SLOT TRACK

## FUEL DOORS

- ▶ Fuel doors made from CNC machined billet aluminum
- ▶ Replaces factory fuel door, accepts factory lock assembly and mounting hardware
- ▶ Finished in chrome or black anodize with an aluminum accent
- ▶ Fitment: 08-Up FLT Touring (FLTR/FLHT/FLHX)

### 08-UP FLTR / FLHT / FLHX / H-D FL TRIKE

04-149	Slot Track, Black
04-160	Beveled, Chrome
04-161	Beveled, Black
04-168	Deep Cut, Chrome
04-169	Deep Cut, Black
04-216	10-Gauge, Chrome
04-217	10-Gauge, Black



10-GAUGE

BEVELED



DEEP CUT

SLOT TRACK

## BILLET DASH INSERTS

- ▶ Decorative inserts designed for factory FLT tank dash's
- ▶ Each insert is CNC machined from billet aluminum
- ▶ Fitment: 08-Up FLT Touring (FLHX/FLTRX) & 08-Up (FLHT/FLHTC)

### 08-Up ELECTRA GLIDE MODELS (FLHT/FLHTC)

04-155	Slot Track, Black
04-196	Deep Cut, Black
04-143	Beveled, Black
04-221	10-Gauge, Black
04-194	Deep Cut, Chrome
04-141	Beveled, Chrome
04-220	10-Gauge, Chrome

### 08-Up STREET AND ROAD GLIDE MODELS (FLHX/FLTRX)

04-146	Slot Track, Black
04-185	Deep Cut, Black
04-165	Beveled, Black
04-223	10-Gauge, Black
04-184	Deep Cut, Chrome
04-164	Beveled, Chrome
04-222	10-Gauge, Chrome

### 99-07 FLT TOURING (FLHS/FLTR/FLT/FLHT/FLHTC/FLTC)

04-225	10-Gauge, Black
--------	-----------------

#### 08-Up FLHX/FLTRX



BEVELED

10-GAUGE

SLOT TRACK

DEEP CUT

#### 08-15 FLHR



DEEP CUT

10-GAUGE

SLOT TRACK

BEVELED



10-GAUGE TITANIUM POINT COVER



BLACK CONTRAST



CHROME



TITANIUM



ALL BLACK



BLUE



ORANGE



RED



GOLD

### DERBY & POINT COVERS

- ▶ Each Derby and Point Cover is CNC machined from billet aluminum
- ▶ Mounting hardware included with each cover
- ▶ Point cover Fitment: 99-17 Twin Cam (5-hole) & 17-Up M8 (2-hole)
- ▶ Derby cover fitment: 16-Up FLT Touring & 15-Up FLHTCUL/FLHTKL/99-17 Twin Cam  
18 M8 Softail® [Except: 16-Up FLT/18-FLSB/19-Up Softail®]

#### 10-GAUGE DERBY COVERS

CONTRAST/CHROME / TITANIUM / ALL BLACK / BLUE / RED / ORANGE / GOLD

99-17 TWIN CAM & 18 M8 SOFTAIL (EXC. 16-Up FLT/ 18 FLSB/ 19-Up SOFTAIL®) 700-018 700-017 700-023 700-016 700-019 700-022 700-021 700-020

16-Up FLT Touring & 15-Up FLHTCUL/FLHTKL 700-002 700-001 700-007 700-000 700-003 700-006 700-005 700-004

#### 10-GAUGE POINT COVERS

CONTRAST/CHROME / TITANIUM / ALL BLACK / BLUE / RED / ORANGE / GOLD

99-17 TWIN CAM (5-HOLE) 700-026 700-025 700-031 700-024 700-027 700-030 700-029 700-028

17-Up M8 (2-HOLE) 700-010 700-009 700-015 700-008 700-011 700-014 700-013 700-012



BEVELED

DEEP CUT II



DEEP CUT

SLOT TRACK

**DERBY COVERS****DEEP CUT / DEEP CUT II / SLOT TRACK / BEVELED**

99-17 TWIN CAM &amp; 18 M8 SOFTAIL (EXC. 16-Up FLT/18 FL5B/19-Up SOFTAIL\*), BLACK

03-579

30-310

N/A

03-472

99-17 TWIN CAM &amp; 18 M8 SOFTAIL (EXC. 16-Up FLT/18 FL5B/19-Up SOFTAIL\*), CHROME

03-570

30-311

N/A

03-477

16-Up FLT Touring &amp; 15-Up FLHTCUL/FLHTKL, BLACK

N/A

N/A

03-344

03-341

16-Up FLT Touring &amp; 15-Up FLHTCUL/FLHTKL, CHROME

N/A

30-313

N/A

03-351

**POINT COVERS****DEEP CUT / DEEP CUT II / SLOT TRACK / BEVELED**

99-17 TWIN CAM (5-HOLE), BLACK

03-574

30-314

03-495

03-473

99-17 TWIN CAM (5-HOLE), CHROME

03-573

N/A

N/A

03-478

17-Up M8 POINT (2-HOLE), CHROME

N/A

03-326

N/A

03-328

17-Up M8 POINT (2-HOLE), BLACK

N/A

03-327

03-330

N/A





10-GAUGE M8

### 10-GAUGE ENGINE COVERS CONTRAST

- ▶ Each cover in the 10-Gauge engine collection is CNC machined from forged billet aluminum
- ▶ Designed for Twin Cam and M8 engines
- ▶ Mounting hardware included
- ▶ Black anodize finish w/ aluminum contrast

#### TWIN CAM CONTRAST

<b>03-963</b>	10G Cam Cover, 01-17 Twin Cam
<b>18-253</b>	10G Rocker Box Covers, 99-17 Twin Cam
<b>03-813</b>	10G Transmission Side Cover; Cable 07-13 FLT/07-17 Softail®/06-17 FXD
<b>03-823</b>	10G Transmission Side Cover; Hydraulic 14-Up FLT
<b>03-853</b>	10G Transmission Top Cover; Twin Cam 07-16 FLT/07-17 Softail®/06-17 FXD
<b>12-573</b>	10G Billet Lifter Blocks, 99-17 Twin Cam
<b>03-633</b>	10G Pushrod Covers, 99-17 Twin Cam]

#### MILWAUKEE-EIGHT® CONTRAST

<b>03-983</b>	10G Cam Cover, 17-Up M8
<b>18-263</b>	10G Rocker Box Covers, 17-Up M8
<b>03-823</b>	10G Transmission Side Cover; Hydraulic 14-Up FLT
<b>03-863</b>	10G Transmission Top Cover, 17-Up M8
<b>12-583</b>	10G Billet Lifter Blocks, 17-Up M8
<b>03-643</b>	10G Pushrod Covers, 17-Up M8



Rocker Box Covers, M8



Rocker Box Covers, Twin Cam



Cam Cover, Twin Cam



Cam Cover, M8



Transmission Side Cover,  
Hydraulic



Transmission Side Cover,  
Cable



Transmission Top Cover,  
Twin Cam



Transmission Top Cover,  
M8



Lifter Blocks,  
Twin Cam

Lifter Blocks,  
M8



Pushrod Covers



10-GAUGE TWIN CAM

### 10-GAUGE ENGINE COVERS CHROME

- ▶ Each cover in the 10-Gauge engine collection is CNC machined from forged billet aluminum
- ▶ Designed for Twin Cam and MB engines
- ▶ Mounting hardware included
- ▶ Chrome finish

#### TWIN CAM CHROME

<b>03-962</b>	10G Cam Cover, 01-17 Twin Cam
<b>18-252</b>	10G Rocker Box Covers, 99-17 Twin Cam
<b>03-812</b>	10G Transmission Side Cover, Cable 07-13 FLT/07-17 Softail®/06-17 FXD
<b>03-822</b>	10G Transmission Side Cover, Hydraulic 14-Up FLT
<b>03-852</b>	10G Transmission Top Cover, Twin Cam 07-16 FLT/07-17 Softail®/06-17 FXD
<b>12-572</b>	10G Billet Lifter Blocks, 99-17 Twin Cam
<b>03-632</b>	10G Pushrod Covers, 99-17 Twin Cam

#### MILWAUKEE-EIGHT® CHROME

<b>03-982</b>	10G Cam Cover, 17-Up MB
<b>18-262</b>	10G Rocker Box Covers, 17-Up MB
<b>03-822</b>	10G Transmission Side Cover, Hydraulic 14-Up FLT
<b>03-862</b>	10G Transmission Top Cover, 17-Up MB
<b>12-582</b>	10G Billet Lifter Blocks, 17-Up MB
<b>03-642</b>	10G Pushrod Covers, 17-Up MB



Rocker Box Covers, MB



Rocker Box Covers, Twin Cam



Cam Cover, Twin Cam



Cam Cover, MB

Transmission Side Cover,  
HydraulicTransmission Side Cover,  
CableTransmission Top Cover,  
Twin CamTransmission Top Cover,  
MB

Pushrod Covers

Lifter Blocks,  
MBLifter Blocks,  
Twin Cam



10-GAUGE TITANIUM

### 10-GAUGE ENGINE COVERS TITANIUM

- ▶ Each cover in the 10-Gauge engine collection is CNC machined from forged billet aluminum
- ▶ Designed for Twin Cam and M8 engines
- ▶ Mounting hardware included
- ▶ Titanium finish

#### TWIN CAM TITANIUM

<b>03-976</b>	10G Cam Cover, 01-17 Twin Cam
<b>18-257</b>	10G Rocker Box Covers, 99-17 Twin Cam
<b>03-815</b>	10G Transmission Side Cover, Cable 07-13 FLT/07-17 Softail/06-17 FXD
<b>03-827</b>	10G Transmission Side Cover, Hydraulic 14-Up FLT
<b>03-855</b>	10G Transmission Top Cover, Twin Cam 07-16 FLT/07-17 Softail/06-17 FXD
<b>12-575</b>	10G Billet Lifter Blocks, 99-17 Twin Cam
<b>03-635</b>	10G Pushrod Covers, 99-17 Twin Cam

#### MILWAUKEE-EIGHT® TITANIUM

<b>03-986</b>	10G Cam Cover, 17-Up M8
<b>18-267</b>	10G Rocker Box Covers, 17-Up M8
<b>03-827</b>	10G Transmission Side Cover, Hydraulic 14-Up FLT
<b>03-865</b>	10G Transmission Top Cover, 17-Up M8
<b>12-585</b>	10G Billet Lifter Blocks, 17-Up M8
<b>03-637</b>	10G Pushrod Covers, 17-Up M8



Rocker Box Covers, M8



Rocker Box Covers, Twin Cam



Cam Cover, Twin Cam



Cam Cover, M8



Transmission Side Cover,  
Hydraulic



Transmission Side Cover,  
Cable



Transmission Top Cover,  
Twin Cam



Transmission Top Cover,  
M8



Pushrod Covers



Lifter Blocks,  
Twin Cam



Lifter Blocks,  
M8

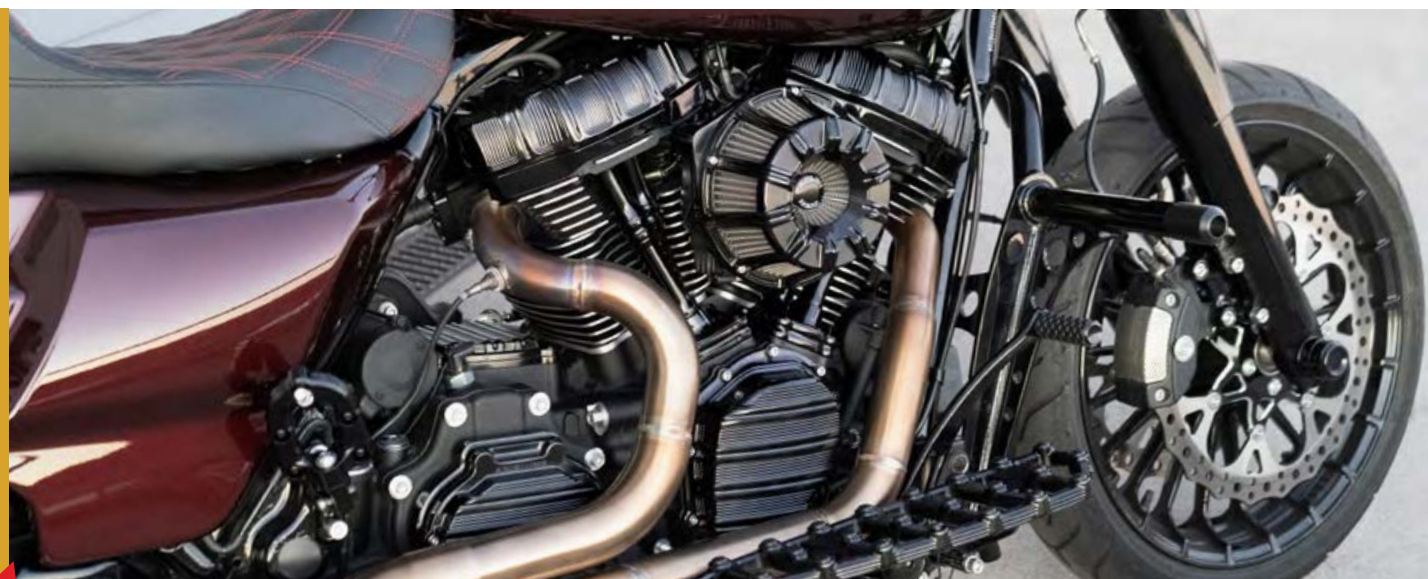

NEW

10-GAUGE ALL BLACK

### 10-GAUGE ENGINE COVERS ALL BLACK

- ▶ Each cover in the 10-Gauge engine collection is CNC machined from forged billet aluminum
- ▶ Designed for Twin Cam and M8 engines
- ▶ Mounting hardware included
- ▶ All Black finish

#### TWIN CAM ALL BLACK

<b>03-975</b>	10G Cam Cover, 01-17 Twin Cam
<b>18-256</b>	10G Rocker Box Covers, 99-17 Twin Cam
<b>03-814</b>	10G Transmission Side Cover, Cable 07-13 FLT/07-17 Softail/06-17 FXD
<b>03-826</b>	10G Transmission Side Cover, Hydraulic 14-Up FLT
<b>03-854</b>	10G Transmission Top Cover, Twin Cam 07-16 FLT/07-17 Softail/06-17 FXD
<b>12-574</b>	10G Billet Lifter Blocks, 99-17 Twin Cam
<b>03-634</b>	10G Pushrod Covers, 99-17 Twin Cam

#### MILWAUKEE-EIGHT® ALL BLACK

<b>03-985</b>	10G Cam Cover, 17-Up M8
<b>18-266</b>	10G Rocker Box Covers, 17-Up M8
<b>03-826</b>	10G Transmission Side Cover, Hydraulic 14-Up FLT
<b>03-864</b>	10G Transmission Top Cover, 17-Up M8
<b>12-584</b>	10G Billet Lifter Blocks, 17-Up M8
<b>03-636</b>	10G Pushrod Covers, 17-Up M8



Rocker Box Covers, M8



Rocker Box Covers, Twin Cam



Cam Cover, Twin Cam



Cam Cover, M8

Transmission Side Cover,  
HydraulicTransmission Side Cover,  
CableTransmission Top Cover,  
Twin CamTransmission Top Cover,  
M8Lifter Blocks,  
Twin CamLifter Blocks,  
M8

Pushrod Covers





DEEP CUT, BLACK



DEEP CUT, CHROME



10-GAUGE



DEEP CUT



10-GAUGE



DEEP CUT

## DEEP CUT PUSHROD COVERS

- ▶ Billet pushrods featuring Deep Cut style cuts that run the full length of the tube
- ▶ Machined from 6061-T6 billet aluminum
- ▶ Lower tubes allow easy access for adjustable pushrods
- ▶ Each kit consist of lower tubes, spring cups, top clips and all necessary seals
- ▶ Requires the use of the OEM inner tubes, springs and washers
- ▶ Available for 99-17 Twin Cam engines
- ▶ Available in chrome or black anodize finish

## TWIN CAM

03-630 Deep Cut, Chrome

03-631 Deep Cut, Black

## FRONT ENGINE MOUNTS & STABILIZER LINKS

- ▶ Front engine mounts and stabilizer links CNC machined from billet aluminum
- ▶ Front engine mount replaces factory stamped steel mount
- ▶ Engine stabilizer link features specially designed spherical bearings with a counterbore to result in a clean finish
- ▶ Both engine mount bracket & link will accept factory or aftermarket complementary components
- ▶ Mounting hardware
- ▶ Fitment: 08-16 FLT Touring models
- ▶ Sold individually

## ENGINE MOUNT, DEEP CUT

03-669 Deep Cut Engine Bracket, Chrome

03-670 Deep Cut Engine Bracket, Black

## ENGINE MOUNT, 10-GAUGE

03-667 10-Gauge Engine Bracket, Chrome

03-668 10-Gauge Engine Bracket, Black

## STABILIZER LINK, DEEP CUT

03-660 Deep Cut Stabilizer Link, Chrome

03-661 Deep Cut Stabilizer Link, Black

## STABILIZER LINK, 10-GAUGE

03-664 10-Gauge Stabilizer Link, Chrome

03-665 10-Gauge Stabilizer Link, Black

## OIL PRESSURE GAUGE KITS

- ▶ Enables you to constantly monitor your oil pressure to ensure maximum performance and long lasting reliability
- ▶ Features stainless housing and glass lens, filled with vibration dampening glycerin for lasting performance
- ▶ Billet bracket mounts oil pressure gauge to the rear Rocker Box
- ▶ Radius finished in Chrome, Black, or Deep Cut Black
- ▶ Complete kit includes: gauge, billet bracket/cone, stainless steel hose assembly and necessary hardware

### COMPLETE KIT

15-658	Radius Shield, Chrome, 99-17 Twin Cam
15-688	Radius Race Logo, Chrome, 99-17 Twin Cam
15-657	Radius Race Logo, Chrome, 84-99 EVO
15-668	Deep Cut Race Logo, Black, 99-17 Twin Cam
15-667	Deep Cut Race Logo, Black, 93-Up Sportster®
15-670	Deep Cut Race Logo, Black, 84-99 EVO
15-675	Radius Black Race Logo, 99-17 Twin Cam
15-676	Radius Race Logo, Black, 84-99 EVO

### ACCESSORIES

15-649	Replacement hose, Twin Cam
15-653	Repl. hose, 84-99 Big Twin / S&S EVO
15-646	Replacement hose, Sportster®
15-655	Replacement 1-1/2" gauge, Shield, 0-60 psi
15-665	Replacement Deep Cut gauge, Race Logo

**NOTE:** Does NOT work on Baggers with stock pressure gauge



RADIUS



DEEP CUT

## RE-USABLE BILLET OIL FILTERS

- ▶ Arlen Ness combines clean sculpted billet styling with high tech filter technology used in Formula 1, NASCAR, and the aerospace industry
- ▶ Oil filter element is made from laser cut 304 stainless steel and medical grade micronic cloth
- ▶ Catches items down to 35 microns, which is about three times better than most traditional oil filters
- ▶ Filters maintain consistent flow under all conditions, including extreme heat, presence of water, and cold startups
- ▶ Re-usable design, simple filter cleaning and service

### COMPLETE KIT

03-460	Deep Cut, Chrome
03-461	Deep Cut, Black
03-462	Beveled, Chrome
03-463	Beveled, Black

### REPLACEMENT PARTS

03-465	Replacement spring & oil ring set
03-466	Replacement filter



DEEP CUT



BEVELED



10-GAUGE  
All Black / Titanium



10-GAUGE  
Contrast / Chrome



15 SPOKE  
All Black / Chrome



DRIFT



BEVELED



DEEP CUT



SLOT TRACK

## BILLET HORN KITS

- ▶ Our horn assemblies are CNC machined from forged billet aluminum
- ▶ Stainless steel mesh offers style as well as function
- ▶ Our high performance horn is capable of 110 dB and makes sure you are heard when you need it most
- ▶ Offered in 2 different applications, each with its own specific mounting brackets: 91-Up Big Twin™/Universal Fitment & 91-Up XL

### 91-Up BIG TWIN/UNIVERSAL FITMENT

70-266	10-Gauge horn kit, All Black
70-267	10-Gauge horn kit, Titanium
70-250	10-Gauge horn kit, Contrast
70-251	10-Gauge horn kit, Chrome
70-260	15 Spoke horn kit, Black
70-261	15 Spoke horn kit, Chrome
70-252	Drift horn kit, Black
70-253	Drift horn kit, Chrome
70-204	Beveled horn kit, Black
70-205	Beveled horn kit, Chrome
70-201	Deep Cut horn kit, Black
70-200	Deep Cut horn kit, Chrome
70-202	Slot Track horn kit, Black

### 07-Up XL SPORTSTER™

70-258	10-Gauge horn kit, Contrast
70-259	10-Gauge horn kit, Chrome
70-262	15 Spoke horn kit, Black
70-263	15 Spoke horn kit, Chrome
70-256	Drift horn kit, Black
70-257	Drift horn kit, Chrome
70-218	Beveled horn kit, Black
70-219	Beveled horn kit, Chrome
70-214	Deep Cut horn kit, Chrome
70-215	Deep Cut horn kit, Black
70-216	Slot Track horn kit, Black

## HORN COVERS

- ▶ These round horn covers accept any 5 hole point cover to match the theme of your bike. Choose Ness, HD® or your favorite aftermarket design
- ▶ Steel construction cover is finished in chrome or black powder coated finish
- ▶ Replaces the factory "cowbell" shaped horn cover on 91- Up Big Twin™ and XL models
- ▶ Point cover sold separately

**03-590**     Horn cover, Chrome

**03-591**     Horn cover, Black



03-590 Chrome / 03-591 Black





BEVELED, LATCH COVER

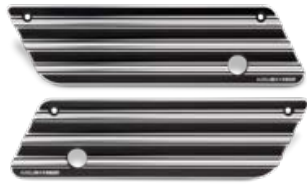

10-GAUGE, 93-13



DEEP CUT, 93-13



BEVELED, 93-13



SLOT TRACK, 93-13

### SADDLEBAG LATCH COVERS, 99-13 FLT

- ▶ CNC machined from billet aluminum
- ▶ Direct bolt-on design utilizes factory hinge and lock assemblies
- ▶ Mounting hardware included
- ▶ Sold in pairs
- ▶ Fitment: 99-13 FLT/FLHT/FLHR/FLTR/FLHX

93-13 FLT	CHROME	BLACK
10-Gauge	03-607	03-605
Deep Cut	03-529	03-554
Beveled	03-550	03-551
Slot Track	N/A	03-556



DEEP CUT, LATCH COVER

### SADDLEBAG LATCH COVERS, 14-Up FLT

- ▶ CNC machined from billet aluminum
- ▶ Direct bolt-on design utilizes factory hinge and lock assemblies
- ▶ Mounting hardware included
- ▶ Sold in pairs
- ▶ Fitment: 14-Up FLHT/FLHR/FLHX/FLTRX/FLTRU/FLTRK

14-Up FLT	CHROME	BLACK
10-Gauge	03-609	N/A
Deep Cut	03-536	03-546
Beveled	03-535	03-585



10-GAUGE, 14-Up



DEEP CUT, 14-Up



BEVELED, 14-Up

### BILLET SADDLEBAG LEVERS

- ▶ Forged billet aluminum levers replace factory 14-Up FLT saddlebag lid levers
- ▶ Each lever is first forged from aluminum then CNC machined to a perfect finish
- ▶ Simple bolt-on installation
- ▶ Available in Deep Cut, 10-Gauge or Beveled styles in black anodize or chrome finish
- ▶ Each style has matching saddlebag latch covers & many other accessories for every angle of your touring model
- ▶ Sold in pairs

14-Up FLT	CHROME	BLACK
10-Gauge	03-338	03-339
Deep Cut	03-334	03-335
Beveled	03-336	03-337



10-GAUGE



DEEP CUT



BEVELED





# LIGHTING & LICENSE

## SECTION CONTENT

- 129** Direct Bolt-On LED's
- 130** 1" Billet Bullets
- 131** Deep Cut Accessory Lights
- 132** Fire Ring LED's
- 133** License Plate Frames



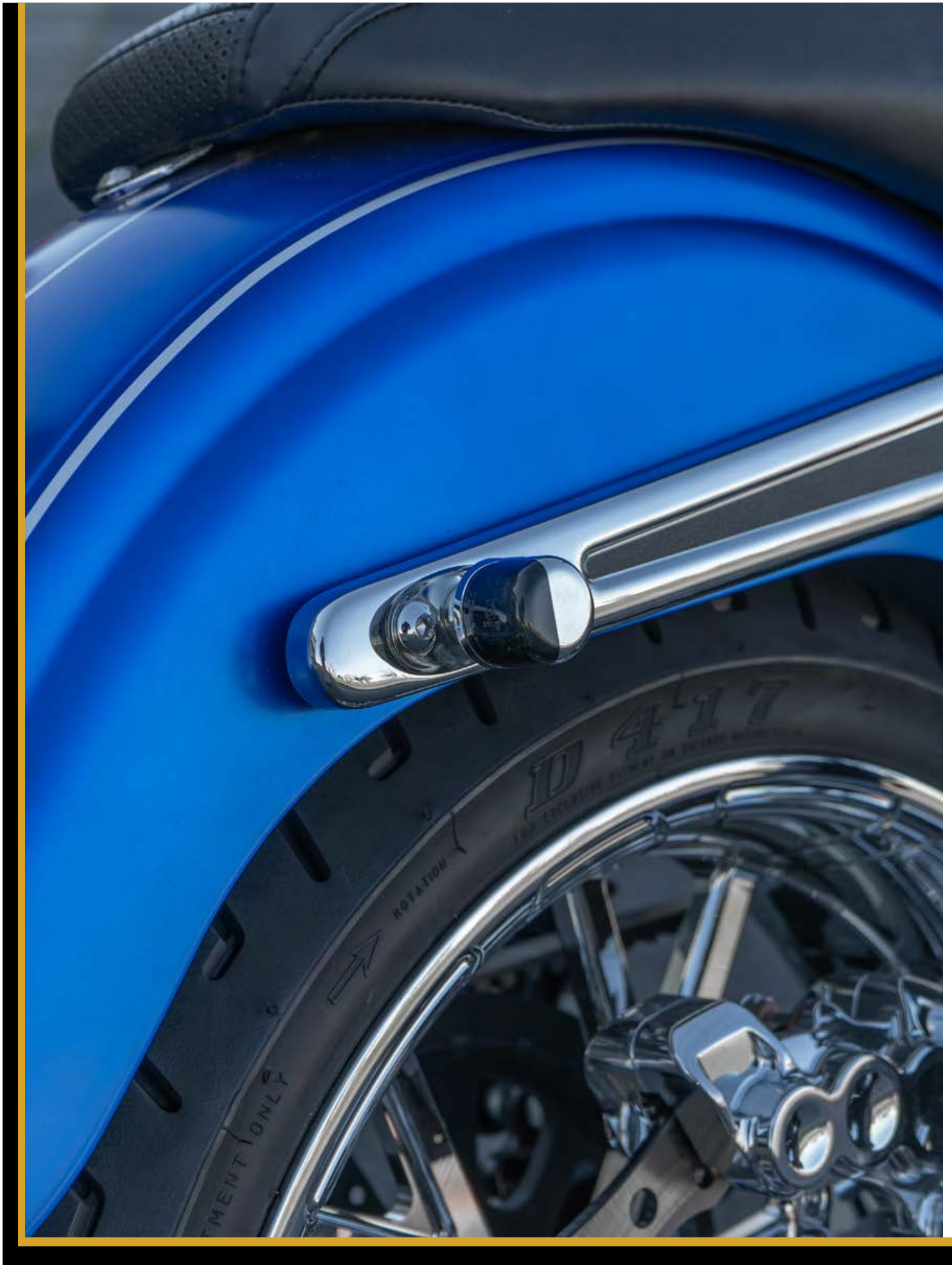

**DIRECT BOLT-ON ACCESSORY LIGHTS W/POWER LED**

- ▶ These are some of the cleanest and brightest direct bolt-on accessory lights you will ever find for your ride, no spacers or adapters necessary
- ▶ Our compact billet design flows nicely into your forks or fender struts to make them almost invisible. These lights contain two power LEDs that are equivalent to 25 traditional LEDs. The light produced from the Power LEDs is incredible.
- ▶ These lights are sold in pairs in chrome or black anodize finish

**FRONT**

**12-761** 06-Up FLHX/FLTR/FLTRX models & 04-Up FLT, Black w/ Amber LED

**REAR**

**12-740** 00-Up FXD/XL/FXST, Chrome w/Red LED

**12-741** 00-Up FXD/XL/FXST, Black w/Red LED

**12-743** 00-Up FXD/XL/FXST, Chrome w/Amber LED

**12-744** 00-Up FXD/XL/FXST, Black w/Amber LED

**NOTE:** These accessory lights are designed to be used as supplement lighting ONLY, not to replace original turn signals, marker, or brake lights.



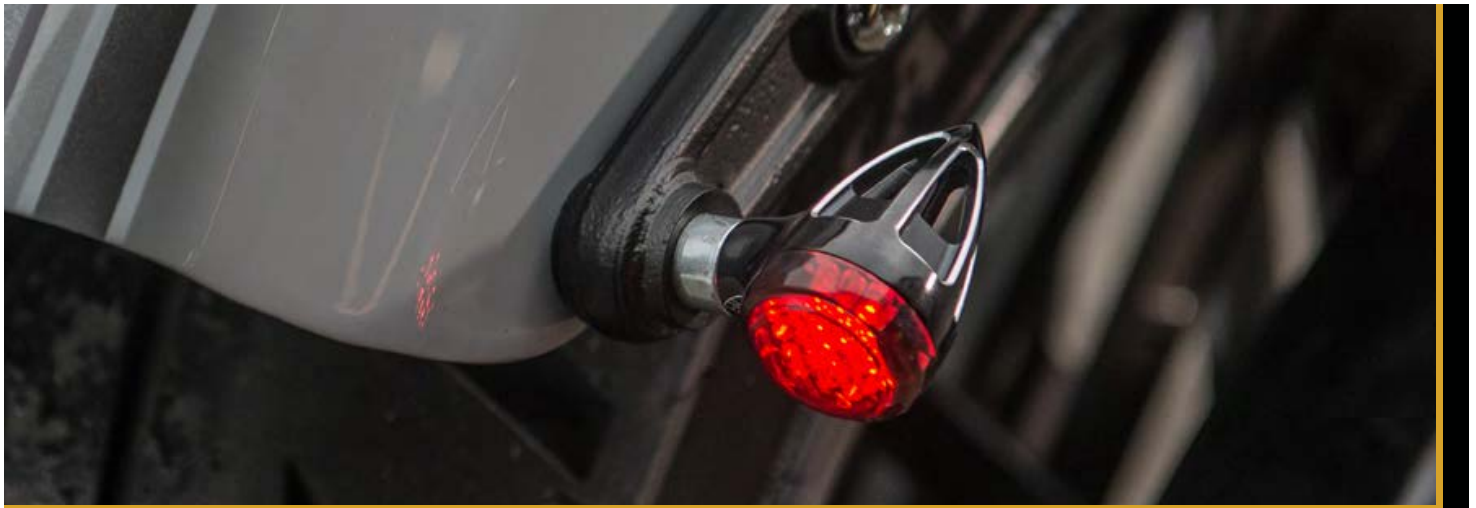

TEARDROP W/ RED LED



12-719

### 1" BILLET BULLET LED ACCESSORY LIGHTS

- ▶ Features 24 hi-intensity LED bulbs
- ▶ Accessory light housings are CNC machined from billet aluminum and feature a smoked lens for a clean look
- ▶ Teardrop design measures 1" diameter x 1-1/2" long
- ▶ Fluted design measures 1" diameter x 1-3/8" long
- ▶ Each light includes a 5/16"-24 threaded stud
- ▶ Dual filament
- ▶ Available in chrome or black anodize finish, sold in pairs

#### TEARDROP

##### CHROME

12-716 Teardrop w/ Amber LED

12-718 Teardrop w/ Red LED

##### BLACK

12-717 Teardrop w/ Amber LED

12-719 Teardrop w/ Red LED

#### FLUTED

##### CHROME

12-726 Fluted w/ Amber LED

12-728 Fluted w/ Red LED

##### BLACK

12-727 Fluted w/ Amber LED

12-729 Fluted w/ Red LED

**NOTE:** These accessory lights are designed to be used as supplement lighting ONLY, not to replace original turn signals, marker, or brake lights



Teardrop



Fluted

## DEEP CUT ACCESSORY LIGHTS

- ▶ CNC machined Deep Cut styled housing with our Fire Ring LED turn signal lighting
- ▶ Available in dual fitment for running and turn/brake function
- ▶ Our dual function LED design features a billet aluminum ring that is integrated into the lens.
- ▶ Each billet ring includes 7 exposed white or red LEDs to work as running lights.
- ▶ Behind the lens features a cluster LEDs for turn signal and/or brake functions. These fit all front and rear applications with a light socket for 1157 type bulb.
- ▶ Amber LEDs are required for front, red for rear applications
- ▶ Simple plug and play installation
- ▶ Available in chrome or black anodize finish
- ▶ Sold individually

	LENS	TRIM RING	TRIM LED	FILAMENT
12-753	Amber	Black	Amber	Dual
12-765	Amber	Black	White	Dual
12-750	Red	Chrome	Red	Dual
12-751	Red	Black	Red	Dual
12-767*	Amber	Black	Amber	Dual
12-769*	Amber	Black	White	Dual

\*Front fitment for FLTR/FLHX only

**NOTE:** For OEM functionality all front applications require dual filament kits and rear applications require single filament kits except 07-14 XL1200N & 09-14 XL883N models which require dual filament kits.

**NOTE:** Most multiple LED installations will require a load equalizer to insure proper flash rates and function of HD® security systems.

**NOTE:** These accessory lights are designed to be used as supplement lighting ONLY, not to replace original turn signals, marker, or brake lights.



12-764



12-764



## TURN SIGNAL MOUNTS FOR 39MM FORKS

- ▶ The perfect solution for relocating your turn signals off of your handlebars
- ▶ Fits Dyna®, FXR and Sportster® models
- ▶ Billet aluminum mounts bring your turn signals in close to your factory trees for a clean look
- ▶ No unsightly clamps, direct bolt-on to your triple tree pinch bolts
- ▶ Turn signal mounts can be mounted to upper or lower triple tree

### CHROME

**12-737** 87-Up XL; pre-06 Dyna® 87-96 FXR™ w/ 39mm forks

### BLACK

**12-738** 87-Up XL; pre-06 Dyna® 87-96 FXR™ w/ 39mm forks



12-737 Signal mounts for 39mm forks, installed



12-755



12-759

#### FIRE-RING LED's

- ▶ Upgrade your factory turn signals with LED's & CNC machined billet ring
- ▶ Available in dual fitment for running and turn/brake function
- ▶ Our dual function LED design features a billet aluminum ring that is integrated into the lens. Each billet ring includes 7 exposed white or red LED's to work as running light. Behind the lens features a cluster of LED's for turn signal and/or brake light functions.
- ▶ These fit all front and rear applications with a light socket for 1157 type bulb
- ▶ Amber LED's are required for front, red for rear applications
- ▶ Simple plug and play installation
- ▶ Black anodize finish
- ▶ Sold in pairs

	LENS	TRIM RING	TRIM LED	FILAMENT
12-757	Amber	Chrome	White	Dual
12-759	Amber	Black	White	Dual
12-755	Red	Black	Red	Dual

**NOTE:** Most multiple LED installations will require a load equalizer to insure proper flash rates and function of HD® security systems.

**NOTE:** For OEM functionality all front applications require dual filament kits and rear applications require single filament kits except 07-13 XL1200N & 09-13 XL883N models which require dual filament kits.



Fire Ring LED Accessory Light Kit



BEVELED, BLACK LICENSE FRAME

### LICENSE PLATE FRAMES

- ▶ Billet aluminum construction measures 7.25" x 4.25" to fit most states
- ▶ Blind hole mounting for a clean look
- ▶ Available in chrome or black anodize finish

### LICENSE FRAMES

12-135	10-Gauge, Chrome
12-136	10-Gauge, Black
12-134	Slot Track, Black
12-143	Beveled, Chrome
12-144	Beveled, Black
12-154	Deep Cut, Chrome
12-159	Deep Cut, Black
12-100	Ness Dealer, Black



10-Gauge, Chrome



10-Gauge, Black



Beveled, Chrome



Beveled, Black



Deep Cut, Chrome



Deep Cut, Black



Slot Track, Black



Ness Dealer, Black



Learn more about motorcycle parts on our website.