

GALFER

Racing

CATALOGUE
2019

PADS - DISCS - LINES

FONTANESI

HOLCOMBE x2

MARTIN

BOU x2

ONCU

REMES

CARRASCO

BRISTOW

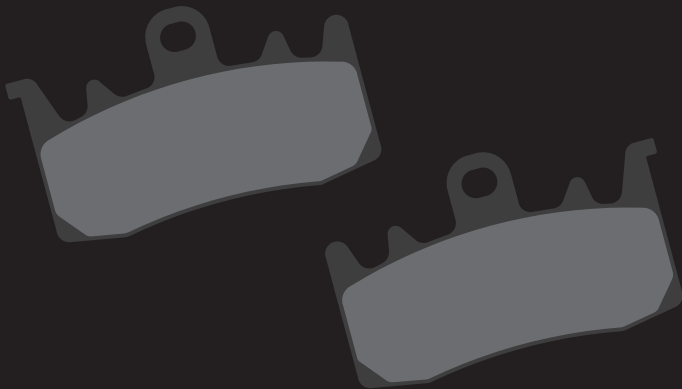

FOGGIA

HOLCOMBE

GARCÍA

BRISTOW

MIR

BOU

MASAKI

VERONA

GANDOLA

FONTANESI



BETTER BRAKE PADS COMPOUNDS FOR COMPETITION



COMPOUND G1300 (2.0)

Last generation sintered compound designed for competition: Great initial deceleration with a powerful start and a progressive final braking performance. Great for riders who like a strong braking at the start and a solid lever feel. It works on all temperatures and in all conditions. These brake pads are not particularly aggressive on brake discs and offer a reduced wear level. Use in MotoGP (no carbon discs), Moto 2, Moto 3, WSBK, Superstock 1000, Supersport, etc.

GP G1300 2.0

COMPOUND UPGRADED

DURABILITY DURABILIDAD	Km	<div style="width: 100%; height: 10px; background-color: yellow;"></div>
+°C PERFORMANCE RENDIMIENTO +°C	↑°C	<div style="width: 100%; height: 10px; background-color: yellow;"></div>
+°C PERFORMANCE RENDIMIENTO +°C	↓°C	<div style="width: 100%; height: 10px; background-color: yellow;"></div>
DRY SECO		<div style="width: 100%; height: 10px; background-color: yellow;"></div>
WET MOJADO		<div style="width: 100%; height: 10px; background-color: yellow;"></div>
FADE RESISTANCE RESISTENCIA FADE		<div style="width: 100%; height: 10px; background-color: yellow;"></div>
FEEL TACTO		<div style="width: 100%; height: 10px; background-color: yellow;"></div>

125cc Pre-Moto3

Front Rear

Moto3

Front Rear

SSPP Moto2

Front Rear

SBK MotoGP

Front Rear

SINTERED G1371

DURABILITY DURABILIDAD	Km	<div style="width: 100%; height: 10px; background-color: yellow;"></div>
+°C PERFORMANCE RENDIMIENTO +°C	↑°C	<div style="width: 100%; height: 10px; background-color: yellow;"></div>
+°C PERFORMANCE RENDIMIENTO +°C	↓°C	<div style="width: 100%; height: 10px; background-color: yellow;"></div>
DRY SECO		<div style="width: 100%; height: 10px; background-color: yellow;"></div>
WET MOJADO		<div style="width: 100%; height: 10px; background-color: yellow;"></div>
FADE RESISTANCE RESISTENCIA FADE		<div style="width: 100%; height: 10px; background-color: yellow;"></div>
FEEL TACTO		<div style="width: 100%; height: 10px; background-color: yellow;"></div>

125cc Pre-Moto3

Front Rear

Moto3

Front Rear

SSPP Moto2

Front Rear

SBK MotoGP

Front Rear



WHY DISC WAVE DESIGN?



✓ **-15% WEIGHT REDUCTION**

✓ **BETTER COOLING**

✓ **MORE BRAKING POWER**

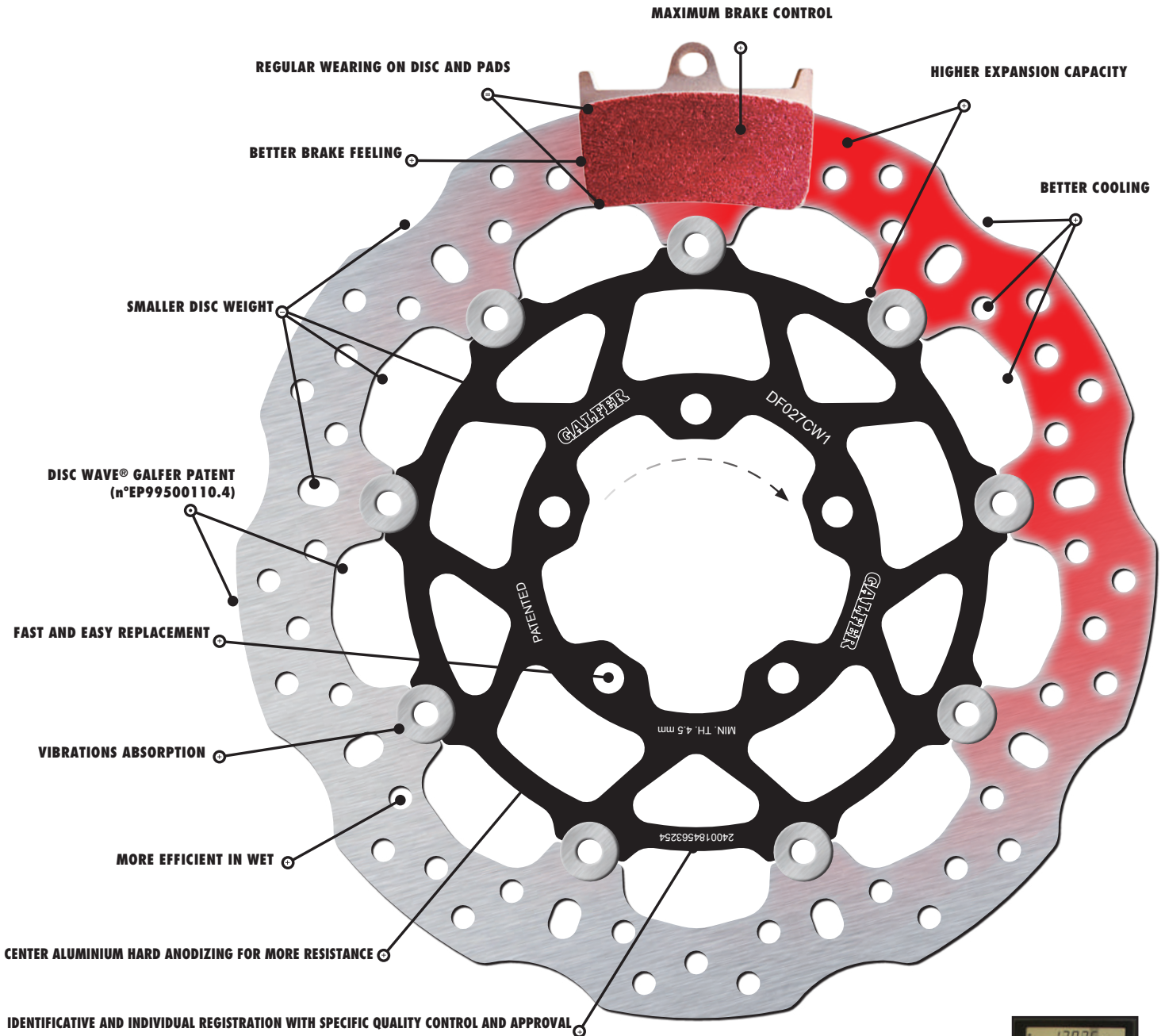

DISC WAVE® GALFER

CONSTANT POWER AND FEELING

Regular wearing on disc and pads

Double wave perimeter, homogeneous pressure in the surface of the pads

GALFER PATENT N° E P 99500110.4

WAVE FAKE IMITATIONS

LOSS OF POWER AND FEELING

Irregular wearing on disc and pads

Outside wave perimeter and inside circular perimeter



DISC REFERENCE	Ø ext	th.	Offset	Ø int	Ø ee	n° holes	Ø hole	Hole	Weight gr.	Category	Position	Brand
DF019W	187	4,0	88	88	110	3	10,5 x 12,5	Coliso	319	MOTO 3 / PRE	REAR	HONDA
DF023WMU	170	3,0	3	64	84	3	8,5		223	PRE MOTO 3	REAR	RMU
DF027CW1	296	4,5	17	58	74	6	6,5		1250	MOTO 3	FRONT	HONDA
DF027CEW1	296	5,2	17	58	74	6	6,5		1152	PRE-MOTO3	FRONT	HONDA (Brembo)
DF033CW1	290	4,5	17	58	74	6	6,5		1023	MOTO 3 / PRE	FRONT	HONDA
DF043W	186	3,4	3,4	88	110	3	10,5 x 12,5	Fresado	300	MOTO 3 / PRE	REAR	HONDA
DF044CW1	290	5,5	15	61	74	6	6,5		1210	MOTO 3	FRONT	KTM
DF045W	190	4,5	4,5	70	92	3	10,5	Fresado	467	MOTO 3	REAR	KTM
DF070CW1	310	5,0	12,5	94	110	6	6,5		1260	SSP	FRONT	HONDA
DF076CW1	320	5,5	15,25	94	110	6	6,5		1490	SBK	FRONT	HONDA
DF091CW1	320	5,0	15,25	74	90	6	6,5		1500	SBK	FRONT	HONDA
DF095CW1	296	4,5	4,5	60	80	6	8,5		1100	85cc	FRONT	BEON
DF096FLW1	195	3,5	3,5	88	110	3	10,3		615	85cc	REAR	BEON
DF100CW1	218	4,0	8	60	80	3	8,5		580	MOTO 3	FRONT	HONDA
DF101CW1	190	4,0	5	70	92	3	10,3	Fresado	420	MOTO 3	REAR	HONDA
DF102CW1	218	4,0	8	60,1	80	3	9,9	Fresado	580	MOTO 3	FRONT	KTM
DF103W1	187	3,5	88	88	110	3	10,5 x 12,5	Coliso	260	MOTO 3	REAR	MAHINDRA
DF104CW1	218	4,0	6	60	80	6	8,5	Fresado	580	MOTO 3	FRONT	TM RACING
DF105CW1	190	4,0	5	70	92	3	8,5	Fresado	420	MOTO 3	REAR	TM RACING
DF110CW1	290	60		12,5	80	6	8,3		1154	MOTO 2	FRONT	KALEX/SUTER
DF111CW1	217,75	4,5	10,25	69	86	3	8,3		680	MOTO 2	REAR	KALEX (14-18)
DF112CW1	310	5,5	17	69	86	6	8,3		1160	MOTO 2	FRONT	TECH 3
DF113CW1	217,75	4,0	10	70	90	3	8,3		550	MOTO 2	REAR	SUTER
DF114CW1	217,75	4,5	10,25	69	86	3	8,3		780	MOTO 2	REAR	KALEX (19-)
DF184CW1	300	5,8	80	80	100	5	10,5		1503	SSP	FRONT	KAWASAKI
DF193WAR	220	4,0	5	100	120	4	10,5		495	SSP / SBK	REAR	KAWASAKI
DF194CW1	330	5,8	5	80	100	5	10,5		1743	SBK	FRONT	KAWASAKI 2016
DF211CW1	330	5,8	12,4	70	90	5	10,6		1700	SBK	FRONT	KAWASAKI 2017
DF325CW1	320	5,0	5	102	120	6	8,2		1358	SBK	FRONT	SUZUKI 2016
DF348CW1	310	5,0	5	100	120	5	10,5		1250	SSP	FRONT	SUZUKI
DF358CW1	310	5,0	5	102	120	6	10,5		1275	SSP	FRONT	SUZUKI
DF358CW2	310	5,0	5	102	120	6	10,5		1425	SSP	FRONT	SUZUKI
DF370W	220	5,0	5	110	131	5	10,5	Fresado	662	SBK	REAR	SUZUKI 2016
DF475CW1	320	5,5	5,5	132	150	5	8,5		1419	SBK	FRONT	YAMAHA
DF482CW1	310	5,0	132	132	150	5	10,5		1200	SSP	FRONT	YAMAHA
DF755CW1	320	6,0	5	179	203	5	8,5		1410	SBK	FRONT	BMW
DF756W	220	5,0	5	119,5	135	5	6,6		615	SBK	REAR	BMW
DF817CW1	320	5,5	5	64	80	6	8,5		1450	SBK	FRONT	BMW
DF830CW1	320	5,0	5	80	102	5	8,5	Fresado	1380	SSP	FRONT	MV AUGUSTA
DF883CW2	320	5,5	10	64	80	6	8,5		1579	SBK	FRONT	APRILIA 2016
DF906CW1	310	5,0	5,0	83	100,5	5	10,5		1350	SSP	FRONT	TRIUMPH
DF952CW1	330	5,5	10,25	64	80	6	8,5		1477	SBK	FRONT	APRILIA 2017

Sizes in millimeters (mm)

CATEGORY	BRAND & MODEL	YEAR MODEL	FRONT			REAR	
			PADS (FD)	No.DF	DISCS (DF)	PADS (FD)	DISCS (DF)
85cc	BEON	17-		1	DF095CW1		DF096FLW1
PRE MOTO3	RMU	13-	FDP14002G1038	1	DF027CEW1/CW1A	FD224G1054	DF023W00MU
	BEON	13-	FD262G1300	1	DF027CEW1/CW1A	FD224G1054	DF043W
	MORIWAKI	13-	FD331G1300	1	DF027CEW1/CW1A	FD224G1054	DF019W
	HONDA NSF 250 R (1 disc front - OE caliper)	12-	FD331G1300	1	DF027CW1	FD113G1054	DF019W
MOTO3	HONDA NSF 250 R (1 disc front - Brembo caliper)	12-	FD168G1300	1	DF027CEW1	FD113G1054	DF019W
	KTM (1 disc front)	13-	FD168G1300	1	DF044CW1	FD441G1396	DF045W
	HONDA SUTER (2 discs front)	13-	FD391G1300	2	DF100CW1	FD181G1054	DF101CW1
	KTM (2 discs front)	13-	FD391G1300	2	DF102CW1	FD181G1054	DF101CW1
	MAHINDRA	13-	consult	2	DF100CW1	consult	DF103W1
	TM RACING	17-	consult	2	DF104CW1	consult	DF105CW1
	SUPERSPORT 300	YAMAHA R-3	15-	FD485G1300	1	DF460CW1	FD484G1370
KAWASAKI NINJA 300R		13-	FD117G1330	1	DF205CW1	FD117G1370	DF206W
KAWASAKI NINJA 400		18-	FD532G1310	1	DF214CW1	FD532G1310	DF213WF1
KTM 390 DUKE		14-	FD450G1375	1	DF800CW	FD165G1371	DF790W
HONDA CBR 500R		13-	FD266G1375	1	DF080W	FD103G1371	DF081W
MOTO2	KALEX	14-18	FD478G1300	2	DF110CW1	consult	DF111CW1
	KALEX	19-	FD478G1300	2	DF110CW1	consult	DF114CW1
	SUTER	14-	FD478G1300	2	DF110CW1	consult	DF113CW1
	MISTRAL 610 (TECH3)	14-	FD478G1300	2	DF112CW1	FD181G1054	consult
SUPERSPORT 600	YAMAHA R-6	05-16	FD178G1300	2	DF482CW1	FD134G1371	DF496W
	YAMAHA R-6	17-	FD178G1300	2	DF475CW1	FD134G1371	DF496W
	HONDA CBR 600 RR	07-	FD326G1300	2	DF070CW1	FD363G1371	DF013W
	KAWASAKI ZX6R	05-	FD371G1300	2	DF184CW1	FD167G1371	DF193W
	SUZUKI GSXR 600R	08-	FD325G1300	2	DF358CW1/2	FD363G1371	DF339W
	MV AUGUSTA F3 / BRUTALE (675/800cc)	11-	FD176G1300	2	DF830CW1	FD220G1371	DF831W
	TRIUMPH DAYTONA 675 R	13-	FD373G1300	2	DF906CW1	FD103G1371	DF907W
SUPERBIKE	KAWASAKI ZX10R	16	FD373G1300	2	DF194CW1	FD363G1371	DF193WAR
	KAWASAKI ZX10R	17-	FD373G1300	2	DF211CW1	FD363G1371	DF193WAR
	HONDA CBR 1000 RR SP	13-16	FD373G1300	2	DF076CW1	FD363G1371	DF013W
	HONDA CBR 1000 RR SP	17-	FD373G1300	2	DF091CW1	FD363G1371	DF013W
	BMW HP4	12-	FD373G1300	2	DF817CW1	FD165G1371	DF756W
	BMW S 1000 RR	09-	FD437G1300	2	DF755CW1	FD165G1371	DF756W
	SUZUKI GSX R 1000	12-15	FD373G1300	2	DF358CW1/2	FD363G1371	DF339W
	SUZUKI GSX R 1000	16-	FD373G1300	2	DF325CW1	FD363G1371	DF370W
	YAMAHA YZF R-1 / R-1 M	15-	FD178G1300	2	DF475CW1	FD363G1371	DF496W
	APRILIA RSV4 RR	15-16	FD373G1300	2	DF883CW2	FD220G1371	DF669W
	APRILIA RSV4 RR	17-	FD373G1300	2	DF952CW1	FD220G1371	DF669WA
	DUCATI PANIGALE	15-	FD373G1300	2	DF774CW1	FD220G1371	DF775W/DF839W



DO NOT USE DIFFERENT BRAKE PADS AS RECOMMENDED IN THIS CATALOG FOR GALFER BRAKE DISC.

GALFER
FD
068
G1300

↔ 69,6
mm x
↓ 51,0
⏏ 8,2

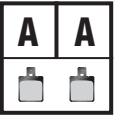
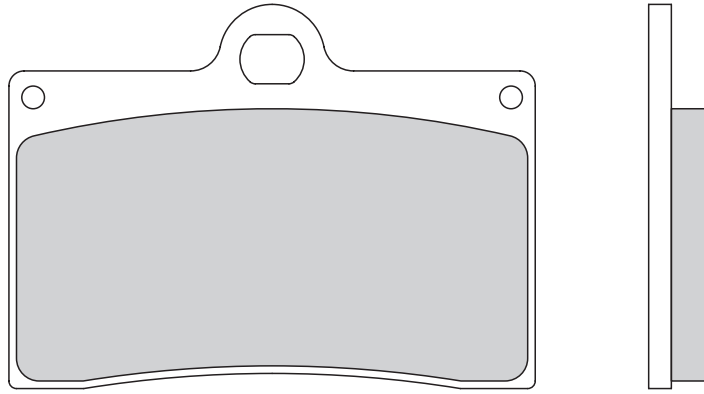

GALFER
FD
103
G1371

↔ 86,0
mm x
↓ 40,2
⏏ 10,6

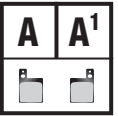
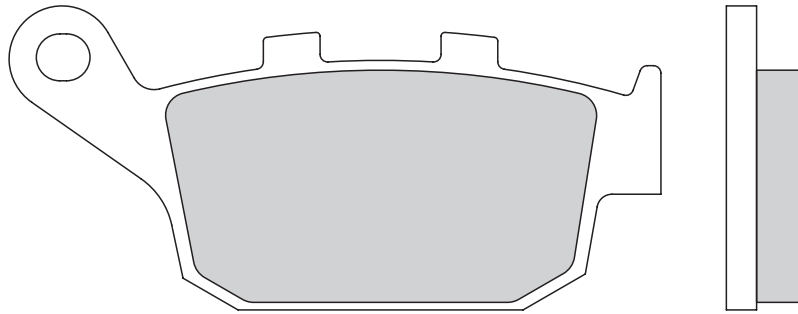

FD457 (th. 9,0mm) can replace FD103 (not vice versa) | FD457 (th. 9,0mm) puede sustituir FD103 (no al revés)

GALFER
FD
113
G1054

↔ 52,0
mm x
↓ 36,6
⏏ 8,3

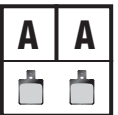
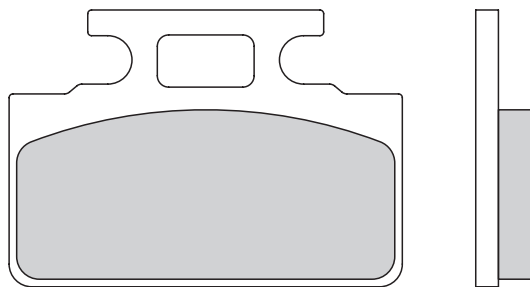

GALFER
FD
117
G1370
G1300

↔ 77,4
mm x
↓ 42,3
⏏ 7,7

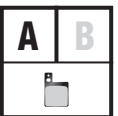
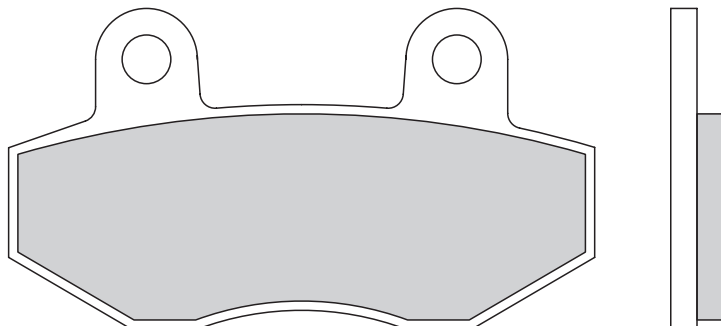

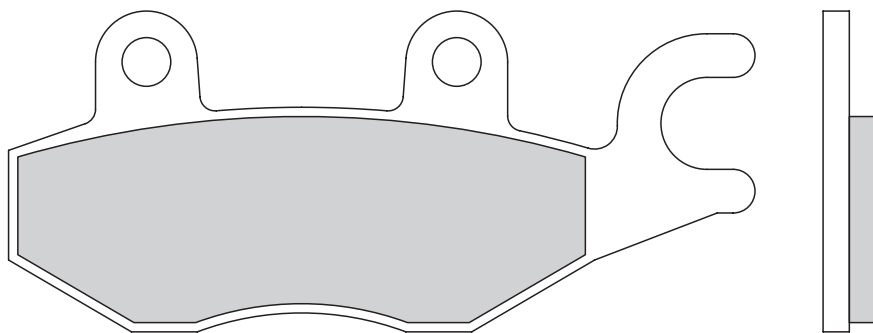
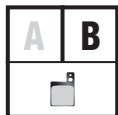

\longleftrightarrow	98,8
mm	x
\updownarrow	42,4
$\blacktriangleleft\blacktriangleright$	7,5

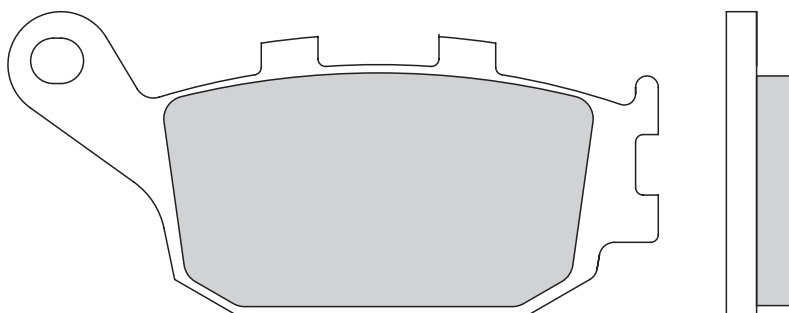
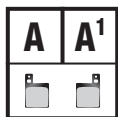

GALFER
FD
134
G1371

\longleftrightarrow	86,0
mm	x
\updownarrow	36,7
$\blacktriangleleft\blacktriangleright$	9,0

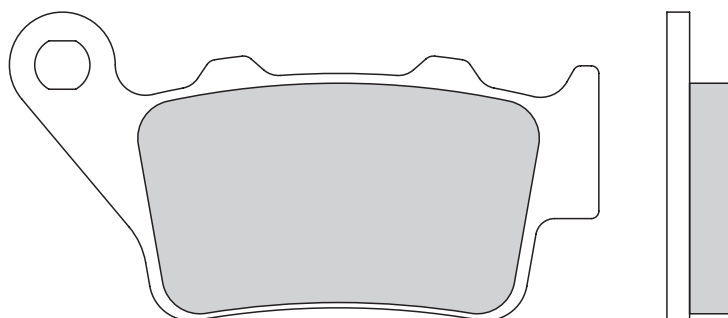
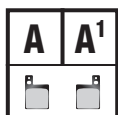

GALFER
FD
165
G1371

\longleftrightarrow	78,0
mm	x
\updownarrow	40,8
$\blacktriangleleft\blacktriangleright$	9,0

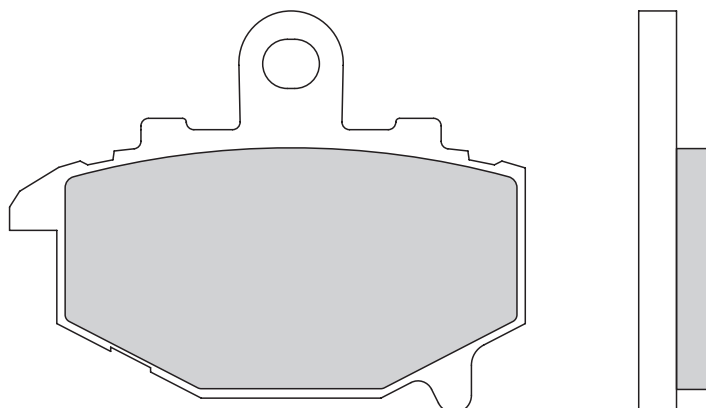
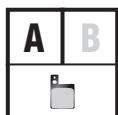

GALFER
FD
167
G1371

\longleftrightarrow	68,2
mm	x
\updownarrow	53,1
$\blacktriangleleft\blacktriangleright$	9,8

89,4
 mm x
 51,2
 8,8

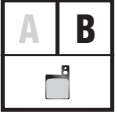
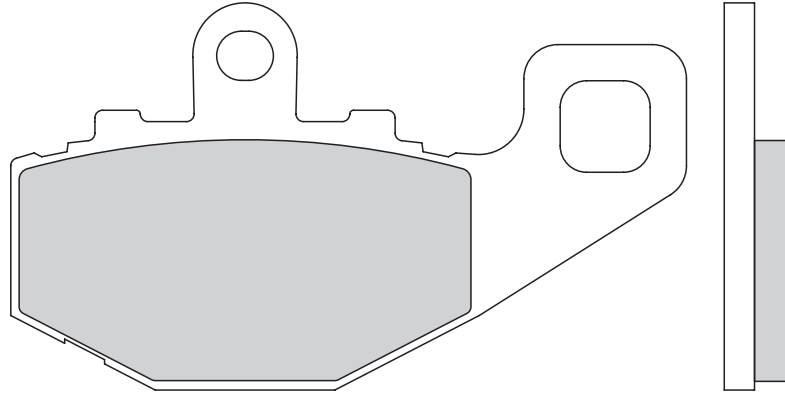

GALFER
FD
168
G1300

77,4
 mm x
 42,8
 8,4

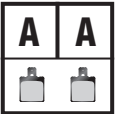
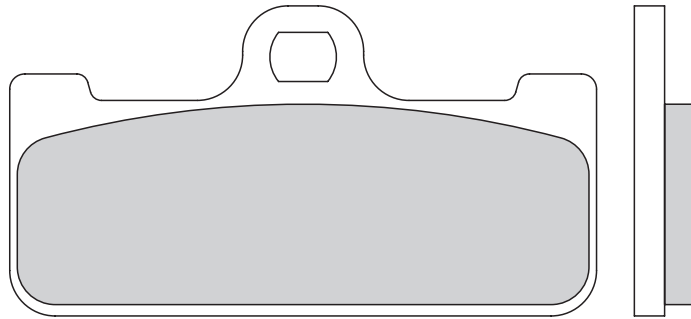

GALFER
FD
176
G1300

75,0
 mm x
 55,5
 8,7

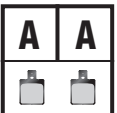
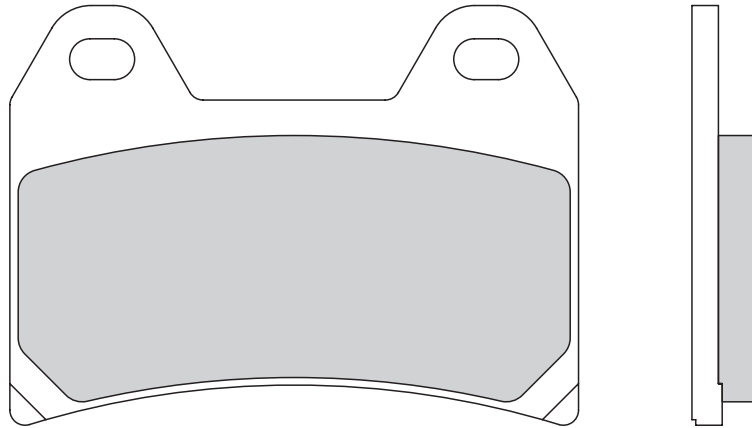

GALFER
FD
178
G1300

69,0
 mm x
 50,6
 8,8

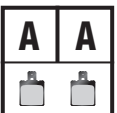
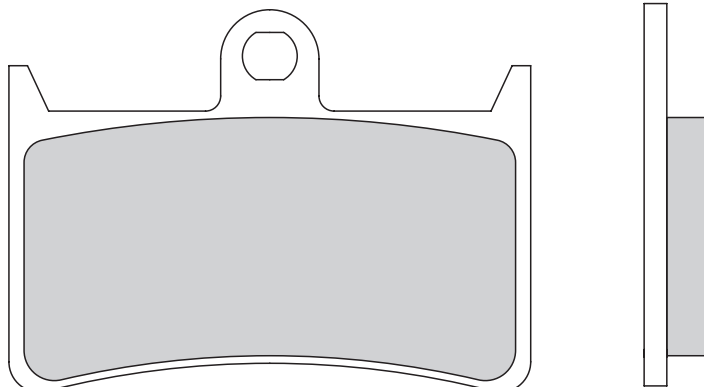

FD068 (th. 8,2mm) replace FD178 (not vice versa) | FD068 (th. 8,2mm) sustituye a FD178 (no al revés)

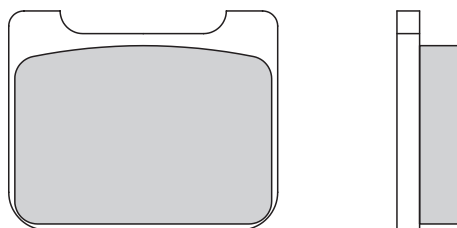
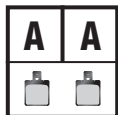

GALFER
FD
181
G1054

↔ 35,6
mm x
↑ 29,0

↔ 8,3

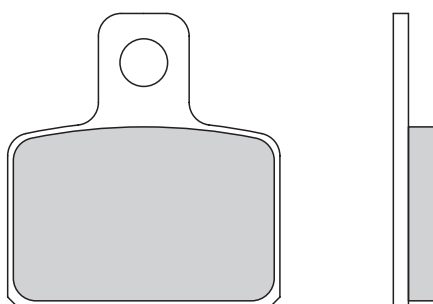
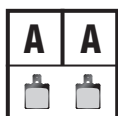

GALFER
FD
224
G1054

↔ 36,0
mm x
↑ 39,0

↔ 6,0

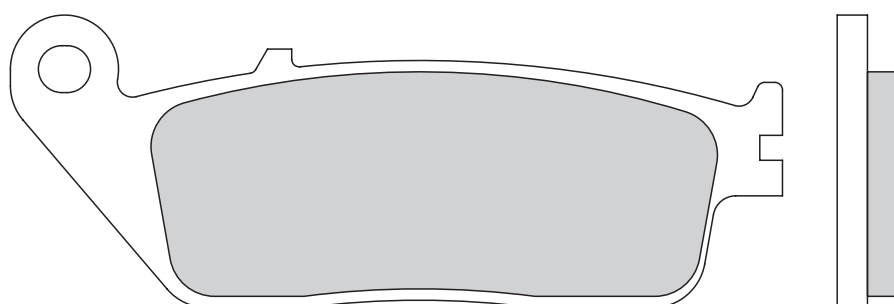
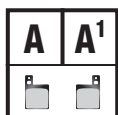

GALFER
FD
266
G1375

↔ 102,1
mm x
↑ 38,7

↔ 8,3

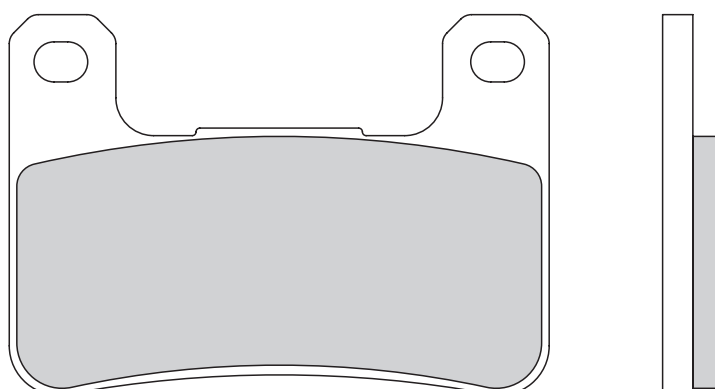
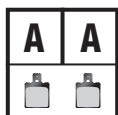

GALFER
FD
325
G1300

↔ 71,4
mm x
↑ 50,0

↔ 8,0

GALFER
FD
326
G1300

↔ 74,3
mm x
↓ 47,1
↔ 7,9

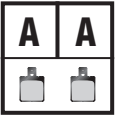
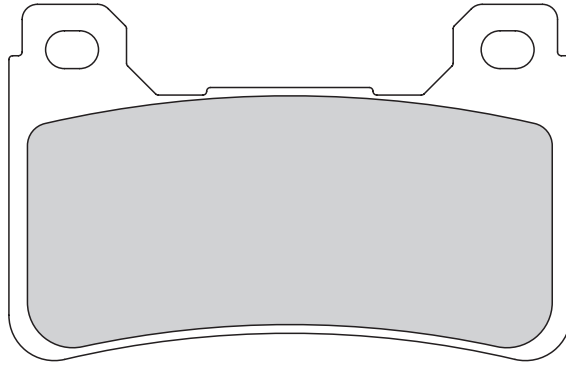

GALFER
FD
331
G1300

↔ 69,5
mm x
↓ 49,6
↔ 7,0

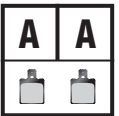
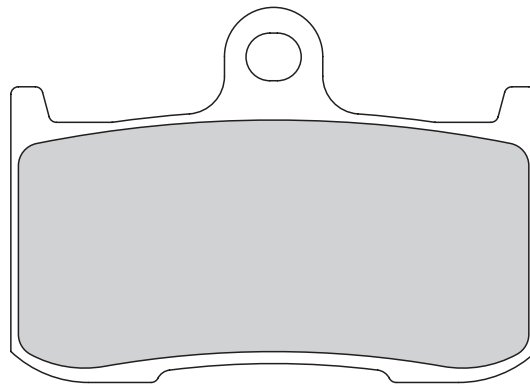

GALFER
FD
341

↔ 69,9
mm x
↓ 51,6
↔ 7,5

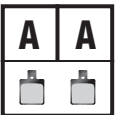
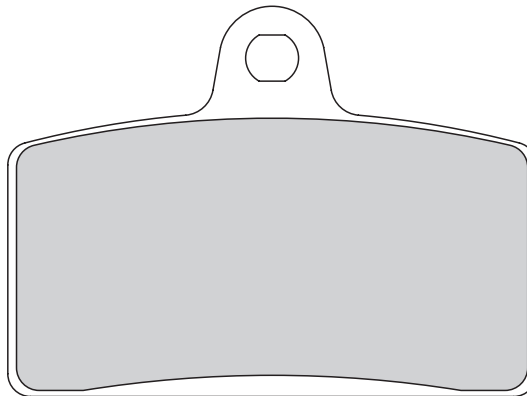

GALFER
FD
363
G1371

↔ 77,5
mm x
↓ 42,1
↔ 10,4

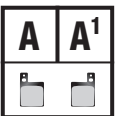
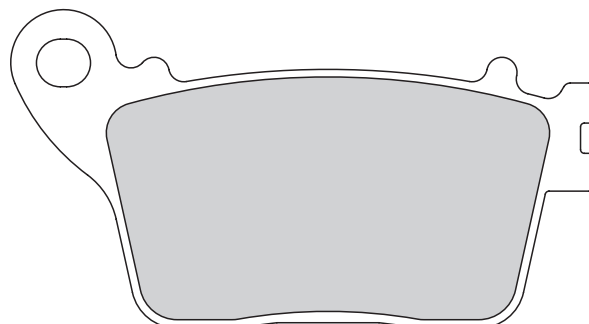

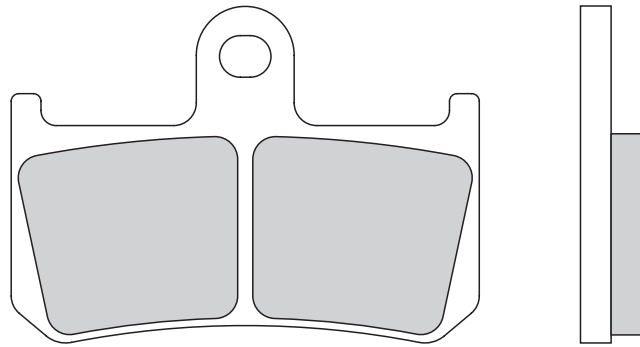
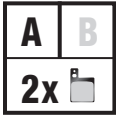

GALFER
FD
365
G1300

↔ 30,9
mm x
↑ 48,0

↔ 8,5

↔ 61,9
mm x
↑ 44,8

↔ 8,5

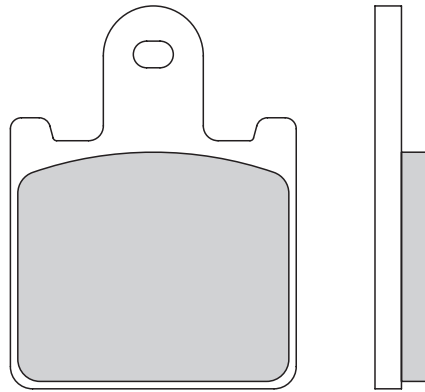
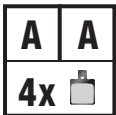
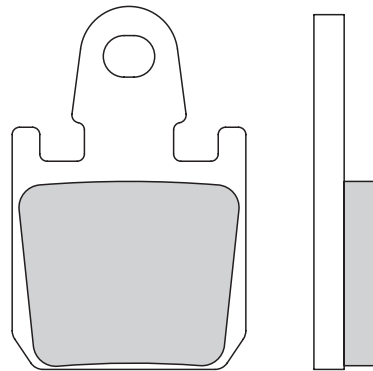
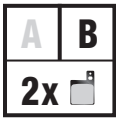

GALFER
FD
371
G1300

↔ 37,7
mm x
↑ 49,9

↔ 7,8

FD290 (th. 9,0mm) can replace FD371 but without mounting springs (not vice versa)

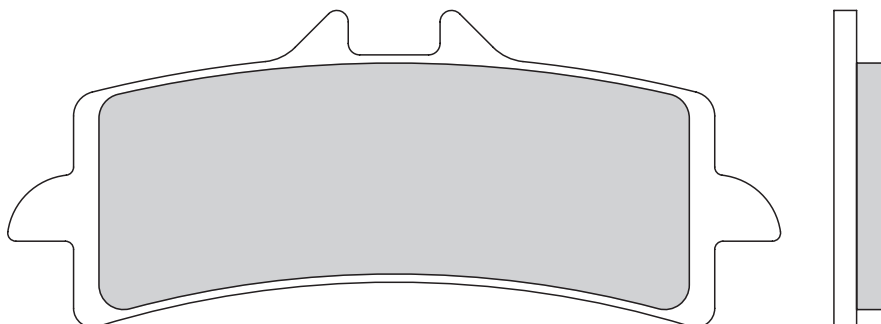
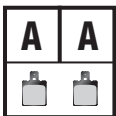

GALFER
FD
373
G1300

↔ 102,2
mm x
↑ 41,9

↔ 7,5

GALFER
FD
391
G1300

↔ 43,2
mm x
↓ 48,7
↔ 10,0

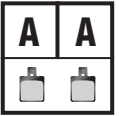
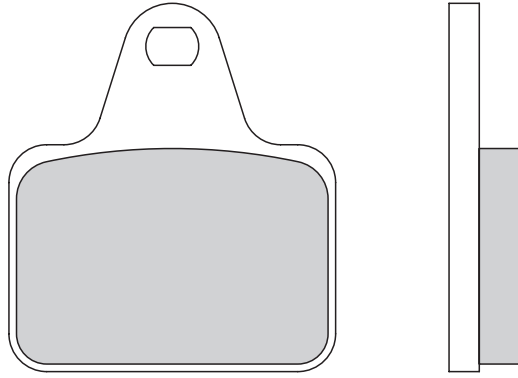

GALFER
FD
437
G1300

↔ 35,0
mm x
↓ 40,5
↔ 9,0

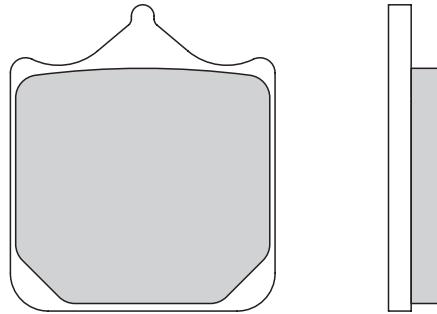

GALFER
FD
450
G1375

↔ 69,5
mm x
↓ 45,2
↔ 8,8

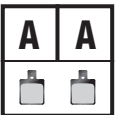
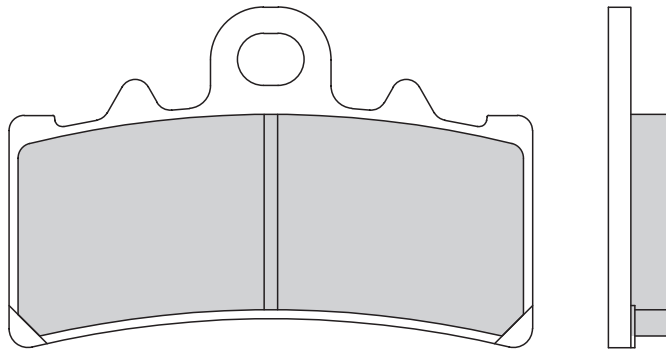

GALFER
FD
475
G1300

↔ 84,9
mm x
↓ 51,3
↔ 8,0

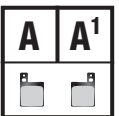
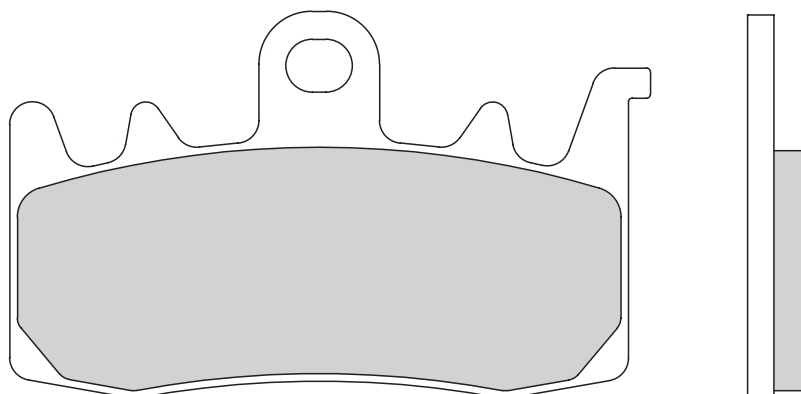

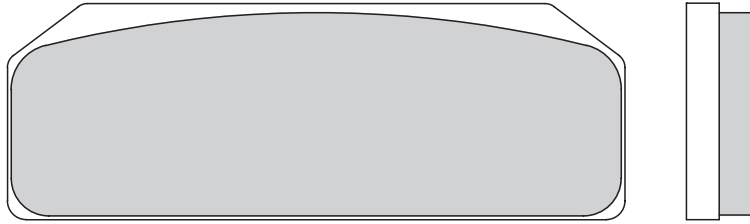
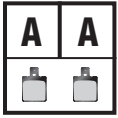

GALFER
FD
478
G1300

↔ 82,0
mm x
↑ 28,7
↔ 9,5

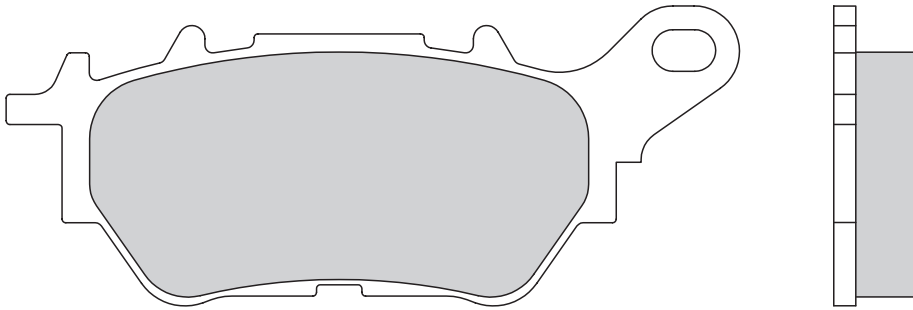
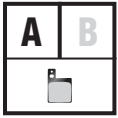

GALFER
FD
484
G1370

↔ 97,0
mm x
↑ 39,7
↔ 11,5

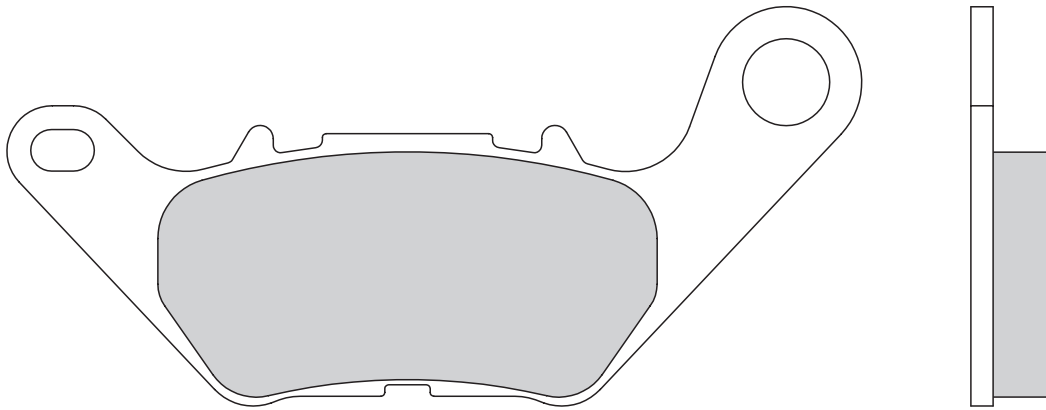
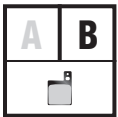

↔ 113,0
mm x
↑ 52,8
↔ 11,5

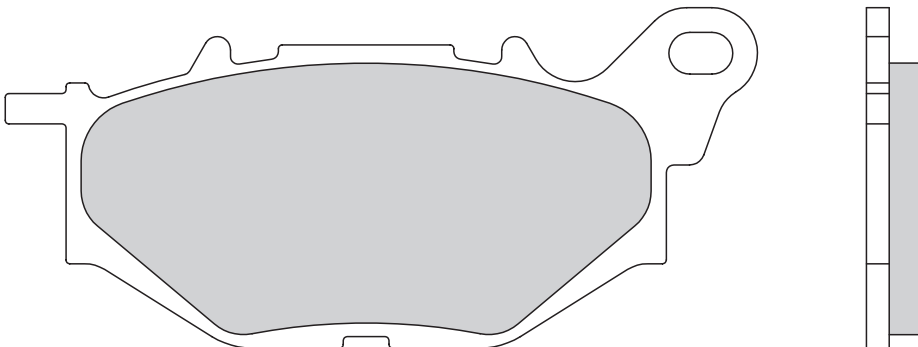
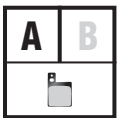

GALFER
FD
485
G1300

↔ 99,0
mm x
↑ 44,8
↔ 8,5

↔	113,3
mm	x
↕	54,9
⏏	8,5

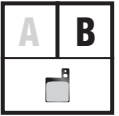
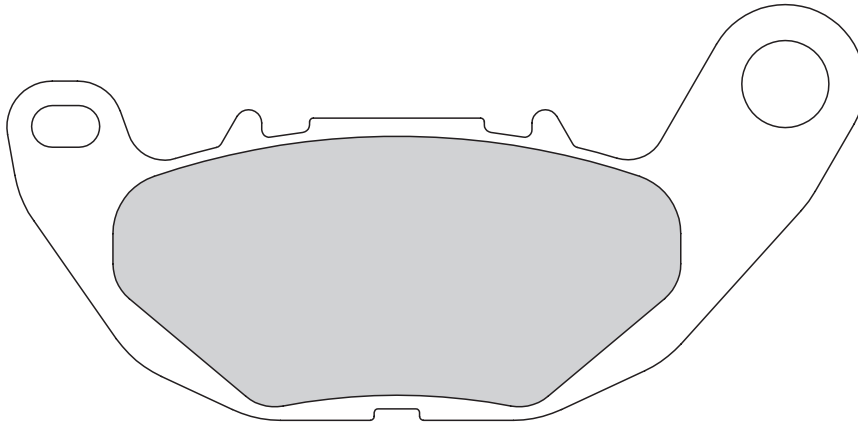

GALFER
FD
507
G1300

↔	69,5
mm	x
↕	46,7
⏏	8,2

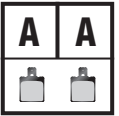
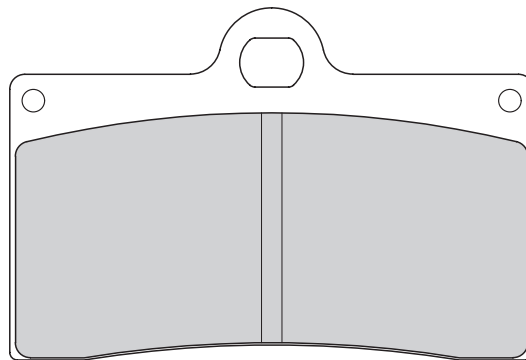





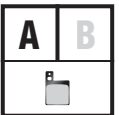
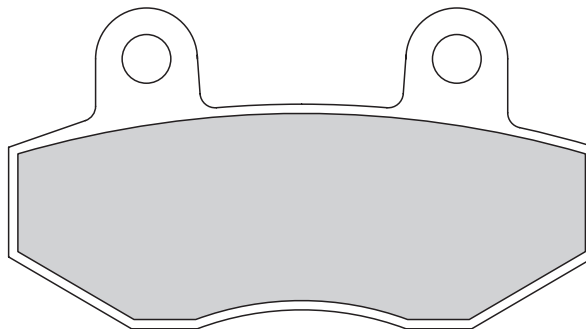



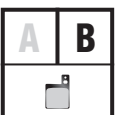
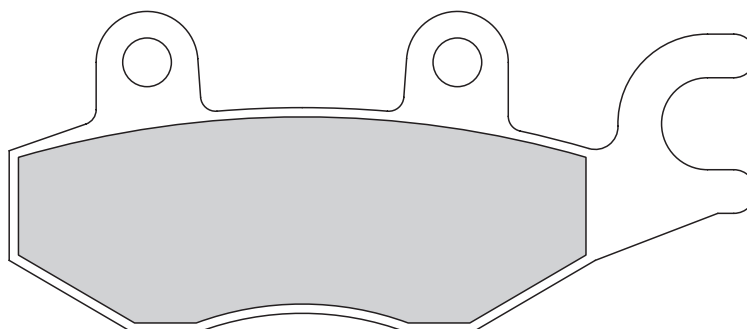

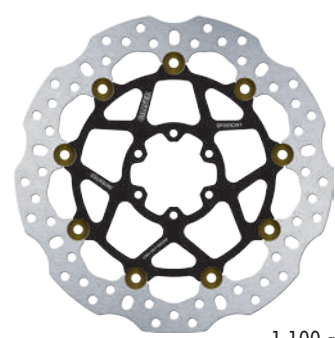
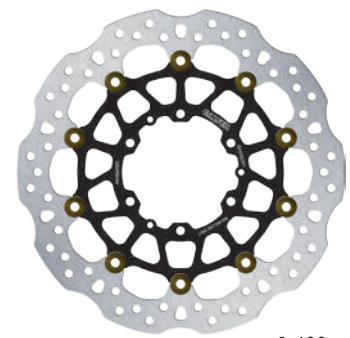

GALFER
FD
532
G1310

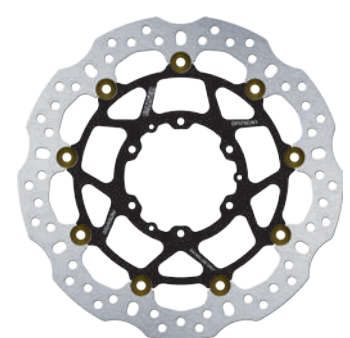
↔	77,4
mm	x
↕	42,3
⏏	8,4

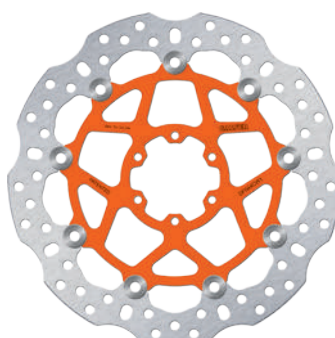

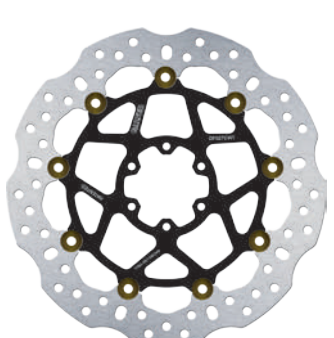

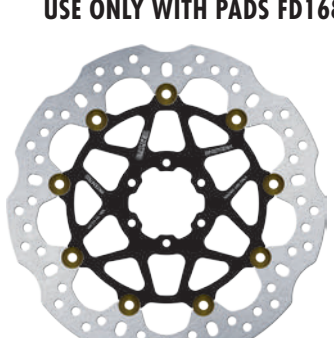

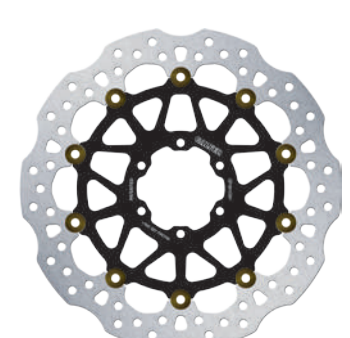
↔	96,8
mm	x
↕	42,3
⏏	8,5



<p>GALFER DF 013 W</p> <p>øext. 220 mm øint. 105</p> <p>4,5</p> <p>17,0</p>	 <p>678 gr</p>	<p>GALFER DF 033 CW1</p> <p>øext. 290 mm øint. 58</p> <p>4,5</p> <p>17,0</p>	 <p>1.100 gr</p>	<p>GALFER DF 070 CW1</p> <p>øext. 310 mm øint. 94</p> <p>5,0</p> <p>12,5</p>	 <p>1.400 gr</p>
<p>GALFER DF 019 W</p> <p>øext. 187 mm øint. 88</p> <p>4,0</p> <p>15,25</p>	 <p>319 gr</p>	<p>GALFER DF 043 W</p> <p>øext. 186 mm øint. 88</p> <p>3,4</p> <p>15,25</p>	 <p>300 gr</p>	<p>GALFER DF 076 CW1</p> <p>øext. 320 mm øint. 94</p> <p>5,5</p> <p>15,25</p>	 <p>1.490 gr</p>
<p>GALFER DF 023 W00MU</p> <p>øext. 170 mm øint. 64</p> <p>3,0</p> <p>15</p>	 <p>223 gr</p>	<p>GALFER DF 044 CW1</p> <p>øext. 290 mm øint. 61</p> <p>5,5</p> <p>15</p>	 <p>1.210 gr</p>	<p>GALFER DF 080 W</p> <p>øext. 320 mm øint. 211</p> <p>5,0</p> <p>15,25</p>	 <p>1.130 gr</p>
<p>GALFER DF 027 CW1</p> <p>øext. 296 mm øint. 58</p> <p>4,5</p> <p>17,0</p>	 <p>1.250 gr</p>	<p>GALFER DF 045 W</p> <p>øext. 190 mm øint. 70</p> <p>4,5</p> <p>15,25</p>	 <p>476 gr</p>	<p>GALFER DF 081 W</p> <p>øext. 240 mm øint. 116,5</p> <p>5,0</p> <p>15,25</p>	 <p>780 gr</p>
<p>GALFER DF 027 CEW1</p> <p>øext. 296 mm øint. 58</p> <p>5,2</p> <p>17,0</p>	<p>USE ONLY WITH PADS FD168</p>  <p>1.152 gr</p>	<p>GALFER DF 048 W</p> <p>øext. 220 mm øint. 105</p> <p>4,2</p> <p>15,25</p>	 <p>477 gr</p>	<p>GALFER DF 091 CW1</p> <p>øext. 320 mm øint. 74</p> <p>5,0</p> <p>15,25</p>	 <p>1.500 gr</p>



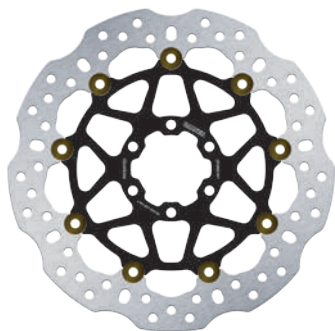

GALFER
DF
095
CW1

 \varnothing ext.	296 mm
 \varnothing int.	60
	4,5
	6,0



1.100 gr



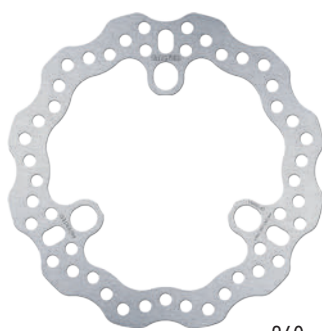

GALFER
DF
103
W1

 \varnothing ext.	187 mm
 \varnothing int.	88
	3,5
	



260 gr



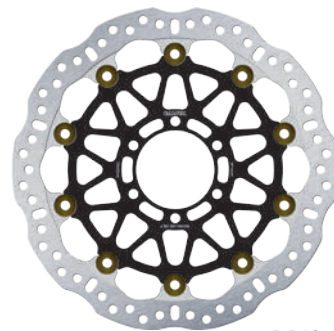

GALFER
DF
112
CW1

 \varnothing ext.	310 mm
 \varnothing int.	69
	5,5
	17,0



1.160 gr



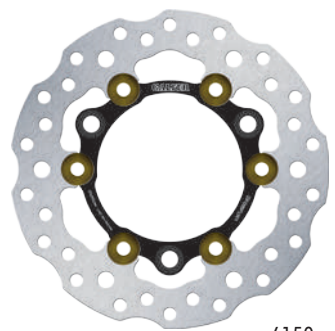

GALFER
DF
096
FLW1

 \varnothing ext.	195 mm
 \varnothing int.	88
	3,5
	0,0



6150 gr



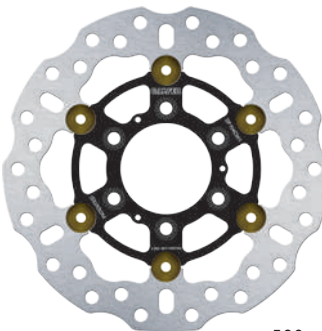

GALFER
DF
104
CW1

 \varnothing ext.	218 mm
 \varnothing int.	60
	4,0
	6,0



580 gr



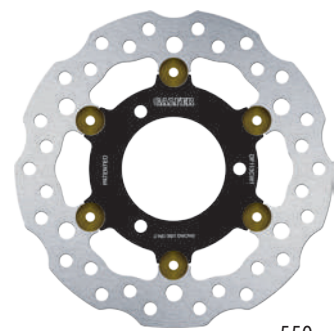

GALFER
DF
113
CW1

 \varnothing ext.	218 mm
 \varnothing int.	70
	4,0
	10,0



550 gr

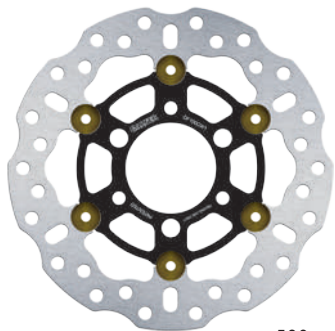

GALFER
DF
100
CW1

 \varnothing ext.	218 mm
 \varnothing int.	60,1
	4,0
	6,0



580 gr



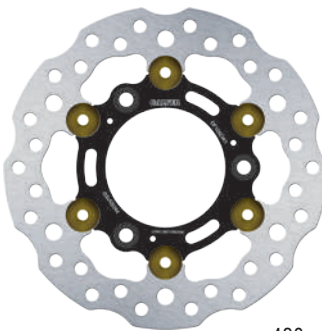

GALFER
DF
105
CW1

 \varnothing ext.	190 mm
 \varnothing int.	70
	4,0
	



420 gr



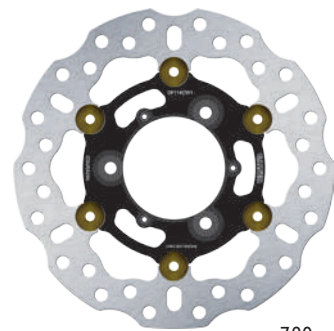

GALFER
DF
114
CW1

 \varnothing ext.	218 mm
 \varnothing int.	69
	4,5
	10,25



780 gr



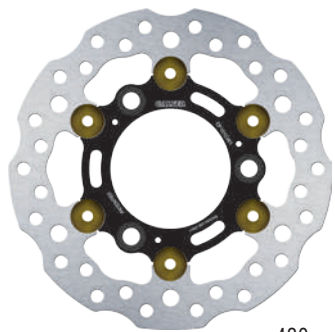

GALFER
DF
101
CW1

 \varnothing ext.	190 mm
 \varnothing int.	70
	4,0
	



420 gr



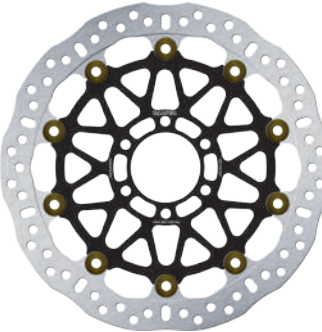

GALFER
DF
110
CW1

 \varnothing ext.	290 mm
 \varnothing int.	60
	5,5
	12,5



1.157 gr



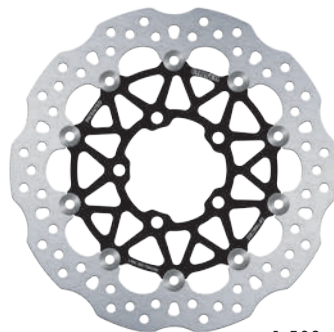

GALFER
DF
184
CW1

 \varnothing ext.	300 mm
 \varnothing int.	80
	5,8
	0,0



1.503 gr



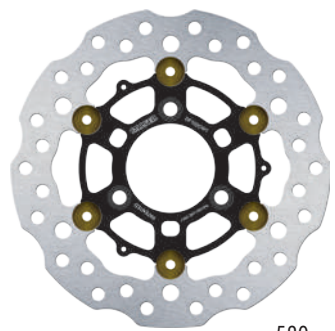

GALFER
DF
102
CW1

 \varnothing ext.	218 mm
 \varnothing int.	60,1
	4,0
	6,0



580 gr



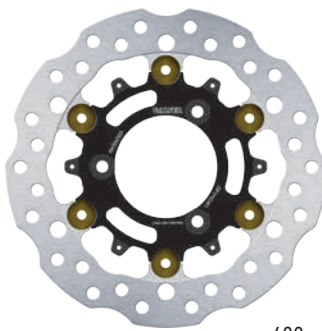

GALFER
DF
111
CW1

 \varnothing ext.	218 mm
 \varnothing int.	69
	4,5
	10,25



680 gr

GALFER
DF
190
CW1

 \varnothing ext.	310 mm
 \varnothing int.	80
	5,5
	0,0

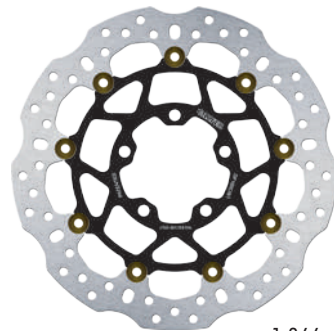

1.366 gr

GALFER
DF
193
W

øext. 220 mm
øint. 100
5,0

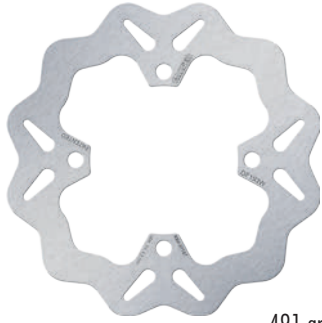

491 gr

GALFER
DF
193
WA

øext. 220 mm
øint. 100
5,0



495 gr

GALFER
DF
194
CW1

øext. 330 mm
øint. 80
5,8
0,0

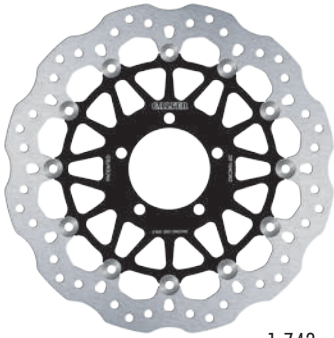

1.743 gr

GALFER
DF
205
CW1

øext. 290 mm
øint. 130
4,5

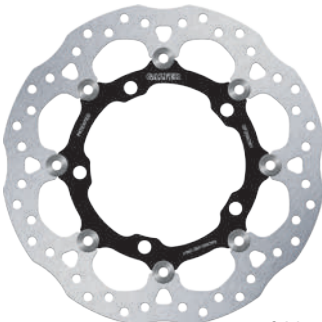

964 gr

GALFER
DF
206
W

øext. 270 mm
øint. 110
5,0

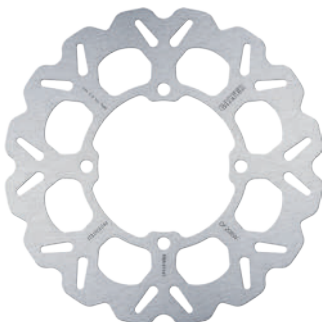

1.150 gr

GALFER
DF
211
CW1

øext. 330 mm
øint. 70
5,8
12,4

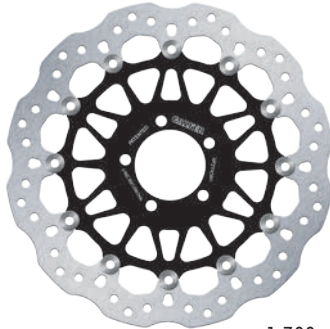

1.700 gr

GALFER
DF
213
WF1

øext. 220 mm
øint. 100
5,0
0,0

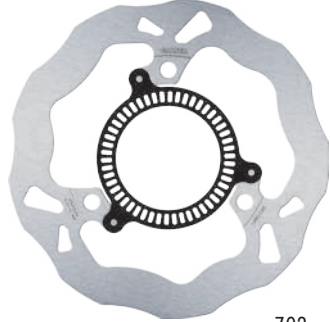

703 gr

GALFER
DF
214
CW1

øext. 310 mm
øint. 142
5,0
0,0

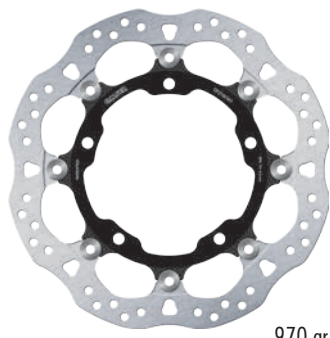

970 gr

GALFER
DF
215
CW1

øext. 300 mm
øint. 142
5,0
0,0

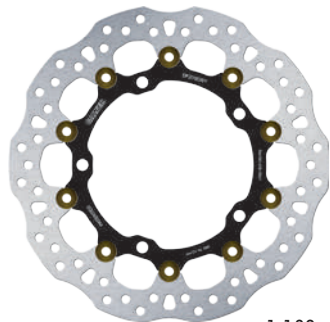

1.189 gr

GALFER
DF
325
CW1

øext. 320 mm
øint. 102
5,0
0,0

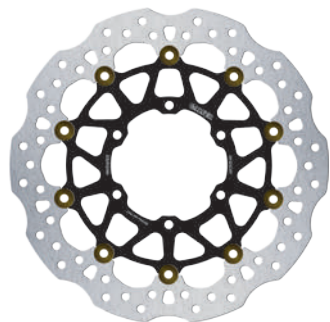

1.358 gr

GALFER
DF
339
W

øext. 220 mm
øint. 89
5,0



729 gr

GALFER
DF
348
CW1

øext. 310 mm
øint. 100
5,0
0,0

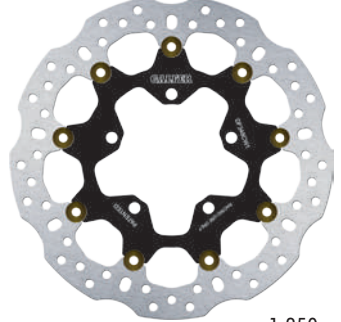

1.250 gr

GALFER
DF
358
CW1

øext. 310 mm
øint. 102
5,0
0,0

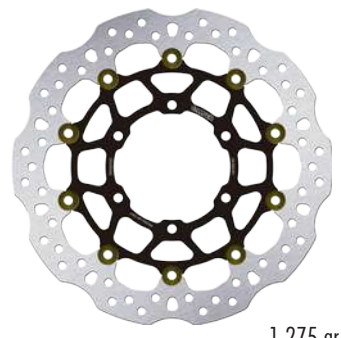

1.275 gr

GALFER
DF
358
CW2

øext. 310 mm
øint. 102
5,0
0,0

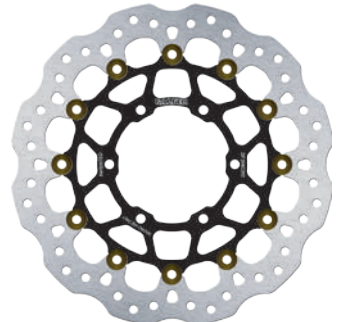

1.425 gr





GALFER
DF
370
W

øext. 220 mm
øint. 110
5,0



662 gr

GALFER
DF
460
CW1

	298 mm
	132
	4,5
	0,0

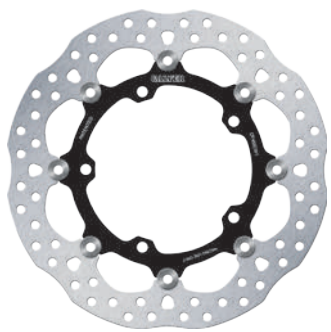

1.030 gr





GALFER
DF
520
CW1-D

	310 mm
	132
	5,0
	0,0



1.290 gr





GALFER
DF
790
W

	230 mm
	104
	4,0
	



567 gr



GALFER
DF
461
W

	220 mm
	105
	4,5
	



600 gr





GALFER
DF
669
WA

	220 mm
	102
	5,0
	



660 gr



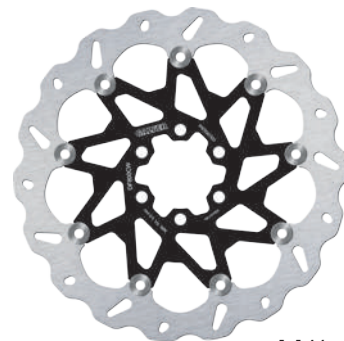

GALFER
DF
800
CW

	300 mm
	60
	5,0
	



1.146 gr



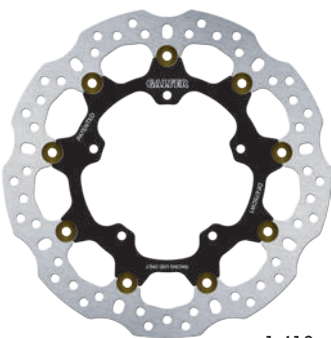

GALFER
DF
475
CW1

	320 mm
	132
	5,5
	0,0



1.419 gr



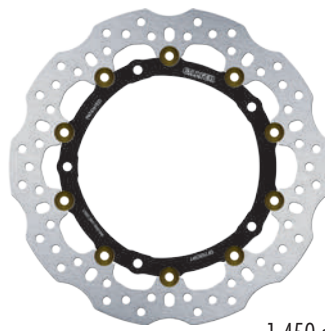

GALFER
DF
755
CW1

	320 mm
	179
	6,0
	



1.450 gr



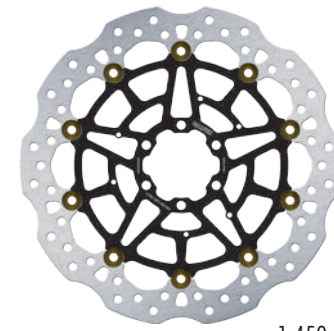

GALFER
DF
817
CW1

	320 mm
	64
	5,5
	



1.450 gr



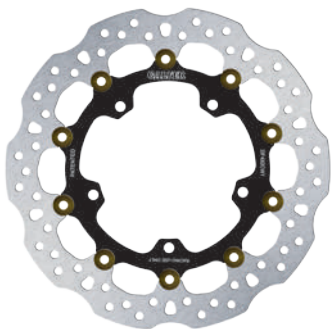

GALFER
DF
482
CW1

	310 mm
	132
	5,0
	0,0



1.200 gr





GALFER
DF
756
W

	220 mm
	120
	5,0
	



615 gr



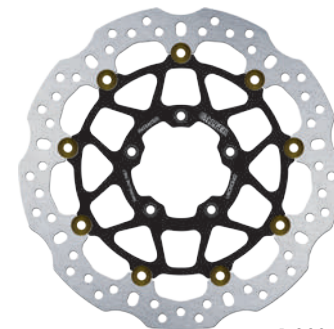

GALFER
DF
830
CW1

	320 mm
	80
	5,0
	



1.380 gr





GALFER
DF
496
W

	220 mm
	105
	4,5
	



640 gr



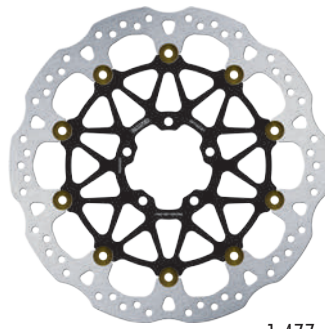

GALFER
DF
774
CW1

	330 mm
	72
	5,5
	15,0



1.477 gr



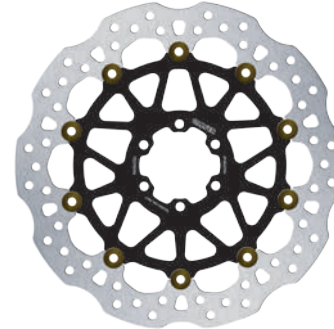

GALFER
DF
883
CW2

	320 mm
	64
	5,5
	10,25



1.579 gr



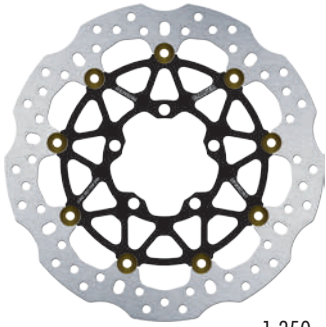

GALFER
DF
906
CW1

 \varnothing ext.	310 mm
 \varnothing int.	83
	5,0
	
	



1.350 gr

GALFER
DF
952
CW1

 \varnothing ext.	330 mm
 \varnothing int.	64
	5,5
	
	

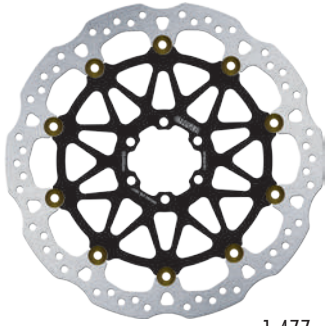

1.477 gr



- The pictures, drawings and all the information contained in this catalog isn't binding in any case, and don't give the right to claim or compensation by the customer.
- Industrias Galfer reserves the right to make changes to their products without prior notice.
- The brake products of this Racing Catalogue are made ONLY FOR COMPETITION USE.
- DO NOT USE DIFFERENT BRAKE PADS AS RECOMMENDED IN THIS CATALOG FOR GALFER BRAKE DISC.

NEW RACING DESIGN

GALFER
Racing

Discwave[®]

Approved by HRC

**Used by Estrella Galicia, Gresini, Leopard & Reale-Avintia
in MOTO GP (Moto3) 2017 + 2018
the new CW1 brake discs**



Ref. DF100CW1
ø 218 x 4,0 mm
HRC Moto3 Front

Ref. DF101CW1
ø 190 x 4,0 mm
HRC Moto3 Rear

GALFER
Racing

NEW RACING DESIGN

Disc Wave[®]

Used in WSBK

By GoEleven (Kawasaki), Evan Bros (Honda)

& Profile Racing (Triumph) in 2016, 2017 + 2018

the new Racing Disc Wave[®]



Ref. DF187CW2
ø 336 x 6,5 mm
Kawasaki ZX-10R Front



Ref. DF475CW1
ø 320 x 5,0 mm
YAMAHA R6 Front



Ref. DF184CW1
ø 300 x 5,8 mm
Kawasaki ZX6R Front



Ref. DF906CW1
ø 310 x 5,0 mm
Triumph Daytona 675R Front

PICTURE	REF.	DESCRIPTION
	1 TUBO	1 TUBE BRAIDED STEEL LINE
	3 VÍAS	3 LINES BRAIDED STEEL LINE ("T" CONNECTOR)
	FK002D2QD	QUICK CONECT LINE (Assembly included)
	FK092D0915	TELEMETRY SENSOR ADAPTER
	LF014R	RACING BRAKE FLUID 500ml
	95998A01	BRAKE DISC CLEANER

Net prices without VAT valid only for competition sold in circuits

CATEGORY	BRAND & MODEL	YEAR MODEL	FRONT	REAR
			FK - BRAKE LINES	FK - BRAKE LINES
SSPP	YAMAHA R-6	05-	FK103C512	FK103C512
	HONDA CBR 600 RR	09-	FK103C588	FK103C588R
	KAWASAKI ZX6R	09-	FK103C584	FK103C719R
	SUZUKI GSXR 600R	11-	FK103C765	FK103C765R
SBK	KAWASAKI ZX10R	13-	FK103CE043	FK103CE043R
	HONDA CBR 1000 RR SP	08-	FK103C641	FK103C641R
	BMW S 1000 RR	09-	FK103CE009	FK103CE009R
	SUZUKI GSX R 1000	12-	FK103C773	FK103C700R
	YAMAHA YZF R-1 / R-1 M	15-	FK103CE056	FK103CE056R



Learn more about motorcycle brake parts we have.