



Harley-Davidson®

photo by Patrick Duval



KOSO 
NORTH AMERICA

Koso's philosophy

Koso, a synonym for quality and performance. With more than 35 years of experience designing and manufacturing high quality products, Koso has become well known across the powersports and OEM industries for its good reputation for reliability, innovation and capability. Whether we are manufacturing a product under private label, OEM or aftermarket products quality always remains our top priority. Innovation and creating new technologies are the keys to Koso's philosophy and drives us to continue pushing the limit further.

For several years now, Koso has had the opportunity to work with and outstanding team of engineers. Along with our state of the art testing equipment and production facilities, Koso has remained a leader in analog and digital technology. Koso produces a wide range of quality gauges/meters, heated equipment, LED indicators taillights and headlights as well as mirrors and engine parts. Koso is proud to offer a complete line of quality products for serious riders.

KOSO 
NORTHAMERICA



HD Oil Dipstick

The Harley Davidson Oil dipstick by Koso is a fast and simple solution to verifying oil level as well as temperature. The push to power technology provides the ability to check your bike's oil vital signs on the go or at a red light with ease.



HD Oil Dipstick

part

BA053101

black casing, fits 2017 + models

BA053111

silver casing, fits 2017 + models

BA053001

black casing, fits 2007 - 2016 Touring models

BA053011

silver fits 2007 - 2016 Touring models

Specifications

- Oil temperature °F or °C
- Oil level
- Low oil level
- 1 step install no wiring needed
- Power: CR2032 battery

new

HD-03L

new

part

BA064910

Blue LED

BA064920

Red LED



Air suspension meter



LED meters for Harley-Davidson® (4 pieces)

For the Harley enthusiasts, we decided to release the updated Baggers meter kit for touring models 2014 and up. This plug & play LED kit from Koso is now available to replace the stock meters without any hassle ! There is no need to drill holes or to rewire the meters, they will fit directly in the OEM dash and connectors. This kit features a dual color changeable LED display (red or blue) for a custom look to fit your motorcycle. The HD-03L kit includes a multifunction speedometer, tachometer, volt meter, a fuel level meter and an air suspension meter. If you're looking to enhance the look of your Harley, Koso has the plug & play solution for you !



PLUG N PLAY

Specifications (R = Range U= Unit)

- **Tachometer**
R: 0 ~ 9,999 RPM | U: 10 RPM
- **RPM Shift-light**
R: 2,000 ~ 8,000 RPM
Warning lights on > value
- **Maximum RPM**
R: 0 ~ 8,000 RPM | U: 100 RPM
- **Speedometer**
R: 0 ~ 199 MPH (0 ~ 299 km/h)
U: 1 MPH or km/h (alternative)
- **Overspeed warning**
R: 19 ~ 199 MPH (30 ~ 299 km/h)
Warning lights on \geq value
- **Maximum speed record**
R: 0 ~ 199 MPH (0 ~ 299 km/h)
- **Odometer**
R: 0 ~ 999,999 miles (km) | U: 1 mile (km)
- **Tripmeter A/B**
R: 0 ~ 9,999.9 miles (km) | U: 0.1 mile (km)
- **Mileage maintenance**
R: Off / 300 ~ 10,000 miles
(500 ~ 16,000 km) ~ -999 miles
U: 100 miles (km)
- **Engine temperature**
R: HD Standard / Customize
- **Fuel meter**
R: 6 levels | U: 1 level = 16.6 %
- **Fuel warning setting**
1-HD Standard
Flashing LCD when > 211 Ω
Off LCD when < 187 Ω
2-HD Customize
Flashing LCD when < 20%
Off LCD when > 30%
- **Fuel tank volume**
OFF / 1 ~ 9.9 US gallons
- **Average fuel consumption**
OFF / MPG (US spec) / MPG (UK spec)
L/100 km / km/L
- **Remaining mileage**
R: 0 ~ 6,249 miles (0 ~ 9,999 km)
LO RNG displayed when < 10 miles
(16 km) | U: 1 mile (km)
- **Oil temperature meter**
R: 32 ~ 248 $^{\circ}$ F (0 ~ 400 $^{\circ}$ C) | U: 1 $^{\circ}$ F or $^{\circ}$ C (alt)
- **Max. oil temperature record**
R: 32 ~ 248 $^{\circ}$ F (0 ~ 400 $^{\circ}$ C)
- **Clock**
R: 12 H or 24 H format
- **Volt meter**
R: DC 8 ~ 18 V
- **Air suspension**
R: 0psi ~ 200psi
- **Digits brightness**
R: 1/5 (darkest) ~ 5/5 (brightest)
- **Indicator lights**
Turn signal / Water temp / Oil level /
Photometric sensing / Warning light/
Check engine / High Beam / Fog light /
Volt / Anti-theft / Cruise / ABS
- **Gear indicator**
OFF, N, P, R, 1, 2, 3, 4, 5, 6
- **Effective temperature range**
14 ~ 140 $^{\circ}$ F (-10 ~ 60 $^{\circ}$ C)
- **Effective voltage** DC 12 V
- **Fits Harley-Davidson® FLHX, FLTC & FLTR from 2014 to 2018**

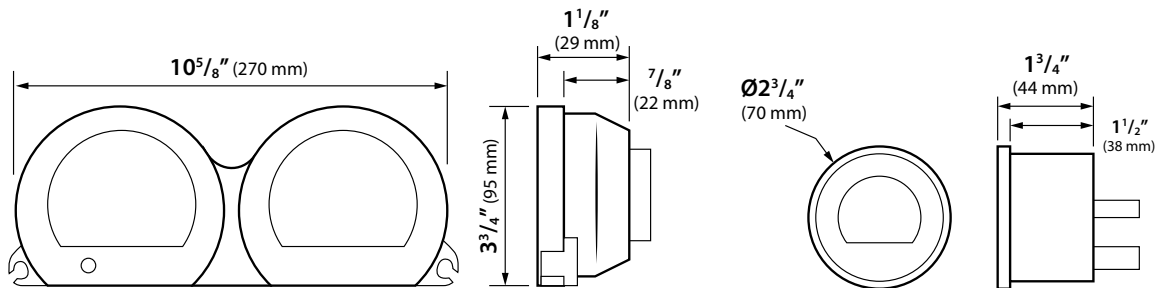

HD-02

part

6 pieces kit, silver bezel, red & blue changeable LCD display

BA050901

with ambient air temp meter

BA050905

with oil temp meter

6 pieces kit, black bezel, red & blue changeable LCD display

BA050903

with ambient air temp meter

BA050907

with oil temp meter



meters for Harley-Davidson® (6 pieces)

Our R&D department worked hard to create something new and modern for Harleys. The engineers responded by coming up with a complete plug & play system to replace the stock meters. No need to drill holes or to rewire the meters, they will all fit directly in the OEM dash and connectors. Both silver and black bezel kits feature a dual color changeable LCD display (red or blue) for a custom look. The 6 piece kit includes a 4" speedometer, 4" tachometer with gear position, 2" oil pressure meter, 2" fuel level meter, a 2" volt meter and the choice of a 2" ambient temperature meter or 2" oil temperature meter. This meter is a great addition to all Harley FLHT, FLHX, and FLTR from 2004 to 2013.

* Fits Harley-Davidson® FLHT, FLHX & FLTR from 2004 to 2013. ** Gauges can be sold separately **



PLUG N PLAY

Specifications for all HD-02 meters

(R = Range U= Unit)

■ Effective temperature range
14 ~ 140 °F (-10 ~ 60 °C)

■ Power DC 12V

HD-02S 4" speedometer

Our plug & play speedometer is equipped with a 2 color changeable LCD display. This meter provides the basic function of speed, odometer and tripmeter. It also includes a clock and all the necessary indicator lights.

BA051000

silver bezel

BA051010

black bezel

Specifications

- **Speedometer**
R: 0 ~ 225 MPH (0 ~ 360 km/h)
U: 1 MPH or km/h (alternative)
- **Speedometer levels**
R: 0 ~ 120 MPH (0 ~ 200 km/h)
U: ± 2.5 MPH (± 4.2 km/h)
- **Odometer**
R: 0 ~ 999,999 miles (km) | U: 1 mile (km)
- **Tripmeter A/B**
R: 0 ~ 9,999.9 miles (km) | U: 0.1 mile (km)
- **Clock** R: 12 H or 24 H format
- **Indicator lights**
Neutral/ Anti-theft / Check engine / Volt / Low fuel



HD-02R 4" tachometer

Our plug & play 0 to 8,000 RPM meter is equipped with a 2 color changeable LCD display. Not only does this meter provide the engine RPM, it displays the gear position, cruise control and ABS indicator light as well. Connecting the instrument to a DC 12 V source of power.

BA051100

silver bezel

BA051110

black bezel

Specifications

- **Digital tachometer**
R: 0 ~ 8,000 RPM
- **Tachometer levels**
R: 0 ~ 8,000 RPM | U: ± 166 RPM
- **Engine temperature**
14 ~ 255 °F (-17 ~ 123 °C)
- **Gear indicator**
N, P, R, 1, 2, 3, 4, 5, 6
- **Indicator lights**
Cruise control / ABS

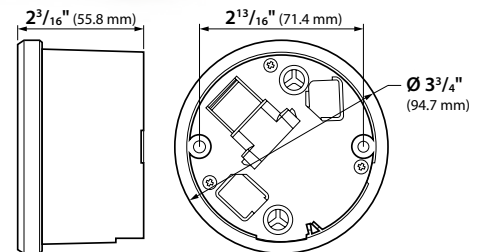

HD-02S 2" oil pressure meter

This plug and play oil pressure meter is equipped with a 2 color changeable LCD display. It provides the engine oil pressure from 0 to 60 PSI.

BA050410

silver bezel

BA050430

black bezel

Specifications

- Oil pressure indicator
R: 0 ~ 60 PSI | U: 1 PSI
- Oil pressure warning
R: 5 ~ 60 PSI | U: 0.1 PSI



HD-02F 2" fuel level meter

This plug & play fuel meter is equipped with a 2 color changeable LCD display. It will precisely display the percentage of fuel left in the tank.

BA050200

silver bezel

BA050210

black bezel

Specifications

- Fuel meter
R: 0 ~ 100% | U: 1%



HD-02V 2" volt meter

This plug & play volt meter is equipped with a 2 color changeable LCD display. It will provide you the battery voltage from DC 8 to 16 volts.

BA050300

silver bezel

BA050310

black bezel

Specifications

- Volt meter
R: DC 8 ~ 16 V | U: DC 1 V



HD-02T 2" ambient air temp. meter

This plug & play ambient air temperature meter is equipped with a 2 color changeable LCD display. It will provide you with the outdoor temperature from 0 to 120 °F and is easy to connect and install.

BA050000

silver bezel

BA050020

black bezel

Specifications

- Ambient air temp. meter
R: 0 ~ 120 °F
U: 1 °F
- Ambient air temp. warning
R: 15 ~ 65 °F
U: 1 °F

* celsius temperature displayed only when used in the 6 pces kit



HD-02F 2" oil temperature meter

This plug & play oil temperature meter is equipped with a 2 color changeable LCD display. It will provide you with the oil temperature from 0 to 400 °F and is easy to connect and install.

BA050500

silver bezel

BA050510

black bezel

Specifications

- Oli temp. meter
R: 0 ~ 400 °F (32 ~ 204 °C)
U: 1 °F (alternative)
- Oil temp. warning
R: 150 ~ 400 °F (66 ~ 204 °C)
U: 1 °F (alternative)

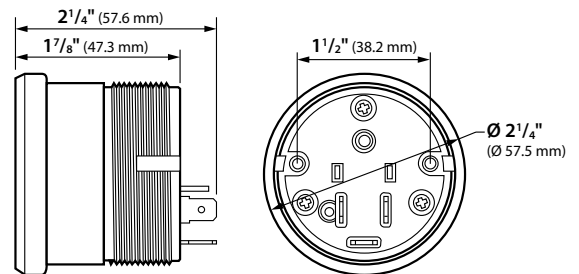

HD-03

part

BA064900

Red & blue changeable LCD display



meters for Harley-Davidson® (4 pieces)

Following the positive reviews we received from Harley enthusiasts, we decided to release the updated Baggers meter kit for touring models 2014 and up. This plug & play kit from Koso is now available to replace the stock meters without any hassle! There is no need to drill holes or to rewire the meters, they will fit directly in the OEM dash and connectors. This kit features a dual color changeable LCD display (red or blue) for a custom look to fit your motorcycle. The HD-03 kit includes a multifunction speedometer, tachometer, volt meter, and a fuel level meter. If you're looking to enhance the look of your Harley, Koso has the plug & play solution for you!



PLUG N PLAY

Specifications (R = Range U= Unit)

- **Tachometer**
R: 0 ~ 9,999 RPM | U: 10 RPM
- **RPM Shift-light**
R: 2,000 ~ 8,000 RPM
Warning lights on > value
- **Maximum RPM**
R: 0 ~ 8,000 RPM | U: 100 RPM
- **Speedometer**
R: 0 ~ 199 MPH (0 ~ 299 km/h)
U: 1 MPH or km/h (alternative)
- **Overspeed warning**
R: 19 ~ 199 MPH (30 ~ 299 km/h)
Warning lights on \geq value
- **Maximum speed record**
R: 0 ~ 199 MPH (0 ~ 299 km/h)
- **Odometer**
R: 0 ~ 999,999 miles (km) | U: 1 mile (km)
- **Tripmeter A/B**
R: 0 ~ 9,999.9 miles (km) | U: 0.1 mile (km)
- **Mileage maintenance**
R: Off / 300 ~ 10,000 miles
(500 ~ 16,000 km) ~ -999 miles
U: 100 miles (km)
- **Engine temperature**
R: HD Standard / Customize
- **Fuel meter**
R: 6 levels | U: 1 level = 16.6 %
- **Fuel warning setting**
1-HD Standard
Flashing LCD when > 211 Ω
Off LCD when < 187 Ω
2-HD Customize
Flashing LCD when < 20%
Off LCD when > 30%
- **Fuel tank volume**
OFF / 1 ~ 9.9 US gallons
- **Average fuel consumption**
OFF / MPG (US spec) / MPG (UK spec)
L/100 km / km/L
- **Remaining mileage**
R: 0 ~ 6,249 miles (0 ~ 9,999 km)
LO RNG displayed when < 10 miles
(16 km) | U: 1 mile (km)
- **Oil temperature meter**
R: 32 ~ 248 $^{\circ}$ F (0 ~ 400 $^{\circ}$ C) | U: 1 $^{\circ}$ F or $^{\circ}$ C (alt)
- **Max. oil temperature record**
R: 32 ~ 248 $^{\circ}$ F (0 ~ 400 $^{\circ}$ C)
- **Clock**
R: 12 H or 24 H format
- **Volt meter**
R: DC 8 ~ 18 V
- **Digits brightness**
R: 1/5 (darkest) ~ 5/5 (brightest)
- **Indicator lights**
Turn signal / Water temp / Oil level /
Photometric sensing / Warning light /
Check engine / High Beam / Fog light /
Volt / Anti-theft / Cruise / ABS
- **Gear indicator**
OFF, N, P, R, 1, 2, 3, 4, 5, 6
- **Effective temperature range**
14 ~ 140 $^{\circ}$ F (-10 ~ 60 $^{\circ}$ C)
- **Effective voltage** DC 12 V
- **Fits Harley-Davidson® FLHX, FLTC & FLTR from 2014 to 2018**

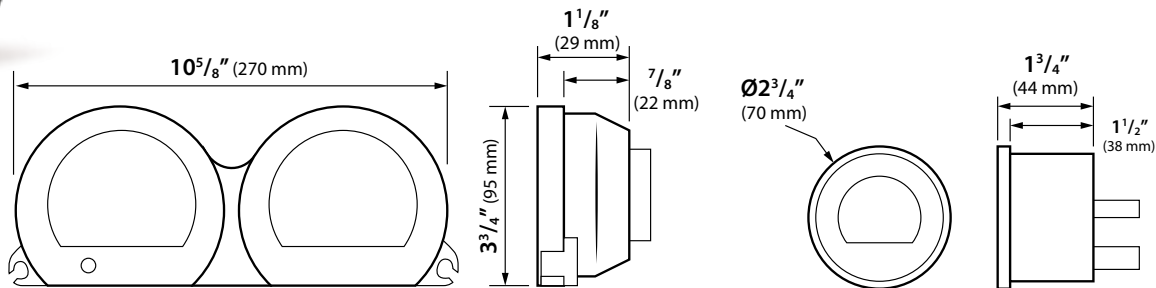

HD-04

part

Fits XL-883 & XL-1200 2004
to 2013 & Dyna 2004-2011

BA051201

silver bezel

BA051211

black bezel

Fits XL-883 & XL-1200 2014+,
Softail 2011+ & Dyna 2012+

BA051221

silver bezel

BA051231

black bezel

meter for Harley-Davidson®

You can now customize your sportster with our high-quality plug & play meter that is equipped with a 8 color changeable LCD display. Its stepper motor provides a precise and fast response so that you can get accurate real time information. Some of the great functions this meter has to offer are : speed, RPM, indicator lights, fuel level, and gear position indicator. Available in silver or black bezel, this is a great modern update for your sportster.



PLUG & PLAY

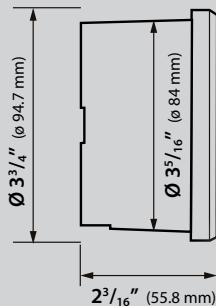

Specifications (R = Range U= Unit)

- **Speedometer**
R: 0 ~ 225 MPH (0 ~ 360 km/h)
U: 1 MPH or km/h
- **Odometer**
R: 0 ~ 999,999 miles (km) U: 1 mile (km)
- **Tripmeter A/B**
R: 0 ~ 9,999.9 miles (km)
U: 0.1 mile (km)
- **Tachometer**
R: 0 ~ 8,000 RPM | U: 100 RPM
- **Shift light warning**
R: 2,000 ~ 8,000 RPM | U: 100 RPM
Warning light on \geq value
- **Maximum RPM warning mode**
R: light on (F-OFF) flash (F-ON)
- **Tire circumference**
R: 50 ~ 210 % | U: 1 %
- **Engine temperature meter**
R: -40 ~ 419 °F (-40 ~ 215 °C)
U: 1 °F or °C (alternative)
- **Fuel level**
R: 6 levels | U: 1 level = 16.67%
- **Clock** R: 12 H or 24 H format
- **Backlight colors**
White / Light Blue / Blue / Purple / Red /
Orange / Yellow / Green
- **Gear indicator**
R: Off, N, 1, 2, 3, 4, 5
- **Indicator lights**
RPM shift light / Check engine /
Oil level / High beam / Turn signals /
ABS / Anti-theft
- **Effective temperature range**
14 ~ 140 °F (-10 ~ 60 °C)
- **Effective voltage** DC 12 V
- **Fits Harley 3 3/8" stock meter mounting cup models**



HD-05

part

BA072100

2004 to 2011 Dyna models
2004 to 2010 Softails models
2004 to 2013 Road King models

BA072000

2012 to newer Dyna models
2011 to newer Softails models
2014 to newer Road King models

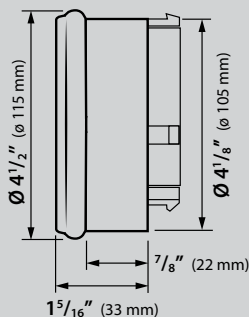

multifunction meter for Harley-Davidson®

The all-new 100% plug and play HD-05 series for 4 ½" gas tank mounted Harley-Davidson® models features a tach and speedo combo with a programmable shift light with gear indicator. This gauge also features vital readings such as engine temperature and battery voltage along with average fuel economy and a complete system of indicators to monitor your bikes vital signs. This plug and play kit fits directly into the stock harness and works directly in relation with your bikes CANBUS system.



Specifications (R = Range U= Unit)

- **Tachometer**
R: 0 ~ 8,000 RPM
- **RPM Shift-light**
R: 2,000 ~ 8,000 RPM | U: 100 RPM
Warning lights on > value
- **Maximum RPM mode**
R: Light on (F-OFF), Flash (F-ON)
- **Speedometer**
R: 0 ~ 225 MPH (0 ~ 360 km/h)
U: 1 MPH or km/h
- **Odometer**
R: 0 ~ 999,999 miles (km) U: 1 mile (km)
- **Tripmeter A/B**
R: 0 ~ 9,999.9 miles (km)
U: 0.1 mile (km)
- **Tire circumference**
R: 50 ~ 210% | U: 1%
- **Engine temperature**
R: -40 ~ 419 °F (-40 ~ 215 °C)
U: 0.1 °F or °C (alternative)
- **Fuel level**
R: 6 levels | U: 1 level = 16.6 %
- **Fuel tank volume**
OFF / 1 ~ 9.9 US gallons
- **Average fuel consumption**
OFF / MPG (US spec) / MPG (UK spec)
L/100 km / km/L
- **Mileage maintenance**
R : Off / 300 ~ 10,000 miles
(500 ~ 16,000 km) | U : 100 miles (km)
- **Remaining mileage**
R : 0 ~ 9,999 miles
LO RNG displayed when < 10 miles
(16 km)
- **Clock**
R: 12 H or 24 H format
- **Volt meter**
R: DC 8 ~ 18 V
- **Backlight brightness**
R: 1/5 (darkest) ~ 5/5 (brightest)
- **Backlight colors**
White / light Blue / Blue / Purple / Red /
Orange / Yellow / Green
- **Indicator lights**
Check engine / RPM shift light /
Low fuel / Volt/ Anti-theft / Cruise / ABS
- **Gear indicator**
OFF, N, 1, 2, 3, 4, 5, 6
- **Effective temperature range**
14 ~ 140 °F (-10 ~ 60 °C)
- **Effective voltage** DC 12 V
- **Fits Harley 5" gauge on gas tank**



Gear indicator

part

KN002010

Specifications

- Gear indicator
R: N, 1, 2, 3, 4, 5, 6
- Effective temperature range
14 ~ 140 °F (-10 ~ 60 °C)
- Effective voltage
DC 12 V

LCD gear display for Harley-Davidson®

Always wondering in which gear you're in? Avoid this question by using our plug & play gear indicator. Lightweight, compact, easy to use and to install, this meter will quickly tell you which gear you've selected. Its big digits and blue backlight make it easy to read during day or night riding. This meter is a great addition for serious riders.

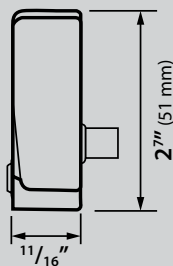
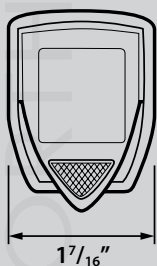

HD-01R

part

BB551B20



tachometer for Harley-Davidson® (with oil pressure)

The HD-01R for Harley-Davidson® features a tachometer and oil pressure meter that serves as a warning function and could prevent damages from occurring to the motor. This meter features with a stepper motor and LCD screen.

* IMPORTANT : Will not work with CANBUS system.



Specifications (R = Range U= Unit)

- **Tachometer**
R: 0 ~ 9,000 RPM | U: ± 100 RPM
- **Stroke / piston setting**
2 stroke: 1, 2, 3, 4 pistons
4 stroke: 1, 2, 3, 4, 5, 6, 8, 10, 12 pistons
- **Oil pressure R:** 0 ~ 75 PSI
- **Effective temperature**
R: 14 ~ 140 °F (-10 ~ 60 °C)
- **Effective voltage** DC 12 V
- **Should be used with**
Harley-Davidson® sensor 74438-99A
(H-D® jumper wire oil pressure sensor 32806-00)
- **Some motorcycles might require**
adjustable RPM signal filter
BO035000 in order to work correctly

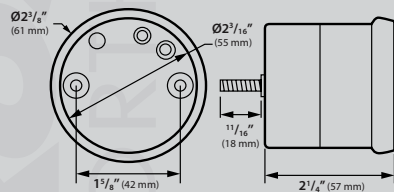

Tachometer

The DL style meter serie is built using a reverse LCD screen that gives it a unique look as they become completely dark when turned off. Another great feature of this meter is its compatibility with the Koso chrome bullet casing.



Specifications

- **Tachometer**
R: 0 ~ 20,000 RPM | U: 100 RPM
- **Tachometer level**
R: 0 ~ 10,000 / 15,000 / 20,000 RPM (alt)
U: 30 levels
- **Stroke / piston setting**
2 stroke: 1, 2, 3, 4 pistons
4 stroke: 1, 2, 3, 4, 5, 6, 8, 10, 12 pistons
- **Temperature level**
R: 68 ~ 248 °F (0 ~ 120°C)
U: 1 level= 50°F (10 °C)
- **Clock 24 H format**
- **Effective temperature**
R: 14 ~ 140 °F (-10 ~ 60 °C)
- **Effective voltage DC 12 V**
- **Sensor type**
Passive speed sensor : BF019005

DL Style

part

BA552B80-HD

tachometer for
Harley-Davidson®

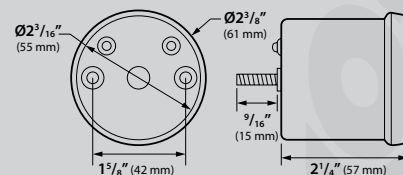
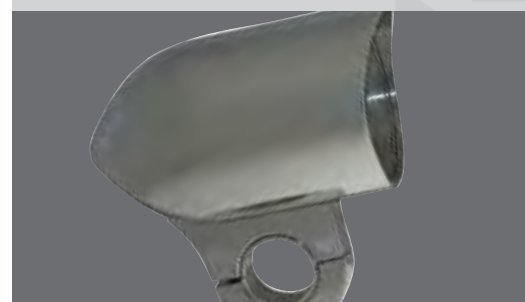

DL-01

part
BA484B20-HD

water temperature for
Harley-Davidson®

BA484B30-HD

volt meter for
Harley-Davidson®

LCD water temperature and volt meters

Koso's DL-01 meters use a reverse LCD display so when the meter is turned off, the screen is deep black. They are available in 3 versions; tachometer that can be programmed for 10K, 15K, 20K with recall function, thermometer with warning and volt meter.

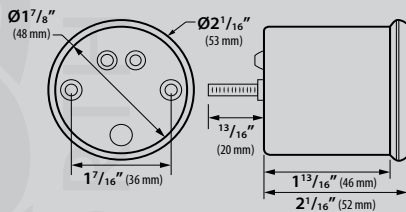

DL-01T Water temperature meter

Specifications

- **Temperature level**
R: 32 ~ 500 °F (0 ~ 250 °C)
U: 1 level = ± 20 °F or ± 10 °C (alt)
- **Digital temperature**
R: 32 ~ 500 °F (0 ~ 250 °C)
U: 1 °F or 10 °C (alt)
- **Temperature warning**
R: 140 ~ 482 °F (60 ~ 250 °C)
HI displayed when over temp
- **Effective temperature range**
14 ~ 140 °F (-10 ~ 60 °C)
- **Power** DC 12 V
- **Sensor included**
Temp. sensor: BF030000 1/8 (BSP) x 28



DL-01V Volt meter

Specifications

- **Volt level**
R: DC 8 ~ 19.9 V
U: 1 level = DC 0.66 V
- **Digital volt meter**
R: DC 8 ~ 19.9 V
U: 1 level = DC 0.1 V
- **Voltage warning**
R: DC 8 ~ 12 V
HI displayed when over voltage
- **Effective temperature range**
14 ~ 140 °F (-10 ~ 60 °C)
- **Power** DC 12 V



DL-02R

part

BA555B19-HD

chrome casing

BA555B16-HD

black casing



GP style tachometer

The DL-02R tachometer has been developed with the latest technology. Its unique casing allows the adjust buttons to be right in the front. This makes the DL-02R a very convenient instrument to adjust. The big digits and blue backlight make the DL-02R a very easy meter to read even at night.



Specifications (R = Range U= Unit)

Tachometer

R: 0 ~ 20,000 RPM | U: 100 RPM

Tachometer level

R: 0 ~ 10,000 / 15,000 / 20,000 RPM

U: 30 levels

■ 10,000 RPM: 1 level = 333 RPM

■ 15,000 RPM: 1 level = 500 RPM

■ 20,000 RPM: 1 level = 666 RPM

Stroke / piston setting

2 stroke: 1, 2, 3, 4 pistons

4 stroke: 1, 2, 3, 4, 5, 6, 8, 10, 12 pistons

Thermometer A/B

R: 32 ~ 482 °F (0 ~ 250 °C)

U: 0.1°F or °C (alt)

Clock R: 24 H format

Effective temperature

R: 14 ~ 140 °F (-10 ~ 60 °C)

Effective voltage DC 12 V

Sensor type

Temp sensor : BF030000 1/8 (BSP) x 28

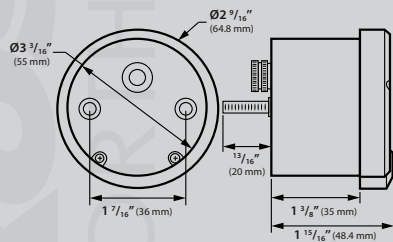

Tachometer

Built with the best components and strongest stepper motor on the market, this TNT-01R tachometer is the perfect addition for all motorcycles. Its large dial face and backlight make it easy to read all day long. Available in black dial face with black casing and white dial face with chrome casing.



Specifications (R = Range U = Unit)

- **Tachometer**
R: 0 ~ 8,000 RPM
Internal display : < 0.5 second
- **RPM input signal number**
R: 0.5, 1 ~ 6
- **RPM input pulse**
R: HI-ACT (positive wave pulse)
LO-ACT (negative wave pulse)
- **Backlight brightness**
R: 1/5 (darkest) ~ 5/5 (brightest)
- **Effective temperature range**
14 ~ 140 °F (-10 ~ 60 °C)
- **Effective voltage**
DC 12 V

TNT-01R

part

BA035112

8, 000 | black / black face
for Harley-Davidson®

BA035102

8, 000 | chrome / white face
for Harley-Davidson®

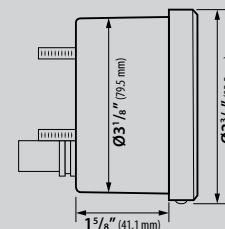

TNT-01S

part

BA035170-HD

black casing / black face
for Harley-Davidson®

BA035160-HD

chrome casing / white face
for Harley-Davidson®

Speedometer

Our TNT-01S multifunction speedometer is the perfect meter for all the Café racers and special projects. The TNT-01S meter uses a stepper motor for a fast and smooth response. The instrument features many functions such as, speed, odometer, tripmeter, fuel meter, clock, voltage, indicator lights and more... This meter is available in black or white face and includes the installation brackets and speed sensor.



Specifications (R = Range U= Unit)

- **Digital speedometer**
R: 0 ~ 225 MPH (0 ~ 360 km/h)
U: MPH or km/h
- **Needle speedometer**
R: 0 ~ 140 MPH (km/h)
- **Odometer**
R: 0 ~ 99,999 miles (km) | U: 1 mile (km)
- **Tripmeter A/B**
R: 0 ~ 999.9 miles (km) | U: 0.1 mile (km)
- **Tire circumference**
R: 300 ~ 2,500 mm | U: 1 mm
Sensitive point: 1 ~ 20
- **Oil maintenance meter**
R: 0 ~ 99,999 miles (km) | U: 1 mile (km)
- **Fuel meter**
R: 6 levels | U: 16.6 %
- **Fuel resistance**
100 Ω / 250 Ω / 510 Ω / 1,200 Ω / SW
- **Volt meter**
R: DC 8 ~ 18 V | Flashing Warning light
(< DC 11.5 V or > DC 15.5 V).
- **Clock** R: 24 H format
- **Backlight brightness**
R: 1/5 (darkest) ~ 5/5 (brightest)
- **Indicator lights**
Neutral / High beam / Turn signals /
Check engine Oil level / Temperature /
Speeding / RPM shift light
- **Effective temperature range**
14 ~ 140 °F (-10 ~ 60 °C)
- **Effective voltage**
DC 12 V
- **Sensor included**
Active speed sensor : BF019005

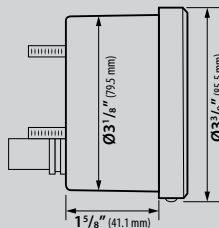

TNT-01

Multifunction Meter

Our TNT-01 multifunction meter is perfect for all the Café racers and special projects. The TNT-01 meter uses a stepper motor for a fast and smooth response. The instrument features many functions such as, speed, odometer, tripmeter, RPM, fuel meter, clock, voltage, shift light, indicator lights and more... This meter is available in black or white face and includes the installation brackets and speed sensor.



Specifications (R = Range U= Unit)

- **Speedometer**
R: 0 ~ 225 MPH (0 ~ 360 km/h)
U: MPH or km/h
- **Odometer**
R: 0 ~ 99,999 miles (km) | U: 1 mile (km)
- **Tripmeter A/B**
R: 0 ~ 999.9 miles (km) | U: 0.1 mile (km)
- **Tire circumference**
R: 300 ~ 2,500 mm | U: 1 mm
Sensitive point: 1 ~ 20
- **Tachometer**
R: 0~10,000 RPM
- **Shift-light**
R: 8,000 ~ 10,000 RPM | U: 100 RPM
- **Warning (shift light)**
R: Light on (F-OFF), Flash (F-ON)
- **RPM input signal number**
R: 0.5, 1 ~ 24
- **RPM input pulse**
R: HI-ACT (positive wave pulse)
LO-ACT (negative wave pulse)
- **Fuel meter**
R: 6 levels | U: 1 level = 16.6 %
- **Effective temperature range**
14 ~ 140 °F (-10 ~ 60 °C)
- **Fuel resistance**
R: 100 Ω / 250 Ω / 510 Ω / 1,200 Ω / SW
- **Clock** R: 24 H format
- **Volt meter**
R: DC 8 ~ 18 V | Flashing Warning light
(< DC 11.5 V or > DC 15.5 V).
- **Backlight brightness**
R: 1/5 (darkest) ~ 5/5 (brightest)
- **Indicator lights**
Neutral / High beam / Turn signals /
Check engine / Oil level / Temperature /
Speeding / RPM shift light
- **Effective voltage**
DC 12 V
- **Sensor included**
Active speed sensor : BF019005

part

BA035K00-HD

black casing / black face
for Harley-Davidson®

BA035W00-HD

chrome casing / white face
for Harley-Davidson®

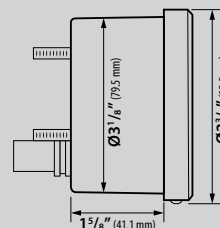

TNT-02

part

BA058100-HD

for Harley-Davidson®

Multifunction meter

With its vintage look, our TNT-02 is the perfect meter for all Café racers and special project bikes that require a small multifunction meter. This 64 mm instrument is a smaller version of our popular TNT-01 and it has the same features such as; speedometer, odometer, tripmeter, tachometer, fuel meter, clock, shift light and indicator lights. Its strong stepper motor allow the reading to be fast and smooth for the best in-time response you can have and its adjustable backlight brightness makes it very easy to read.



Specifications (R = Range U= Unit)

- **Speedometer**
R: 0 ~ 225 MPH (0 ~ 360 km/h)
U: MPH or km/h
- **Odometer**
R: 0 ~ 99,999 miles (km) | U: 1 mile (km)
- **Tripmeter A/B**
R: 0 ~ 999.9 miles (km) | U: 0.1 mile (km)
- **Tire circumference**
R: 300 ~ 2,500 mm | U: 1 mm
Sensitive point: 1 ~ 20
- **Tachometer**
R: 0-10,000 RPM
- **Shift-light**
R: 5,000 ~ 20,000 RPM | U: 100 RPM
- **Warning (shift light)**
R: Light on (F-OFF), Flash (F-ON)
- **RPM input signal number**
R: 0.5, 1 ~ 6
- **RPM input pulse**
R: HI-ACT (positive wave pulse)
LO-ACT (negative wave pulse)
- **Fuel meter**
R: 0 ~ 100% | U: 1 %
- **Clock** R: 24 H format
- **Backlight brightness**
R: 1/5 (darkest) ~ 5/5 (brightest)
- **Indicator lights**
Neutral / High beam / Turn signals /
Warning / RPM shift light
- **Effective temperature range**
14 ~ 140 °F (-10 ~ 60 °C)
- **Effective voltage**
DC 12 V
- **Sensor included**
Active speed sensor : BF019005

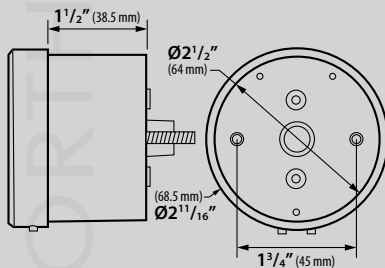

Titan-X

Heated grips for Harley-Davidson®

Finished are the days of searching around for a dial or button to power on heated grips. Our Titan-X heated grips for Harley-Davidson® feature an integrated 5 temperature level thumb switch which allows riders to easily power on/off or adjust the level of temperature without having to remove their hands from the handlebars.* Fits 1" + 1" handlebar



part

AX068K00

Electronic Throttle - Black

AX068M00

Electronic Throttle - Chrome

AX068K10

Cable Throttle - Black

AX068M10

Cable Throttle - Chrome

Specifications

- Integrated temperature level thumb switch
- Universal fitment designed to fit most Harley-Davidson® models
- 5 temperature levels
- 5 color LED indicator to display temperature setting in use
- "Low battery cut off protection"
- Made of aluminium and high quality soft to the touch rubber
- Internal memory that allows the grips to stay at last warmth level
- Anodized black or chrome
- Available for electronic and cable throttle models

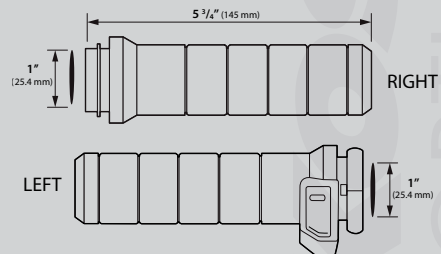

Apollo-X

part

AX118010

Electric throttle

AX118210

Cable throttle

Specifications

- Integrated temperature level thumb switch
- Universal fitment designed to fit most Harley-Davidson® models
- 5 temperature levels to choose from
- 5 color LED indicator to display which temperature setting is currently in use
- “Low battery cut off protection”
Made of soft to the touch rubber composite
- Internal memory that allows the grips to stay at previous warmth level
- Available for electronic and cable throttle models

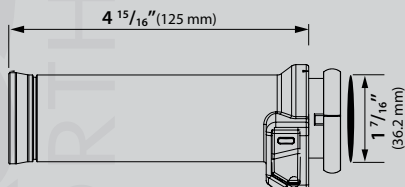

Heated Grips for Harley Davidson®

Stay under the radar with our OE style heated grips. Featuring Koso's innovative thumb switch design which enables riders to easily scroll through temperature levels without taking a hand off the handlebars. Features soft to the touch rubber composite comfortable for short or long rides. Fits HD electronic throttle & fly by wire. Ideal for all season riding. * Fits L: 1" – R: 1" handlebar



Heated grips (for twist throttle)

Also available in an assortment of sizes for motorcycles as well as ATV's and snowmobiles, these 5 level heated grips feature an external controller with 5 levels of heat to choose from. The controller features simply one button to rotate through temperature levels and 5 LED lights to indicate which level of temperature is in use.

The 5 level heated grips also feature a "low voltage cut off protection", this system will automatically detect the voltage of your machine and automatically shut off the heated grips if the voltage happens to fall under 12V.

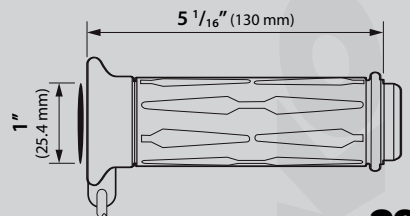

5 Level

part

AM10703G

Fits L: 7/8" – R: 1" handlebar

AM10706G

Fits L: 1" – R: 1 1/8" handlebar

Specifications

- 5 level temperature controller allows you to adjust the temperature to desired comfort level
- "Short circuit protection" and "low battery cut off protection"
- Rubber material that is resistant to outdoor conditions and high temperatures
- Internal memory that allows the grips to stay at last warmth level
- Thin and flexible silicone wires make them easy to install

Multi Adjustment

part

AM10700F

Fits L: 7/8" – R: 1" handlebar

AM10720F

Fits L: 1" – R: 1 1/8" handlebar

Specifications

- Multi adjustment controller allows you to adjust the temperature to desired comfort level
- "Short circuit protection" and "low battery cut off protection"
- Rubber material that is resistant to outdoor conditions and high temperatures
- Internal memory that allows the grips to stay at last warmth level
- Thin and flexible silicone wires make them easy to install

Heated grips (for twist throttle)

Available in an assortment of sizes, twist or thumb throttle. These Multi Adjustment heated grips will keep your hands warm even in the harshest cold weather conditions. The external controller featuring a simple dial and an LED lite background allows you to simply choose your level of temperature even at night time. The Multi Adjustment heated grips also feature a "low voltage cut off protection", this system will automatically detect the voltage of your machine and automatically shut off the heated grips if the voltage happens to fall under 12V.

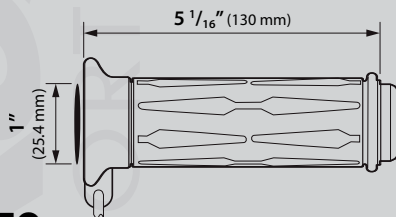

X-Claws

new

Heated Clip-On (for USB power source)

These new heated devices are for the user that does not want to commit to changing their grips but still wants to maintain the comfort of heated grips. The fitment is intended to fit all sorts of handlebar sizes. They can be installed and removed in a matter of seconds and kept in any sports bag when not in use. The power source is a simple connection to your USB port (5V).



part

AX120000

Universal fit

Specifications

- Easy plug and play USB power source (5V)
- Single heating level requires 10W minimum
- Universal fit to be clipped on any handlebar sizes
- Rubber material that is resistant to outdoor conditions and high temperatures
- Thin and flexible silicone wires make them easy to install

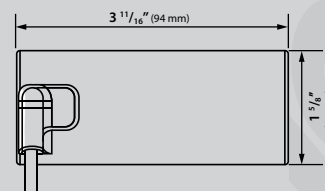
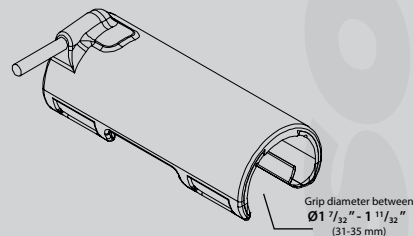

USB-port

part

K0008000



dual USB adaptor for Harley-Davidson®

Our dual USB adaptor exclusively made for Harley-Davidson® models provides you with the possibility of charging your precious devices while riding. Whether it's a GPS, smartphone, tablet or any other small electronic device, our dual USB adaptor provides you with the worry free feeling of knowing your devices will always be charged no matter where the road takes you !



Specifications

- 2 Amps
- Dual port
- Can charge up to 2 iPads simultaneously
- Direct fit
- Short-circuit protection
- Over-heat protection

quick charge dual USB adaptor

Our quick charge dual USB adaptor provides you with the possibility of charging your precious devices quickly. Whether it's a GPS, smartphone, tablet or any other small electrical device, our dual USB adaptor is designed to be installed at any location on you ride since the charging device and the USB output are two separate item.



Specifications

- Output specifications support 3.0 power-charging
DC 5V/ 3A 9V/2A 12V/1.5A
- Dual port
- Can charge up to 2 IPads simultaneously
- Effective temperature range
14 ~ 140 °F (-10 ~ 60 °C)
- Short-circuit protection
- Over-heat protection

USB-port

new

part

K0012000



X1

part

QR000000

regular size smartphone

QR004000

larger size smartphone

new

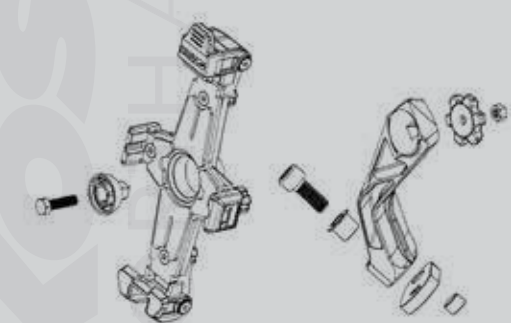

smartphone bracket

Koso X1 smartphone bracket is the most well thought-out and easy to use accessory on the market. It has a mechanical style and is designed to adjust multiple ways, such as; length, height, depth and width, which makes this bracket suitable for any smartphone even those with thick cases. Easy adjustable screws, located on the back, lock the desired positioning securely into place. Most importantly, the top clamp is designed to allow you to insert and remove your smartphone easily by simply pulling it upwards.

* Fits from 7/8" to 1 1/4" Handlebar.



Specifications

- Six-way adjustable
- Quick release & lock function design
- Allowing user to find best position by free adjustable & rotating in 360°
- Thread size : M8 or M10
- **Regular size smartphone bracket:**
 - Min size :** length 4 ¹⁵/₁₆" (126 mm) x 2 ¹/₄" (57 mm) wide x ⁵/₁₆" (7 mm)
 - Max size :** length 6 ¹¹/₁₆" (170 mm) x 3 ¹/₈" (80 mm) wide x ⁹/₁₆" (14 mm)
- **Large size smartphone bracket:**
 - Min size :** length 5 ¹/₂" (140 mm) x 3 ¹³/₁₆" (72 mm) wide x ⁵/₁₆" (7 mm)
 - Max size :** length 7 ⁵/₁₆" (186 mm) x 3 ¹/₂" (91 mm) wide x ⁵/₈" (16 mm)

GPS signal converter kit

Some applications require different alternatives from the conventional speed sensor that is installed on the wheel. Whether it is a question of appearance (for those who do not want wires to be visible), or a question of functionality, this GPS speed signal converter offers more installation options, such as; cars, boats, snowmobiles, and many others ! Its 66 satellite antenna will capture the GPS signal, and the converter will transfer it into a pulse signal that will communicate with the speedometer. A simple, yet versatile accessory that is the future of GPS speed signal converters !



GPS

part

KK000001

complete kit

BF018000

transmitter only

Speed

part

BF620000

Transmission speed sensor for Harley-Davidson®

Built to replace your old OEM transmission sensor, our speed sensor is made from durable material and will function perfectly on your Harley-Davidson®.





Thunderbolt

part

GA002000

Specifications

- Class D brightness level
- Brightness :
 - Low beam : 1058 lumens
 - High beam : 813 lumens
- Built in CNC made housing allowing easy installation
- * E-mark and DOT compliant

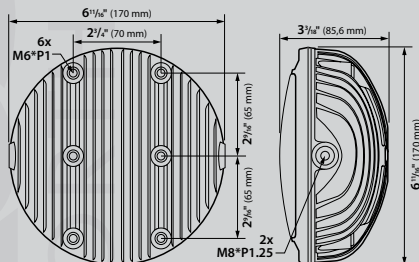

LED headlight

A brighter headlight means more security, this is the reason why Koso decided to release its new Thunderbolt LED headlight. This headlight features a light weight but durable aluminium housing and is one of the only headlights on the market today to be produced using CNC technology. This headlight is universal meaning it can fit virtually any bike and is also DOT certified.



Dual LED headlights

The new Hawkeye dual headlight give an awesome custom look while providing powerful LED brightness. These headlights feature light weight and durable CNC aluminium housing that can be installed on virtually any application. E-Mark and DOT certified.



part

GA004100

dual headlight full kit

Specifications

- Separate low and high beam
- Class D brightness level
- Brightness :
 - Low beam : 1058 lumens
 - High beam : 813 lumens
- Built in CNC made housing allowing easy installation
- * E-mark and DOT compliant

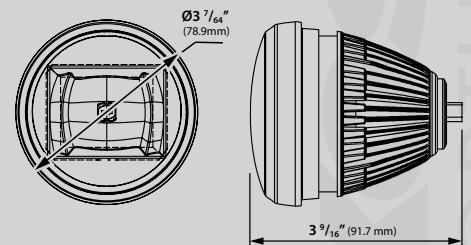

Aurora

part

HG008001

Specifications

LED fog lights

- Brightness: 420 lumens each
- Angle of pitch
+90° / +45° / 0° / -45° / -90°
- Temp range:
14 ~ 140 °F (-10 ~ 60 °C)
- Effective voltage: DC 10 ~ 16 V
- Temp range:
14 ~ 140 °F (-10 ~ 60 °C)

Controller

- Power: DC 12 V / 7 W

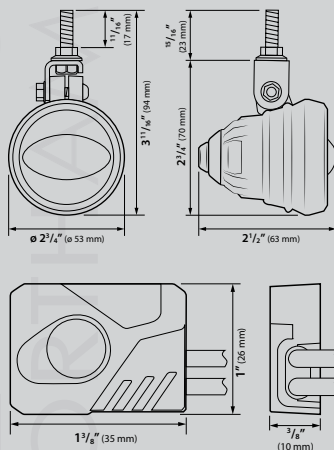

LED fog lights

When it comes to riding motorcycle, security should definitely be a priority. This is why the use of fog lights is a must for seeing and being seen under bad weather conditions. Lightweight, easy to install and adjustable, our Koso quality Aurora fog lights will complement your ride.

* DOT & ECE compliant.



Nano

Nano LED series

Big things come in small packages. The Koso Nano LED series does not disappoint. These pea sized LED indicators are available as turn signals, brake light or a dual function brake light + turn signal combo. Small on size but big on brightness, the Nano(series, collection) features high power LED's that are sure to be seen by all vehicles on the road day or night.



part

HE041001

indicator (pair)

HE041101

dual (pair)

HE041200

brake light (single)

Specifications

- Thread size M6
- Amber turn signal
- Micro size for a clean install
- High power LED

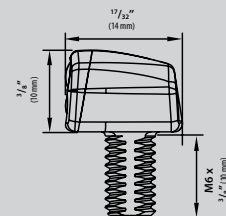

GT-01

new

part

HB031000

red lens

HB031100

smoke lens

Specifications

- Red or smoke lens
- Halo style daytime running light
- 3 ultra-bright LED lights
brake lights

LED taillight

The latest LED technology in the form of a taillight. Whether you are looking to bring your bikes lighting up to date or looking to set your ride apart you can rest assure Koso's Halo taillight will provide. Featuring the latest and greatest Ultra bright LED technology you can rest assure other motorists will spot you on the road all while providing a great modernized look.

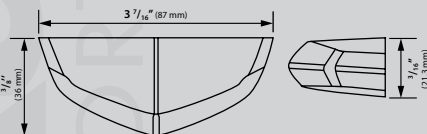

LED taillight

Set your motorcycle apart using the Koso Infinity taillight. Available with red or smoke lens, its 6 ultra-bright LED lights will increase your visibility. This taillight also has a license plate light which makes it better. Affordable and easy to install, this is a must to customize your motorcycle or scooter.



Infinity

part

HB025020

red lens

HB025010

smoke lens

Specifications

- 6 ultra-bright LED lights
- License plate light
- Red or smoke lens

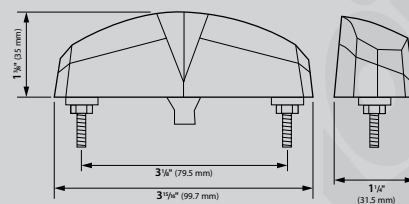

Nano

part

HB026000

red lens

HB026010

smoke lens

Specifications

- 1 ultra-bright LED light
- Red or smoke lens

LED taillight

Our Nano brake light is probably one of the smallest, brightest and lightest taillight on the market. Its ultra-bright LED is made to increase the rear visibility and allow you to ride safely. Its compact shape makes it perfect for all naked bikes and for those who like minimal accessories. Affordable and simple to install, this Nano taillight will certainly enhance the look of your ride !

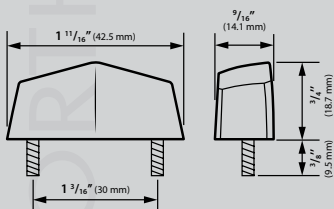

LED taillight

The Koso Solar LED taillight is a great way to modernize the look of your bike. Keeping with the classic circular shell, this taillight is powered by ultra-bright LED's that enable you to be more visible on the road. DOT and SAE approved, this taillight is sure to enhance the look of your bike all while keeping you safer at the same time.



Solar

part

HB035020

red lens

HB035010

smoke lens

Specifications

- Red or smoke lens
- DOT & SAE approved

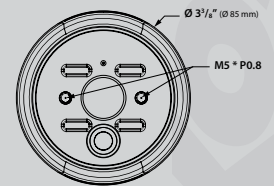
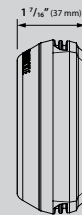

Hawkeye

part

HB034000

red lens

HB034010

smoke lens

Specifications

- Dual function
- 1 ultra-bright LED light
- License plate light
- Red or smoke lens

LED taillight

The Hawkeye taillight is a micro high power LED that also features a license plate light. This taillight may be small however the ultra-bright LED makes it extremely visible during day or night. Universal fitment designed to fit any application.

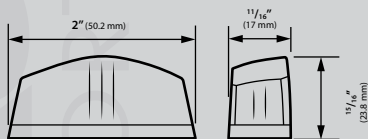

LED license plate light

this new LED license plate light will give you the compact and easy to install license plate light features and bring a stylish twist to your typical license plate light. Its specifications, quality components, and Ultra-bright LED light are the reasons behind its DOT compliance. This item is a must to customize your motorcycle at a low cost.



part

HD009000

Specifications

- Range: DC 10 ~ 18 V
- Max voltage: DC 24 V < 60 sec
- DOT compliant

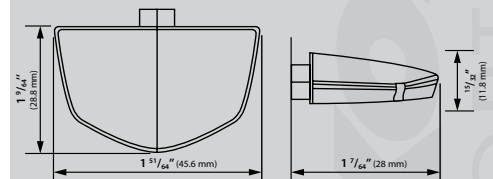

Blade

part

HD008000

Specifications

- Range: DC 10 ~ 18 V
- Max voltage: DC 24 V < 60 sec
- DOT compliant

LED license plate light

Our constant desire to add new products to our accessory line has pushed us to develop a small, compact and easy to install license plate light. Its specifications, quality components and Ultra-bright LED light are the reasons behind its DOT compliance. This item is a must to customize your motorcycle at a low cost.

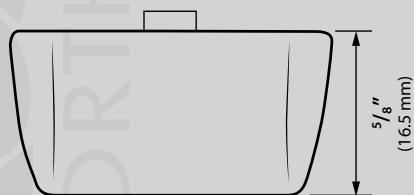
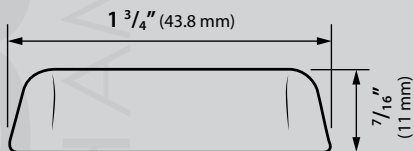

LED indicator lights

The Koso Electro sequential LED indicator is a great addition to any bike regardless of the make or style. The sequential indicator powered by five high powered LED's provides modern style as well as blinding brightness to keep you safe on the road regardless of whether its day or night.



part

HE037021

Amber

HE037011

Smoke

Specifications

- 5 high power ultra-bright LED lights
- Aluminium shell
- Available in clear or amber lens
- Soft stem design
- M8 threading
- Sold as pair

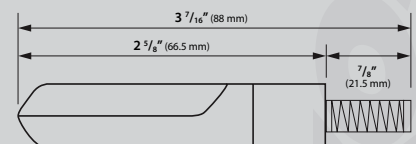

GW-02

new

part

HE044000

Smoke

Specifications

- Dynamic (sequential) indicator
- 5 high power ultra-bright LED lights
- Aluminium shell
- Smoke lens
- Soft stem design
- M8 threading
- Sold as pair

LED indicator lights

The Koso new GW-02 sequential LED indicator gives any bike a style statement. The sequential indicator powered by five high powered LED's provides modern style as well as blinding brightness to keep you safe on the road regardless of whether its day or night.

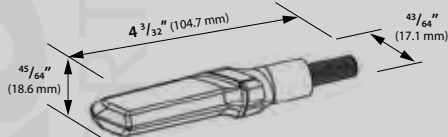

Z3

new

LED indicator lights

The Z3 ultra bright LED indicators by koso are a great set of affordable indicators. Bring your bike to the next level by upgrading your indicators. These Indicators not only happen to look good but they also provide more safety while out on the road with the blinding brightness of high power LED's.



part

HE039200

Amber

Specifications

- 4 high power ultra-bright LED lights
- Plastic shell
- Soft stem design
- M8 threading
- Sold as pair

KOSO
NORTH AMERICA

Nuovo

new

part
HE032010

smoke lens

HE032020

amber lens

Specifications

- 6 ultra-bright LED lights
- Amber LED's
- Amber or smoke Lens
- Soft stem design
- M8 thread
- Sold per set of 2
- DOT, SAE & E-mark approved

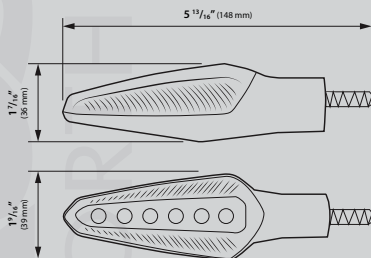

LED indicator lights

The Koso Nuovo LED indicator lights are a great way to modernize the look of your bike without straying away from the OEM appearance. Sold in a pair of two, DOT and SAE certified. These indicators feature 6 ultra-bright LED's per indicator to keep you safer and more visible when changing lanes.



Stinger

LED indicator lights

Looking to customize your motorcycle at a low cost? Our Stinger LED indicators will definitely do the job! They are available in matte black with a choice of smoke or clear lens, and they feature a Hi-power amber LED to increase visibility. Their modern style will be the perfect complementary item to enhance the look of your ride!



part
HE100010
smoke lens

HE100000
clear lens

Specifications

- 1 hi-power ultra-bright LED light
- Amber LED
- Clear or smoke Lens
- Soft stem design
- M8 thread
- Sold per set of 2

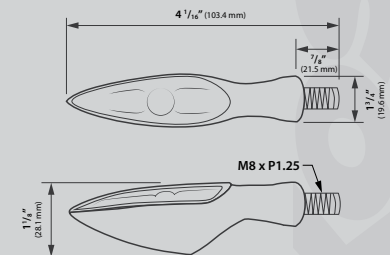

Unlimited

part
HE015K14
matte black

HE015S12
silver

HE015M12
chrome

Specifications

- 5 ultra-bright LED lights
- Amber LED
- Clear lens
- Soft stem design
- M8 thread
- Sold per set of 2

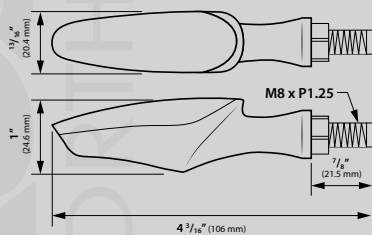

LED indicator lights

Koso Unlimited LED indicator lights use 5 ultra-bright amber LED lights to increase visibility. Sold in pair and available in matte black, silver or chrome, they are perfect to customize your motorcycle at low cost. A simple change, for a better look !



Infinity

Dual LED indicator lights

Koso Infinity LED indicator lights are available in 2 models. The DUAL function is a brake light & indicator light. It is used for the rear end; the other is a SINGLE indicator light function for the front end. They are built with 2 ultra-bright LED, one is RED as the brake light and the other is AMBER as the indicator light. Having a hi-power LED brake light into the indicator light will increase the visibility of the motorcycle and make it easier to see for other drivers. The Infinity dual hi-power LED are not only a matter of look... but also a matter of safety.



part
HE030011

smoke lens / single function

HB030011

smoke lens / dual function

HE030001

clear lens / single function

HB030001

clear lens / dual function

Specifications

- 2 hi-power ultra-bright LED lights
- Amber and redLED
- Clear or smoke Lens
- Dual and single function
- Soft stem design
- M8 thread
- Sold per set of 2

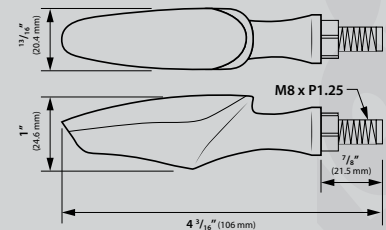

Jet

part

HE101K30

matte black / smoke lens

HE101K20

matte black / clear lens

HE101S10

silver clear lens

Specifications

- 1 hi-power ultra-bright LED light
- Amber LED
- Clear or smoke lens
- Soft stem design
- M8 thread
- Sold per set of 2

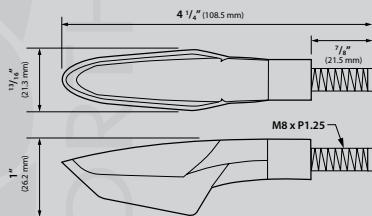

LED indicator lights

Koso Jet LED indicator lights use the new High-power LED technology. In fact, it is so bright that it uses only 1 light for an ultra-bright luminosity. Sold in pair and available in matte black or silver, they are perfect to change the look of motorcycle without any hassle. A simple change for a better look !



LED indicator lights

Koso Mars LED indicator lights use the new High-power LED technology. In fact, it is so bright that it uses only 1 light for an ultra-bright luminosity. Sold in pair and available in matte black or silver, they are perfect to change the look of motorcycle without any hassle. A simple change for a better look !



Mars

part
HE103K11
matte black / smoke lens

HE103K01
matte black / clear lens

HE103S01
silver clear lens

Specifications

- 1 hi-power ultra-bright LED light
- Amber LED
- Clear or smoke lens
- Soft stem design
- M8 thread
- Sold per set of 2

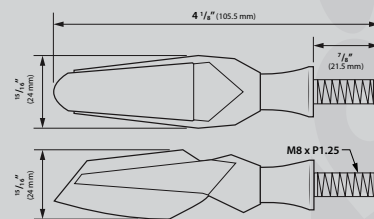

TT-Style

part

A OA016CS0

Carbon look shell / Clear lens

B OA016KS0

Matte black shell / Clear lens

C OA016CK2

Carbon look shell / Clear lens

D OA016CS6

Carbon look shell / Blue lens

E OA016CK6

Carbon look shell / Blue lens

Mirrors

Our TT Style universal mirrors will change the style of your bike for good. Available in M10 size with carbon look or matte black shell.

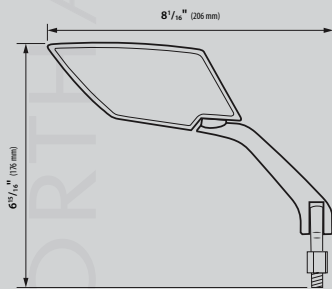

Specifications ———— **A**

- Carbon look shell
- Clear lens
- Silver stem



Specifications ———— **D**

- Carbon look shell
- Blue lens
- Silver stem



Specifications ———— **B**

- Matte black shell
- Clear lens
- Silver stem



Specifications ———— **E**

- Carbon look shell
- Blue lens
- Black stem



Specifications ———— **C**

- Carbon look shell
- Clear lens
- Black stem



Devils Style

part

OA018CK1

Carbon look shell / Clear lens

Mirrors

Get a modern look to your bike with our Devils Style universal mirrors. Available in M10 size with carbon look shell.

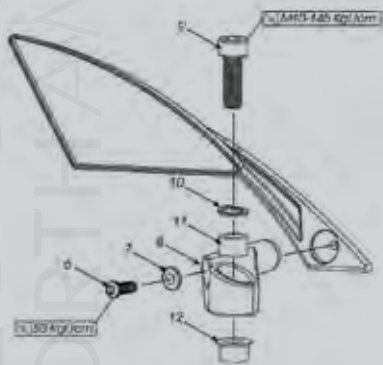

Sprint

new

Mirrors

Large display replacement mirrors that add style to your ride. Our New Sprint Style mirrors will give a unique look to your motorcycle! These mirrors fit M8 and M10 size with black matte stem and shell.



part

SA000003

Black shell / Clear lens

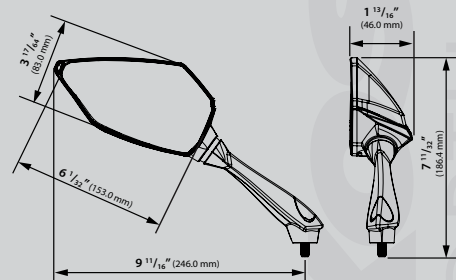

GT Style

part

OA013K10

Black shell / Clear lens

Mirrors

Want something different? Our GT Style mirrors will give a unique look to your motorcycle! Available in M10 size with black matte stem and shell.

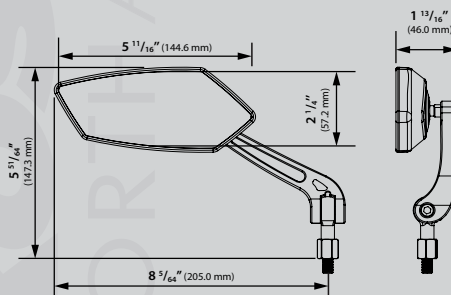

Mirrors

The new Apex mirrors combine look and functionality. You want something different? These mirrors will give a unique look to your motorcycle! Available in M10 size with black matte or carbon look shell.



Apex

new

part

SB000010

Matte black shell / Clear lens

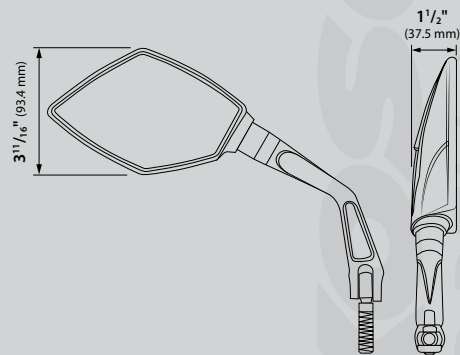



KOSO 
NORTHAMERICA



Learn more about motorcycle gauges and dashboards we have.