

# 2020

MOBILITY  
SOLUTIONS



POWERSPORTS







## HIGHLIGHTS 2020 6

---

### MAGURA HCT 8

HCT Powersports Technology	10
HC1 Radial-Master Cylinder	12
HC3 Radial-Master Cylinder	16
HC3 Colour-Kit	20

---

### HYDRAULIC MASTER CYLINDERS 22

167 Hydraulic brake and clutch master cylinder	22
--	----

---

### MAGURA HYMEC 24

HYMEC Off-Road and HYMEC On-Road	26
HYMEC replacement clutch slave cylinders	29
Build your own HYMEC clutch system	30

---

### MAGURA PERFORMANCE PARTS FOR BMW 32

HYMEC F800, BMW Performance Parts for R-Modelle	34
Repair-Kits for brake master cylinder, replacement levers	35

---

### X-LINE HANDLEBARS 36

---

### CLASSICS 40

73 Sport brake lever	42
73.202 Sport brake dual pull lever	42
74 Sport clutch lever	42
101 Clutch lever	43
108 Brake lever	43
12 Decompression lever	43
225 Hydraulic brake and clutch lever	43
233 Throttle twist grip with mechanical brake	44
273 Throttle twist grip with mechanical brake	44
307 Throttle twist grip	44
309 Throttle twist grip	44
314 Duo throttle twist grip	45
317 Electric throttle twist grip	45
700 Rear brake master cylinder	45

---

### MAGURA SPARE PARTS AND ACCESSORIES 46

HC1 spare parts and accessories	48
HC3 spare parts and accessories	50
167 HYMEC spare parts and accessories	52
Husqvarna spare parts	54
195 Radial master cylinder spare parts	57
167 Hydraulic master cylinder spare parts (brake/clutch)	58
190 Radial master cylinder spare parts	59
163 Hydraulic clutch master cylinder spare parts	60
750/770 Radial supermoto brake system spare parts	61
HYMEC for Harley spare parts	61
Accessoires	62

---

### LIQUI MOLY 66

---

### SERVICE 68

---

Specifications are subject to change with prior notice

Pricing, delivery and other terms and conditions are those in effect at time of delivery.

Any and all riding stunts printed in this catalogue have been completed by professional riders in a controlled environment and are only possible with exceptional skill and experience combined with intensive training. Please do not under any circumstance attempt to replicate these actions!

# HIGH- LIGHTS



HYDRAULIC CLUTCH ACTIVATION THANKS TO MAGURA HYMEC - FOR INCREASED SAFETY AND AN EASIER BIKING LIFE. NOW AVAILABLE FOR POPULAR MODELS SUCH AS THE YAMAHA MT-07 AND MT-09 AS WELL AS THE KTM 790 ADVENTURE.





**BUILT FOR THE ROAD AND AT HOME ON THE RACETRACK** - THE HC3 RADIAL MASTER CYLINDER OFFERS THE OPTION TO COLOUR CODE IT TO MATCH YOUR MOTORCYCLE. THANKS TO THE FULLY RADIAL DESIGN AND THE PATENTED HCT PISTON TECHNOLOGY THIS WORLD CLASS MASTER OFFERS UNIQUE PERFORMANCE AND WE NOW OFFER FIVE COLOUR-KITS TO ALLOW YOU TO PERSONALISE WITH TWO DIFFERENT LEVER AND RESERVOIR OPTIONS - YOU CAN PERSONALISE THE HC3 FOR YOUR MOTORCYCLE.



THE RADIAL FAMILY

# HCT

POWERSPORTS  
TECHNOLOGY





# MADE FOR THE ROAD, AT HOME ON THE TRACK

BRAKE AND CLUTCH ACTIVATION BASED ON HC-TECHNOLOGY IS CURRENTLY AVAILABLE IN TWO DIFFERENT MODEL VARIATIONS. IF YOU CONSIDER YOURSELF TO BE A COMFORT LOVING TOURER, A RACER OR A CUSTOM BIKE FAN EVERY MOTORCYCLE RIDER WILL BENEFIT FROM THE HC-TECHNOLOGY AND MAGURA CAN OFFER THE PERFECT MASTER CYLINDER FOR ALMOST EVERY APPLICATION.

If you have ridden using the brake or clutch activation you will never want anything else thanks to the self designed and patented HC-Technology.

Where a racer requires maximum performance and control, a road rider values the safety and comfort offered by a MAGURA master cylinder.

The patented Hard Core Technology improves the precision of the activation, offers a constant pressure point and is built to last. These qualities are not only required on the racetrack but also play an important role for every road based rider.

The patented HC-Technology is used in the MAGURA radial and slanted radial master cylinder ranges. It improves the response characteri-

stics of your brake and clutch activation while reducing the seal wear inside your master cylinder.

This is made possible through the use of a stationary primary seal and a slotted piston. Besides the performance improvement and increased durability the technology also ensures that seal damage due to ABS kickback is no longer an issue. Every MAGURA HCT radial master cylinder is 100% ABS compatible. (Status Q4.2019)

Both the MAGURA HC1 and HC3 ranges benefit additionally from the „Advanced Seal Technology“. This innovation will reduce or eliminate secondary seal air ingress, as often experienced in race conditions under extreme loads.



POWERED WITH



# HCT

## POWERSPORTS TECHNOLOGY

### REACH ADJUSTER

Set your lever at your preferred reach adjustment.

### 3 WAY LEVER RATIO ADJUSTMENT

Changes the the adjustable point of support to mimic the effect of changing the piston diameter by +/- 1 mm.





### FOLDING LEVER

Avoids damage to the master cylinder in the event of a fall-over.

MACHINED ALUMINIUM BODY

PISTON AND SECONDARY SEAL

### STATIONARY PRIMARY SEAL

Reduces the internal friction, improves the ABS activation. The key to our HC-Technology.



### FEATURES OF OUR HC-TECHNOLOGY:

- Improved feel at the lever due to reduced internal friction
- Increased durability through the reduction of seal wear
- Less pulsation during ABS pressure compensation
- 100 % ABS Compatibility



### TIPP

**MAGURA OFFERS A LOW-COST SERVICE REVISION. THIS IS RECOMMENDED EVERY 10 YEARS OR 100,000 KM.**

STREET KING

**HSC1**

RADIAL MASTER CYLINDER







IF YOUR OWN REQUIREMENTS IN DRIVING DYNAMICS, SAFETY AND COMFORT ARE MORE DEMANDING AND YOU WANT TO MAKE A GOOD BIKE EVEN BETTER, THEN IT'S TIME FOR THE NEW HC<sup>1</sup> FROM MAGURA. THE DECISION TO OPTIMISE YOUR OWN MOTORCYCLE IS MADE EASY BY THIS COMPACTLY-DESIGNED RADIAL FITMENT.

# STREET KING

# HCT

APPROVED BY TWIN CUP GERMANY, EWA STUNTS,  
ROK BAGOROS, HERCZEG BALÁZS MÓKU

## AT A GLANCE:

- 100% ABS-compatible
- Optimal lever kinematics
- Brake lever reach is individually adjustable
- Lever and cylinder parts are forged
- Direct pressure point, sensitive and powerful braking and clutch operation
- ABE included  
(German approval documentation)





The feeling of a direct pressure point offers precision to your brake and clutch activation that benefit every motorcycle fan. If you have experienced the performance of a MAGURA radial master you will not want to use anything else in the future. Thanks to the slanted radial design the HC1 master offers benefits when the available space for the master cylinder is limited due to its compact size and shape.

As with all MAGURA products this ABS compatible radial master stands out by offering perfect ergonomics combined with excellent workmanship down to the last detail. The patented HC-Technology reduces the internal friction adding to the improved feel for your brake.

The HC1 is delivered with a pre-installed brake light switch and a remote fit fluid reservoir. As optional accessories we offer various fluid reservoir types, two different lever lengths as well as an optional mirror mount clamp.

## SERVICE

To retain the full performance of your HC master cylinder we recommend a service revision through our MAGURA Service or from one of our certified service partners. This revision should be done following 100.000 km or 10 years of service.



### HC1 BRAKE MASTER

DESCRIPTION	ORDER CODE
HC1 Brake Master Piston diameter 18 mm, long lever blade	2100453
HC1 Brake Master Piston diameter 15 mm, long lever blade	2100451
HC1 Brake Master Piston diameter 12 mm, short lever blade	2100452

### HC1 CLUTCH MASTER

DESCRIPTION	ORDER CODE
HC1 Clutch Master Piston diameter 16 mm (for DOT), long lever blade	2100457
HC1 Clutch Master Piston diameter 13 mm (for DOT), long lever blade	2100489
HC1 Clutch Master Piston diameter 12 mm (for DOT), long lever blade	2100454
HC1 Clutch Master Piston diameter 13 mm (for mineral oil*), long lever blade	2100456
HC1 Clutch Master Piston diameter 12 mm (for mineral oil**), long lever blade	2100455

\* Suitable for use with BMW and KTM mineral oil clutch activation systems.  
\*\* Suitable for MAGURA HYMEC applications.

### OPTIONAL EXTRAS

(must be ordered separately)

- Short lever
- Mirror mount clamp
- Double banjo connector  
for 2 brake lines
- Radial adapter for HYMEC pressure line
- Various reservoir options

### ITEMS INCLUDED WITH DELIVERY

Every ready-to-mount HC1 is delivered with these package contents:

- Banjo bolt with sealing rings (M10x1)
- Remote reservoir
- Standard clamp (without mirror mount)
- Brake light or start safety switch
- ABE for brake fitments
- Owner's Manual

 **SPARE PARTS AND ACCESSORIES  
ON PAGES 48-49**

IF YOUR MOTORCYCLE IS NOT LISTED IN OUR RECOMMENDED FITMENT LISTING IT IS POSSIBLE TO OBTAIN AN APPROVEMENT BY ARRANGING AN APPOINTMENT WITH YOUR LOCAL TECHNICAL SERVICE (IN GERMANY A PARAGRAPH 19.3 APPROVED BY A STATE APPROVED TECHNICAL INSPECTOR).

TAKE THE LEAD

**HC3**

RADIAL MASTER CYLINDER

BUILT FOR THE ROAD AND AT HOME ON THE RACETRACK. THE HC3 OFFERS THE PERFORMANCE WITHOUT COMPROMISE OF A 90° RADIAL MASTER THANKS TO OUR FULLY PATENTED HC-TECHNOLOGY. THE FEEL IS DIRECT AND EASIER TO CONTROL THAN ANY OTHER MASTER CYLINDER YOU HAVE RIDDEN WITH BEFORE.





# TAKE THE LEAD

# HC3

APPROVED BY YAMAHA KLEIN, SASCHA SCHODER, AARON COLTON, MATTIE GRIFFIN, MEDAZA CYCLES, MARKUS VOLZ, RAPTOR RACING, RACEFOXX, RS RACING KIEFER RACING, DANNY MÄRTZ, LIONCRAFT, DIDIER GRAMS AND HORST SAIGER.

## AT A GLANCE:

- CNC-machined aluminium housing
- 90° radial design
- 3-way adjustable lever bearing point
- 100% ABS-compatible
- Folding lever
- Titanium fixing screws
- ABE included (German approval documentation) and reservoir-kit





**MACHINED ALUMINIUM BODY** – this master cylinder body has been produced from high grade aluminium alloy to ensure a lightweight design combined with maximum rigidity which has been built to last.

**90° FULL RADIAL DESIGN** – Pushrod and cylinder at right angle to handlebar results in decreased friction and more direct brake feeling for improved control.

**FULL ABS COMPATIBILITY** – MAGURA “HCT” is approved for continuous use with all ABS systems without loss of performance due to pressure compensation (ABS-Kickback). (Status 04.2019)

**3 WAY LEVER RATIO** – The hand activated master cylinder lever has a clever 3 way adjustable point of support. This mimics the effect of using a piston size 1 mm below and above the selected hydraulic ratio. Simply remove and reposition the lever support retaining bolt for a softer or harder pressure point. All 3 positions offer 90° full radial activation.

**LIGHTWEIGHT  
CNC LEVER**



**FOLDING LEVER BLADE** – Reduces the force exerted on the master cylinder body in the event of a fall over. This will increase the possibility to continue riding following a fall over incident.

**ADVANCED SECONDARY SEAL TECHNOLOGY** – The rear piston seal has been specially designed to prevent the introduction of air through secondary seal ingress. The advanced X-Ring seal design will reduce or eliminate this problem common on racing motorcycles at higher RPM.

**RESERVOIR MOUNT** – The master cylinder is supplied with an external reservoir and mounting bracket designed to use minimum space and with smoked glass to optically determine the level and condition of the brake fluid at all times.

**TITANIUM RETAINING BOLTS** – Lever and clamp retaining bolts are high grade titanium saving weight while remaining strong and durable.

### HC3 BRAKE MASTER

MODEL	COLOUR	ORDER CODE
HC3 Brake Master Piston diameter 18 mm = 17 to 19 mm (fully ABE approved)	Black Gold	2100691 2100299
HC3 Brake Master Piston diameter 15 mm = 14 to 16 mm (fully ABE approved)	Black Gold	2100689 2100297
HC3 Brake Master Piston diameter 12 mm = 11 to 13 mm, short lever blade, without switch and ABE (race version)	Black Gold	2100690 2100298

### HC3 CLUTCH MASTER

MODEL	COLOUR	ORDER CODE
HC3 Clutch Master Piston diameter 15 mm = 14 to 16 mm (for brake fluid use - DOT)	Black Gold	2100692 2100300
HC3 Clutch Master Piston diameter 12 mm = 11 – 13 mm (for mineral oil use*)	Black Gold	2100693 2100301

\* Suitable for use with BMW and KTM mineral oil clutch activation systems  
Suitable for use with MAGURA HYMEC applications

### OPTIONAL EXTRAS

(must be ordered separately)

- Short fold lever\*
- Mirror mount clamp
- Remote lever adjuster
- Double banjo connector for 2 brake lines
- Radial adapter for HYMEC pressure line

\* Standard equipment on 12 mm HC3 Brake Master for racing

 **SPARE PARTS AND ACCESSORIES  
ON PAGES 50-51**

### DELIVERY INCLUDES

Each HC3 master cylinder comes ready to install and delivery includes:

- 3 Way Lever Ratio (mimics ±1mm hydraulic ratio adjustment)
- Banjo Connector with sealing rings
- Remote Reservoir
- Standard Clamp (without mirror mount)
- Pre-Installed Switch (for brake or clutch activation)
- ABE (German TÜV Approval) for Ø 15 mm and Ø 18 mm brake master
- Owner's Manual

IF YOUR MOTORCYCLE IS NOT LISTED IN OUR RECOMMENDED FITMENT LISTING IT IS POSSIBLE TO OBTAIN AN APPROVEMENT BY ARRANGING AN APPOINTMENT WITH YOUR LOCAL TECHNICAL SERVICE (IN GERMANY A PARAGRAPH 19.3 APPROVED BY A STATE APPROVED TECHNICAL INSPECTOR).

# HC3

## COLOUR-KITS

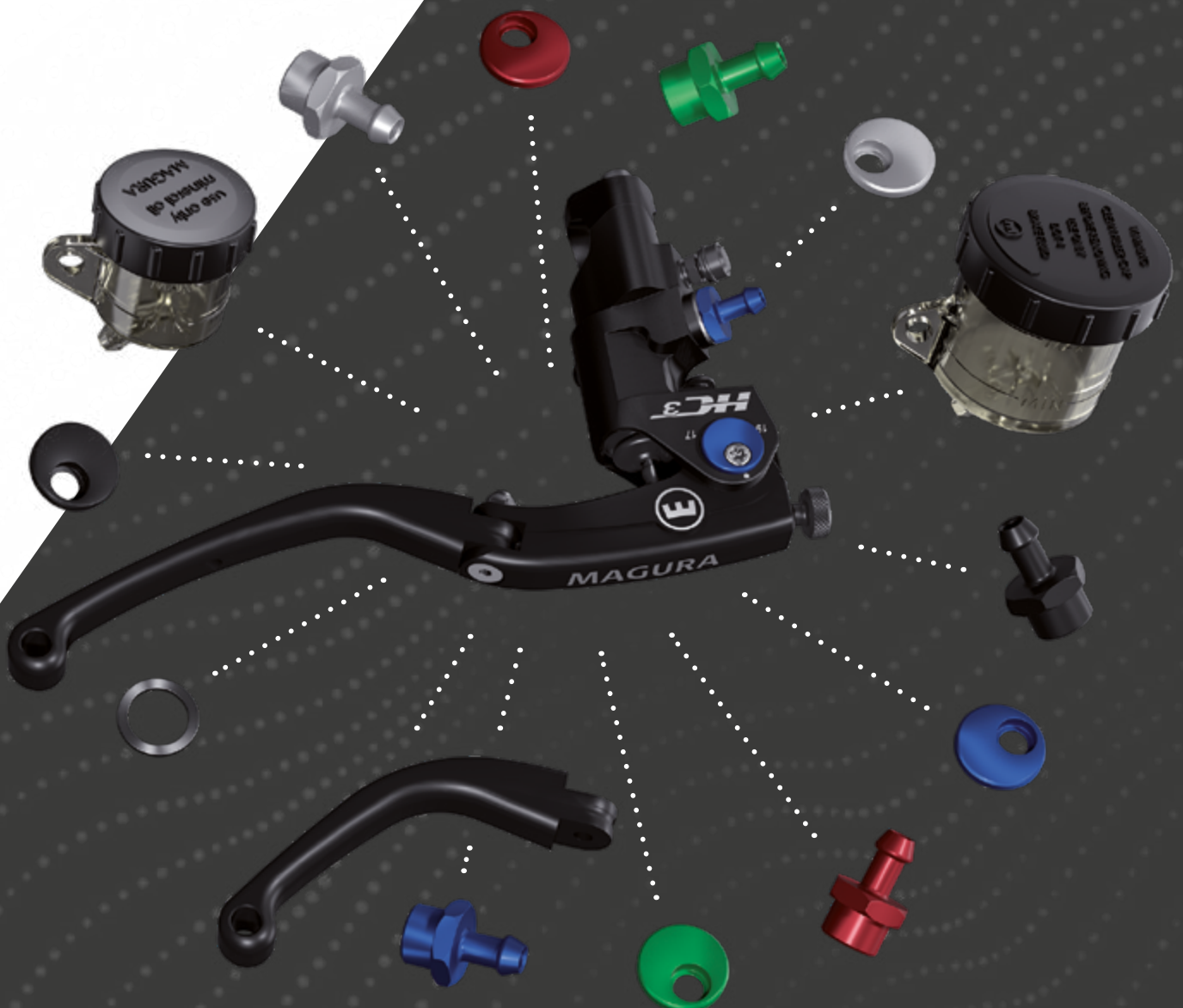

**CUSTOMIZE YOUR HC3.** YOU DECIDE THE DESIGN ON YOUR HC3: WITH THE 5 NEW COLOUR-KITS THE CHOICE IS YOURS. YOU CAN OPTIMISE THE DESIGN ON YOUR HC3 MASTER TO MATCH YOUR MOTORCYCLE. EVERY KIT CONTAINS THE LEVER BOLT COVER AND THE RESERVOIR SOCKET WITH SEALING RING.

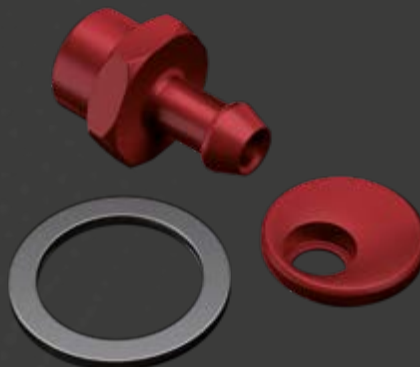

#### HC3 COLOUR-KIT

MODELL	COLOUR	ORDER CODE
Colour-Kit, HC3	black	2701394
Colour-Kit, HC3	red	2701395
Colour-Kit, HC3	green	2701397
Colour-Kit, HC3	blue	2701398
Colour-Kit, HC3	silver	2701399

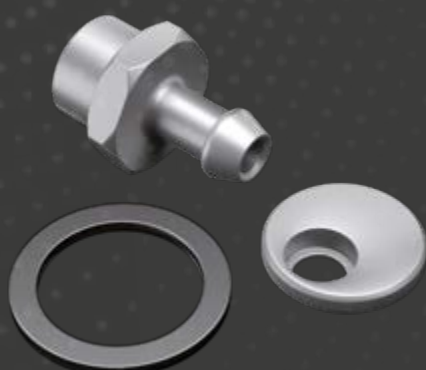
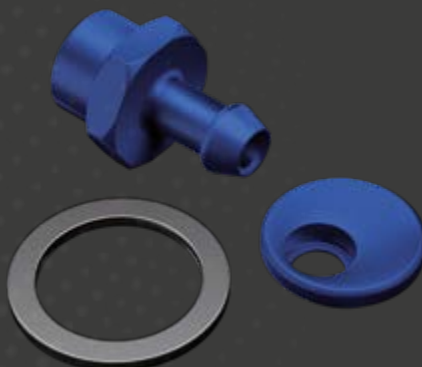



# AXIAL MASTER CYLINDER 167

APPROVED BY  
BOANO RACING  
(ENDURO GP)

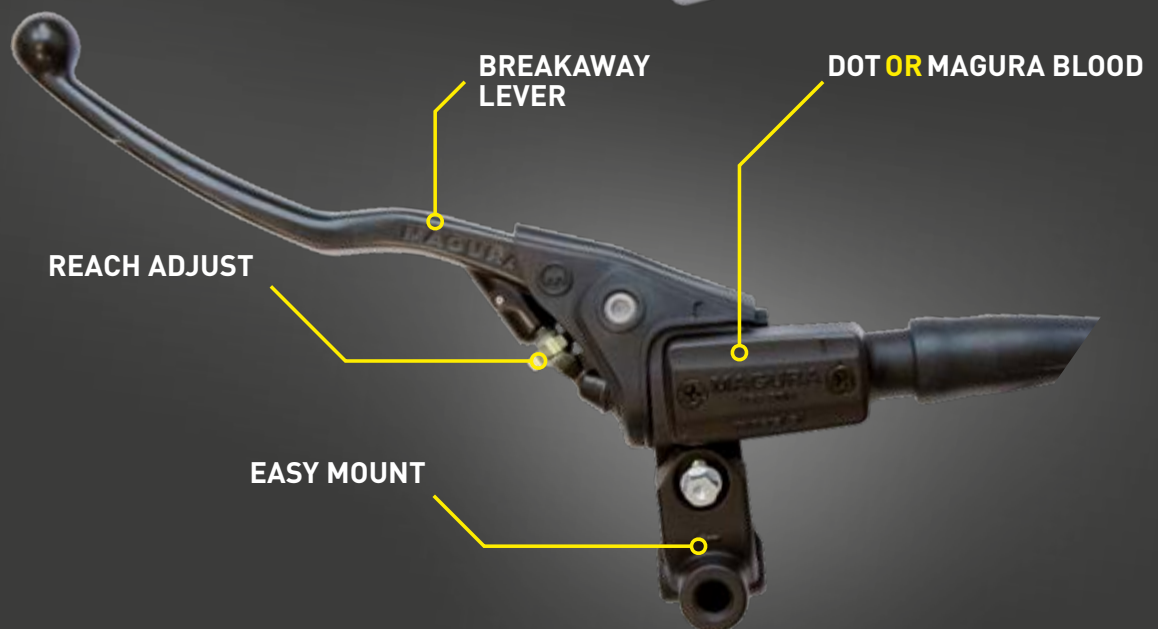

## 167 HYDRAULIC BRAKE AND CLUTCH MASTER CYLINDER

Hydraulic brake and clutch control, one piece aluminium cylinder with reservoir, forged and break-optimised alloy lever blade, improved reach adjust, easy to fit with a folding clamp, the compact construction avoids collisions when riding extreme off road. The cylinder and lever blade pivot are protected against the elements with a rubber cap. Available for use with mineral oil or brake fluid.



MODEL	PISTON-Ø IN MM	MEDIUM	DESCRIPTION/APPLICATION	ORDER CODE
<b>CLUTCH MASTER</b>				
Clutch Master 167.2 ls	9,5	Mineral oil	Black Off-Road Master cylinder, silver lever blade 123 mm without deco lever, clutch switch or mirror-mounting bracket	2701581
Clutch Master 167.1 ls	10,5	Mineral oil	Black Off-Road Master cylinder, silver lever blade 123 mm without deco lever, clutch switch or mirror-mounting bracket	2701582
Clutch Master 167.2 ls	9,5	DOT4/5.1	Black Off-Road Master cylinder, silver lever blade 123 mm without deco lever, clutch switch or mirror-mounting bracket	2701583
Clutch Master 167.1 ls	10,5	DOT4/5.1	Black Off-Road Master cylinder, silver lever blade 123 mm without deco lever, clutch switch or mirror-mounting bracket	2701584
Clutch Master 167.2 ls	9,5	Mineral oil	Black Off-Road Master cylinder, silver lever blade 146 mm, deco lever, clutch switch, mirror-mounting bracket	2700183
Clutch Master 167.1 ls	10,5	Mineral oil	Black Off-Road Master cylinder, silver lever blade 146 mm, deco lever, clutch switch, mirror-mounting bracket	2700186
Clutch Master 167.2 ls	9,5	DOT4/5.1	Black Off-Road Master cylinder, silver lever blade 146 mm, deco lever, clutch switch, mirror-mounting bracket	2700184
Clutch Master 167.1 ls	10,5	DOT4/5.1	Black Off-Road Master cylinder, silver lever blade 146 mm, deco lever, clutch switch, mirror-mounting bracket	2700187
Clutch Master 167.2 ls	9,5	Mineral oil	Black Street Master cylinder, black lever blade 163 mm, deco lever, clutch switch, mirror-mounting bracket	0723295
Clutch Master 167.1 ls	10,5	Mineral oil	Black Street Master cylinder, black lever blade 163 mm, deco lever, clutch switch, mirror-mounting bracket	2700185
Clutch Master 167.6 ls	12	Mineral oil	Black Street Master cylinder, black lever blade 163 mm, clutch switch BMW, mirror-mounting bracket BMW (M10x1.5 mm)	2700482
<b>BRAKE MASTER</b>				
Brake Master 167.60 ef	9,5	DOT4/5.1	Silver Off-Road Master cylinder, silver lever blade 123 mm, with brake light switch and standard mount	2701419



**SPARE PARTS AND ACCESSORIES  
ON PAGE 58**

\* Find clutch switches page 52-53 and 63  
Maximum stroke | 13.8 mm  
Lever ratio | 1:4  
Pressure Line fitting | M10x1

THE RETROFIT HYDRAULIC  
CLUTCH SYSTEM

# HYMEC

SWITCH TO HYMEC AND ACTIVATE YOUR CLUTCH HYDRAULICALLY. OFF OR ON-ROAD, LONG TOURS OR ON YOUR FAVORITE STRETCH - WITH HYMEC EVERY RIDE IS IMPROVED AND UP TO 25% LIGHTER TO ACTIVATE. A CLEARLY DEFINED AND CONSTANT PRESSURE POINT RESULT IN AN EASIER RIDE AND IMPROVED MOTORCYCLE CONTROL:





# HYMEC

APPROVED BY HONDA RED MOTO,  
DIRK MANDERBACH, MOTORRAD KLEIN,  
MOTORRAD MEYER RACING

## AT A GLANCE:

- Reduces the required hand-force during clutch activation
- Improves the feel at the lever
- Easy to mount
- Individually applicable
- Reduced maintenance thanks to lifetime fill

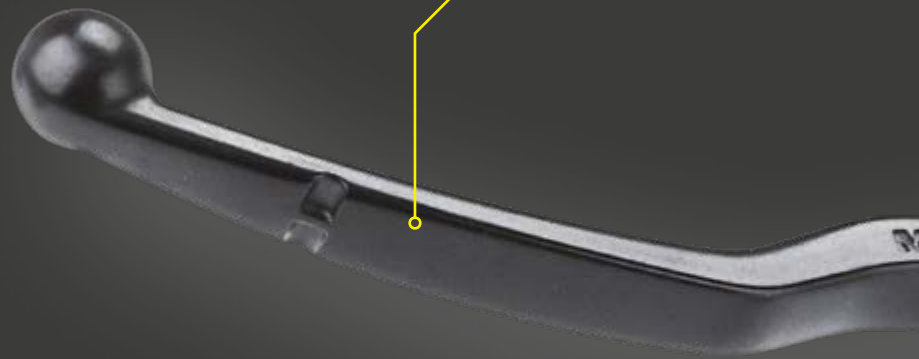

BREAKAWAY LEVER

The hydraulic clutch activation HYMEC is easy to mount and can be used to replace almost all cable clutch activation systems. The HYMEC reduces the activation force and ensures a constant pressure point for Off-Road and Street applications.

The benefits of HYMEC are well known among professional riders and successful teams such as the Honda Redmoto Enduro Team use the system on their Enduro GP motorcycles. This system has helped them to achieve numerous wins and a world title over the years.

Originally designed for use with Enduro and Motocross motorcycles the system has grown in popularity on the street as riders learned the benefits and advantages of the HYMEC. As a result the system has been continuously developed and is already available for a number of current models as a complete plug and play retrofit kit but is also widely used as an individually configurable accessory.

REACH ADJUST

RHR ROTATABLE HOSE ROUTING

EASY FILL



MAGURA HYMEC – AN EASY TO INSTALL ALTERNATIVE TO A MECHANICAL CLUTCH. THIS SYSTEM REPLACES THE CLUTCH LEVER AND CABLE – WITH A SMALL LIGHTWEIGHT HYDRAULIC SYSTEM FOR IMPROVED CLUTCH CONTROL.

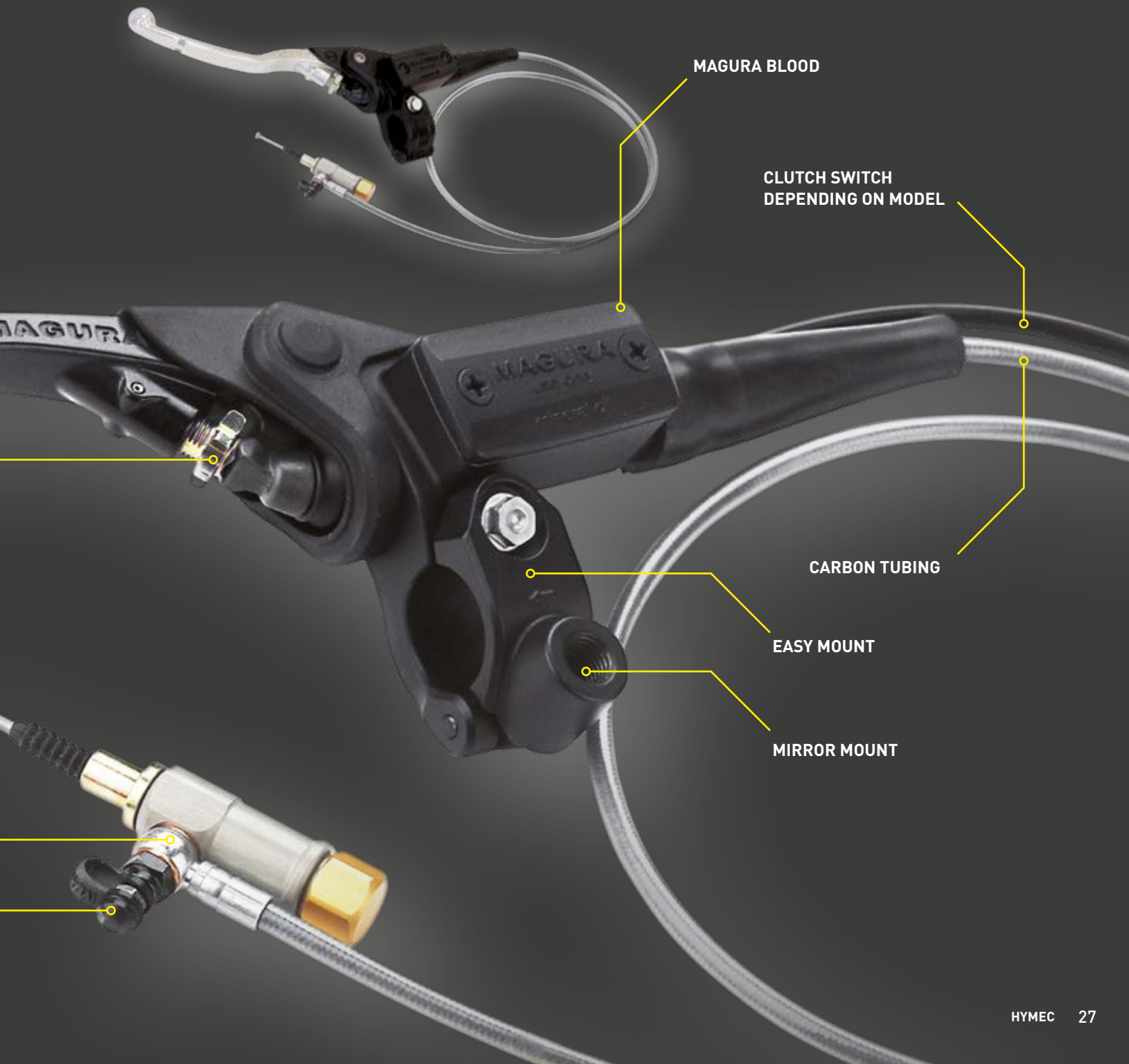

MAGURA BLOOD

CLUTCH SWITCH  
DEPENDING ON MODEL

CARBON TUBING

EASY MOUNT

MIRROR MOUNT



## OPTIONAL EXTRAS FOR YOUR HYMEC SLAVE CYLINDER

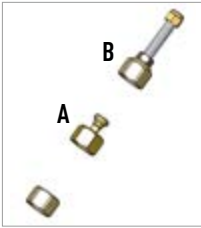

### HYMEC-SLAVE-REAR CAP KIT:

Contains standard, rear mount and rear mount vario cap options.

**ORDER CODE 2100018**



### NIPPLE ADAPTER KIT:

If your clutch cable has a large attachment nipple you will require a nipple for the end of your HYMEC slave cylinder activation rod.

**ORDER CODE 2701674**

Contains both an 11 and 14 mm attachment nipple adapter

### A. REARMOUNT:

If your slave cylinder is attached with a rear mount together with any of the mounting adapters listed on page 52, pos. 28 you may require this REARMOUNT cap.

### B. REARMOUNT VARIO:

This kit enables the fitment of the HYMEC slave cylinder STANDARD as a REARMOUNT VARIO option. The VARIO option allows for adjustment and extends the fitment length by 55 to 77 mm and can be used with all of the slave cylinders listed on page 29.



### 2 STROKE ATTACHMENT KIT:

If the HYMEC slave cylinder is located under the clutch cover it may be necessary to use one of the sleeves in conjunction with an o-ring.

**ORDER CODE 2701697**

## REPLACEMENT HYMEC CLUTCH SLAVE CYLINDERS

If you have an older HYMEC clutch activation system and require a replacement slave cylinder but are not aware of the correct part number we have devised a method to make it easier for you to establish the part number for the replacement. Remove the slave cylinder from the motorcycle and activate the master cylinder until the slave cylinder activation rod is fully retracted and withdrawn. The piston in the slave cylinder is now contacting the bronze cap at the back of the slave cylinder and the rod length should be measured as shown on top of page 29. If the slave cylinder is no longer working it can be removed from the pressure line and forced slowly and carefully into the slave cylinder for the measurement.

Please note – the length you are measuring is not the activation length – the activation length is 16 mm longer than the withdrawn length. Following the measurement please do not disregard your old slave cylinder you may require the cap or the support. All of our replacement HYMEC slave cylinders are delivered with the standard cap and standard support as shown in the pictures. If the slave cylinder you require lies between two different activation lengths – always order the longer version and use spacers between the support and the cable attachment to increase the activation length to suit your motorcycle.

## SPECIAL REPLACEMENT HYMEC SLAVE CYLINDERS

### STANDARD VARIO

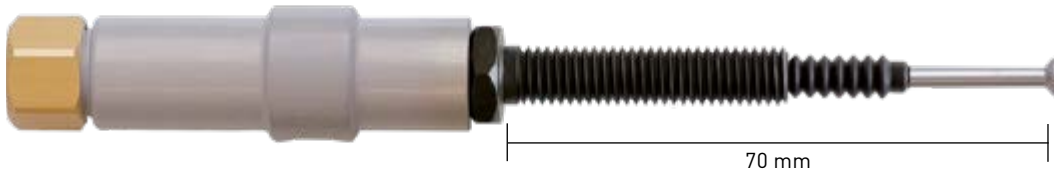

### BMW F 800

- F 700 GS
- F 800 GS
- F 800 R
- F 800 S
- F 800 ST
- F 800 GT
- F 650 GS (2-Cylinder)
- HUSQVARNA NUDA

activation length 57-78 mm

**ORDER CODE 2100022**

### STANDARD BOLT



### HARLEY SPORTSTER AB 1996

Spacer block for assembly should be removed after installation.

**ORDER CODE 0722160**

### STANDARD BOLT



### BUELL XB-MODELLE 2002 – 2010

Spacer block for assembly should be removed after installation.

**ORDER CODE 0120624**

**EXAMPLE**

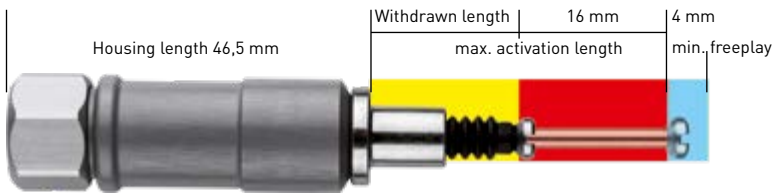

**STANDARD**

Replacement HYMEC Slave Cylinders – to measure your slave cylinder – activate the master cylinder until the pull rod is fully withdrawn.

	WITHDRAWN LENGTH	ACTIVATION LENGTH
A	16 mm	31–33 mm <b>ORDER CODE 2100308</b>
B	24 mm	39–41 mm <b>ORDER CODE 0120649</b>
C	31 mm	46–48 mm <b>ORDER CODE 0120648</b>
D	35 mm	51–53 mm <b>ORDER CODE 0120655</b>
E	41 mm	56–58 mm <b>ORDER CODE 0120652</b>
F	45 mm	60–62 mm <b>ORDER CODE 0120651</b>
G	50 mm	65–67 mm <b>ORDER CODE 2100003</b>
H	55 mm	70–72 mm <b>ORDER CODE 0120653 RRP</b>
J	67 mm	82–84 mm <b>ORDER CODE 0120659 RRP</b>
K	90 mm	105–107 mm <b>ORDER CODE 0120657</b>



# BUILD YOUR OWN HYMEC HYDRAULIC CLUTCH!

HYMEC is the solution for riders with small hands, reduced hand operating force and riders who require a precise clutch activation with a constant pressure point. Due to the number of enquiries we receive for HYMEC systems for motorcycles we have not measured, or have no ready to fit option for, we have completed this double page to assist you in the configuration of a new system. This should enable you to check if the system will fit your motorcycle and which parts list you will require to do so.

The MAGURA HYMEC-System is world renowned as a hydraulic conversion for cable operated mechanical clutch systems. The system is compatible with most clutch activations and offers a direct and constant pressure point. The advantages of this system are well documented in the press and riders forums.

## WHAT DO I NEED TO BUILD A HYMEC FOR MY BIKE?

### 1. MASTER CYLINDER + 2. SLAVE CYLINDER + 3. PRESSURE LINE, FITTINGS AND OIL + 4. SPECIFIC SPARE PARTS

#### 1. MAGURA OFFER 3 MASTER CYLINDER OPTIONS:

Master Cylinder – as the system requires mineral oil and cannot be used with brake fluid the master cylinder should be mineral oil compatible.



**HC1 SLANTED RADIAL MASTER**  
**ORDER CODE 2100455**  
Max. slave stroke: 10 -13 mm\*  
Full details on page 14

HC1 – Reservoir, switch and banjo bolt included

Spare parts and accessoires on page 48/49



**HC3 FULLY RADIAL MASTER**  
**ORDER CODE 2100301 GOLD / 2100693 BLACK**  
Max. slave stroke: 8 -13 mm\*  
Full details on page 18

HC3 - Reservoir, switch and banjo bolt included

Spare parts and accessoires on page 50/51



**167 AXIAL MASTER**  
Ø 9,5 Street (Light operation)  
**ORDER CODE 0723295**  
Max. slave stroke: 8-10 mm\*  
Ø 10,5 Street (Sports clutch)  
**ORDER CODE 2700185**  
Max. slave stroke: 10-12 mm\*  
Full details on page 22  
167 Street Master – switch, mirror clamp and black street lever included

Spare parts and accessoires on page 58

#### 2. PRESSURE LINE, FITTINGS AND SERVICE-KIT

PART DESCRIPTION	ORDER CODE	HC1	HC3	167
<b>A</b> Radial Pressure Line Adapter	<b>2700499</b>	x	x	-
<b>B</b> Pressure Line L=2500 mm cut to size	<b>0722679</b>	x	x	x
<b>B</b> Pressure Line carbon L=1045 mm fixed length	<b>0722138</b>	x	x	x
<b>B</b> Pressure Line carbon L=1120 mm fixed length	<b>0722137</b>	x	x	x
<b>C</b> Banjo Bolt with Bleeder for slave	<b>0722136</b>	x	x	x
<b>D</b> Service-Kit HYMEC (Fill and Bleed Kit)	<b>0722152</b>	x	x	x

Only one pressure line is required for every build. Please measure and define your required length before ordering.



\* Max. Slave stroke refers to possible max. stroke with lever adjusted to largest reach position.

### 3. SLAVE CYLINDER

In order to ascertain the correct slave cylinder for your motorcycle you will need to cut the template slave cylinder from this page, fit to the motorcycle and cut to size. If you do not feel qualified to remove the clutch cable please seek assistance from your local motorcycle technician.

There are 2 basic forms of slave cylinder attachment:

**1. STANDARD cable fitting: Slave template 1**

**2. REARMOUNT VARIO – Slave template 2**

The REARMOUNT VARIO fitting can be adjusted to fit correctly using the rear locknut.



STANDARD template 1



REARMOUNT VARIO template 2

#### STANDARD

Carefully cut the template out and fit to your motorcycle. The clutch activation arm at the engine should be pushed with your finger as far forward towards the slave cylinder as possible and the template should then be cut at the next longest available point.

Then compare the number on the template to the list on pages 28/29 to pick the correct slave cylinder. If the slave is too long it can be shortened by placing spacer washers between the slave and the mounting point – if it is too short it will not work correctly. If in doubt choose the longer version.

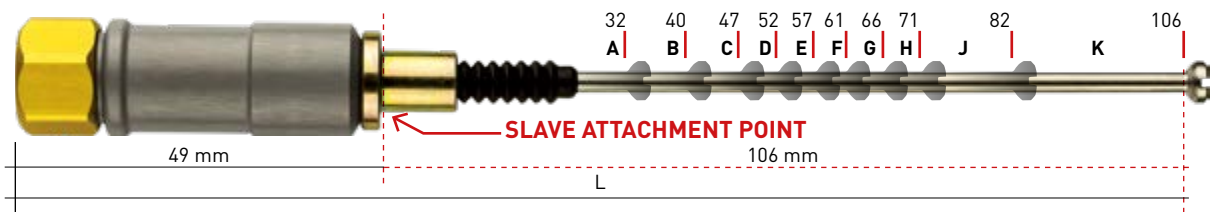

#### REARMOUNT VARIO

Carefully cut the template out and fit to your motorcycle. The clutch activation arm at the engine should be pushed with your finger as far forward towards the slave cylinder as possible and the template should then be cut at the next longest available point.

Then compare the number on the template to the list on pages 28/29 to pick the correct slave cylinder – you will also require **ORDER CODE 2100018 REARMOUNT VARIO Kit** to mount the slave from behind. The threaded attachment kit at the rear should allow for sufficient adjustability when installing the slave cylinder.

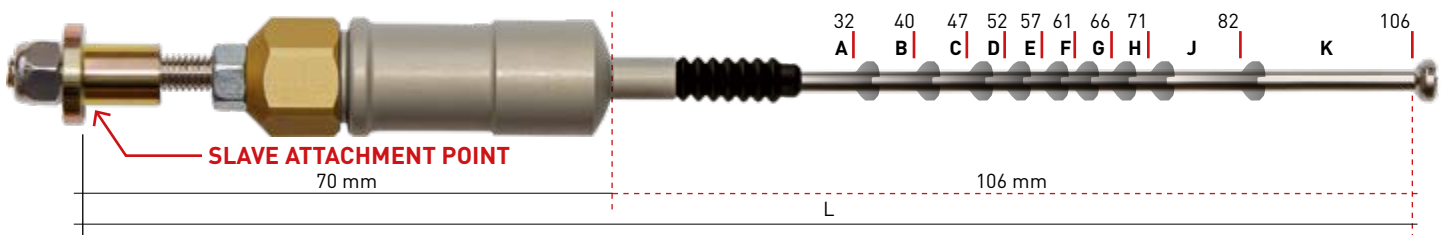

#### POSSIBLE SLAVE CYLINDER DEVIATIONS

Some motorcycle models require a large nipple to attach to the clutch activation arm.

Some 2 stroke models have the cable fitted beneath an engine casing and require a special 2 stroke bracket.



**ORDER CODE 2701674**  
Set with 1x 11 mm and 1x 14 mm



**ORDER CODE 2701697**  
**2 Stroke Attachment Kit HYMEC**  
Includes  
Sleeve 15 mm,  
Sleeve 12 mm, Spacer,  
disc and O-Ring

**BEFORE INSTALLING YOUR NEW HYMEC PLEASE DOWNLOAD THE CURRENT HYMEC-MANUAL FROM OUR WEBSITE! HYMEC DOES NOT AFFECT YOUR VEHICLE REGISTRATION.**

BMW

# PERFOR- MANCE PARTS

AS ONE OF THE OLDEST SUPPLIERS AND PARTNERS TO BMW MOTORRAD OUR EXPERIENCE AND KNOWLEDGE IN THE CHARACTERISTICS AND ADVANTAGES OF THE BMW CONTROLS ARE UTILISED IN THE DEVELOPMENT OF ALL OF OUR ACCESSORY PARTS - IN THE PAST UP TO THE PRESENT DAY.







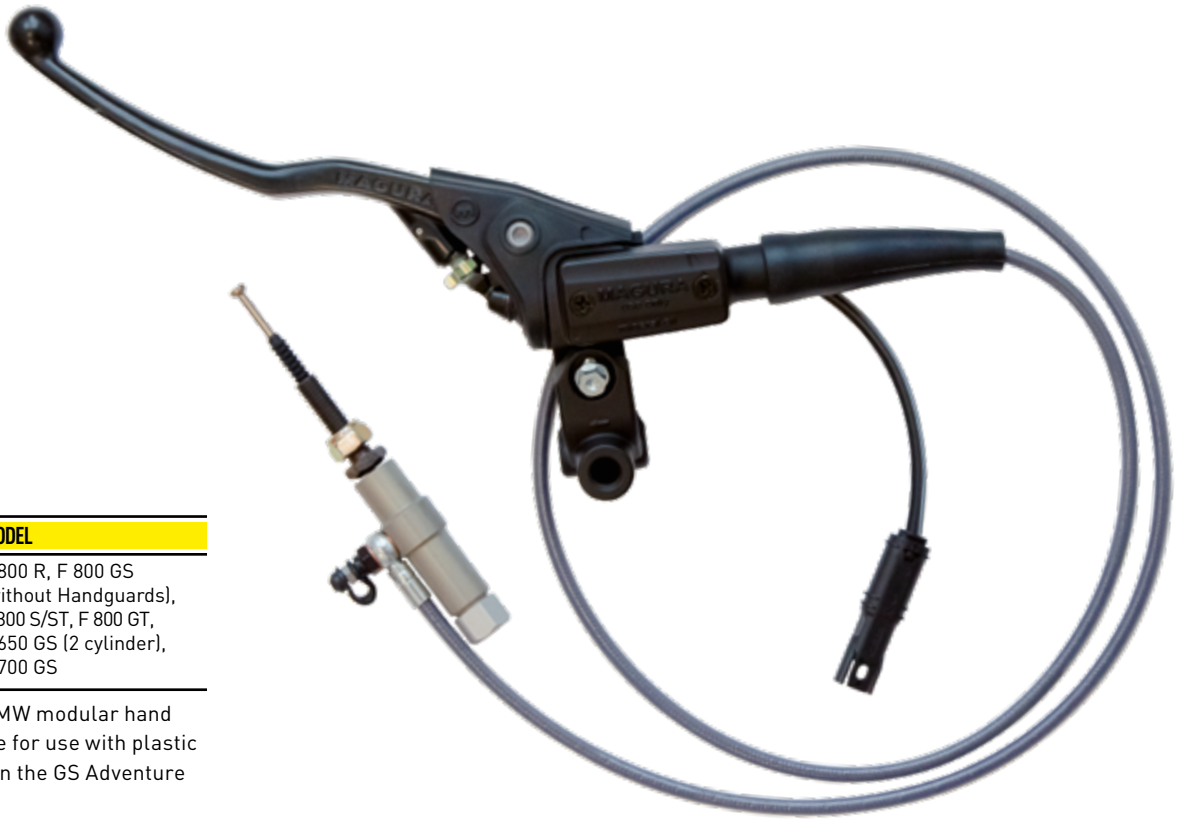

**HYMEC FOR F800**

ORDER CODE	MODEL
2100904	F 800 R, F 800 GS (without Handguards),
<b>SUITABLE FOR ALL MODELS FROM 2006 TO 2018.</b>	F 800 S/ST, F 800 GT, F 650 GS (2 cylinder), F 700 GS

Suitable for use with BMW modular hand protectors. Not suitable for use with plastic hand protectors used on the GS Adventure models.



**WITH ABE**

**BMW PERFORMANCE PARTS**

MAGURA Performance Parts will add value to your motorcycle. They are designed to stand the test of time and can be ordered and fitted separately or together as you wish. The materials used are lightweight, extremely durable and strong. Each product contains over 90 years of motorcycling know-how combined with our passion for perfection.

**Suitable for use on:**

- R 1200 GS LC
- R 1200 GS LC Adventure
- R 1200 R LC
- R 1200 RT LC
- R 1200 RS
- R nineT\*

\* Not suitable for application on models Pure, Racer, Scrambler or Urban G/S



**Order Code 2100546**

**Fold Away Lever Kit** | Fold levers with position detent lock and reach adjust selector are machined from top grade aluminium. Fully ABE tested and approved.

**Order Code 2100547**

**CNC Reservoir Cover Kit** | Honed from top grade aluminium this kit will add optically to your new BMW. Reservoir breather remains fully functional and an optional fluid level sight glass protector is included just in case you intend to use the bike to cross continents.



**APPROVED BY SIMON PAVEY, TOMM WOLF, BMW OFF-ROAD INSTRUCTORS**



Example picture

## MAGURA REPAIR KITS FOR BMW-BRAKE MASTER CYLINDERS

The repair kits for the brake master cylinder models from BMW Motorrad includes: replacement piston with return spring, diaphragm for the fluid reservoir, protective bellows for the piston, as well as an instruction manual and according to the model small additional parts and our MAGURA brake paste.



ORDER CODE 2100017



ORDER CODE 2100016

### REPLACEMENT LEVERS FOR BMW MOTORCYCLE.

MAGURA replacement levers represent an improvement on motorcycles since 1923. The ergonomics, material quality and finish are first class. Tested and approved by the TÜV organisation in Germany these levers meet and surpass the highest standards set for master cylinder operation on a motorcycle. Trust MAGURA to offer the best levers for your bike.

MODEL	YEAR	PISTON-Ø	COMMENT	ORDER CODE
<b>REPAIR-KIT 288</b>				
K1	1988 – 1993	20 mm		2701122
K 1100 RS	1991 – 1996	20 mm		2701122
K 1100 LT	1991 – 1998	20 mm		2701122
R 850 R	1994 – 2001	20 mm		2701122
R 850 GS	1998 – 2000	20 mm		2701122
R 1100 RS	1993 – 2001	20 mm		2701122
R 1100 GS	1994 – 1999	20 mm		2701122
R 1100 R	1994 – 1999	20 mm		2701122
R 1100 RT	1995 – 2001	20 mm		2701122
<b>REPAIR-KIT 286</b>				
R80 G/S	1981 – 1984	12 mm	1 brake disk	2701415
R80	Alle	13 mm	2 brake disks, 2 throttle cables	2701413
R80	ab 1984	14 mm	1 brake disk, 2 throttle cables	2701416
Alle 2-Ventil	1981 – 1984	15 mm	1 brake disk	2701417
Alle 2-Ventil	1980 – 1981	16 mm	2 brake disks	2701414
<b>REPAIR-KIT 285</b>				
R 45/R 65	1981 – 1984	13 mm	1 brake disk	2701413
R 45/R 65	1981 – 1984	16 mm	2 brake disks	2701414

MODEL	YEAR	MODELLCODE	CLUTCH LEVER	ORDER CODE	
650/700	F 650 GS	2007 – 2012	K72	Not available	2100016
	F 700 GS	2013 – 2015	K72	Not available	2100016
800	F 800 GS/Adv	2007 – 2017	K72	Not available	2100016
	F 800 GT	2012 – 2017	K71	Not available	2100016
	F 800 R	2007 – 2016	K73	Not available	2100016
	F 800 S/ST	2007 – 2010	K71	Not available	2100016
	R 1200 GS/Adv	2003 – 2013	K25	2100017	2100016
R 1200 R	2006 – 2014	K27	2100017	2100016	
R 1200 S	2005 – 2009	K29	2100017	2100016	
R 1200 ST	2004 – 2008	K28	2100017	2100016	
HP2 Enduro	2005 – 2007	K25HP	2100017	2100016	
HP2 Megamoto	2007 – 2010	K25/03	2100017	2100016	
HP2 Sport*	2007 – 2010	K29HP	0722112	0722202	
K 1200 S	2005 – 2009	K40	2100017	2100016	
K 1200 R	2005 – 2009	K43	2100017	2100016	
K 1200 R Sport	2005 – 2009	K43	2100017	2100016	
K 1200 GT	2005 – 2009	K44	2100017	2100016	
1300	K 1300 S	2009 – 2015	K40	2100017	2100016
	K 1300 R	2009 – 2013	K43	2100017	2100016
	K 1300 GT	2009 – 2012	K44	2100017	2100016

\*This lever is not pictured on this page – please see 195 Radial Master Cylinder (on page 57)



MAGURA  
HANDLEBARS

# X-LINE

X-LINE HANDLEBARS - THE TAPERED ALUMINIUM HANDLEBAR RANGE FROM MAGURA:  
LIGHT, STRONG, EASY ON THE HAND JOINTS, LONG LASTING WITH A BALL BURNISHED FINISH.  
ALL MAGURA BARS ARE TESTED TO THE HIGHEST STANDARDS AND ARE DELIVERED WITH  
CERTIFICATION FROM THE GERMAN TÜV PRODUCT TESTING ORGANISATION.





# X-LINE

## HANDLEBARS

APPROVED BY MATTIE GRIFFIN, ROK BAGOROS,  
CHRIS PFEIFFER, DIRK MANDERBACH,  
CHRIS RID, EWA STUNTS,  
MOTORRAD MEYER RACING, BVZ RACING.

### AT A GLANCE:

- Light
- Ergonomically designed
- Robust
- Reduced rider fatigue

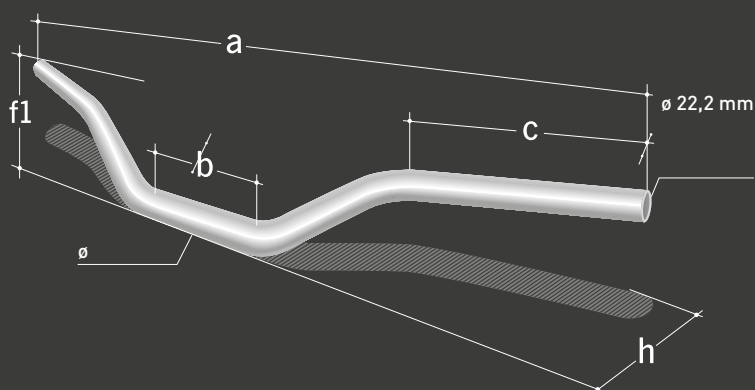

MODEL	COLOUR	DIMENSIONS IN MM						ORDER CODE
		a	b	c	f1	h	Ø	
AX2 Big-Enduro Handlebar	Silver	827	134	230	206	100	28,6	0723198
MX2 Motocross, Supermoto	Silver	808	135	189	119	77	28,6	0721245
CX »Street«	Silver	805	135	200	117	76	28,6	0723050
EX Enduro	Silver	795	135	186	120	87	28,6	0721053
SX Supercross, Supermoto, Motocross	Silver	808	135	189	120	63	28,6	0721055
TX Touring	Black	797	139	217	138	97	28,6	0723248
FX Streetfighter	Black	750	137	210	98	107	28,6	0723247
SX »Street«	Black	808	135	189	120	63	28,6	0723221
CPX – Chris Pfeiffer Edition	Black	797	131	231	113	76	28,6	0723283
RBX – Rok Bagoros Edition*	Black	797	131	231	113	76	28,6	2701965
RBX – Rok Bagoros Edition*	Black	792	116	231	112	74	26	2701776

\* Clamp Diameter 26 mm. Only suitable for KTM Duke models with 26 mm handlebar clamp dimension.



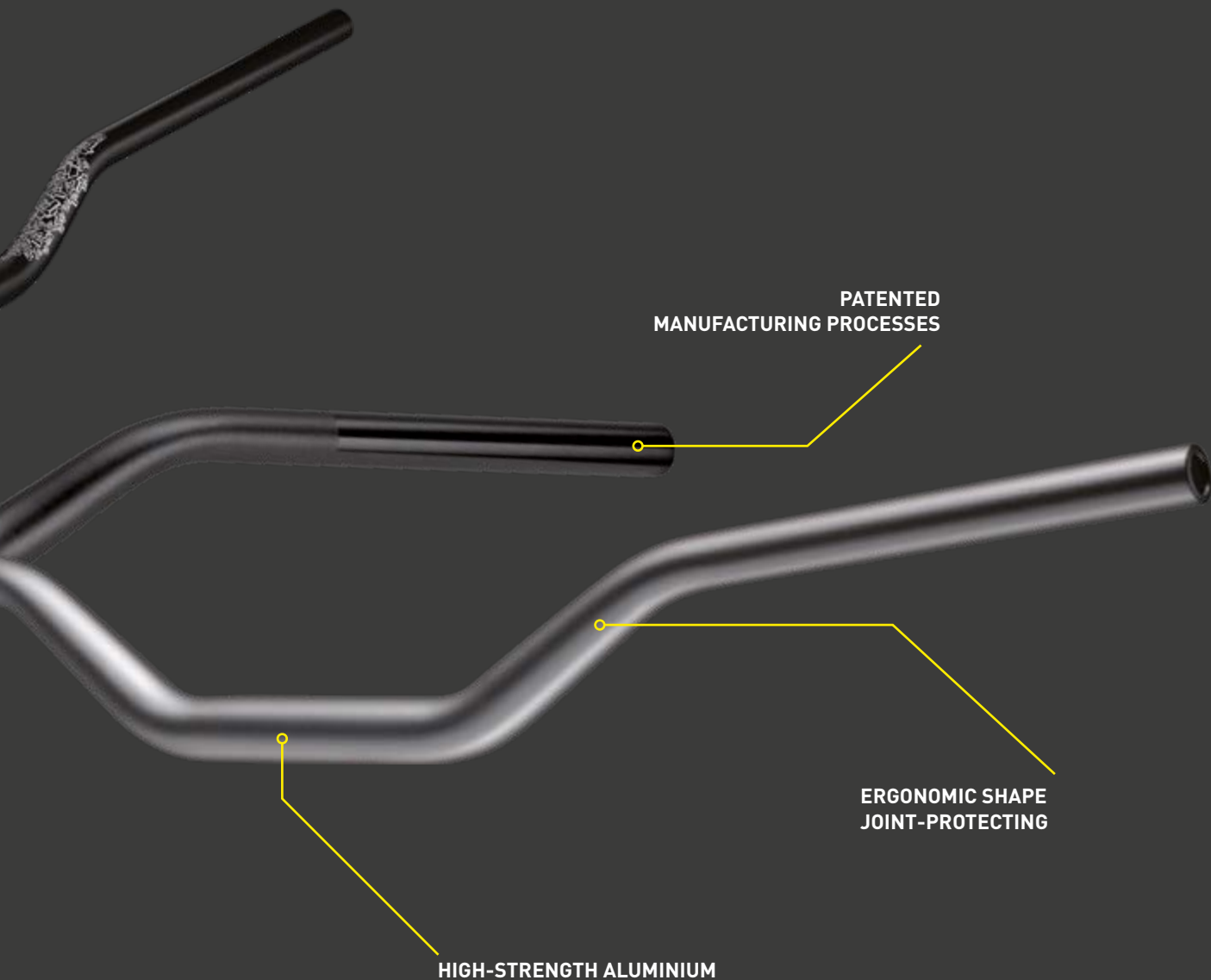

PATENTED  
MANUFACTURING PROCESSES

ERGONOMIC SHAPE  
JOINT-PROTECTING

HIGH-STRENGTH ALUMINIUM

## ACCESSORIES

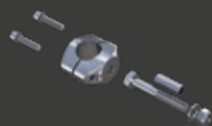

X-line fork clamp kit for bikes with split clamp. Screw M 10 x 70, with bushings.

ORDER CODE  
0720474



X-line clamp kit for one piece clamp/fork bridges. Fits HONDA, YAMAHA, SUZUKI etc., hole distance 32-36 mm. Allows fitment of 28,6 mm tapered handlebar into a standard 22 mm clamp.

ORDER CODE  
0720488



MAGURA-Barpad, black

ORDER CODE  
0723058

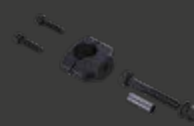

Black X-line "Street" clamp kit for bikes with split clamp (complete). Screw M 10 x 70, with bushings.

ORDER CODE  
0723270



Black X-line "Street" clamp kit for 22 mm clamp conversion, clamping range 32-36 mm. Allows fitment of 28,6 mm tapered handlebar into a standard 22 mm clamp.

ORDER CODE  
0723271

SPARE PARTS  
FOR OLDTIMER  
AND CLASSIC  
BIKES

# CLASSICS







MAGURA CLASSIC PARTS ARE MORE THAN JUST GOOD LOOKING CONTROLS. MANUFACTURED WITH THE SAME QUALITY STANDARDS AS OUR MODERN COMPONENTS THEY OFFER EVERY RESTORER, ENTHUSIAST OR COLLECTOR THE PERFECT FUNCTIONALITY, DURABILITY AND QUALITY.





### SPORT BRAKE LEVER 73

Sport brake lever for mechanical brakes (drum brakes). Light weight forged alloy black split perch clamp and polished Eurostyle ball-end blade, 160 mm long, Ø 8.2 mm hole for rearview mirror.

MODEL	DESCRIPTION/APPLICATION	ACCESSORIES	ORDER CODE
B-lever 73.2	Thread 1/4" for brake light switch (0128496)	Nipple barrel, solder nipple, adjusting screw and protective cap	0116933

Technical data: Cable pull 20 mm | thread M7 for adjusting screw



### SPORT BRAKE LEVER DUAL PULL 73.202

Sport brake lever for mechanical brakes (twin drum brakes). Light weight forged black split perch clamp and polished ball-end lever, 160 mm long, Ø 8.2 mm hole for rearview mirror.

MODEL	DESCRIPTION/APPLICATION	ACCESSORIES	ORDER CODE
B-lever 73.202	Dual-cable pull, with equalizer, to operate two drum brakes	Soldernippel	0116934

Technical data: Cable pull 20 mm | thread M7 for adjusting screw



### SPORT CLUTCH LEVER 74

Sport clutch lever, light weight forged alloy black split perch clamp and polished, Eurostyle ball-end blade, 160 mm long, Ø 8.2 mm hole for rearview mirror

MODEL	DESCRIPTION/APPLICATION	ACCESSORIES	ORDER CODE
C-lever4.1	Cable pull 20 mm at 3.9 ratio, HUSQVARNA, KTM, MAICO etc.	Nipple barrel, solder nipple, adjusting screw and protective cap	0116940

Technical data: Cable pull 20 mm | lefthand thread M7 for cable adjusting screw



### PROTECTION CAP SET

Protection cap set for 73 Sport brake lever and 74 Sport clutch lever

MODEL	DESCRIPTION/APPLICATION	ORDER CODE
Protection cap set 73/516 ksz	Protection cap set for 73 Sport brake lever and 74 Sport clutch lever	0735083



### CLUTCH LEVER 101

Clutch lever with clamp for tube-Ø 22 mm, with thread M6 for adjusting screw or supporting hole Ø 6.5 mm for cable.

MODEL	DESCRIPTION/APPLICATION	ACCESSORIES	ORDER CODE
C-lever 101.2.9	Black shank with thread for adjusting screw, black fibre reinforced lever blade, SPARTA	Adjusting screw, barrel, nipple	0117380 <b>B</b>
C-lever 101.4.8	Black shank with thread for adjusting screw, polished aluminium lever blade with stop notch	Barrel, nipple, s-nipple	0117421
C-lever 101.7.9	Black shank with supporting hole and thread for switch, black fibre reinforced lever blade with pull back spring, PUCH, TOMOS	Barrel, nipple	0117496 <b>B</b>
C-lever 101.8.9	Black shank with thread M6 and thread for switch, black fibre reinforced lever blade with pull back spring	Adjusting screw, barrel, nipple	0117514 <b>B</b>

Technical data: Cable pull | 18 mm, length of lever blade 125 mm, blade with ball end Ø 18 mm



### BRAKE LEVER 108

Brake lever righthand for tube-Ø 22 mm, cable supporting hole, alloy lever blade or reinforced fibre lever blade.

MODEL	DESCRIPTION/APPLICATION	ORDER CODE
B-lever 108.4.9	Righthand, black fibre reinforced lever blade, thread for brake light switch, pull back spring, supporting hole	0119570

Technical data: Cable pull | 18 mm



### DECOMPRESSION LEVER 12

Decompression lever, shank Ø 22 mm with supporting hole Ø 6.7 mm, cable fixing with clamp screw, cable pull 16 mm.

MODEL	DESCRIPTION/APPLICATION	ORDER CODE
Lever 12	Decompression lever, shank Ø 22 mm with supporting hole Ø 6.7 mm, cable fixing with clamp screw	0111370

Technical data: Cable pull | 16 mm



### HYDRAULIC BRAKE AND CLUTCH LEVER 225

Hydraulic brake and clutch lever, black painted housing with a (22 mm) clamp, polished alloy lever, thread for brake light switch and hole Ø 8.1 mm or thread M8 for rear-view mirror, thread M10 x1, plastic brake fluid reservoir. Obtainable as righthand and lefthand model. Fitting brake and clutch switch see page 63

MODEL	PISTON Ø IN MM	DESCRIPTION/APPLICATION	ORDER CODE
<b>BRAKE</b>			
B-lever 225.2	13	Polished lever, hole-Ø 8.1 mm for mirror	0122000
B-lever 225.4	16	Polished lever, hole-Ø 8.1 mm for mirror	0122020
<b>CLUTCH</b>			
C-lever 225.52	13	Polished lever, hole-Ø 8.1 mm for mirror	0122110
C-lever 225.54	16	Polished lever, hole-Ø 8.1 mm for mirror	0122130

Technical data: Stroke | 12 mm



### THROTTLE TWIST GRIP WITH MECHANICAL BRAKE 233

Single cable pulley throttle grip with mechanical brake lever. The throttle cable guide is open to enable external cable attachment. Folded and polished alloy lever.

MODEL	DESCRIPTION/APPLICATION	ACCESSORIES	ORDER CODE
Throttle twist grip 233.2.8	Housing painted black, grip black, folded and polished alloy lever. Suitable for Batavus, Hercules, Kreidler, Puch and Zündapp models.	Barrel, nipple and solder nipple	2100541

Technical Data: Cable pull | throttle 22 mm at a rotation of 75°, brake 18 mm



### THROTTLE TWIST GRIP WITH MECHANIC BRAKE 273

Straight pulley throttle twist grip with brake lever blade, one cable pull (possibility for outer attachment), black painted housing with supporting hole Ø 6.5 mm or adjusting screw for cable, polished alloy lever or fibre reinforced lever blade with or without pull back spring, sliding clamp for screwing or for solder nipple.

MODEL	DESCRIPTION/APPLICATION	ACCESSORIES	ORDER CODE
Throttle twist grip 273.6.8	Black housing with thread for brake light switch, sliding clamp, PUCH	Barrel, nipple	0123953
Throttle twist grip 273.6.8	As above, but without accessories	-	0123954

Technical data: Cable pull | throttle 21 mm at a rotation of 104°, brake 18 mm



### THROTTLE TWIST GRIP 307

Outer pulley throttle twist grip, single cable pull, straight cable up to 38 mm stroke, polished aluminium housing with trap door cover and adjusting screw for twist regulation, cable protection cover.

MODEL	DESCRIPTION/APPLICATION/VERWENDUNG	ACCESSORIES	ORDER CODE
Throttle twist grip 307.1	For general using	Solder nipple, grub screw, cable protection cover	0125600 <b>B</b>

Technical data: Total stroke | 46 mm at a rotation of 115° for handlebars Ø 22 mm and 7/8"



### THROTTLE TWIST GRIP 309

Throttle twist grip, one cable pull, with big rotation, two part housing of reinforced poly-carbon, protective sleeve.

MODEL	DESCRIPTION/APPLICATION	ACCESSORIES	ORDER CODE
Throttle twist grip 309.1	With grip "Street", SIMSON, SACHS, KTM, ZÜNDAPP	Cable support, cap, solder nipple	0126003

Technical data: Total stroke | 50 mm at a rotation of 213°





### THROTTLE TWIST GRIP 314

Motocross throttle twist grip with single cable, parallel pull. DUO-settings (Motocross or Enduro). Cable routed over roller for ease of pull. Black reinforced poly carbon housing, pro-grid rubber grip, quick and easy cable change, without removing housing. Can be changed to enduro setting.

MODEL	DESCRIPTION/APPLICATION	ACCESSORIES	ORDER CODE
Throttle twist grip set 314/029	In Motocross setting, with matching left grip	Solder nipple, rubber cable cover	0730218
Throttle twist 314	In Motocross setting without matching left grip	Solder nipple, rubber cable cover	0126386

Technical data: Total stroke | 48 mm at a rotation of 103°/91°



### ELECTRIC THROTTLE TWIST GRIP 317

Housing made of glass-fibre reinforced plastics for tube-Ø 22 mm. Overall length 150 mm, max. current-carrying capacity 1 Watt, resistor and range of control of the potentiometer see below. Outer diameter of connection cable-Ø 6 mm, cable up to 3 sees.

MODEL	DESCRIPTION/APPLICATION	ORDER CODE
Throttle twist grip/ Poti 317.2	5 kOhm-potentiometer, working rate 0-5 kOhm, cable length 800 mm	0026471
Throttle twist grip/ Poti 317.4	5 kOhm-potentiometer, working rate 0-5 kOhm, cable length 1800 mm	2101014
Throttle twist grip/ Poti317.9	5 kOhm-potentiometer, working rate 0-5 kOhm, cable length 225 mm, with Molex-plug, for MuZ-Scooter "Charly"	2101015

Technical data: Rotation angle 75°

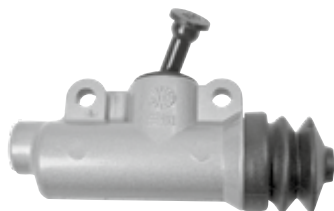

### MASTER BRAKE CYLINDER 700

Master brake cylinder for foot controlled rear disc brakes, tubing fitting M10x1 to the brake calliper, without brake fluid reservoir, fitting for tubing connection to an external brake fluid reservoir.

MODEL	PISTON Ø IN MM	DESCRIPTION/APPLICATION	ORDER CODE
Master brake cylinder 700.33	16	Chrome painted housing, EML, KTM	0131411

Technical data: Stroke | 12 mm

SPARE PARTS AND  
ACCESSORIES

# ORIGINAL SPARE PARTS



THE ORIGINAL ACCESSORIES AND SPARE PARTS ARE MANUFACTURED IN ORIGINAL MAGURA QUALITY - LONGEVITY AND PRECISION AS WELL AS PERFECT FITMENT HAVE CONVINCED MANY PASSIONATE TECHNICIANS AND ENSURE THAT WORKING ON YOUR MOTORCYCLE IS SIMPLE AND EFFECTIVE.





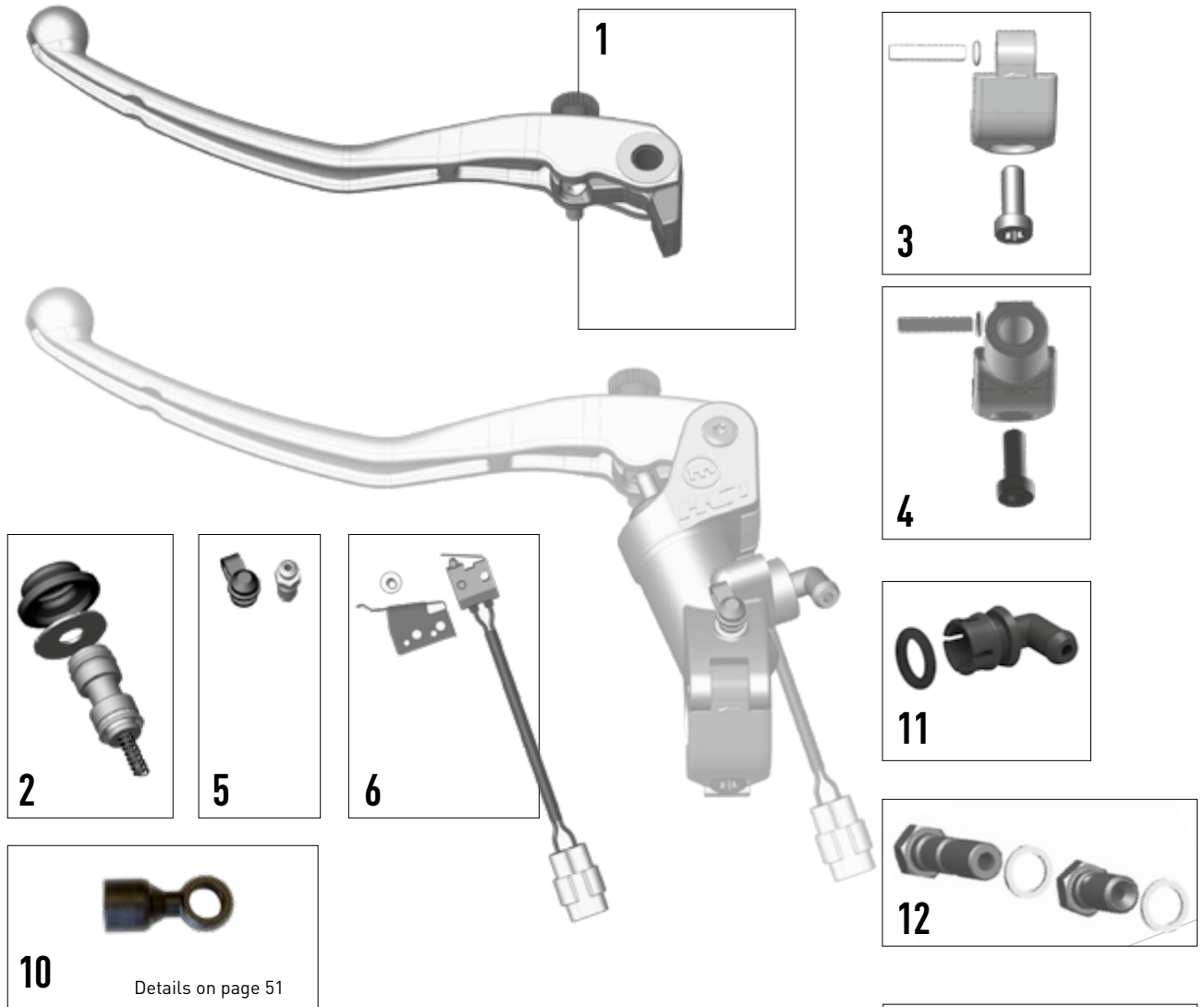

POSITION	DESCRIPTION/APPLICATION	ORDER CODE
1	Clutch lever assembly long black L = 180 mm	2701156
	Clutch lever assembly long silver L = 180 mm	0722112
	Clutch lever assembly short black L = 155 mm	2702082
2	Piston kit Ø12 mineral oil	0723234
	Piston kit Ø13 mineral oil	0722110
	Piston kit Ø12 DOT	0722211
	Piston kit Ø13 DOT	0722210
3	Piston kit Ø16 DOT	0722209
	Mounting bracket	2701161
	Mirror mounting bracket M10 x 1,25	2701162
5	Bleeding valve M5 x 0,8	0722214
6	Start safety switch	2701168
7	Clutch reservoir 9 ml flange mount for mineral oil (compatible with HYMEC)	2700787
8	Clutch reservoir 9 ml remote mount for mineral oil	2700492
9	Clutch reservoir 9 ml remote mount for DOT	2700491
10	Radial Pressure Line Adapter	2700499
	Adapter converts banjo ring from axial to radial connection avoiding the requirement for a new brake or clutch pressure line. Suitable for brake and clutch applications Suitable for application with MAGURA HYMEC pressure lines	
11	Socket with O-Ring for DOT	2701678
	Socket with O-Ring for mineral oil	2701677
12	Banjo Connector M10 x 1	0721786
	Double Banjo Connector M10 x 1 Includes gasket washers	0721789

**SERVICE**

To obtain the full performance from your HC master you will need to return it to MAGURA or to a certified service partner to have it serviced. We recommend a service every 100,000 km or 10 years.

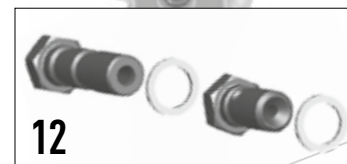
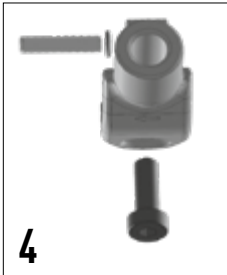
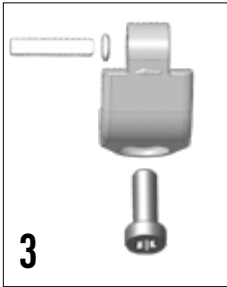

POSITION	DESCRIPTION/APPLICATION	ORDER CODE
1	Brake lever assembly long black L = 180 mm Brake lever assembly long silver L = 180 mm	2701157 0722202
2	Brake lever assembly short black L = 155 mm	2701158
3	Mounting bracket	2701161
4	Mirror mounting bracket M10 x 1,25	2701162
5	Bleeding valve M5 x 0,8	0722214
6	Brake light switch	0722213
7	Brake reservoir 16 ml flange mount for single calliper brake systems	2700786
8	Brake reservoir 36 ml remote mount for double calliper brake systems	2700488
9	Brake reservoir 9 ml remote mount for single calliper brake systems	2700490
10	Radial Pressure Line Adapter Adapter converts banjo ring from axial to radial connection avoiding the requirement for a new brake or clutch pressure line. Suitable for brake and clutch applications Suitable for application with MAGURA HYMEC pressure lines	2700499
11	Socket with O-Ring for DOT	2701678
12	Banjo Connector M10 x 1 Double Banjo Connector M10 x 1 Includes gasket washers	0721786 0721789

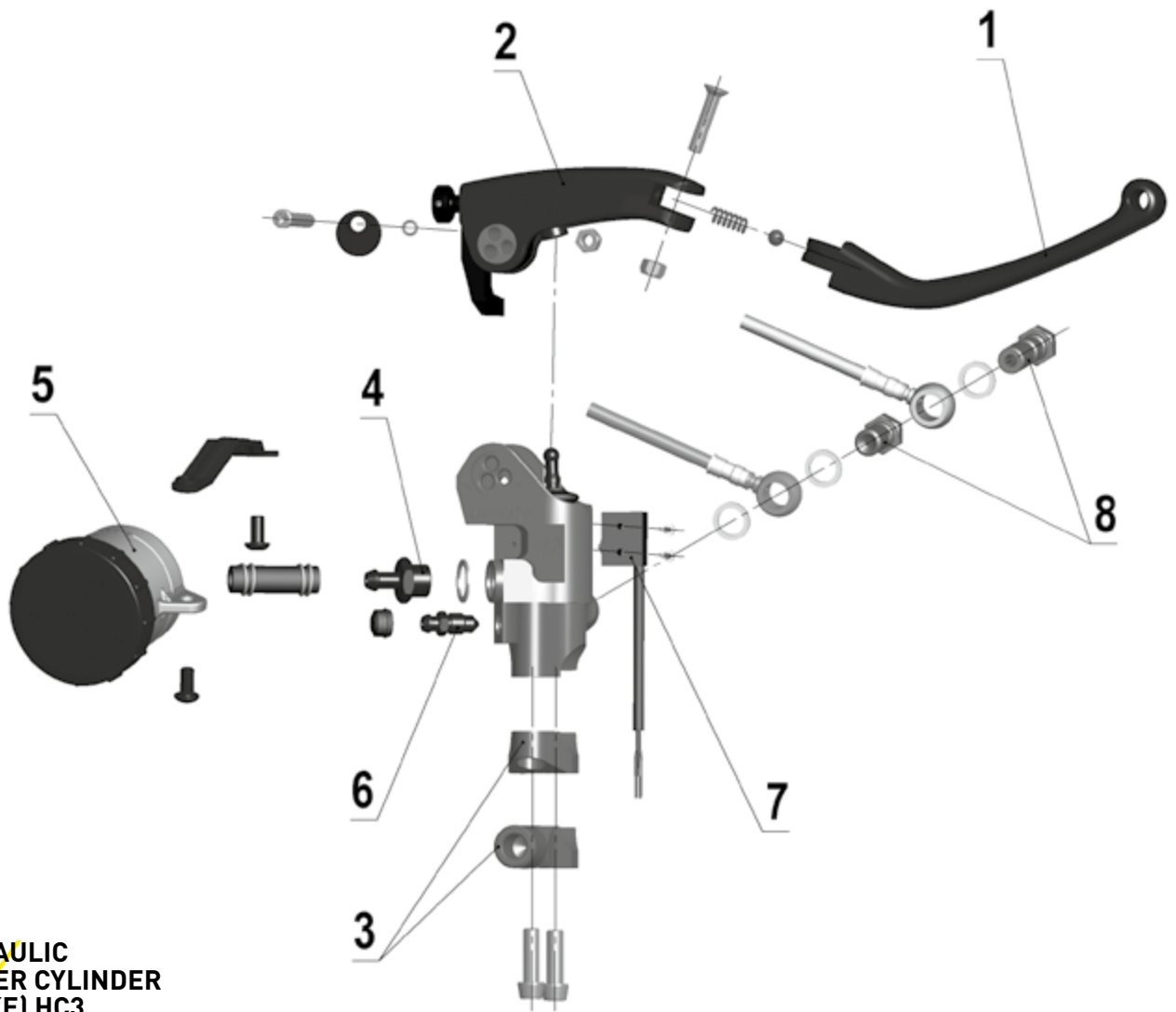

HYDRAULIC  
MASTER CYLINDER  
(BRAKE) HC3

HYDRAULIC  
MASTER CYLINDER  
(CLUTCH) HC3

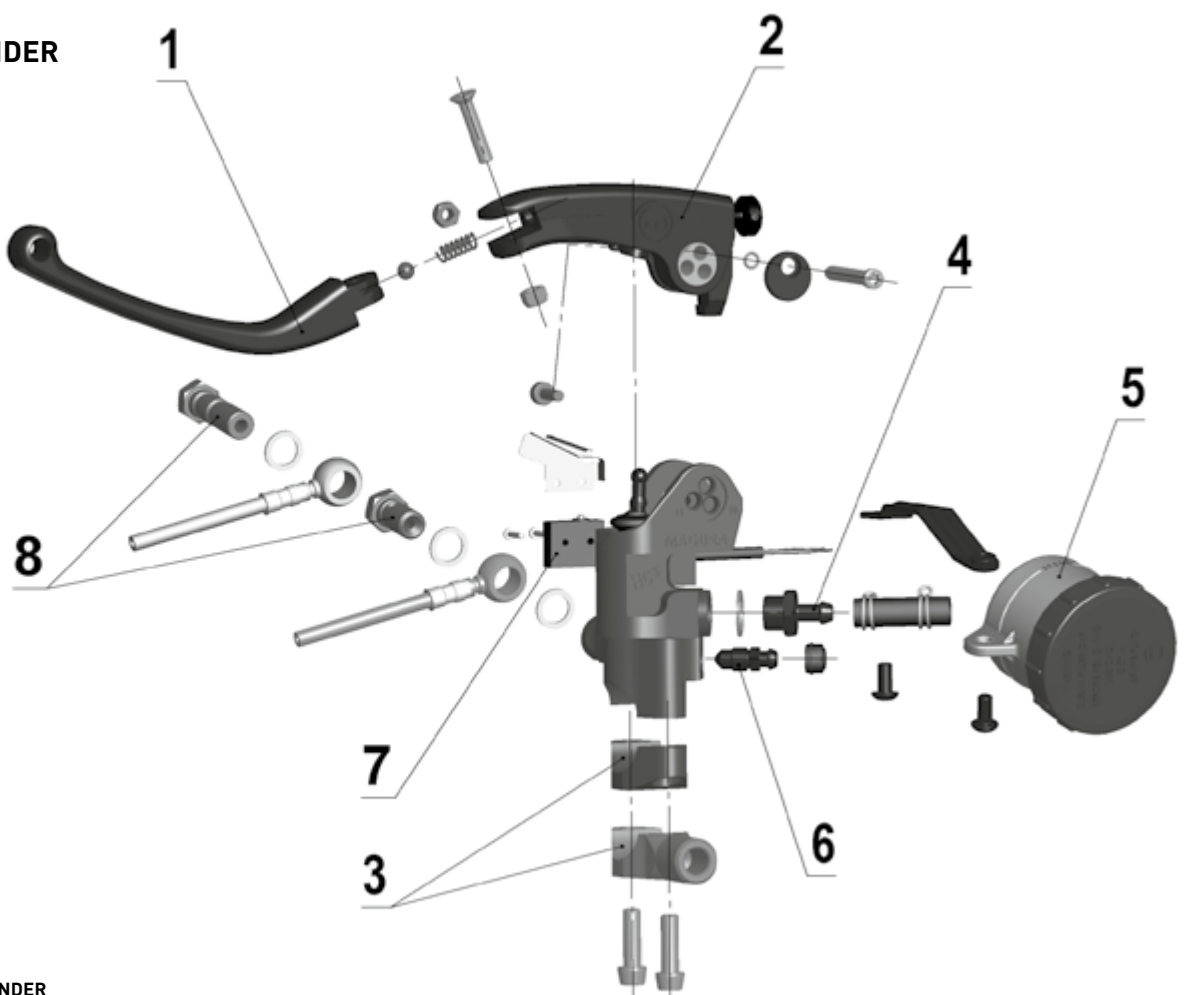



## SERVICE

To obtain the full performance from your HC master you will need to return it to MAGURA or to a certified service partner to have it serviced. We recommend a service every 100,000 km or 10 years.

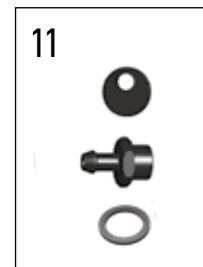

## HC3 | OPTIONAL AND SPARE PARTS



POSITION	DESCRIPTION/APPLICATION	ORDER CODE
1	Folding Lever Blade long L = 193 mm	2700493
	Folding Lever Blade short L = 165 mm Includes retaining bolt, nut, spring and ball	2700494
2	Lever Base – Brake	2700496
	Lever Base – Clutch Includes reach adjust, bracket, piston activation rod, bellows and titanium lever securing bolt with self locking nut and o-ring	2700495
3	Clamp	2700484
	Mirror Clamp	2701393
	Mirror Clamp Gold M10 x 1,25	2700485
	Mirror Clamp Black M10 x 1,25 Includes 2 titanium clamp screws	2701392
4	Reservoir Connector Includes gasket washer	2700486
5	Reservoir Radial HC Brake 36 ml	2700488
	Reservoir Radial HC Brake 9 ml	2700490
	Reservoir Radial HC Clutch 9 ml DOT	2700491
	Reservoir Radial HC Clutch 9 ml Mineral Oil	2700492
	Suitable for use with HC <sup>1</sup> , HC <sup>3</sup> and Radial 195. Includes hose, security hose clamp (x2), retaining bracket and bolts.	
6	Bleed Nipple Includes dust cover	0720527
7	Switch-Kit Brake	0722213
	Switch-Kit Clutch, black, 2 cable exit	2700487
	Switch-Kit Clutch, turquoise, 3 cable exit Securing screws are included with the switches. Please order the colour switch originally used on your original master cylinder	2701532
8	Banjo Connector M10 x 1	0721786
	Double Banjo Connector M10 x 1 Includes gasket washers	0721789
9	Remote Brake Lever Adjuster On the fly lever reach adjustment for race track use.	2700497
10	Radial Pressure Line Adapter Adapter converts banjo ring from axial to radial connection avoiding the requirement for a new brake or clutch pressure line. Suitable for brake and clutch applications Suitable for application with MAGURA HYMEC pressure lines	2700499
11	Colour-Kit, HC3, black	2701394
	Colour-Kit, HC3, red	2701395
	Colour-Kit, HC3, green	2701397
	Colour-Kit, HC3, blue	2701398
	Colour-Kit, HC3, silver	2701399

**167 HYMEC  
MASTER  
CYLINDER**

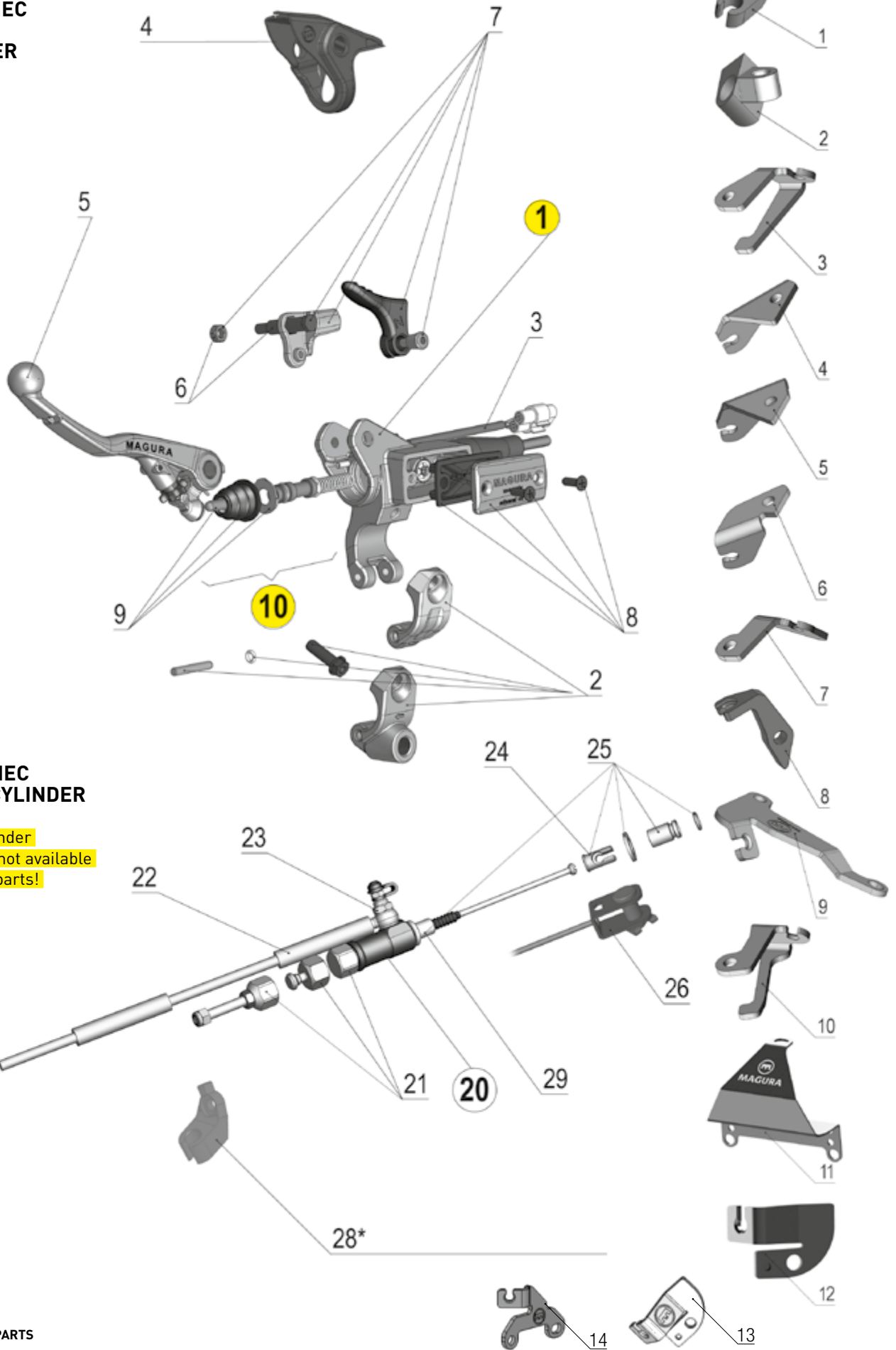

**167 HYMEC  
SLAVE CYLINDER**

Slave cylinder seal-kits not available as spare parts!

## 167 HYMEC SPARE PARTS

POSITION	MODEL	ORDER CODE
1	Master cylinder*	Seite 22/23
2	Clamp black	<b>2700176</b>
	Clamp black for threaded mirror mount M10 x 1.25 mm	<b>2700177</b>
	Clamp black for threaded mirror mount M10 x 1.5mm (BMW F 800 HYMEC) All supplied with fitting pin and retaining bolt	<b>2700385</b>
3	Clutch switch	<b>0723187</b>
	Clutch switch BMW F 800 HYMEC	<b>2700384</b>
4	Protection cover for lever without choke lever	<b>0723163</b>
	Protection cover for lever with choke lever	<b>0723202</b>
5	Lever Off-Road clutch silver long L = 146 mm	<b>0723290</b>
	Lever Off-Road clutch silver short L = 123 mm	<b>0723121</b>
	Lever Street clutch black L = 163 mm	<b>0723296</b>
	Lever Street clutch silver L = 163 mm	<b>2700244</b>
6	Screw for lever without deco	<b>0723115</b>
7	Deco lever black	<b>0723189</b>
	Hot start lever red	<b>0723188</b>
8	Reservoir cover for mineral oil use with bellow and screws	<b>2700501</b>
	Reservoir cover for DOT use with bellow and screws	<b>2700215</b>
9	Bellows with push rod and washer	<b>0723116</b>
10	Master piston-Ø 9,5 mm mineral oil	<b>0723184</b>
	10,5 mm mineral oil	<b>0723185</b>
	12 mm mineral oil	<b>2700489</b>
20	Slave cylinder	Seite 28/29
21	HYMEC slave rear cap kit includes STANDARD, REARMOUNT and REARMOUNT VARIO cap options	<b>2100018</b>
22	Pressure line kit CARBON with accessories L = 1.120 mm	<b>0722137</b>
	Pressure line kit CARBON with accessories L = 1.045 mm	<b>0722138</b>
	Pressure line kit ARAMID (cut to size) with accessories L = 1.500 mm	<b>0722679</b>
23	Banjo bolt with bleeding valve for carbon tubings M 6x16.5 mm	<b>0722136</b>
24	Nipple Adapter Kit includes 11 and 14 mm attachment nipple adapter	<b>2701674</b>
25	HYMEC- Slave attachment kit includes 12 and 15 mm 2-stroke adapter sleeve with o-ring, spacer washer and nipple adapter.	<b>2701697</b>
26	Clutch activation arm adapter (suitable for Suzuki motorcycles)	<b>2701695</b>
28	1. Mounting adapter Suzuki RM-Z 250, Model year 2004-2008	<b>2701682</b>
	1. Mounting adapter Kawasaki KXF 250, Model year 2004-2008	<b>2701682</b>
	2. Mounting adapter Honda CRF 450 R, Model year 2004	<b>2701681</b>
	3. Mounting adapter Kawasaki KX 450 F, Model year 2006-2009	<b>2701685</b>
	4. Mounting adapter Honda CRF 450 R, Model year 2005-2009	<b>2701686</b>
	5. Mounting adapter Suzuki RM-Z 250, Model year 2009-2011	<b>2701683</b>
	6. Mounting adapter Suzuki RM-Z 450, from Model year 2008	<b>2701684</b>
	7. Mounting adapter Kawasaki KX 450 F, Model year 2009-2014	<b>2701687</b>
	8. Mounting adapter Honda CRF 250 F, Model year 2014-2017	<b>2701690</b>
	9. Mounting adapter Honda CRF 450 R, Model year 2015-2016	<b>2701692</b>
	10. Mounting adapter Kawasaki KX 450 F, Model year 2015	<b>2701691</b>
	11. Slave Protection Kawasaki KX 450 R, Model year 2016-2018	<b>2701694</b>
	12. Mounting adapter Honda CRF 450 R, Model year 2017	<b>2701696</b>
	13. Mounting adapter Honda CRF 450 R, from Model year 2019	<b>2701898</b>
14. Mounting adapter Suzuki RMZ 250, from Model year 2020	<b>2701968</b>	
30	MAGURA-Blood 100 ml - F/NL	<b>2700818</b>
	MAGURA-Blood 1 l - F/NL	<b>2700819</b>
	MAGURA-Blood 100 ml - D/E	<b>0721820</b>
	MAGURA-Blood 1l - D/E	<b>0721821</b>
31	Service-Kit HYMEC	<b>0722152</b>





# HUSQVARNA SPARE PARTS

## BRAKE MASTER CYLINDER

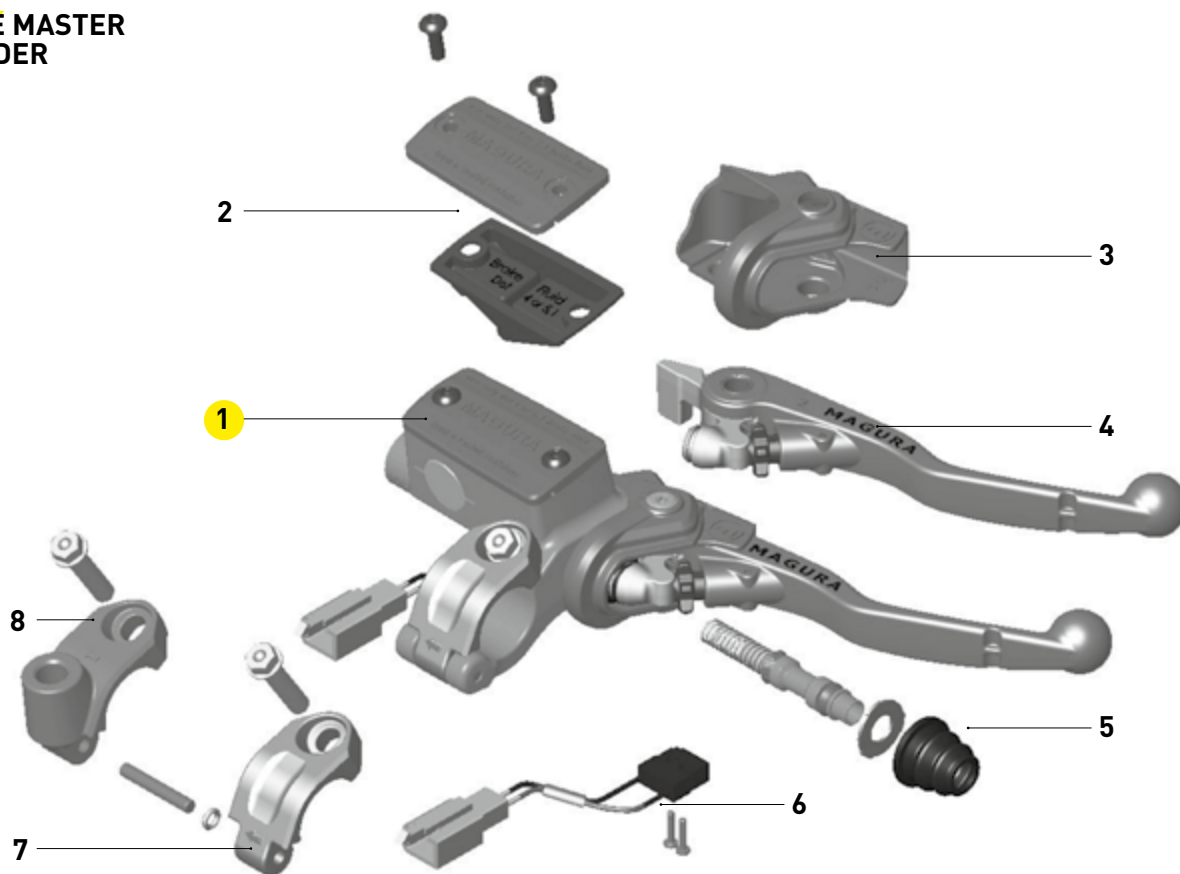

POSITION	DESCRIPTION	ORDER CODE
----------	-------------	------------

### BRAKE MASTER CYLINDER

1	Brake master cylinder 167 axial complete	2701753
2	Reservoir cover with bellow and screws	2701743
3	Protective cover for lever	2701754
4	Brake lever 167 silver L = 123 mm	2701742
5	Master piston 167 DOT Ø 9.5 mm	2701755
6	Brake light switch 167	2701744
7	Clamp silver 167	2701775
8	Clamp silver for mirror mount M10 x 1.25	2701756

### FRONT CALLIPER

1	Calliper front silver without pads	2701745
2	Bleed valve with dust cover	2701747
3	Banjo connector M10 x 1	2701749
4	Pad security pin with lock clip	2701748
5	Pad retaining spring kit	2701750
6	Front brake pad kit	2701746
7	Rep calliper piston and seals 24 mm	2701759
8	Rep kit calliper seals 24 mm	2701760
9	Floating calliper bellow kit	2701758

## FRONT CALLIPER

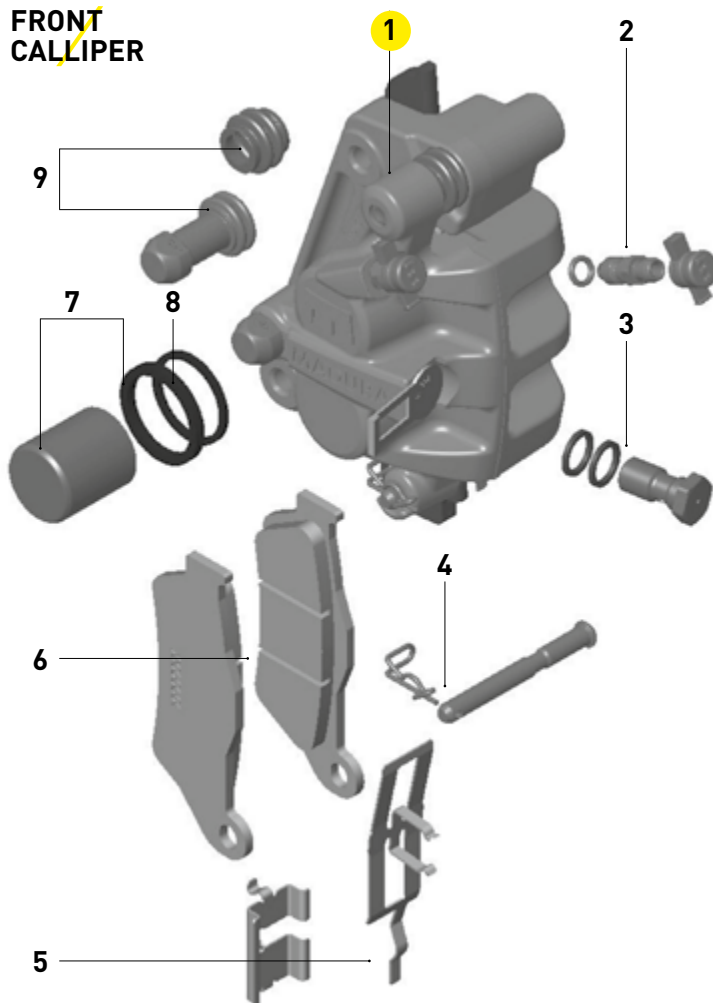

## REAR BRAKE MASTER CYLINDER

POSITION	DESCRIPTION	ORDER CODE
<b>REAR BRAKE MASTER CYLINDER</b>		
1	Rear brake master cylinder complete	2701761
2	Reservoir cover with bellows and breather	2701762
3	Hydraulic rear brake light switch	2701765
4	Banjo connector M10 x 1 for rear master	2701764
5	Rear master piston for DOT Ø 13 mm	2701763
<b>REAR BRAKE CALLIPER</b>		
1	Calliper rear without pads for Enduro models with axle Ø 20 mm (TE/FE)	2701767
1	Calliper rear without pads for Motocross Models with axle Ø 25 mm (TC/FC)	2701768
2	Rear brake pad kit	2701771
3	Rear pad retaining spring kit	2701772
4	Rear pad security pin with lock clip	2701748
5	Banjo connector with bleed valve	2701773
6	Rear floating calliper bellow kit	2701758
7	Rep kit calliper piston and seals	2701759
8	Rep kit calliper seals	2701760

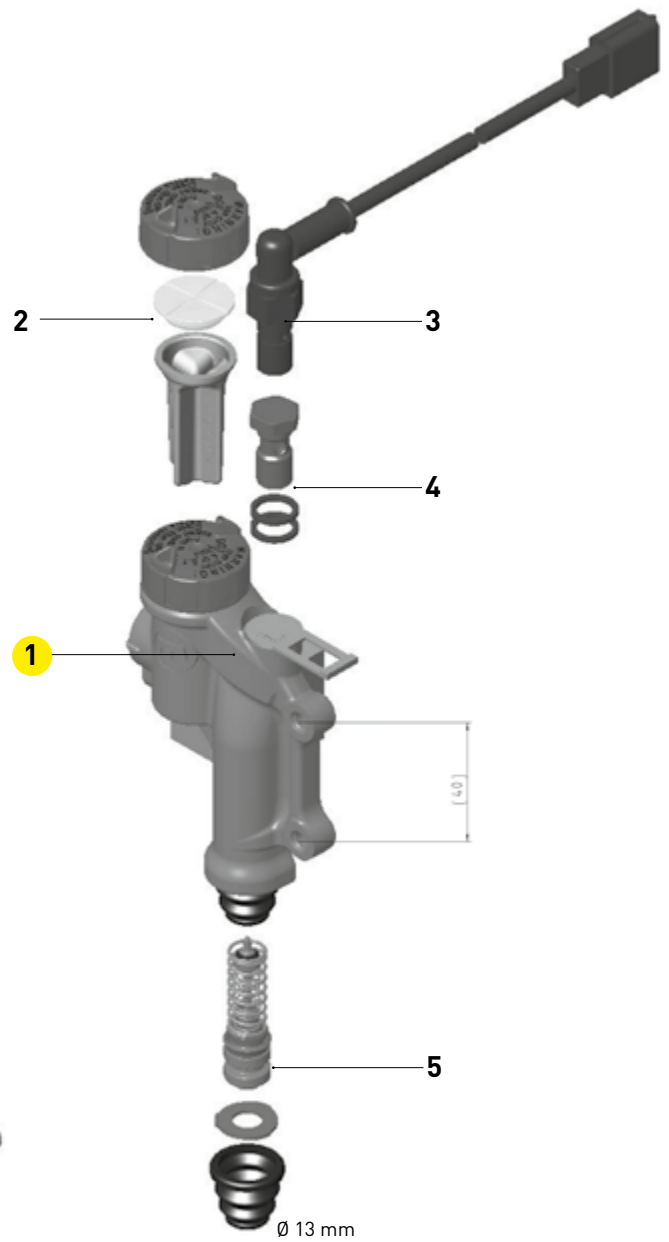

## REAR BRAKE CALLIPER

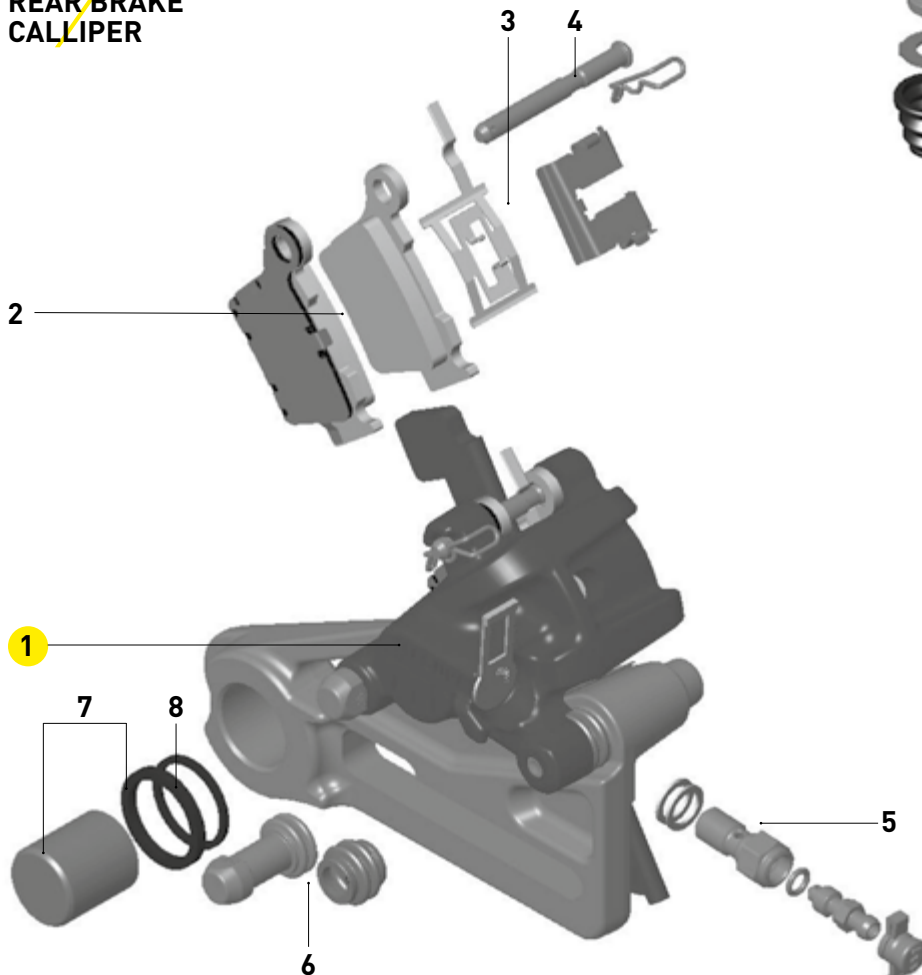

# HUSQVARNA SPARE PARTS

## BRAKE LINES

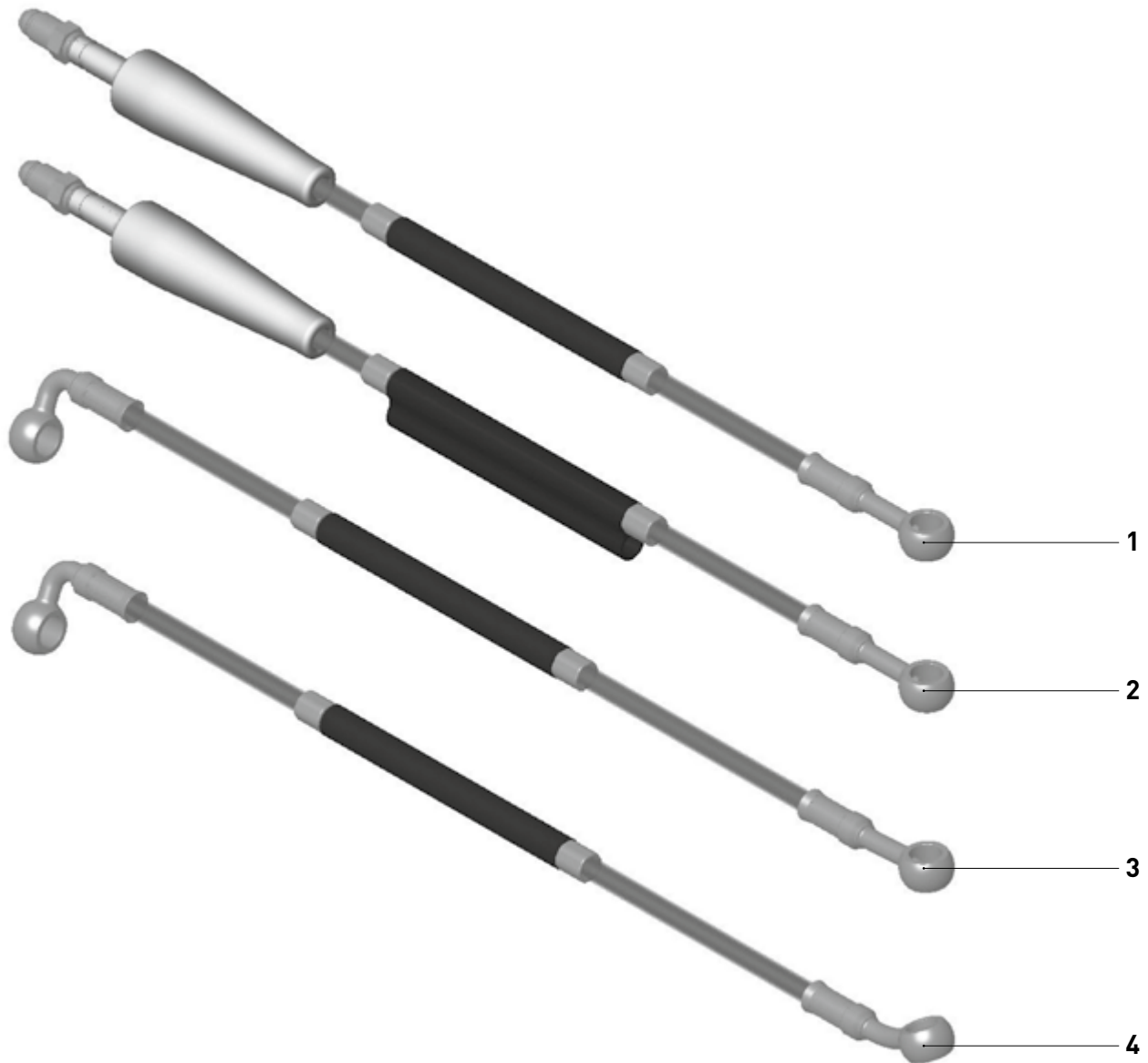

POSITION	MODEL	ORDER CODE
1	Brake line front Motocross (TC/FC)	2701752
2	Brake line front Enduro (TE/FE)	2701751
3	Brake line rear Motocross (Fitting 5° - TC/FC)	2701774
4	Brake line rear Enduro (Fitting 25° - TE/FE)	2701766



# 195 RADIAL MASTER CYLINDER

1



2



4



3 + 5 + 6

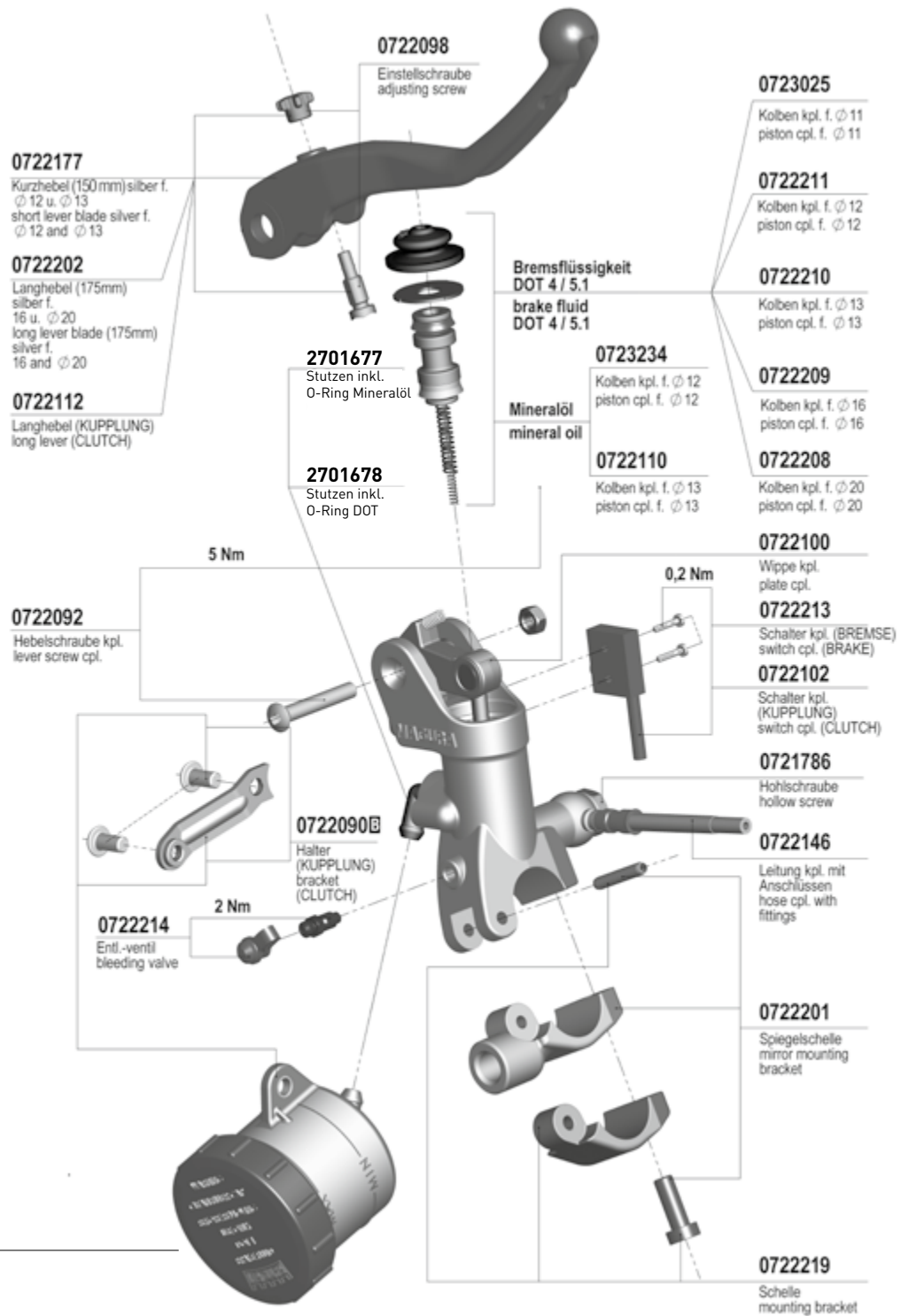

## RESERVOIRS

POSITION	MODEL	DESCRIPTION/APPLICATION	ORDER CODE
1	195 Brake reservoir	16 ml flange mount for single calliper brake systems	2700786
2	195 Brake reservoir	36 ml remote mount for double calliper brake systems	2700488
3	195 Brake reservoir	9 ml remote mount for single calliper brake systems	2700490
4	195 Clutch reservoir	9 ml flange mount for mineral oil (compatible with HYMEC)	2700787
5	195 Clutch reservoir	9 ml remote mount for mineral oil	2700492
6	195 Clutch reservoir	9 ml remote mount for DOT	2700491

## 167 CLUTCH MASTER CYLINDER

**0723202**

Schutzkappe  
protection cap

**2700244**

Extra lang kpl. l=163mm silber  
extra long cpl. l=163mm silver

**0723296**

Extra lang kpl. l=163mm schwarz  
extra long cpl. l=163mm black

**0723121**

Kurzhebel kpl. l=123mm  
short lever cpl. l=123mm

**0723290**

Langhebel kpl. l=146mm  
long lever cpl. l=146mm

**0723188**

Hebel kpl. (Heissstarthebel)rot  
lever cpl. (lever for hot start)red

**0723189**

Hebel kpl. (Dekohebel)schwarz  
lever cpl. (deco lever)black

**0723187**

Schalter kpl.  
(mit Stößel u. Schraube)  
switch cpl.  
(with ram and screw)

**2700384**

Schalter kpl.  
BMW-Stecker  
switch cpl.  
BMW connector

**0723115**

Bundschraube M5  
ohne Deko  
shouldered screw M5  
without deco

**0723116**

Balg (m. Druckstange u. Scheibe)  
bellows (with push rod and washer)

**0723184**

Kolben kpl.  $\varnothing$ 9,5 Mineralöl  
piston cpl.  $\varnothing$ 9,5 mineral oil

**0723185**

Kolben kpl.  $\varnothing$ 10,5 Mineralöl  
piston cpl.  $\varnothing$ 10,5 mineral oil

**2700489**

Kolben kpl.  $\varnothing$ 12 Mineralöl  
piston cpl.  $\varnothing$ 12 mineral oil

**2700181**

Kolben kpl.  $\varnothing$ 9,5 DOT  
piston cpl.  $\varnothing$ 9,5 DOT

**2700182**

Kolben kpl.  $\varnothing$ 10,5 DOT  
piston cpl.  $\varnothing$ 10,5 DOT

**0723118 B**

Schelle  
mounting bracket

**2700176**

Schelle schwarz  
mounting bracket black

**0723183 B**

Spiegelschelle  
mirror mounting bracket

**2700177**

Spiegelschelle schwarz  
mirror mounting bracket black

**2700501**

Deckel-Kit Mineralöl  
cap-kit mineral oil

**2700215**

Deckel-Kit DOT  
cap-kit DOT

## 167 BRAKE MASTER CYLINDER

**0723115**

Bundschraube M5  
shouldered screw M5

**0723114**

Kappe  
cap

**0723123**

Bremslichtschalter  
brake light switch

(2x)

**0723073**

Langhebel kpl. L=146mm  
long lever cpl. L=146mm

**0723292**

Kurzhebel kpl. L=123mm  
short lever cpl. L=123mm

**0723116**

Balg (m. Druckstange u. Scheibe)  
bellow (with push rod and washer)

**2701755**

Kolben kpl.  $\varnothing$ 9,5 DOT  
piston cpl.  $\varnothing$ 9,5 DOT

**0723071**

Kolben kpl.  $\varnothing$ 12,0 DOT  
piston cpl.  $\varnothing$ 12,0 DOT

**0723119**

Balg  
bellow

**0723118**

Schelle  
mounting bracket

# SPARE PARTS FOR 190 MASTER CYLINDER

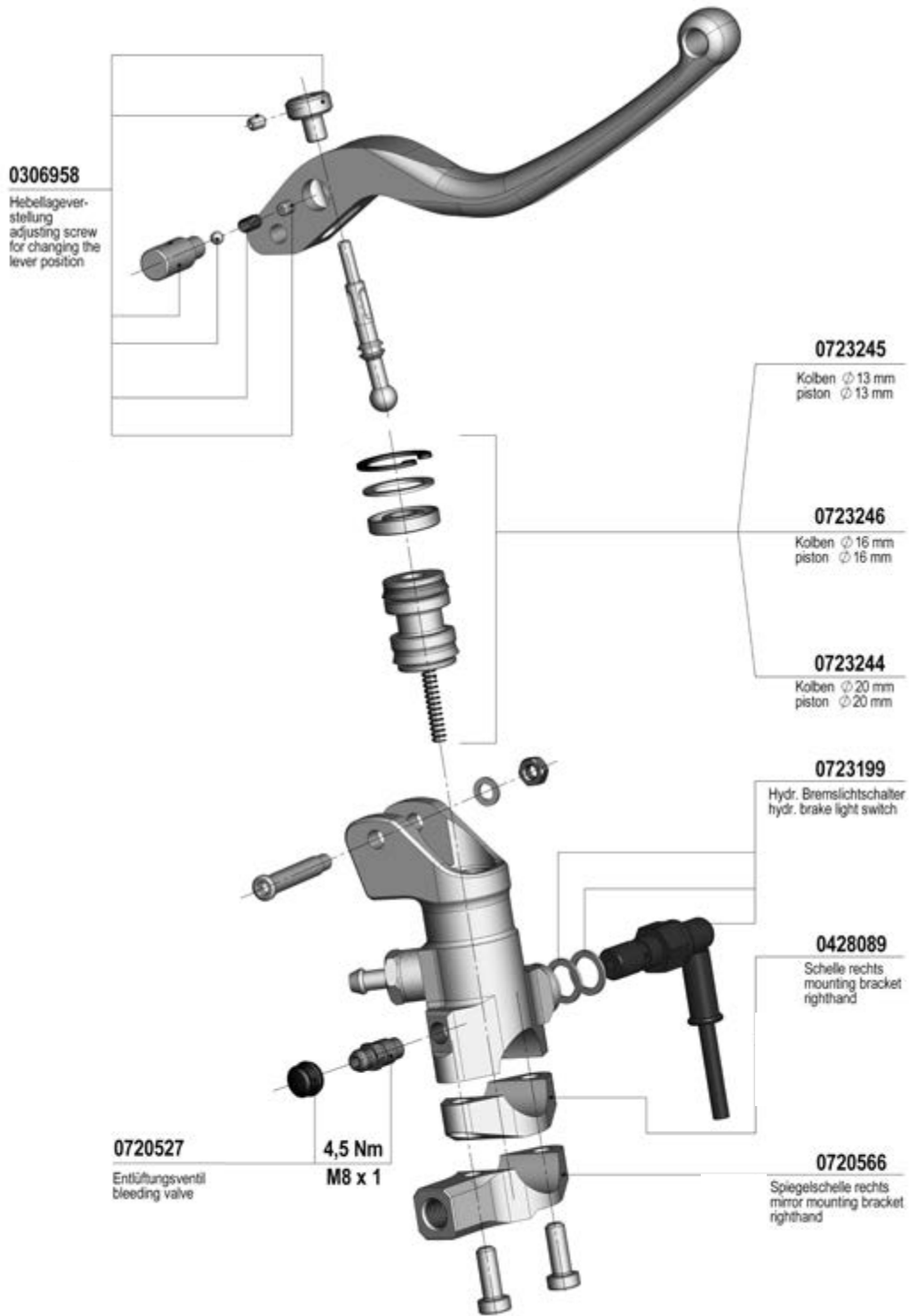



# 163 MASTER CYLINDER

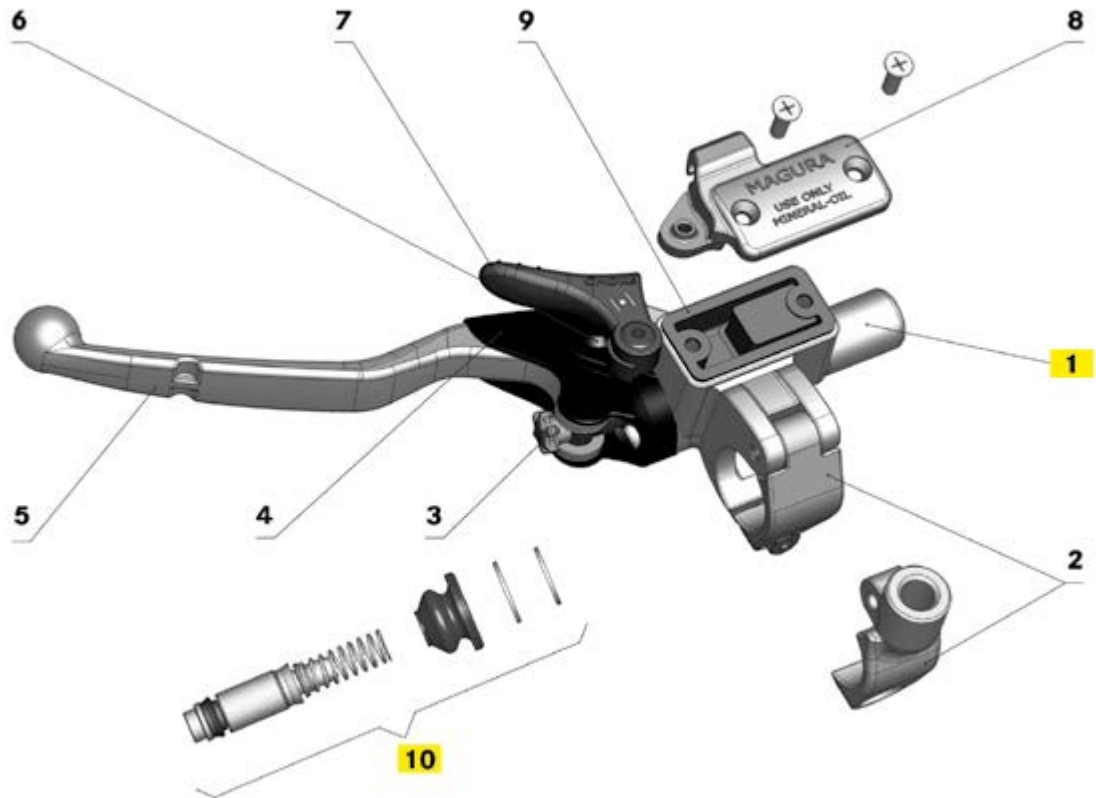

## 163 MASTER CYLINDER SPARE PARTS

POSITION	MODEL	ORDER CODE
1	Master cylinder - for replacement options see 167 master	Page 22/23
2	Clamp with spiral spin	0720546
	Clamp for threaded mirror mounting M10x1.25 mm	0720543
	Clamp schwarz for threaded mirror mounting M10x1.25 mm	0722026 ☒
3	Adjuster wheel for lever, red (packaging unit 10 pcs.)	0720572
4	Protection cover for lever	2701680
5	Long lever blade with accessories and coil spring l = 147 mm	0720598
	Short lever blade with accessories and coil spring l = 123.5 mm	0720600
	Special lever blade f. master cylinders with bigger space l = 152 mm	0722021
6	Screw for lever	0720504 ☒
7	Deco lever black	0720552
	Choke lever black	0722118
	Choke lever red	0722312
8	Cover without deco-/choke lever	0720544
	Cover with thread for deco lever	0720553
	Cover with hole for deco lever	0720559
	Cover for choke lever	0722139
	Cover black without deco-/choke lever	0720500 ☒
9	Reservoir membrane for mineral oil	0720560
	Reservoir membrane for DOT	2701679
10	Master piston Ø	
	9,0mm Mineral oil	0722027
	9,5mm Mineral oil	0720555
	10,5mm Mineral oil	0720499
	9,5mm DOT	0723293
10,5mm DOT	0720525	

## 750 RADIAL SUPERMOTO

320-330 mm 1 brake calliper

Brake pad  
Sinter-Race  
0723024



## 770 RADIAL SUPERMOTO

270 mm 2 brake callipers

Brake pad  
Sinter-Race  
0722689



**HYMÉC**  
FOR HARLEY

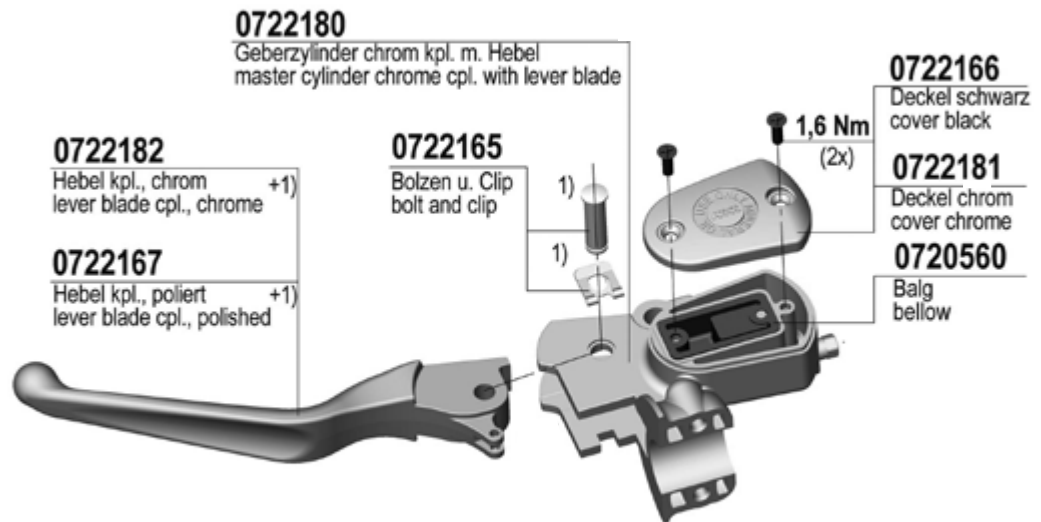

### 0722184 Sportster

Zubehör  
accessory



### 0722136

Hohlschraube kpl.  
banjo screw cpl.

6 Nm

### 0722160 Sportster

Nehmerzylinder kpl.  
slave cylinder cpl.

### 0722161 Sportster

Leitung kpl. l=1450mm  
hose cpl.

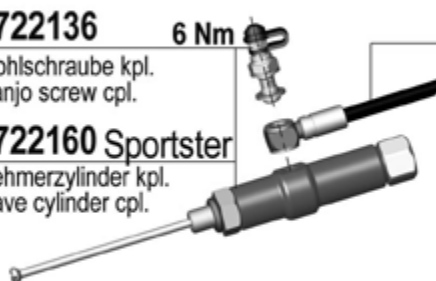

## HYDRAULIC ACCESSORIES

MODEL	DESCRIPTION/APPLICATION	ORDER CODE
<b>CARBON TUBINGS</b>		
Carbon tubing kit	For HYMEC, length 1,045 mm	0722138
Carbon tubing kit	For HYMEC, length 1,120 mm	0722137
Banjo bolt	With bleeding valve M6x16.5 mm for HYMEC	0722136
<b>STEEL BRAIDED HOSES</b>		
Steel braided hose	For MAGURA Brake System 750.1, length 1,185 mm, DOT	0722146
1 Steel braided hose	Length 1,025 mm	0722004
2 Steel braided hose	KTM 4-Stroke Racing, length 975 mm	0722005
Steel braided hose	KTM LC8, length 1,140 mm	0722015
Steel braided hose	KTM LC4, length 1,025 mm	0722016
Steel braided hose	Husaberg, length 1,020 mm	0722023
Steel braided hose	KTM 250/380, length 970 mm	0722057
1 Steel braided hose	KTM 2-Stroke 125/200, length 970 mm	2701665
6 Banjo bolt	To fix the clutch tubing with thread M10x1, inclusive bleeding screw	0720505
5 Banjo bolt	For single brake line, without bleeding valve, M10 x1	0721786
Banjo bolt	For two line fittings, M10 x1	0721789
<b>PA-TUBINGS</b>		
4 PA-tubing kit	Length 1,025 mm	0131890
3 PA-tubing kit	With protection tube, length 1,045 mm	0131893
PA-tubing kit	KTM 65/85 SX, with protection tube, length 910 mm	0131894
PA-tubing kit	KTM 4-Stroke Racing, length 975 mm	0720551
PA-tubing kit	For HYMEC, length 1,500 mm, shortable	0722679
7 Olive/packing unit 10 pcs.	To fix the clutch tubing in the sleeve screw 0720548	0720308
Banjo bolt	For HYMEC-versions with PA-tubing	0722136
8 Hose Kit EPDM – Pack of 5	Extension hose for <b>DOT</b> fluid use to connect a MAGURA brake fluid reservoir to our HC1 and HC3 radial master cylinders. Length 400 mm	2701521
Hose Kit NBR - Pack of 5	Extension hose for <b>mineral oil</b> use to connect a MAGURA clutch fluid reservoir to out HC1 and HC3 radial master cylinders. Length 400 mm	2702080
<b>SERVICE-KITS</b>		
9 Service-Kit HYMEC	Contains everything you need to refill MAGURA's HYMEC	0722152
10 MAGURA-Blood 100 ml - F/NL	High quality hydraulic mineral based oil for HYMEC	2700818
10 MAGURA-Blood 1 l - F/NL	High quality hydraulic mineral based oil for HYMEC	2700819
10 MAGURA-Blood 100 ml - D/E	High quality hydraulic mineral based oil for HYMEC	0721820
10 MAGURA-Blood 1l - D/E	High quality hydraulic mineral based oil for HYMEC	0721821
11 MAGURA Royal Blood 100 ml	High quality hydraulic mineral based oil for hydraulic clutch systems	0721630
11 MAGURA Royal Blood 1 l	High quality hydraulic mineral based oil for hydraulic clutch systems	0721631

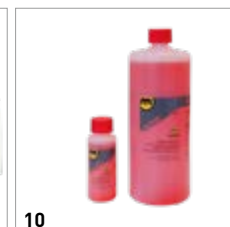
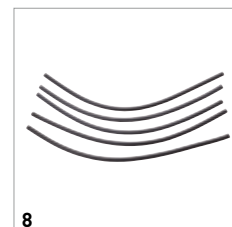
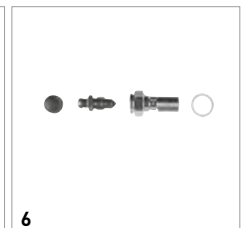
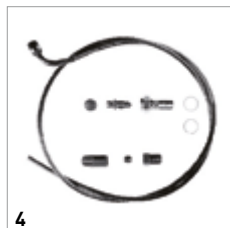
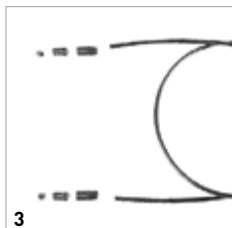





## MAGURA ANTIBUG: KEEPING YOUR VISION CLEAR

PIECE	DESCRIPTION/APPLICATION	ORDER CODE
1	With its new Antibug visor cleaning sponge, MAGURA has a chemical-free alternative to keep your helmet visor free from insects and dirt.	2701163

## SWITCHES

MODEL	DESCRIPTION/APPLICATION	ORDER CODE
1 Switch 558.61	On in paused position, white pusher, micro-switch with spring, for thread 1/4"	0128496
2 Switch 558.12	Off in paused position, black pusher, for thread 1/4", start safety switch for MAGURA-model 163	0128500
3 Switch 558.51	On in paused position, pluggable, blue pusher, for MAGURA-models 116/117, for Suzuki and Simson scooters	0128510
4 Switch 163 B	For Yamaha XT 660 – HYMEC, cable length 620 mm	0306938
5 Switch 558.34	On in paused position, white pusher, for thread M8x1	2701689
Switch 701	Hydraulic brake light switch	0723199
6 Protection cover 558	For all switch models 558 small inner-Ø 3.6/ big inner-Ø 10.5	2701676
7 Clutch switch 163	KTM-models LC 4 from 2003 and LC 8, for thread 1/4", cable length 550 mm	0722014
8 Switch 195	For RADIAL 195 Clutch	0722102
9 Switch 195	For RADIAL 195 Brake, cable length 400 mm	0722213
Switch HC3	Switch Kit Brake Switch Kit Clutch - Start safety switch, black, 2 cables Switch Kit Clutch - Start safety switch, turquoise, 3 cable exit Securing screws are included with the switches. Please order the colour switch originally used on your original master cylinder	0722213 2700487 2701532
10 Clutch switch 167	For MAGURA model 167 (Clutch)	0723187
11 Clutch switch 167	For BMW-HYMEC (Clutch)	2700384
Brake light switch 167	For MAGURA model 167 (ATV-Brake), cable length 760 mm	0723197
Brake light switch 167	For MAGURA model 167, cable length 400 mm	0723123

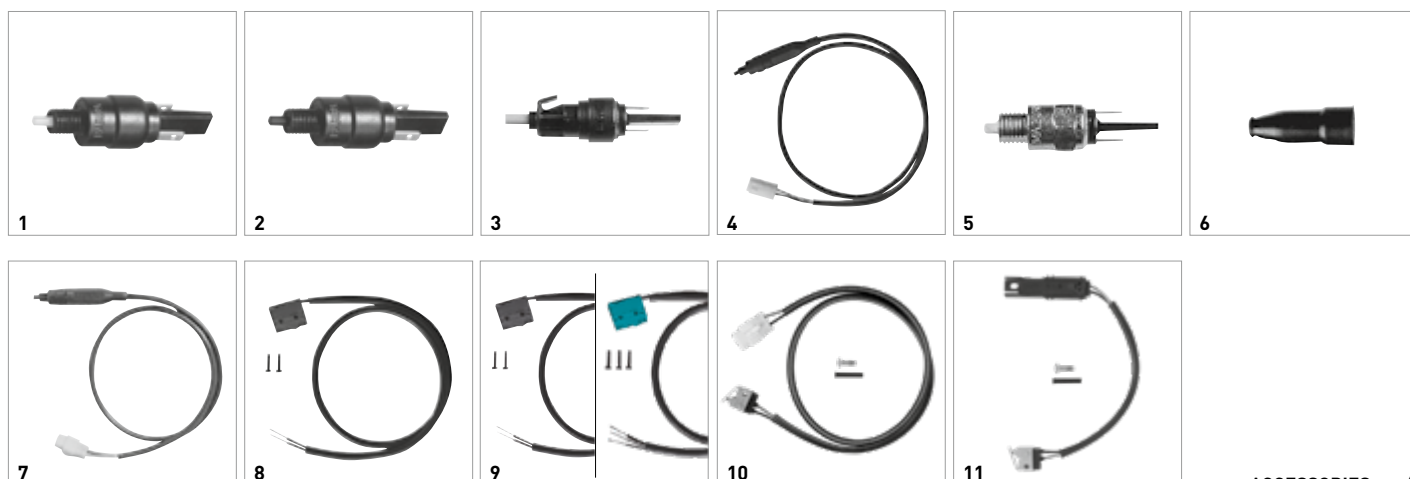

## GRIPS, PAIRS OF GRIPS



MODEL	DESCRIPTION/APPLICATION	LENGTH IN MM	ORDER CODE
1	150 sz*/151 sz* for tube-Ø 25/22	129	0720850
2	125 sz* for tube-Ø 25/22	125	0720851
3	312 szw* for tube-Ø 25/22	125	0720853
4	250 ksz* for tube-Ø 25/22	114	0720854
5	289 tsz* for tube-Ø 25/22	126	0720855
5	250 ksz* for tube-Ø 25, Wulst-Ø 48	124	2701673
6	316 ksz* for tube-Ø 25/22	116	0720856
7	DAB6 sz for tube-Ø 27,5	116	0720920
8	DAB6 sz for tube-Ø 27,5	121	2701492
9	125 sz* for tube-Ø 25/22	125	2701489
10	306 sz* for tube-Ø 25/22	129	2701490
11	270 ksz* for tube-Ø 25/22	129	2701491

\*  
sz | rubber black  
szw | rubber black, soft  
ksz | fibre reinforced black  
tsz | thermoplastic  
elastomer, black

## SOLDERNIPPLE, SOLDER NIPPLE BARRELS





PACKING UNIT	DIMENSIONS IN MM			ORDER CODE
	Ø WIDTH	LENGTH	HOLE	
<b>SOLDER NIPPLES BARREL</b>				
10	9/8	15,5	2,5	2701504
10	10	11,6	2,3	2701505
<b>SOLDER NIPPLES</b>				
10	6/3,5	13	2,3	2701506
10	6/3,5	8	2,3	2701507
10	6/3,5	8	2,0	2701508











## NIPPLE ASSORTMENT

DESCRIPTION/APPLICATION	ORDER CODE
A well sorted selection of 100 various screw nipples, solder nipples and nipple barrels in a very comfortable plastic box. "A need in biker's garage!"	0736500

## SCREW NIPPLES

	PACKING UNIT	DIMENSIONS IN MM			ORDER CODE
		Ø WIDTH	LENGTH	HOLE	
	10	8	8,5	2,5	2701509
	10	6	9	2,5	2701510
	10	5	9,5	2	2701511
	10	8	15	2,3	2701512
	10	5	7,5	2	2701513

## ADJUSTING SCREWS

	PACKING UNIT	Ø WIDTH	DIMENSIONS IN MM		ORDER CODE	ORDER CODE
			LENGTH	HOLE		
<b>UNSLOTTED ADJUSTING SCREW, WITH KNURLED METAL NUT</b>						
	1	M6	32	6,8	2,8	2701515
	1	M6	41	6,1	2,5	2701516
	1	M6x0,75	31	6,5	3	2701517
	1	M10x1	44	11	6,2	2701523
<b>SLOTTED ADJUSTING SCREW, WITH KNURLED METAL NUT</b>						
	1	M7	42	6,5	3,5	2701518
	1	M7	42	8,2	3,5	2701519
	1	M6	32	6,5	2,2	2701520
	1	M10x1	44	11	2,4	2701522

	PACKING UNIT	DESCRIPTION/APPLICATION	ORDER CODE
	10	Cylinder bolt with shaft and thread M5 x 19.5, Bolt head Ø 9 mm with Philips H2 fitting, Shaft Ø 6 mm, shaft length 10.2 mm, thread length 6 mm.	2701514



# MAG URA

TRUSTS  
IN SPECIALISTS



# LIQUI MOLY

MAGURA PLACES ITS TRUST IN STRONG PARTNERSHIPS, LIKE WITH LIQUI MOLY. THE LUBRICATION SPECIALISTS FROM ULM ARE THE FIRST CHOICE FOR MAGURA WHEN IT COMES TO PREMIUM OILS AND LUBRICANTS. ASK YOUR MAGURA DEALER WHICH LIQUI MOLY PRODUCTS ARE SUITABLE FOR YOUR MOTORCYCLE.



1



2



3



4



5



6



7



8

POSITION	DESCRIPTION/APPLICATION	ORDER CODE
1	Motorbike Cleaner, 1 l	2100566
2	Motorbike Chain Lube, 200 ml	2100811
	Motorbike Chain Lube, 400 ml	2100567
3	Motorbike Multispray, 50 ml	2100570
4	Motorbike Gloss Spray Wax, 400 ml	2100571
5	Brake Part Cleaner, 500 ml	0103661
6	Thread Lock High Strength, 10 g	2100572
7	Thread Lock Medium Strength, 10 g	2100573
8	Liquid Hand-Wash-Paste, 500 ml	2100574

Learn more about motorcycle brake parts we have.