



national cycle[®]

WORLD'S FINEST MOTORCYCLE WINDSHIELDS AND ACCESSORIES SINCE 1937



Catalog 1

**Windshields and Their Accessories
for American and Metric Motorcycles**

Catalog 2

**VStream® Windscreens for
American and Metric Motorcycles**

Catalog 3

**Quality Riding Accessories for
American and Metric Motorcycles**

Catalog 4

**Wash'n'Wipe™ Windshields for
SxS UTVs and ATV Windshields**

NATIONAL CYCLE: THE WORLD'S FINEST MOTORCYCLE WINDSHIELDS AND ACCESSORIES SINCE 1937

Windshields

National Cycle Innovation	03
SwitchBlade® Quick Release Windshields	04-05
Spartan® Quick Release Windshields	06-07
Wave QR® Quick Release Windshields	08-09
Heavy Duty™ Windshields	10-11
Dakota™ Windshields	12
Street Shield EX™	13
Street Shield™ and Deflector Screen™	14-15
Plexifairing3™ and Plexistar2™	16
F-Series™ Fairings	17
Gladiator® Windshields	18
Mohawk™ Windshields	19
Flyscreen®	20-21
Wave® Windscreens	22
Replacement Screens	23-24
VStream® Windcreens	See Catalog 2: VStream® Windscreens for American and Metric Motorcycles

Windshield Related Items

Shield Wash™ and RainZip®	03
Heat Shields and Wing Deflectors™	25
Hand Deflectors and Chrome Lower Deflectors	26
Holdsters™ and Storage Bags	27

Our Goal

At National Cycle, we think about every product from the rider's perspective. We measure the value of any accessory by how it increases the rider's enjoyment and gives him or her more confidence and ability on the road.

We design for riders and their total riding experience. National Cycle's goal is to craft a refined environment for riders that reinforces them as the center of their world.

Everything we do is about the rider. It's about you.

Good Riding!











Barry Willey
President
National Cycle Inc.





National Cycle Material Icons

-  Quantum® Hardcoated Lexan® Polycarbonate
-  FMR Hardcoated Lexan® Polycarbonate
-  High Impact Acrylic
-  Stainless Steel
-  Steel
-  Machined Aluminum
-  Cast Metal

National Cycle Hardware Icons

-  Fork Mount Quick Release System
-  Fork Mount CH and CJ Series
-  J Series Mount Kits
-  B Series Mount Kits
-  Linking Arm
-  No-Hole Ballsocket™ System
-  Rake Adjust™ Hardware
-  QuickSet™ Windshield Mounts
-  “U” Clamp Mounts
-  QuickSet™ Accessory Mounting System

Other Icons

-  National Cycle 3-Year Warranty
-  ABE Approved German Homologation



Cruiselineer, Dakota, Deflector Screen, DualPivot, F-Series, Heavy Duty, Holdster, Mohawk, No-Hole Ballsocket, Plexifairing, Plexistar, QuickSet, RakeAdjust, Ranger, Street Shield, and Street Shield EX are trademarks of National Cycle, Inc., Maywood, Illinois, U.S.A.

Out In Front is a servicemark of National Cycle, Inc., Maywood, Illinois, U.S.A.

2-Up, Flyscreen, Gladiator, Paladin, Peacemakers, Quantum, RainZip, Spartan, Shorty, SwitchBlade, Quantum, VStream, VStream+, Wave and WaveQR are registered trademarks of National Cycle, Inc., Maywood, Illinois, U.S.A.

Dakota 3.0, Flyscreen, Mohawk, Paladin, Peacemakers, Spartan, SwitchBlade, VStream, Wave, and other National Cycle products are covered by one or more of the following patent numbers: 5732965, 5788313, 5845955, 6234554, 6196614, 6254166, 6484914, 6974175, 7380638, 7387328.

The words BMW, Ducati, Harley-Davidson, Honda, Kawasaki, Suzuki, Triumph and Yamaha are registered trademarks and are the property of their respective trademark holders. All model names and designations for these motorcycles are the property of their respective manufacturers and are used in this catalog for reference purposes only.

First Use of Lexan® Polycarbonate

In 1975, National Cycle was the **first company in the world** to introduce and use GE's Lexan® FMR hard-coated polycarbonate material for motorcycle windshields. Polycarbonate advanced the design and durability of windshields, and the first modern styled, optically clear, custom windshield was created. We called it the **Heavy Duty™**.

The Benefits of Polycarbonate

Outstanding impact strength and crack resistance!

No other thermoplastic comes close to matching the impact strength or crack resistance of polycarbonate, making it the ideal material for motorcycle windshields.

Why Hardcoat Windshields?

Many riders agree that strength is an important benefit but ask, "What affects the optics of a windshield?" Windshields that scratch and craze from debris, the environment, UV exposure and daily wear will contribute to poor optics.

Introducing Quantum® Hardcoating

National Cycle offers a "quantum" improvement in the surface characteristics of windshields exposed to years of wear. We start with a polycarbonate sheet, but it is our **exclusive Quantum® hardcoating** that has defined the new state-of-the-art in windshield scratch resistance and optical clarity.

RainZip® Rain Repellency

In the rain, visibility can be a challenge for the motorcyclist. Rain repellent products that are effective on automotive glass can damage plastic materials. National Cycle's **RainZip®** is a safe and effective hydrophobic repellent you can apply to the surface of your motorcycle windshield. When water hits the surface of the windshield it beads up, and at around 35MPH it simply rolls off.

Windshield Technology Leadership

RainZip was developed in National Cycle's own laboratories specifically for application to their Quantum Hardcoated Windshields, but it's safe and effective on other polycarbonate windshields as well. It's what you've come to expect from the **Worldwide Leader in Windshield Technology**.

Polycarbonate Strength

Polycarbonate vs. Acrylic... YOU Decide!



Watch our online video, "Polycarbonate vs. Acrylic", and see how our hardcoated polycarbonate windshields withstand the kind of abuse that reduces typical acrylic windshields to little pieces!

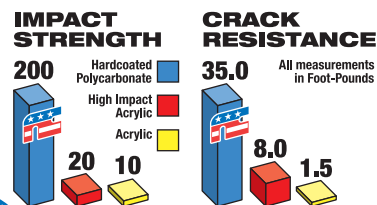

All our Polycarbonate Windshields are made in the USA and are covered by our 3-Year Warranty against breakage.

Quantum Hardcoating



Here we see a motorcycle windshield with typical surface wear and abrasions. This is not what you want in front of you when facing oncoming traffic!

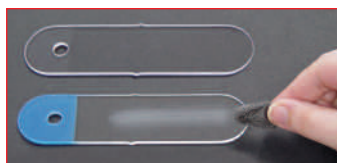

We use a steel wool scratch test to demonstrate the scratch resistance of Quantum hardcoated polycarbonate (top) against acrylic (bottom).

Glare-Free Optics

Think about riding into the sun or at night and not having to look through the glare of fine scratches that eventually shows up on your screens. **Quantum hardcoating gives your windshield much better optical definition and clarity**, and your windshield will stay that way a lot longer.

Superior Scratch Resistance

30X more scratch resistance than typical acrylic windshields is saying a lot! Think of it as 30X more miles per windshield. Even compared to FMR coated polycarbonate, Quantum has **10X** better scratch resistance. That's the kind of performance and strength you need from a motorcycle windshield!

Quantum® is an exclusive product of National Cycle, Inc.

Windshield Care by National Cycle

National Cycle's **N1401-01 Shield Wash™** is mild enough to use often and can be easily carried on your bike.

To keep your windshield clearer in rainy weather, National Cycle developed **N1410-01 RainZip®**, a specially formulated rain repellent treatment for all motorcycle windshields.



Watch our online video and learn how to use National Cycle's Shield Wash™ and RainZip® on your motorcycle windshield and then see a demonstration of how well it works!



VStream® Aeroacoustic Windscreens

National Cycle's innovative VStream® Windscreen gets its name from the unique shape and dimensional contours designed and engineered for each screen. The patented "V" profile helps push the turbulent wind out and away from the side of the rider's head, producing a quieter and more comfortable riding experience for both the rider and the passenger.

VStream+® Windscreens include specially designed and engineered mounting brackets that are a custom fit for each model bike. They're easy to install, require no modifications to existing components, and add strength and rigidity to the windscreen mounting points. VStream+ Mount Brackets are polished, plated or powdercoated to match the finish of each model bike.

VStream®

VStream+®

SwitchBlade® Quick Release 2-Up® Windshield

2-Up®
(Clear)

The largest of the four shields, the **SwitchBlade® 2-Up®** offers maximum protection from the wind and weather for you and your riding partner.

Coupled with a pair of Chrome Lower Deflectors and a National Cycle Light Bar, this windshield can transform your motorcycle into a serious touring bike at a fraction of the price of the upscale machines.

All SwitchBlade windshields features high quality chromed steel and stainless steel hardware. Best of all, their sturdy 4.0mm thick polycarbonate has National Cycle's exclusive Quantum® hardcoating for the ultimate in scratch resistance, as well as a 3-Year Warranty against breakage.

MATERIAL



HARDWARE

Requires Quick Release Mount Kit



Quick Release Versatility!

National Cycle introduced the **world's first quick release windshield hardware** – the original QuickSet™ in 1984 – and we continue to design and develop new features and improvements to ensure you are getting the very best in hassle-free function and long-term quality.

Wind In Your Hair When You Want It... Full Wind Protection When You Need It!™

We know first hand how windshield requirements may change during the season or from ride to ride. It makes good sense to design a hardware system that allows a rider to easily change windshields. Now you can change windshield styles in a matter of seconds, without having to turn one screw!



NOTE:
SwitchBlade 2-Up, Chopped, and Shorty Windshields for Harley-Davidson® Models Feature Key Lock Security!

2-Up®
(Clear)



One Mount Kit... Four Windshields!

The SwitchBlade Quick Release Mounting System gives you the flexibility to mount any one of **four styles** of SwitchBlade Windshields to your motorcycle with **ONE Mount Kit**.

On and Off in Less Than Five Seconds... Without Tools!

This fork-mount hardware system secures your windshield with bulldog tenacity but looks attractive and refined when the shield is off. Innovative stainless steel cushion wheel spools turn and flex, allowing the shield to lock into place with a reassuring "pop".

We design and engineer Quick Release Mount Kits directly on each model motorcycle to ensure perfect fit and function. Mount Kits are available for almost every model bike.



Straight Forks



Tapered Forks



Covered Forks

Quick Release Mount Kits are sold separately.

SwitchBlade® Quick Release Chopped™ Windshield

The **SwitchBlade® Chopped™** is a cut-down version of the popular 2-Up. The recontoured top is 4-5" shorter (depending on model) and the trimmed bottom profile is narrower. Get all the protection you need with the slick looks you want!

Coupled with a pair of Chrome Lower Deflectors and a National Cycle Light Bar, these windshields can transform your motorcycle into a serious touring bike at a fraction of the price of the upscale machines.

Like its 2-Up® big brother, the Chopped is made from tough 4.0mm thick polycarbonate with National Cycle's exclusive Quantum® hardcoating.

MATERIAL



HARDWARE

Requires Quick Release Mount Kit

Chopped™
(Light Tint)



Chopped™
(Clear)



SwitchBlade® Quick Release Shorty® and Deflector™

The smaller screen of the **SwitchBlade® Shorty®** is an ideal choice for a rider who generally does not put long hours in the saddle. Short in size but long on looks and quality features, the Shorty keeps wind blast at bay while preserving the "wind in your face" motorcycling experience.

MATERIAL



HARDWARE

Requires Quick Release Mount Kit

Designed for maximum attitude, the minimal profile of the **SwitchBlade® Deflector™** is a stylish addition to your cruiser. National Cycle's RakeAdjust™ feature allows you to quickly and easily change the screen angle, transforming the SwitchBlade Deflector from a boulevard cruiser to a functional bug buster – or anywhere in between.

MATERIAL



HARDWARE

Requires Quick Release Mount Kit

Shorty®
(Light Tint)



Deflector™
(Clear)



The SwitchBlade Deflector features our Rake Adjust™ so you can easily change your windshield angle.

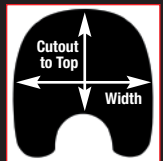

Windshield Measurements

Height is measured from headlight cutout to top of the shield. Width is measured in a straight line across the back of the shield at its widest point.

SwitchBlades are available for a very wide range of bikes, so heights and widths of individual part numbers will vary. See our web site for the specific size of the windshield made for your model bike.

SwitchBlade Windshields are custom sized for each make and model bike.



Clear



Clear 38% Tint



Clear 38% Tint



Clear 38% Tint

How Do SwitchBlade Windshields and Mount Kits Fit Your Bike?

Each SwitchBlade windshield and mount kit is model-specific. These are not "universal" fitments that work fine on some models and work poorly on others. When you order the mount kit and any SwitchBlade windshield for your model bike, you can be sure it will fit like it was custom made for your bike – because it was!

Spartan® Quick Release Windshields

N21302

You won't find a better quality touring-sized windshield at such a great price! The **Spartan® Windshield** has a stainless steel frame finished in a stealthy black powdercoat and looks perfect on today's dark custom bikes.

This full-size Quantum® hardcoated polycarbonate windshield comes in two heights and mounts to our tried-and-true Quick Release Mount Kits, the same kits that mount our SwitchBlade® and Wave QR®.

MATERIAL



HARDWARE



N21200/N21201/N21202/N21203

Cutout to Top: 18.50" (47.0cm)
Width: 18.00" (45.7cm)

Clear

N21300/N21301/N21302/N21303

Cutout to Top: 16.25" (41.3cm)
Width: 18.00" (45.7cm)

Clear

*Height is measured from headlight cutout to top of shield.
Width is measured in a straight line across the back of the shield at its widest point.*



Spartan® Windshields currently fit a wide range of American and metric v-twin cruiser motorcycles.

Check our web site for the latest application and fitment information.



Extend Your Protection!

National Cycle **Chrome Lower Deflectors** attach to our Quick Release Mount Kits and work great with the Spartan Windshields! See page 26 for more information.

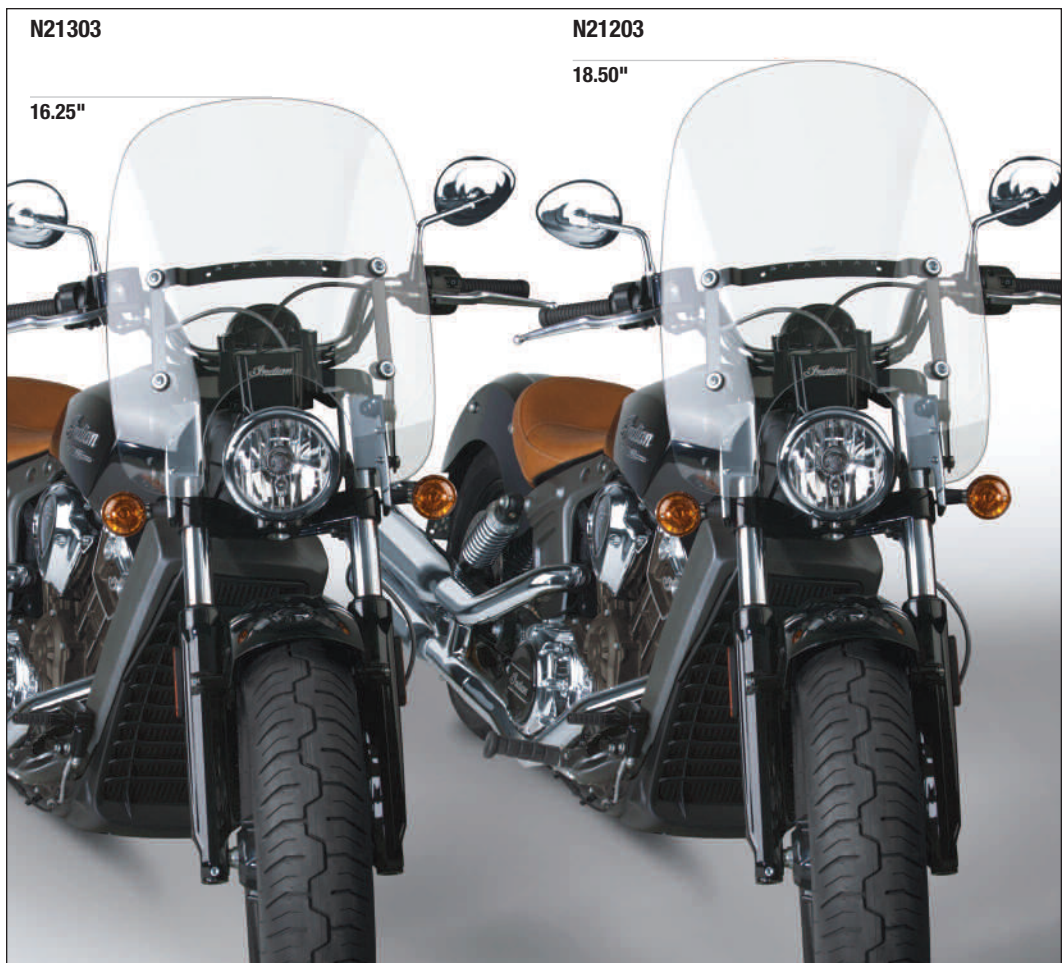

Spartan® Quick Release Windshields

The **Spartan® Windshield** is available in two heights – 18.50" and 16.25" – to fit almost any rider and offer excellent wind protection.

These windshields mount to the forks with our stainless steel Quick Release Mount Kits.

NOTE: Quick Release Mount Kits are model-specific. Check our web site for the correct kit for your make and model.

N21301

Shown with N1321 Holdster™ (see page 27)



Quick Release Mount Kits are sold separately.



Versatile Adjustments!

Simplified fitments are made possible by the Spartan's unique, patented parallel slotted tabs that easily adjust for a perfect, customized fit with different fork widths.

N21300



N21202



On/Off in Less Than Five Seconds!

Spartan Windshields mount to our tried-and-true Quick Release Mount Kits, the same kits that mount our SwitchBlade® Windshields and Wave QR® Fairings.

Spartan Windshields come and off in less than five seconds... without tools!

Wave QR® Quick Release Fairings

N21601

Have the hottest looking bike around with the **Wave QR®** – the fairing that defines performance on the edge. Whether it's slammed back or raked forward, the Wave QR's sculpted body captures the free spirit of your Harley-Davidson® motorcycle.

Its jetstreamed appearance comes from National Cycle's attention to aerodynamics and precision forming... and to making a great looking windshield!

MATERIAL



HARDWARE

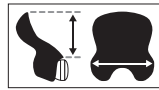

N21601
 Height: 10.50" (26.7cm) **Dark 95% Tint**
 Width: 17.00" (43.2cm)

N21603
 Height: 12.50" (31.8cm) **Dark 95% Tint**
 Width: 18.25" (46.3cm)

Wave QR Fairings are measured from the headlight cutout in a vertical line level to the top of the shield in the fully raked forward position. Width is measured in a straight line across the back of the shield at its widest point.



The **Wave QR® Fairings** are made from FMR hardcoated polycarbonate, the same tough, durable material we introduced to the motorcycle industry in 1975.

Ride it fast and ride it hard – it can take the abuse!

IMPACT STRENGTH **CRACK RESISTANCE**

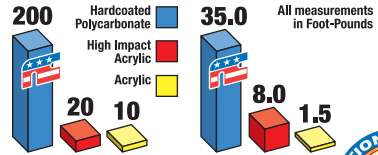

All our Polycarbonate Windshields are made in the USA and are covered by our 3-Year Warranty against breakage.



N21603



Wave QR® Quick Release Fairings

The **Wave QR®** is a quick release fairing... and it's removable in just seconds, without tools, thanks to National Cycle's Quick Release Mount Kit.

And, it's rake adjustable for custom-tuned performance and the looks you want!

MATERIAL



HARDWARE

Requires Quick Release Mount Kit

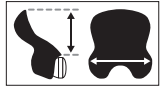

N21604	Height: 10.50" (26.7cm)	Dark 95% Tint
	Width: 18.00" (45.7cm)	
N21605	Height: 10.50" (26.7cm)	Dark 95% Tint
	Width: 18.00" (45.7cm)	
N21610	Height: 13.00" (33.0cm)	Light 25% Tint
	Width: 16.00" (40.6cm)	

Wave QR Fairings are measured from the headlight cutout in a vertical line level to the top of the shield in the fully raked forward position. Width is measured in a straight line across the back of the shield at its widest point.

N21605



Our highly regarded Quick Release Mount Kit is the same kit used for our SwitchBlade® and Spartan® Windshields, so you not only have a choice between riding with or without a shield – you also have a choice between completely different *styles* of quick release shields!

N21610



Quick Release Mount Kits are sold separately.



Quick Release Convenience!

Wave QR Fairings mount to the forks with the same stainless steel quick release hardware that mounts the SwitchBlade® and Spartan® Windshields. Comes on or off in seconds!

Attitude Adjustment!

Wave QR's rake adjustability (range of adjustment varies by model) lets riders adjust the fairing for maximum wind protection or maximum appearance.



Heavy Duty™ Wide Frame Windshields

The classic **Heavy Duty™ Windshields** feature National Cycle's state-of-the-art **Quantum® hardcoating** on Lexan® polycarbonate material. All Heavy Duty windshield frames feature highly polished chrome steel outer hardware with non-glare black epoxy coated steel inner straps.

Available in two frame widths and six sizes, this classic style with an adjustable center window allows fitment to a long legacy of models dating back to the 1949 FL.

The **Touring Heavy Duty™** offers plenty of height and width. Its classic looks will enhance the front end appearance of your bike.

The **Chopped Heavy Duty™** has a wide screen and low profile to make it the preferred choice of many riders. The Chopped provides excellent protection for the chest and shoulders.

MATERIAL    **HARDWARE**    Requires Heavy Duty Mount Kit

Clear Lower

NOTE: The adjustable center window is not Quantum® hardcoated.

N2210 Touring



The **Beaded Heavy Duty™** is an authentic three-piece beaded construction. This timeless classic is available with a clear top and your choice of clear or black lower section and window.

The traditional beaded edge is applied without glue to reduce yellowing and remain good looking for many years. The Beaded Heavy Duty is made from FMR hardcoated Lexan® polycarbonate.

MATERIAL    **HARDWARE**    Requires Heavy Duty Mount Kit

Clear Lower

Black Lower

NOTE: The Beaded Heavy Duty Windshield's inner straps are high gloss polished zinc instead of black epoxy coated.

N2270 Chopped



N2233 Beaded



Heavy Duty Mount Kits are sold separately.



Wide Frame

N2210 Touring	N2270-73 Chopped	N2230-33 Beaded
H: 20.00-21.50" (50.8-54.6cm)	H: 14.25-15.75" (36.2-40.0cm)	H: 19.50-21.25" (49.5-54.0cm)
W: 21.50" (54.6cm)	W: 21.50" (54.6cm)	W: 22.50" (57.0cm)



Optional Beaded Replacement Parts

Pointed Top for Period-Correct Looks
20001 Clear



Early FL-style Notched Lower Window
23010 Clear
23013 Black



FLHS-style Round Lower Window
23030 Clear
23033 Black

Wide Frame or Narrow Frame?

Our bike-specific Heavy Duty™ mounting kits provide the ability to select either a Wide Frame or Narrow Frame Heavy Duty Windshield for your motorcycle to ensure an exact fit and the look you want.

All Heavy Duty mounting kits are bike-specific and sold separately from the windshield.



Height is measured from headlight cutout to top of shield. Width is measured in a straight line across the back of the shield at its widest point.

Heavy Duty Windshields have an adjustable lower window, so the headlight cutout varies depending on individual rider adjustments.

Replacement Screens, Adjustable Windows, and Beaded Separates are available for all Heavy Duty™ Windshields.

Heavy Duty™ Narrow Frame Windshields

The **Narrow Frame Heavy Duty™ Windshields** feature the same quality construction as the Wide Frame Heavy Duty but are designed with a vertical strap spacing of 10.75" for a great fit on both wide or narrow forks.

The **Custom Heavy Duty™** is one of our most popular windshields and offers plenty of height with a slim profile for riders who want long distance touring comfort.

The **Low Boy Heavy Duty™** is the cut down version of the Custom. It is the perfect choice for riders sitting low in the saddle or for the rider who likes a low screen.

The **Ranger Heavy Duty™** cuts the slim profile to its limits for the rider who wants just a small shield. The Ranger looks great on performance-oriented and drag-style cruisers.

MATERIAL



HARDWARE



Requires Heavy Duty Mount Kit

Clear Lower

NOTE: The adjustable center window is not Quantum® hardcoated.

N2220 Custom



Extend Your Protection!

National Cycle **Chrome Lower Deflectors** attach to our Heavy Duty Mount Kits and work great with the Heavy Duty Windshields! See page 26 for more information.

Heavy Duty Mount Kits are sold separately.

N2221 Low Boy



N2290 Ranger



Narrow Frame

N2220 Custom H: 19.00-21.00" (48.2-53.3cm) W: 19.00" (48.3cm)	N2221 Low Boy H: 14.25-16.00" (36.2-40.6cm) W: 18.75" (47.6cm)	N2290 Ranger H: 13.75-16.25" (34.9-41.3cm) W: 16.50" (42.0cm)
---	--	---

All Heavy Duty Mount Kits are designed specifically for each model bike and are sold separately from the windshields. They will mount both our Heavy Duty and our Dakota 4.5 Windshields.



Dakota™ 4.5 Windshields

The Dakota™ 4.5 Windshield is a value-priced alternative to a hardcoated polycarbonate windshield. The Dakota 4.5 is named for its material thickness at 3/16" (4.5mm.) This is a heavy gauge windshield!

Dakota 4.5 uses the same mount kit (see page 11; bottom) as the narrow frame Heavy Duty windshield. For that custom look at a very affordable price, nothing beats the Dakota 4.5.

MATERIAL



HARDWARE



Requires Heavy Duty Mount Kit

Model	Height	Width
 N2301A	18.25" (46.3cm)	24.00" (60.9cm)
N2302A	17.25" (43.8cm)	23.50" (59.7cm)
N2303A	17.25" (43.8cm)	23.50" (59.7cm)
N2304A	18.25" (46.3cm)	23.50" (59.7cm)

Height is measured from headlight cutout to top of screen. Width is measured in a straight line across the back of the screen at its widest point.



Dakota™ 3.0 Windshields

The Dakota™ 3.0 Windshield gives a custom look to many bikes with exposed forks and a fork tube width from 175mm to 245mm (center-to-center).

The Dakota 3.0 is made from High Impact Acrylic and comes complete with all mounting hardware. Get a custom look and great wind protection at a budget price.

MATERIAL



HARDWARE

All mounting hardware included

Model	Height	Width
 NC125A	17.50" (44.5cm)	18.30" (46.5cm)
N2310	20.50" (52.0cm)	18.30" (46.5cm)

Slight Tint

Model	Height	Width
 NC125B	17.50" (44.5cm)	18.30" (46.5cm)
N2320	20.50" (52.0cm)	18.30" (46.5cm)

Slight Tint

Height is measured from headlight cutout to top of screen. Width is measured in a straight line across the back of the screen at its widest point.

N2310

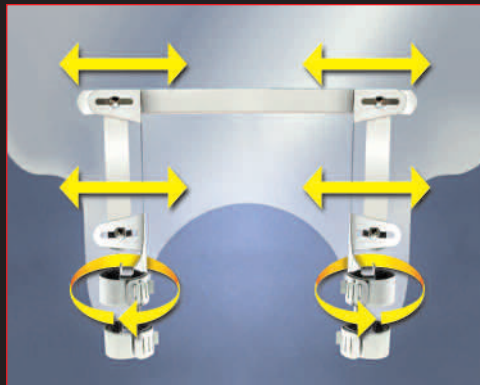

Adaptable Hardware

Patented variable width brackets and adjustable diameter fork clamps allow this windshield to fit almost any make and model motorcycle!

Available in two sizes and two styles for bikes with high or low turn signal placement.

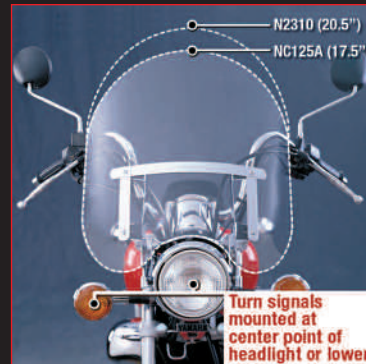

Turn signals mounted at center point of headlight or lower



Turn signals mounted above center point of headlight

Street Shield EX™

The popular **Street Shield EX™** windshield is one of our best sellers. Taller and wider than our Street Shield or Deflector Screen, the EX model provides the rider with excellent upper body protection. This screen is engineered from 3/16" (4.5mm) High Impact Acrylic utilizing our patented No-Hole Ballsocket™ and **QuickSet™** hardware for strength and adjustability. Secured with solid 4-point mounting, the Street Shield EX offers plenty of rider protection.

- N2567** Light Tint; 7/8" (22mm) Handlebar Mount
- N2568** Light Tint; 1" (25mm) Handlebar Mount

MATERIAL **HARDWARE**
  All mounting hardware included



Height: 18.50" (46.9cm)
Width: 19.50" (49.5cm)

Light
25% Tint

Height is measured from headlight cutout to top of screen. Width is measured in a straight line across the back of the screen at its widest point.

N2567

N2567



QuickSet™ Versatility!

The QuickSet™ 4-point mount hardware provides a solid and secure installation for the Street Shield EX Windshield.

Simply turn four knobs and the windshield is off in seconds, while the unobtrusive mounts stay attached to the handlebars and upper fork tubes.

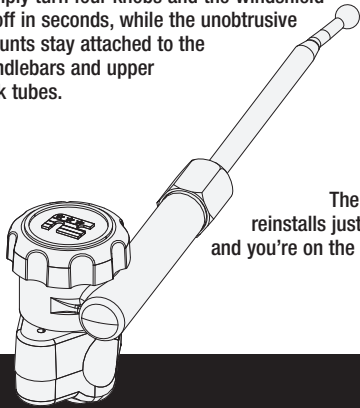

The windshield reinstalls just as quickly, and you're on the road again!

N2568



The Street Shield EX features patented QuickSet™ hardware for quick and easy no-tool installation, adjustment and removal.

Street Shield™ QuickSet™ Windshield

N25012

NEW!

The **Street Shield™ QuickSet™** is a compact windshield, but with enough height and width to offer excellent wind protection.

Four mount points give this windshield excellent rigidity and stability, but simply turning four QuickSet knobs lets you remove (and reinstall) the windshield in seconds.

Best of all, it's made from sturdy polycarbonate with our exclusive Quantum® hardcoating for an unbeatable combination of strength and scratch resistance.

MATERIAL



HARDWARE



All mounting hardware included



Height: 17.00" (43.2cm)
Width: 16.50" (42.0cm)

Clear

Medium
50% Tint

Height is measured from headlight cutout to top of screen. Width is measured in a straight line across the back of the screen at its widest point.



Street Shield™ U-Clamp Windshield

N25000

NEW!

The **Street Shield™ U-Clamp** is the same as the above windshield, but, mounts to the handlebars with easy-to-use U-Clamps. The two lower fork mounts remain the same.

If you don't need to remove your windshield at a moment's notice, this is the one for you. You still get all the benefits of Quantum hardcoated polycarbonate along with world-class quality and looks.

MATERIAL



HARDWARE



All mounting hardware included



Height: 17.00" (43.2cm)
Width: 16.50" (42.0cm)

Clear

Medium
50% Tint

Height is measured from headlight cutout to top of screen. Width is measured in a straight line across the back of the screen at its widest point.



Quantum® is an exclusive product of National Cycle, Inc.

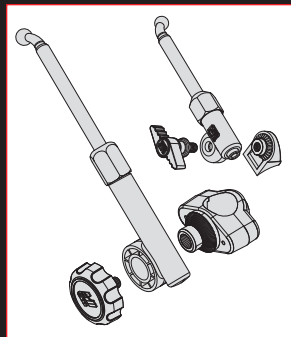

QuickSet™ for Street Shield™

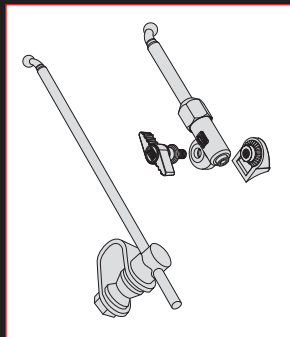

U-Clamp for Street Shield™

Street Shield Models

Part No.	Description	Included Mounting Hardware
N25000	Street Shield; Clear	7/8" (22mm) and 1.00" (25mm) U-Clamp Mounts
N25001	Street Shield; Tint	7/8" (22mm) and 1.00" (25mm) U-Clamp Mounts
		<i>NOTE: BAG#047A and BAG#062 needed for non-tubular bars; BAG#054 and BAG#062 needed for mirror mount.</i>
N25010	Street Shield; Clear	7/8" (22mm) QuickSet Mounts
N25011	Street Shield; Tint	7/8" (22mm) QuickSet Mounts
N25012	Street Shield; Clear	1.00" (25mm) QuickSet Mounts
N25013	Street Shield; Tint	1.00" (25mm) QuickSet Mounts
N25014	Street Shield; Clear	1.25" (31.75) QuickSet Mounts
N25015	Street Shield; Tint	1.25" (31.75) QuickSet Mounts
		<i>NOTE: BAG#047A and BAG#053 needed for non-tubular bars; BAG#053 and BAG#054 needed for mirror mount.</i>

Deflector Screen™ QuickSet™ Windshield

N25040

NEW!

The **Deflector Screen™ QuickSet™**, like our original Deflector Screen DX, is one of the most recognizable and most copied windshields in the world.

Though it's difficult to improve on something that's practically perfect, we did it anyway!

The Deflector Screen is now made from Quantum® hard-coated polycarbonate for unbeatable scratch resistance and impact strength.

Two simple QuickSet™ handlebar mounts lets you take this windshield off or put it back on in just a few seconds – without tools! Plus, its handy RakeAdjust™ lets you set the windshield at the perfect angle for your riding style.

MATERIAL



HARDWARE



All mounting hardware included



Height: 15.50" (39.3cm)
Width: 15.00" (38.1cm)

Clear

Medium
50% Tint

Height is measured from headlight cutout to top of screen. Width is measured in a straight line across the back of the screen at its widest point.



Deflector Screen™ U-Clamp Windshield

N25031

NEW!

The **Deflector Screen™ U-Clamp** is the same as the above windshield, but, mounts to the handlebars with two easy-to-use U-Clamps while retaining the useful RakeAdjust™ feature.

You still get all the benefits of Quantum hardcoated polycarbonate along with world-class quality and the Deflector Screen's famous looks.

This is a windshield that is solidly built to go the extra mile with you.

MATERIAL



HARDWARE



All mounting hardware included



Height: 15.50" (39.3cm)
Width: 15.00" (38.1cm)

Clear

Medium
50% Tint

Height is measured from headlight cutout to top of screen. Width is measured in a straight line across the back of the screen at its widest point.



Quantum® is an exclusive product of National Cycle, Inc.

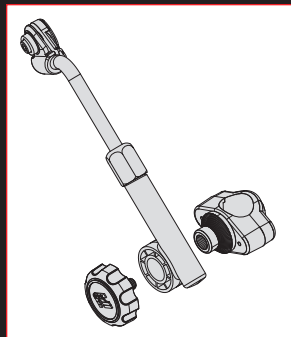

QuickSet™ for Deflector Screen™

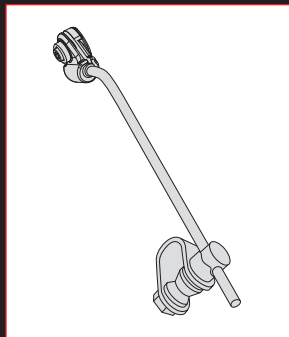

U-Clamp for Deflector Screen™

Deflector Screen Models

Part No.	Description	Included Mounting Hardware
N25030	Deflector Screen; Clear	7/8" (22mm) and 1.00" (25mm) U-Clamp Mounts
N25031	Deflector Screen; Tint	7/8" (22mm) and 1.00" (25mm) U-Clamp Mounts
		<i>NOTE: BAG#047A and BAG#062 needed for non-tubular bars; BAG#054 and BAG#062 needed for mirror mount.</i>
N25040	Deflector Screen; Clear	7/8" (22mm) QuickSet Mounts
N25041	Deflector Screen; Tint	7/8" (22mm) QuickSet Mounts
N25042	Deflector Screen; Clear	1.00" (25mm) QuickSet Mounts
N25043	Deflector Screen; Tint	1.00" (25mm) QuickSet Mounts
N25044	Deflector Screen; Clear	1.25" (31.75) QuickSet Mounts
N25045	Deflector Screen; Tint	1.25" (31.75) QuickSet Mounts
		<i>NOTE: BAG#047A and BAG#053 needed for non-tubular bars; BAG#053 and BAG#054 needed for mirror mount.</i>

Plexifairing 3™, Plexifairing GT™, and Plexistar 2™

We introduced the **Plexifairing 3™** in 1984, and it was an instant hit with riders worldwide. This windshield has truly gone "platinum." And we sell as many today as we did over Three decades ago, proving that superb wind protection, rugged construction and quality materials are things that never go out of style.

The Plexifairing 3 features extended hand and leg protection to make riding more comfortable. A protective gasket is closely fit around the headlight opening.

The Plexifairing 3 also features QuickSet™ hardware, designed for riders who enjoy the advantages of wind protection, but appreciate the luxury of leaving the fairing home when desired.

Designed for specific models to assure a superior fit. Available for most motorcycles.

MATERIAL



HARDWARE



All mounting hardware included. Some motorcycles may require supplemental hardware.



Height and width vary depending on application. Check our web site for information for your make and model bike.

Clear

Plexifairing 3



Plexifairing 3



Plexifairing GT

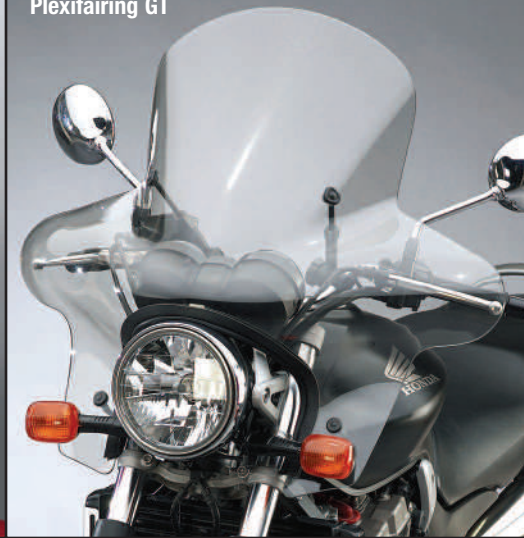

Plexistar 2

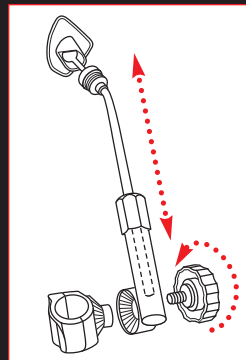

The **PlexifairingGT**, **Plexifairing 3** and **Plexistar 2** feature **National Cycle's patented QuickSet™ hardware**: quick and easy no-tool installation, adjustment and removal.

The **Plexifairing GT™** adds sporting performance to National Cycle's legendary Plexifairing and Plexistar fairings. Like its predecessors, the Plexifairing GT offers outstanding style, great value, and easy installation. There is also full protection for the rider's head, hands, and torso. Available for standard/naked bikes.

MATERIAL



HARDWARE



All mounting hardware included. Some motorcycles may require supplemental hardware.



Slight Tint

Height and width vary depending on application. Check our web site for information for your make and model bike.

MATERIAL



HARDWARE



All mounting hardware included. Some motorcycles may require supplemental hardware.



Clear

Height and width vary depending on application. Check our web site for information for your make and model bike.

F-Series™ F-18, F-16 and F-15 Fairings

These sporty **F-Series™ Fairings** are styled for naked bikes and attach directly to the headlight mount point. Three styles and five different heights provide a wide choice of looks and function.

The stylish **F-18**, shown at right, borrows more than just a label from the double engine fighter. The complex, side to side, double bubble form of the F-18 Fairing is like nothing you've ever seen before.

Like our other polycarbonate windshields, the F-18 is covered by our exclusive 3-Year Warranty against breakage!

MATERIAL
 **HARDWARE**
 All mounting hardware included

 Height: 11.00" (27.9cm)
 Width: 14.00" (35.5cm)
Dark 95% Tint

Height is measured from headlight cutout to top of shield. Width is measured in a straight line across the back of the shield at its widest point.

N2528



F-Series™ F-18 Fairing

BAG#459: Supplemental Adapter Plate for Honda CB900F, CB919, or Hornet 900

Patent #6974175

F-Series™ F-16 Fairings



The **F-16**, a bit tamer in styling than it's F-18 counterpart, is offered in two shield heights. It is also made from Lexan FMR, which is 35 times stronger than acrylic plastic. A great material for this design application. Covered by our 3-Year Warranty against breakage!

MATERIAL
 **HARDWARE**
 All mounting hardware included

 Height: 13.25" (33.6cm)
 Width: 10.25" (26.0cm)
Light 25% Tint

Height is measured from headlight cutout to top of shield. Width is measured in a straight line across the back of the shield at its widest point.



 Height: 10.25" (26.0cm)
 Width: 10.25" (26.0cm)
Dark 95% Tint

F-Series™ F-15 Fairings



The **F-15** is the original F-Series Fairing. The larger of the three styles is made from high impact acrylic. The fairing mounts to the motorcycle's headlight mount point using platinum colored aluminum uprights. The F-15 is the largest of the F-Series Fairings and is offered in two heights.

MATERIAL
 **HARDWARE**
 All mounting hardware included

 Height: 12.00" (34.4cm)
 Width: 21.50" (54.6cm)
Dark 95% Tint

Height is measured from headlight cutout to top of shield. Width is measured in a straight line across the back of the shield at its widest point.



 Height: 17.00" (43.1cm)
 Width: 21.50" (54.6cm)
Light 25% Tint

Gladiator® Height/Rake Adjustable Windshields

N2713

Finally, a custom-looking, small windshield that's worthy of your Harley-Davidson® – the **Gladiator®**!

The clean appearance of its DualPivot™ mounting bracket is achieved by mounting directly to your bike's handlebar top clamp, leaving your handlebars and forks clean and uncluttered.

The Gladiator is made from FMR hardcoated polycarbonate and is available in Light Tint or Dark Tint. Its mounting hardware comes in brilliant chrome or wrinkle finish black to match your bike's OEM finish.

Whether you sit high or low in the saddle, need more or less wind protection, or even if you just want the look that's right... Gladiator Windshields will be the perfect solution!

MATERIAL



HARDWARE

Mounting hardware included



Overall Height: 14.50" (36.8cm)
Width: 12.50" (31.8cm)

Light
25% Tint

Dark
95% Tint

Height is measured from bottom to top of shield. Width is measured in a straight line across the back of the shield at its widest point.



Fits most late-model XL, FXD, FXS and FLS Harley-Davidson® motorcycles.

N2701



N2706



N2709



Adjusts for Height and Rake!

The custom engineered, fully adjustable **DualPivot™** mounting bracket allows a wide range of personalized height and rake positions. There's a perfect setting for any size rider or any weather condition!

A small wrench is all that's needed to change windshield settings. In a complex world, it's satisfyingly simple.



Mohawk™ Windshields

N2831-002

NEW!

Continuing the minimalist, sporty tradition of our famous Flyscreen®, the new **Mohawk™** features a taller and wider size for added wind management. As with our Flyscreen, the versatile Mohawk is adaptable to many motorcycles. Its 4.5mm dark tint FMR hardcoated polycarbonate offers durability and long lasting good looks.

High strength, lightweight, machined aluminum mounting arms have the look of custom billet. The steel fork clamps include rubber gaskets to protect your bike's finish.

Fork clamps are available in three sizes to fit a wide range of fork tube diameters, while the mounting brackets on the windshield itself are adjustable for widths of 8.5"-11.0" (21.6 - 28.0cm) spacing. It's a versatile mounting system that will fit almost any bike with open fork tubes.

National Cycle's Mohawk – The start of a new classic.

MATERIAL



HARDWARE

All mounting hardware included



Height: 09.25" (23.5cm)
Width: 11.75" (29.8cm)

Dark
95% Tint

Height is measured from headlight cutout to top of shield. Width is measured in a straight line across the back of the shield at its widest point.



Mount style may vary depending on motorcycle. Refer to our web site, or call for assistance.

N2831-001



N2831-002



MOHAWK™ PROFILE

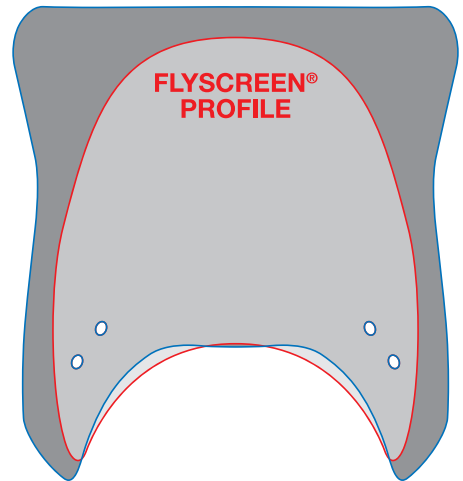

Choose From Chrome or Black Hardware

The patented **Linking Arm** mounting hardware (also used for the Flyscreen®) is custom designed to fit your individual motorcycle.

Your application may require the short straight Linking Arm, the long curved Linking Arm, or – for headlight mount applications – the flat straight Linking Arm.

Whichever mounting hardware fits your make and model, you can choose either a polished chrome or stealth black finish to match the style of your bike.

National Cycle's Black Finish Flyscreen®

N2531-002

NEW!

National Cycle's **Flyscreen®** has been a bestseller for decades, gracing everything from hot v-twin cruisers to naked sport bikes to classic/vintage motorcycles.

Now the standard Flyscreen with chrome faceplates and mounts is joined by its opposite, darker side – a Flyscreen with black faceplates and mounts. They have all the same benefits of the original Flyscreen – superior quality, easy installation, versatile fitments, clean minimalist profile, and reasonable cost – but at an even lower price.

And riders can still choose from Light Tint or Dark Tint for the look they want.

These are perfect windscreens for a less chrome-plated world. Riders... saddle up and come over to the dark side.

LT. TINT MATERIAL



HARDWARE

All mounting hardware included

DK. TINT MATERIAL



Height: 08.50" (21.6cm)
Width: 09.25" (23.5cm)

Light
25% Tint

Dark
95% Tint

Height is measured from headlight cutout to top of shield. Width is measured in a straight line across the back of the shield at its widest point.



Mount style may vary depending on motorcycle. Refer to our web site, or call for assistance.

N2530-002



N2531-002



N2544-002



Flyscreen or Mohawk?

Now that the Flyscreen has been joined by its younger cousin, the Mohawk (both use the exact same **Linking Arm** mounting hardware), riders will be faced with a dilemma – which one to get?

If you lurk on motorcycles forums, you'll see a lot of Flyscreens, especially on Sportsters®, naked bikes and British bikes. You can't go wrong with a timeless classic.

Yet the Mohawk has all the same benefits, but with a little added wind protection and its own unique style and flair.

Like we said, it's a tough choice.

MOHAWK™ PROFILE

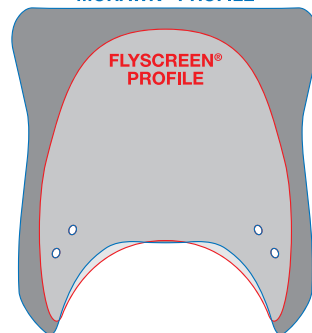

National Cycle's Classic Chrome Flyscreen®

N2530

Add some real sizzle to your performance cruiser! The **Flyscreen®** will give your bike a dragster look – whether you're headed for the quarter-mile strip or the local boulevard.

The clean appearance is accented with a chrome front trim plate. A quality fork-mount system with countersunk screws offers a custom fit for motorcycles with open front ends.

Available in Light Tint or Dark Tint for most American and metric cruiser motorcycles.

And now you can choose from the new Black Finish or the Classic Chrome finish!

LT. TINT MATERIAL



HARDWARE

All mounting hardware included

DK. TINT MATERIAL



Height: 08.50" (21.6cm)
Width: 09.25" (23.5cm)

Light
25% Tint

Dark
95% Tint

Height is measured from headlight cutout to top of shield. Width is measured in a straight line across the back of the shield at its widest point.



Mount style may vary depending on motorcycle. Refer to our web site, or call for assistance.

N2531



N2530



N2544

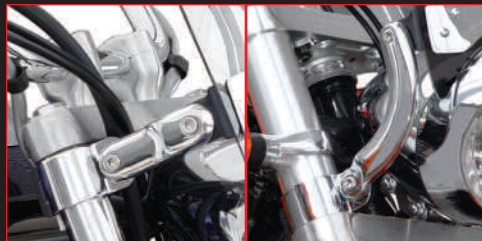

Fork-Mount Flyscreen

The Flyscreen's **Linking Arm** mounting hardware (included) is custom designed to fit your individual motorcycle.

Headlight-Mount Flyscreen

With our headlight-mount models, the Flyscreen can be mounted to almost any standard or sport-standard bike with open forks and exposed headlight bolts. Add a lean, mean look to your machine at a very affordable price.

Flyscreen Headlight-Mount Style is available in Light Tint and Dark Tint for most standard motorcycles.

Wave® Windscreens for FLHT/FLHX/FLTR Models

National Cycle's **Wave® Windscreens** are made for late-model FLHT, FLHX and FLTR motorcycles.

Quality is evident when you feel the thick gauge, precision cut, smooth radiused edge on these windscreens. Quantum® hardcoated polycarbonate delivers outstanding strength and unbeatable scratch resistance.

It's stylish... sleek... and sexy.

It's the Wave. Ride it!

MATERIAL
 
HARDWARE
 Mounts with existing
 OEM hardware

All FLTR Wave Windscreens include metal compression limiters that spread the load for long life and durability.

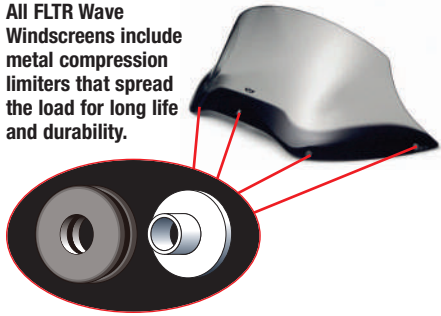

N27403



N27402



N27406



N27404



FLTR Wave Windscreens

10.50" (26.7cm)
 8.25" (21.0cm)
 6.25" (15.9cm)

FLHT/FLHX Wave Windscreens

10.00" (25.4cm)
 7.75" (19.7cm)
 5.25" (13.3cm)

Wave Windscreens are measured from the top of the fairing in a vertical line level to the top of the screen. Three different sizes means there's a perfect Wave Windscreen for any rider.



Harley-Davidson Model

Model Years

Tall Clear

Mid Light Tint

Low Dark Tint

FLHT/FLHTC/FLHTK/FLHTCU Electra Glide	1996-13	N27401	N27402	N27403
FLHX Street Glide	2006-13	N27401	N27402	N27403
FLHTCUTG Tri-Glide Ultra Classic	2009-13	N27401	N27402	N27403
FLHXXX Street Glide Trike	2010-11	N27401	N27402	N27403
FLTR/FLTRU/FLTRX Road Glide/Ultra/Custom	1998-13	N27404	N27405	N27406

Harley-Davidson® FLHR/FLSTC Replacement Screens

Is the shield on your FLHR/FLHRC Road King/Classic or FLSTC Heritage Softail Classic looking old, yellowed and scratched? Then swap it out for a National Cycle Replacement Screen.

Enjoy optical quality, durability and scratch resistance that is superior to OEM and other aftermarket replacement screens. National Cycle's tough 4.0mm thick Quantum® hardcoated polycarbonate screens are computer routed and precision drilled for a guaranteed perfect fit.

National Cycle's Quantum hardcoating is the absolute best windshield material available for motorcycle use!

These screens fit 1994 and later FLHR/FLHRC models, and 2000 and later FLSTC models.

MATERIAL
 **3^{YR}**
HARDWARE
 Mounts with existing OEM hardware

	FLHR/FLHRC	Height	Width
	N31400	20.00" (50.8cm)	21.75" (55.2cm)
	N31401	13.75" (35.0cm)	21.75" (55.2cm)
Clear	FLSTC	Height	Width
Dark 95% Tint	N31405	20.00" (50.8cm)	21.75" (55.2cm)
	N31406	14.38" (36.5cm)	21.75" (55.2cm)

Height is measured from headlight cutout to top of screen. Width is measured in a straight line across the back of the screen at the widest point.

N31401 Shown
(N31406 for FLSTC)

N31400 Shown
(N31405 for FLSTC)



Replacement Screens available for a wide range of years and models. Refer to our web site, or call for assistance.

N2350



Our **Beaded Windshield** for the FXSTS and FXSTSB is trimmed with a traditional beaded edge that is mechanically applied. No yellowing or cracking of glue joints is possible. The highly polished chrome mounts attach to the handlebar risers to provide a significant range of adjustment for height and rake.

MATERIAL
 **3^{YR}**
HARDWARE
 All mounting hardware included

	Height: 13.25" (33.6cm)
	Width: 20.25" (51.4cm)
Clear	

When you're looking for the hard-to-find FLH Replacement Screen for your early model bagger, count on National Cycle for the best quality and the best deal available. Don't be fooled by acrylic imitations. Our FMR hardcoated Lexan® polycarbonate windscreens are CNC routed for a precision fit with a smoothly radiused perimeter edge.

MATERIAL
 **3^{YR}**
HARDWARE
 Mounts with existing OEM hardware

Clear **Light 25% Tint** **Medium 50% Tint**

20052



Harley-Davidson Model	Model Years	Replacement Top; Rounded	Replacement Top; Vintage Pointed
FL Panhead OEM Beaded Shield Top	1949-65	20000	20001
1st Gen. Batwing Fairing	1969~	20000	20001

Harley-Davidson Model	Model Years	Replacement Screen Height	Replacement Screen Color	Part No.
FLHT/FLHTC/FLHTCU	1996-13	12.75"	Clear	20050
FLHT/FLHTC/FLHTCU	1996-13	12.75"	Light Tint	20051
FLHT/FLHTC/FLHTCU	1996-13	08.75"	Medium Tint	20052
FLHT/FLHTC	1986-95	11.75"	Clear	20010
FLHT/FLHTC	1986-95	06.25"	Light Tint	20011
FLH, 4&5 Speed w/ Fairing	1960-85	17.25"	Clear	20030
FLH, 4&5 Speed w/ Fairing	1960-85	07.00"	Light Tint	20041

Replacement Screen for Yamaha® FZ-1

N27306

Optical clarity and precision edge quality make this **Replacement Screen** an unbeatable value for 2001-05 Yamaha® FZ-1 owners. The slightly curved and taller top edge directs wind up and over the rider without causing turbulence.

Made from 4.5mm thick Lexan® polycarbonate with FMR hardcoating for unbeatable crack and impact resistance, as well as excellent abrasion resistance. Best of all, it's covered by National Cycle's 3-Year Warranty against breakage!

MATERIAL



HARDWARE

Mounts with existing OEM hardware



Overall Height: 20.50" (52.1cm)
Width: 15.50" (39.4cm)

Clear

Height is measured from bottom to top of shield. Width is measured in a straight line across the back at the widest point.



Replacement Screen for Honda® ST1100

N27010

This taller-than-stock **Replacement Screen** for the 1990-02 Honda® ST1100 will give riders added wind protection on long tours and in colder weather.

It's 4.5mm thick. FMR hardcoated Lexan® polycarbonate offers outstanding crack and impact resistance, as well as excellent abrasion resistance.

Like all National Cycle polycarbonate windscreens, it's covered by a 3-Year Warranty against breakage!

MATERIAL



HARDWARE

Mounts with existing OEM hardware



Overall Height: 20.00" (50.8cm)
Width: Stock Width

Clear

Height is measured from bottom to top of shield. Width is measured in a straight line across the back at the widest point.



Replacement Screens for Honda® PCX Scooters

National Cycle offers three full-size commuter **Replacement Windscreens** for the Honda® PCX.

Thick, Quantum® hardcoated Lexan® polycarbonate gives excellent optical clarity and strength with 10X more abrasion resistance than acrylic and 23X better crack and impact resistance.

MATERIAL



HARDWARE

Mounts with existing OEM hardware



Model Height Width

2013-2014 Models

N20050 12.75" (32.4cm) 15.50" (39.4cm)
N20051 14.75" (37.4cm) 15.50" (39.4cm)
N20052 16.50" (42.0cm) 15.50" (39.4cm)

2015-Current Models

N50001 12.75" (32.4cm) 15.50" (39.4cm)
N50002 14.75" (37.4cm) 15.50" (39.4cm)
N50003 16.50" (42.0cm) 15.50" (39.4cm)

N20050

N20051

N20052



National Cycle FLH/FLT Heat Shields

N5200

Owners of 2009 and newer Touring models really feel the heat from the rear cylinder. Now you can add protection from the heat or replace the OEM black plastic guards with our **FLH/FLT Heat Shields**.

Our dark tint polycarbonate lets more of the engine show through without letting the heat waves roast your thighs.

Plus, they're a great style complement to our VStream® and our Wave® Windscreens!

MATERIAL
FMR 3^{YR}

HARDWARE
All Mounting
Hardware Included



Wing Deflectors™ for Honda® GL1800

National Cycle's FMR hardcoated polycarbonate **Wing Deflectors™** allow maximum temperature control of air-flow toward or away from the rider. Our unique Swivel Ratchets allow each Deflector to be incrementally adjusted by hand for personalized temperature control.

The one-piece steel brackets are designed for maximum strength and chrome plated for a beautiful finish.

Wing Deflectors come with National Cycle's 3-Year Warranty against breakage!

Fairing Mount Deflectors and Mirror Mount Deflectors come in Light Tint or Dark Tint and fit 2001 and later Honda GL1800 models.

MATERIAL
FMR 3^{YR}

HARDWARE
All Mounting
Hardware Included

**COOL AIR
RELIEF**

**WARM AIR
COMFORT**

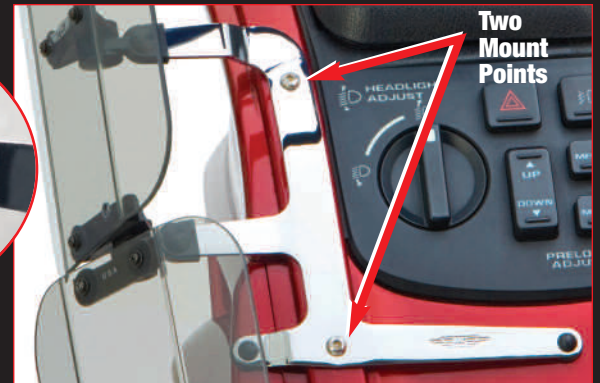

National Cycle Hand Deflectors

National Cycle **Hand Deflectors** are an easy-to-install, economical solution for keeping your hands warm and dry. Coupled with a windshield, Hand Deflectors protect your entire upper body from cold wind and rain.

They extend the riding season when winter gloves are just not enough. They also make heated grips work more effectively.

Hand Deflectors mount easily and securely to your bike's mirror mounts, yet allow plenty of room for lever movement and for riders with large gloves. These hand deflectors make a windshield function more like a fairing.

MATERIAL



HARDWARE

Mount to existing OEM mirror mounts



National Cycle Chrome Lower Deflectors

The best kept secret in motorcycling is **Chrome Lower Deflectors**. They dramatically reduce wind noise, turbulence, and buffeting from below your windshield.

We engineer our Chrome Lower Deflectors for proper clearance and performance, and guarantee their fit with our SwitchBlade®, Spartan®, Heavy Duty™ and Dakota 4.5™ Windshields, as well as our Spotlight Bars.

Superb polishing and chrome plating make National Cycle Chrome Lower Deflectors really stand out.

MATERIAL



HARDWARE



Mounts to National Cycle Quick Release or Heavy Duty Mount Kits

SIZE

Chrome Lower Deflectors are application specific to ensure the correct fit for your motorcycle.



Chrome Lower Deflectors improve the performance of your windshield by preventing unwanted turbulence. Chrome Lower Deflectors can be used together with a SwitchBlade®, Spartan®, Heavy Duty™ or Dakota 4.5™ windshield and a National Cycle Light Bar for an integrated front end appearance.

We engineer our Chrome Lower Deflectors with our other accessories for proper clearance and performance. We consider Chrome Lower Deflectors a key component to your front end look and guarantee the fit of the product with our SwitchBlade, Spartan, Heavy Duty and Dakota 4.5 Windshields, and with our Light Bars.

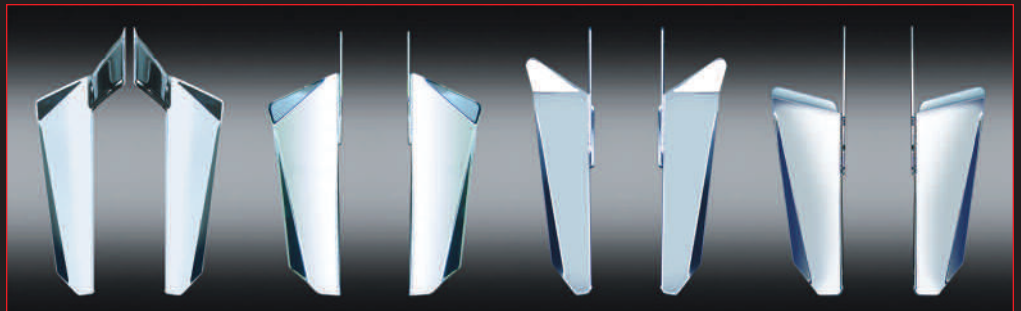

National Cycle Chrome Lower Deflectors are designed on each specific model bike to guarantee perfect fit and function.

Holdster™ Windshield Bags

National Cycle **Holdster™** Windshield Bags offer convenient up-front storage for your gloves, sunglasses, cell phone, garage door opener, tools, etc. Glove-friendly Velcro® closures allow easy one-hand access to your stuff.

Unlike leather tool kits that tend to dry out and become stiff with use, our road-rugged, heavy gauge synthetic leather bags will stand the test of time.

N1310 Triple Holdster

Fits All Wide Frame Heavy Duty™
Main pouch: 11.5" x 5 x 3" (29.2 x 12.7 x 7.6cm)
Side pouches: 4.5" x 4.5" x 3" (11.4 x 11.4 x 7.6cm)

N1320 Single Holdster

Fits All Narrow Frame Heavy Duty™
11.5 x 5 x 3" (29.2 x 12.7 x 7.6cm)

N1321 SwitchBlade Holdster

Fits SwitchBlade® 2-Up/Chopped/Shorty; and Spartan®
12.5 x 5 x 3" (31.8 x 12.7 x 7.6cm)

N1320



N1321



N1310



National Cycle Windshield Storage Bag

National Cycle's **Windshield Storage Bag** will keep your windshield safe and secure when not in use.

The outer bag is 600 denier polyester with a durable, water-proof backing. Industrial-strength zippers, oversized zipper pulls and Tek 70™ industrial thread ensure lasting quality. Inside, your windshield is cradled in a thick, soft pad to provide scratch-free protection for your windshield.

Every rider will appreciate these convenient Windshield Storage Bags!

N1351

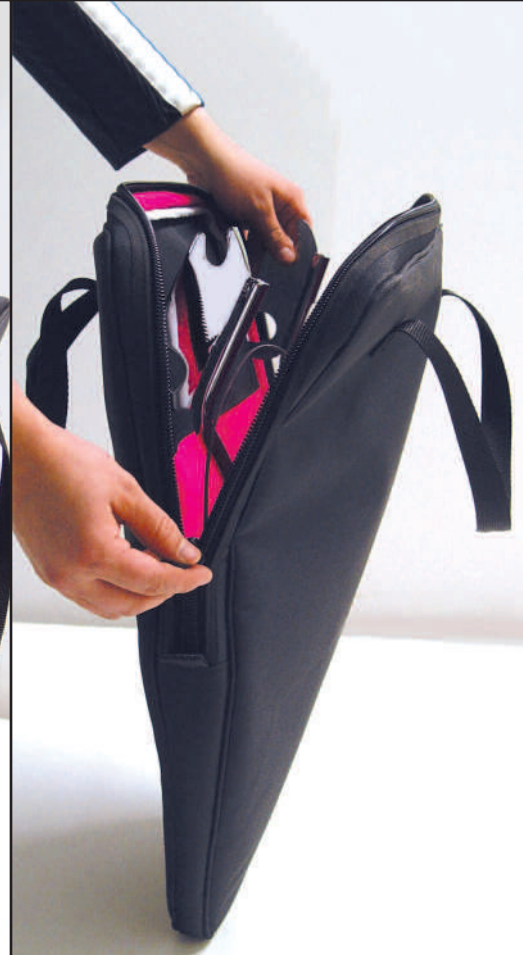

N1351

INNOVATION

INNOVATION... National Cycle's Quantum® Coated Polycarbonate Windshield Technology



First Use of Lexan® Polycarbonate

In 1975, National Cycle was the **first company in the world** to introduce and use GE's Lexan® FMR hardcoated polycarbonate material for motorcycle windshields. Polycarbonate advanced the design and durability of windshields, and the first modern styled, optically clear, custom windshield was created. We called it the **Heavy Duty™**.

What are the Benefits of Polycarbonate?

Outstanding impact strength! No other thermoplastic comes close to matching the impact strength of polycarbonate, making it the ideal material for motorcycle windshields. It is **20X more impact resistant** than acrylic plastic (Lucite®). You can check the data from the Free Falling Steel Dart Test and the IZOD Notch Test but **real world testimonials**, like the one from a customer who met a ball peen hammer at 75MPH attest to the outstanding impact strength of polycarbonate.

Note: National Cycle windshields are designed to provide wind protection and increased riding comfort, but not protection in the event of a collision with another vehicle, an animal, or any other object..

Why Hardcoat Windshields?

Many riders agree that strength is an important benefit, but ask, "**What affects the transparency of a windshield?**" However tough polycarbonate is, it's routinely subjected to surface deterioration from abrasion. Polycarbonate must be hardcoated to be optically clear enough for use as a motorcycle windshield. While most aftermarket companies use acrylic material, some companies use polycarbonate with the FMR hardcoating developed decades ago.

Introducing Quantum®: the New High Standard

Windshields will scratch and craze from debris, the environment, UV and daily wear. National Cycle made a "quantum" improvement in the surface characteristics of windshields exposed to years of wear. We start with a polycarbonate sheet, but it is our **exclusive Quantum® hardcoating** that has **defined the new state-of-the-art standard** in windshield scratch resistance and optical clarity.

Polycarbonate Strength

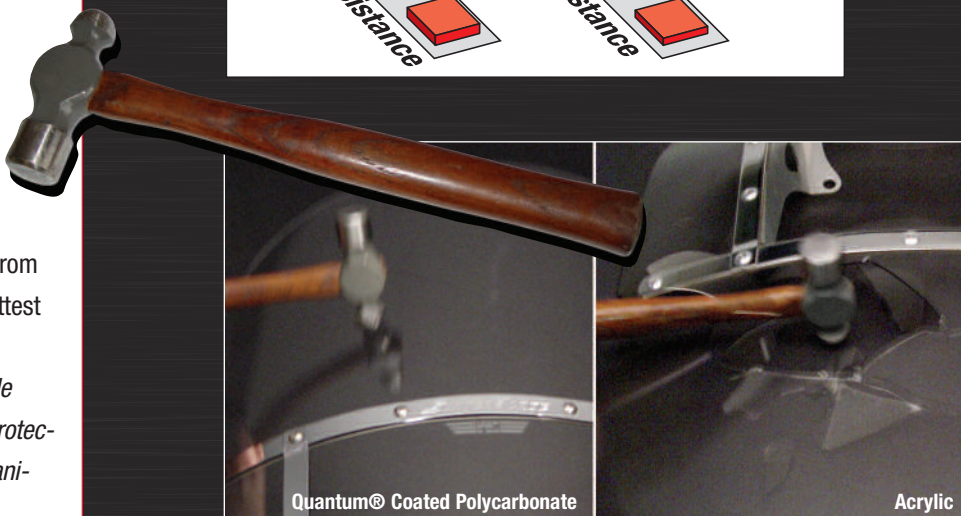
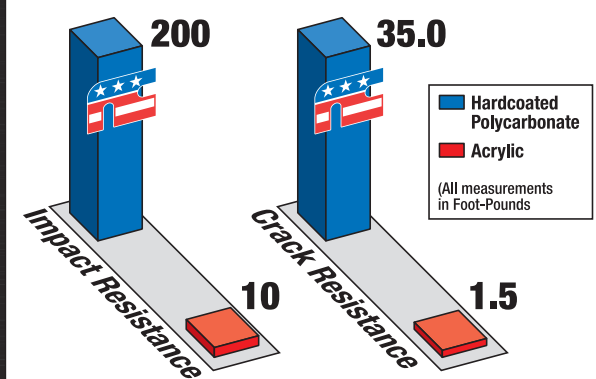

We applied a ball peen hammer at full force to one of our polycarbonate shields (left) and to a competitor's acrylic shield (right). We're professionals – don't try this at home!

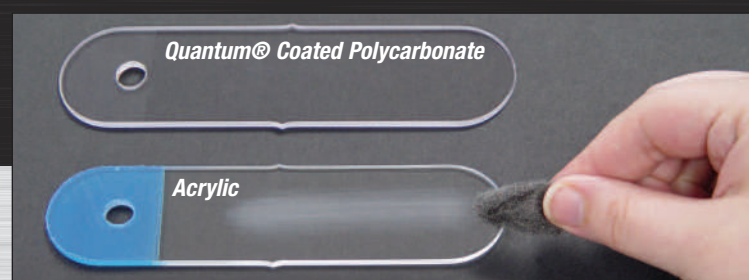

We use a steel wool scratch test to demonstrate the abrasion resistance of Quantum® coated polycarbonate (top) against acrylic (bottom).

Polycarbonate vs. Acrylic... YOU Decide!



Watch our video, "Polycarbonate vs. Acrylic: YOU Decide!", and see how our hardcoated polycarbonate windshields withstand the kind of abuse that reduces typical acrylic windshields to little pieces!

What Makes Quantum Coated Windshields Better Than All the Others?

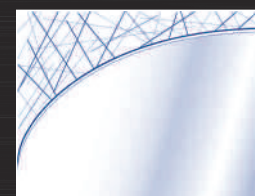

Superior Scratch Resistance

30X more scratch resistance than typical acrylic windshields is saying a lot! Think of it as 30X more miles per windshield. Even compared to FMR coated polycarbonate, Quantum has **10X better scratch resistance**. That's the kind of performance and strength you need from a motorcycle windshield!

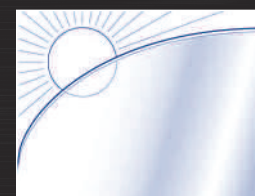

Glare-Free Optics

Think about riding into the sun or at night and not having to look through the glare of fine scratches that eventually show up on your screens. **Quantum coating gives your windshield much better optical definition and clarity**, and your windshield will stay that way a lot longer.



At left is a motorcycle windshield with typical surface wear and abrasions. This is not what you want in front of you when facing oncoming traffic!

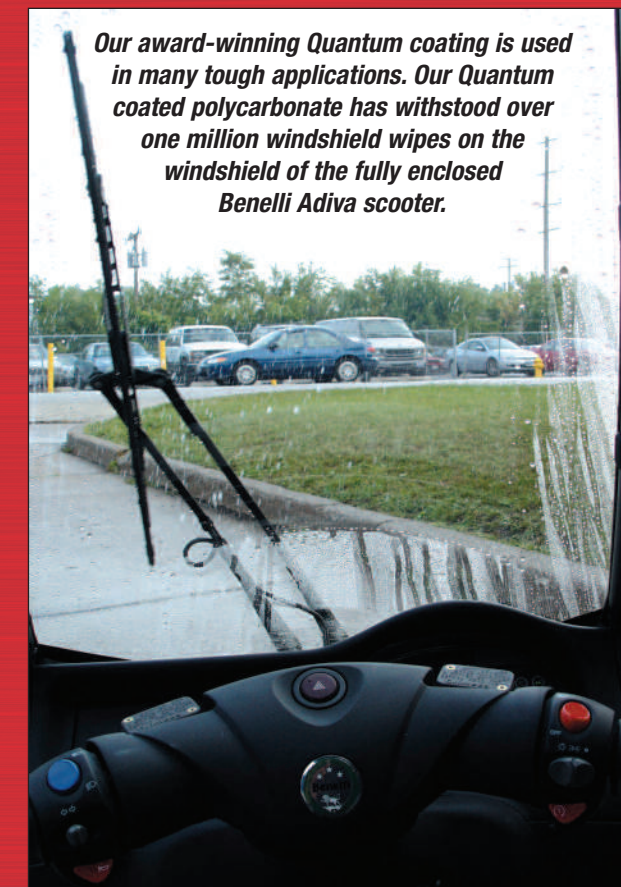

Our award-winning Quantum coating is used in many tough applications. Our Quantum coated polycarbonate has withstood over one million windshield wipes on the windshield of the fully enclosed Benelli Adiva scooter.

Quantum® is an exclusive product of National Cycle, Inc.



Scientific laboratory monitoring and measurement instruments test the surface wear on both hardcoated and uncoated windshield materials.

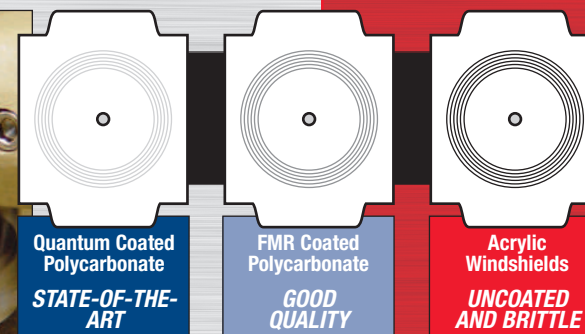



national cycle[®]

WORLD'S FINEST MOTORCYCLE WINDSHIELDS AND ACCESSORIES SINCE 1937

**VStream[®] Aeroacoustic
Windscreens for
Touring
Sport-Touring
Adventure
Naked Bikes**



Catalog 1

Windshields and Their Accessories
for American and Metric Motorcycles

Catalog 2

VStream[®] Windscreens for
American and Metric Motorcycles

Catalog 3

Quality Riding Accessories for
American and Metric Motorcycles

Catalog 4

Wash'n'Wipe[™] Windshields for
SxS UTVs and ATV Windshields

VStream®

National Cycle's innovative VStream® Windscreen gets its name from the unique shape and dimensional contours designed and engineered for each screen. The patented "V" profile helps push the turbulent wind out and away from the side of the rider's head, producing a quieter and more comfortable riding experience for both the rider and the passenger.



VStream+®

VStream+® Windscreens include specially designed and engineered mounting brackets that are a custom fit for each model bike. They're easy to install, require no modifications to existing components, and add strength and rigidity to the windscreen mounting points. VStream+ Mount Brackets are polished, plated or powdercoated to match the finish of each model bike.



Part No.	Model	Years	Coating/Color	Height	Width
DUCATI					
N28213	M696/796/1100	2008-14	FMR; Dk.Tint	15.25" (38.7cm) ³	15.00" (38.1cm)
N28214	M696/796/1100	2008-14	FMR; Clear	18.00" (45.7cm) ³	15.00" (38.1cm)
N28213	M821 Monster	2015-18	FMR; Dk.Tint	15.25" (38.7cm) ³	15.00" (38.1cm)
N28214	M821 Monster	2015-18	FMR; Clear	18.00" (45.7cm) ³	15.00" (38.1cm)
N20500	Multistrada 1200/S	2010-12	FMR; Clear	22.50" (57.1cm) ³	16.00" (40.6cm)
N20501	Multistrada 1200/S	2010-12	FMR; Lt.Tint	19.50" (49.5cm) ³	14.50" (36.8cm)
N20502	Multistrada 1200/S	2010-12	FMR; Dk.Tint	17.50" (44.5cm) ³	13.50" (34.3cm)

HARLEY-DAVIDSON					
N20401	FLHT/FLHX Models	1996-13	Quantum; Clear	17.00" (43.2cm) ²	19.25" (48.9cm)
N20403	FLHT/FLHX Models	1996-13	Quantum; Clear	14.00" (35.5cm) ²	18.75" (47.6cm)
N20404	FLHT/FLHX Models	1996-13	Quantum; Dk.Tint	10.75" (27.3cm) ²	17.63" (44.8cm)
N20405	FLHT/FLHX Models	1996-13	Quantum; Lt.Tint	10.75" (27.3cm) ²	16.00" (40.6cm)
N20406	FLHT/FLHX Models	1996-13	Quantum; Dk.Tint	07.25" (18.4cm) ²	17.63" (44.8cm)
N20407	FLHT/FLHX Models	2014-18	Quantum; Clear	14.50" (39.4cm) ²	Stock Base Width
N20408	FLHT/FLHX Models	2014-18	Quantum; Clear	11.50" (29.2cm) ²	Stock Base Width
N20409	FLHT/FLHX Models	2014-18	Quantum; Lt.Tint	09.50" (24.1cm) ²	Stock Base Width
N20410	FLHT/FLHX Models	2014-18	Quantum; Lt.Tint	07.50" (19.0cm) ²	Stock Base Width
N20411	FLHT/FLHX Models	2014-18	Quantum; Dk.Tint	07.25" (18.4cm) ²	Stock Base Width
N20421	FLTR Models	1998-13	Quantum; Clear	18.00" (45.7cm) ¹	Stock Base Width
N20422	FLTR Models	1998-13	Quantum; Clear	15.25" (38.7cm) ¹	Stock Base Width
N20423	FLTR Models	1998-13	Quantum; Dk.Tint	09.25" (23.5cm) ¹	Stock Base Width
N20424	FLTR Models	1998-13	Quantum; Lt.Tint	09.25" (23.5cm) ¹	Stock Base Width
N20425	FLTR Models	1998-13	Quantum; Clear	12.00" (30.5cm) ¹	Stock Base Width
N20431	FLTR Models	2015-18	Quantum; Clear	16.00" (40.6cm) ¹	Stock Base Width
N20432	FLTR Models	2015-18	Quantum; Lt.Tint	12.50" (31.7cm) ¹	Stock Base Width
N20433	FLTR Models	2015-18	Quantum; Dk.Tint	09.00" (22.8cm) ¹	Stock Base Width

HONDA					
N20045	CB500X	2013-15	FMR; Dk.Tint	15.25" (38.7cm) ³	15.50" (39.3cm)
N20046	CB500X	2013-15	FMR; Lt.Tint	18.00" (45.7cm) ³	15.50" (39.3cm)
N20047	CB500X	2013-15	FMR; Clear	21.00" (53.3cm) ³	15.50" (39.3cm)
N20054	CB500F	2013-18	FMR; Dk.Tint	16.00" (40.6cm) ³	16.00" (40.6cm)
N20055	CB500F	2013-18	FMR; Lt.Tint	19.25" (48.9cm) ³	18.25" (46.3cm)
N20056	CB500F	2013-18	FMR; Clear	21.75" (55.2cm) ³	19.25" (48.9cm)
N20002	NT700V/NT700VA	2008-12	Quantum; Clear	19.30" (49.0cm) ³	21.25" (54.0cm)
N20007	NC700/750X,XA,XD	2013-15	FMR; Dk.Tint	15.00" (38.1cm) ³	13.00" (33.0cm)
N20008	NC700/750X,XA,XD	2013-15	FMR; Lt.Tint	18.50" (47.0cm) ³	14.37" (36.5cm)
N20009	NC700/750X,XA,XD	2013-15	FMR; Clear	22.00" (55.9cm) ³	16.00" (40.6cm)
N20057	CRF1000L Africa Twin	2015-17	FMR; Dk.Tint	17.25" (43.8cm) ³	14.25" (36.2cm)
N20058	CRF1000L Africa Twin	2015-17	FMR; Lt.Tint	20.25" (51.4cm) ³	17.50" (44.4cm)
N20059	CRF1000L Africa Twin	2015-17	FMR; Clear	23.00" (58.4cm) ³	18.75" (47.6cm)
N20005	VFR1200	2010-13	FMR; Lt.Tint	23.58" (59.9cm) ³	15.25" (38.7cm)
N20006	VFR1200	2010-13	FMR; Lt.Tint	25.25" (64.1cm) ³	17.00" (43.2cm)
N20001	ST1300	2003-12	Quantum; Clear	19.00" (48.2cm) ³	23.30" (59.2cm)
N20031**	GL1500 Gold Wing	1988-00	Quantum; Clear	25.75" (65.4cm) ¹	25.50" (64.8cm)
N20032*	GL1500 Gold Wing	1988-00	Quantum; Clear	25.75" (65.4cm) ¹	25.50" (64.8cm)
N20012**	GL1800 Gold Wing	2001-17	Quantum; Clear	22.00" (55.9cm) ¹	26.00" (66.0cm)
N20012A*	GL1800 Gold Wing	2001-17	Quantum; Clear	22.00" (55.9cm) ¹	26.00" (66.0cm)
N20014	GL1800 Gold Wing	2001-17	Quantum; Clear	22.00" (55.9cm) ¹	26.00" (66.0cm)
N20019	GL1800 Gold Wing	2018	Quantum; Clear	TBD	TBD
N20020	GL1800 Gold Wing	2018	Quantum; Clear	TBD	TBD
N20021	GL1800 Gold Wing	2018	Quantum; Clear	TBD	TBD
N20022	GL1800 Gold Wing	2018	Quantum; Clear	TBD	TBD
N20023	GL1800 Gold Wing	2018	Quantum; Clear	TBD	TBD
N20024	GL1800 Gold Wing	2018	Quantum; Clear	TBD	TBD
N20016	GL1800 F6B	2013-16	Quantum; Dk.Tint	09.33" (23.7cm) ¹	25.25" (64.1cm)
N20017	GL1800 F6B	2013-16	Quantum; Lt.Tint	12.80" (32.5cm) ¹	26.00" (66.0cm)
N20018	GL1800 F6B	2013-16	Quantum; Clear	16.33" (41.5cm) ¹	26.25" (66.7cm)

INDIAN					
N20703	Chieftain, Roadmaster	2014-18	Quantum; Dk.Tint	TBD	TBD
N20704	Chieftain, Roadmaster	2014-18	Quantum; Lt.Tint	TBD	TBD
N20705	Chieftain, Roadmaster	2014-18	Quantum; Clear	TBD	TBD

Quantum® Hardcoated Lexan® Polycarbonate
 Developed for windshield use by National Cycle, Quantum hardcoating takes motorcycle windshields a quantum leap forward in scratch resistance and out-door life. The durability of polycarbonate combined with Quantum hardcoating produces the strongest, most scratch resistant windshield available.

FMR Hardcoated Lexan® Polycarbonate
 The strength of polycarbonate combined with FMR hardcoating provides strength with good scratch resistance. FMR polycarbonate is the OEM motorcycle industry standard and was first developed for the motorcycle industry by National Cycle.

National Cycle 3-Year Warranty
 Our exclusive 3-Year Warranty covers all National Cycle polycarbonate windshields and windshields against breakage.

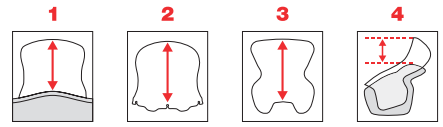

- Centerline measurement from top of screen to top of fairing edge
- Centerline measurement from top of screen to bottom center mount hole
- Centerline measurement from top of screen to bottom edge
- Measured from top of stock headlight shroud to top of screen

* With vent hole; use OEM vent/hardware for direct replacement, or use National Cycle's 23050 Replacement Vent
 ** Without vent hole

All widths are measured in a straight horizontal line across the back of the screens at their widest point.

VStream Applications and Specifications

VStream+ with Mount Kit

N20121 N20122 N20123



N20112 N20113 N20114



N20118 N20119 N20120



N20124 N20125 N20126



N20800 N20801 N20802



N20804 N20805 N20806



N20217A N20218A N20219A



NEW Product

Part No.	Model	Years	Coating/Color	Height	Width
KAWASAKI					
N20108	EX300 Ninja	2013-17	FMR; Dk.Tint	17.13" (43.5cm) ³	14.00" (35.5cm)
N20111	EX300 Ninja	2013-17	FMR; Lt.Tint	17.13" (43.5cm) ³	14.00" (35.5cm)
N20109	EX300 Ninja	2013-17	FMR; Lt.Tint	20.50" (52.1cm) ³	16.00" (40.6cm)
N20110	EX300 Ninja	2013-17	FMR; Clear	24.25" (61.6cm) ³	18.00" (45.7cm)
N20124	KLE300 Versys-X	2017-18	Quantum; Dk.Tint	13.63" (34.6cm) ³	13.25" (33.6cm)
N20125	KLE300 Versys-X	2017-18	Quantum; Lt.Tint	16.00" (40.6cm) ³	14.00" (35.5cm)
N20126	KLE300 Versys-X	2017-18	Quantum; Clear	18.63" (47.3cm) ³	14.75" (37.4cm)
N20112	KLR650	2008-18	FMR; Dk.Tint	15.75" (40.0cm) ¹	12.00" (30.5cm)
N20113	KLR650	2008-18	FMR; Lt.Tint	18.00" (45.7cm) ¹	14.50" (36.8cm)
N20114	KLR650	2008-18	FMR; Clear	20.75" (52.7cm) ¹	16.00" (40.6cm)
N20100	KLE650 Versys	2008-09	FMR; Clear	14.75" (37.4cm) ³	15.00" (38.1cm)
N20115	KLE650/1000 Versys	2015-16	FMR; Dk.Tint	13.25" (33.6cm) ³	13.38" (33.9cm)
N20116	KLE650/1000 Versys	2015-16	FMR; Lt.Tint	15.75" (40.0cm) ³	14.25" (36.2cm)
N20117	KLE650/1000 Versys	2015-16	FMR; Clear	18.25" (46.3cm) ³	15.00" (38.1cm)
N20118	KLE650/1000 Versys	2017-18	FMR; Dk.Tint	13.25" (33.6cm) ³	13.38" (33.9cm)
N20119	KLE650/1000 Versys	2017-18	FMR; Lt.Tint	15.75" (40.0cm) ³	14.25" (36.2cm)
N20120	KLE650/1000 Versys	2017-18	FMR; Clear	18.25" (46.3cm) ³	15.00" (38.1cm)
N20105	Z1000SX Ninja	2011-16	FMR; Dk.Tint	19.50" (49.5cm) ³	16.00" (40.6cm)
N20106	Z1000SX Ninja	2011-16	FMR; Lt.Tint	19.50" (49.5cm) ³	16.00" (40.6cm)
N20107	Z1000SX Ninja	2011-16	FMR; Clear	22.38" (56.8cm) ³	17.00" (43.2cm)
N20121	Z1000SX Ninja	2017-18	Quantum; Dk.Tint	15.38" (39.0cm) ³	12.63" (32.0cm)
N20122	Z1000SX Ninja	2017-18	Quantum; Lt.Tint	18.00" (45.7cm) ³	12.75" (32.4cm)
N20123	Z1000SX Ninja	2017-18	Quantum; Clear	22.50" (57.1cm) ³	14.50" (39.4cm)
N20102	ZG1400A Concours	2008-14	Quantum; Clear	24.10" (61.3cm) ³	21.00" (53.3cm)

KTM

N20800	1050/90/1190 Adv./Adv.R	2014-18	FMR; Dk.Tint	13.75" (35.0cm) ³	14.75" (37.4cm)
N20801	1050/90/1190 Adv./Adv.R	2014-18	FMR; Lt.Tint	16.25" (41.3cm) ³	16.00" (40.6cm)
N20802	1050/90/1190 Adv./Adv.R	2014-18	FMR; Clear	18.50" (47.0cm) ³	16.75" (42.5cm)
N20803	1050/90/1190 Adv./Adv.R	2014-18	FMR; Lt.Tint	13.75" (35.0cm) ³	14.75" (37.4cm)
N20804	1290 Super Duke GT	2017-18	FMR; Dk.Tint	12.88" (32.7cm) ³	12.63" (32.0cm)
N20805	1290 Super Duke GT	2017-18	FMR; Lt.Tint	12.88" (32.7cm) ³	12.63" (32.0cm)
N20806	1290 Super Duke GT	2017-18	FMR; Clear	17.00" (43.2cm) ³	14.75" (37.4cm)
N20807	1290 Super Adv./T	2015-18	Quantum; Dk.Tint	13.75" (35.0cm) ³	14.75" (37.4cm)
N20808	1290 Super Adv./T	2015-18	Quantum; Lt.Tint	16.25" (41.3cm) ³	16.00" (40.6cm)
N20809	1290 Super Adv./T	2015-18	Quantum; Clear	18.50" (47.0cm) ³	16.75" (42.5cm)

SUZUKI

N20214	DL650 V-Strom	2012-16	FMR; Dk.Tint	18.90" (48.0cm) ³	17.70" (45.0cm)
N20215	DL650 V-Strom	2012-16	FMR; Lt.Tint	22.30" (56.6cm) ³	17.70" (45.0cm)
N20216	DL650 V-Strom	2012-16	FMR; Clear	25.80" (65.5cm) ³	17.70" (45.0cm)
N20220	DL650 V-Strom	2017-18	FMR; Dk.Tint	14.00" (35.5cm) ³	14.25" (36.2cm)
N20221	DL650 V-Strom	2017-18	FMR; Lt.Tint	16.50" (41.9cm) ³	16.38" (41.6cm)
N20222	DL650 V-Strom	2017-18	FMR; Clear	19.00" (48.2cm) ³	17.38" (44.1cm)
N28216	M50 Boulevard/M800	2010-18	FMR; Dk.Tint	19.50" (49.5cm) ³	16.60" (42.2cm)
N28217	M50 Boulevard/M800	2010-18	FMR; Lt.Tint	22.20" (56.4cm) ³	17.10" (43.4cm)
N20213	DL650/1000 V-Strom	2004-12	FMR; Clear	20.75" (52.7cm) ³	17.13" (43.5cm)
N20217A	DL1000 V-Strom	2014-18	FMR; Dk.Tint	14.00" (35.5cm) ³	13.75" (34.9cm)
N20218A	DL1000 V-Strom	2014-18	FMR; Lt.Tint	16.50" (41.9cm) ³	16.00" (40.6cm)
N20219A	DL1000 V-Strom	2014-18	FMR; Clear	18.75" (47.6cm) ³	18.50" (47.0cm)
N20200	GSF1250 Bandit	2007-16	Quantum; Clear	22.00" (55.9cm) ³	16.50" (42.0cm)
N20201	GSF1250 Bandit	2007-16	Quantum; Lt.Tint	19.00" (48.3cm) ³	15.50" (39.4cm)
N28208	M90 Boulevard/M1500	2009-18	FMR; Dk.Tint	19.50" (49.5cm) ³	16.60" (42.2cm)
N28209	M90 Boulevard/M1500	2009-18	FMR; Dk.Tint	22.20" (56.4cm) ³	17.10" (43.4cm)
N28210	M90 Boulevard/M1500	2009-18	FMR; Lt.Tint	22.20" (56.4cm) ³	17.10" (43.4cm)
N28201	M109R Boulevard	2006-18	FMR; Dk.Tint	07.00" (17.8cm) ⁴	16.50" (41.9cm)
N28202	M109R Boulevard	2006-18	FMR; Dk.Tint	10.00" (25.4cm) ⁴	17.00" (43.2cm)
N28203	M109R Boulevard	2006-18	FMR; Lt.Tint	10.00" (25.4cm) ⁴	17.00" (43.2cm)
N28204	M109R2 Boulevard	2008-10	FMR; Dk.Tint	16.00" (40.6cm) ³	16.25" (41.3cm)

N20220 N20221 N20222



VStream Applications and Specifications

NEW Product

VStream+ with Mount Kit

N20600 N20601 N20602



N20603 N20604 N20605



N20700 N20701 N20702



N20322 N20323 N20324



N20316 N20317 N20318



Part No.	Model	Years	Coating/Color	Height	Width
TRIUMPH					
N20600	Tiger 800/800XC	2011-17	FMR; Dk.Tint	14.00" (35.5cm) ³	19.00" (48.3cm)
N20601	Tiger 800/800XC	2011-17	FMR; Lt.Tint	18.00" (45.7cm) ³	19.00" (48.3cm)
N20602	Tiger 800/800XC	2011-17	FMR; Clear	21.00" (53.3cm) ³	19.00" (48.3cm)
N20603	Tiger Explorer 1200	2010-15	FMR; Dk.Tint	16.70" (42.4cm) ³	18.60" (47.2cm)
N20604	Tiger Explorer 1200	2010-15	FMR; Lt.Tint	20.40" (51.8cm) ³	18.60" (47.2cm)
N20605	Tiger Explorer 1200	2010-15	FMR; Clear	24.00" (61.0cm) ³	19.60" (49.8cm)
N20606	Trophy/SE 1200	2013-17	FMR; Lt.Tint	17.63" (44.7cm) ³	23.25" (59.0cm)
N20607	Trophy/SE 1200	2013-17	FMR; Clear	21.00" (53.3cm) ³	24.75" (62.8cm)
N20608	Trophy/SE 1200	2013-17	FMR; Clear	24.00" (61.0cm) ³	24.75" (62.8cm)

VICTORY

N20700	Cross Country	2010-17	FMR; Clear	12.25" (31.1cm) ¹	25.75" (64.4cm)
N20701	Cross Country	2010-17	FMR; Lt.Tint	10.25" (26.0cm) ¹	25.75" (64.4cm)
N20702	Cross Country	2010-17	FMR; Dk.Tint	08.25" (21.0cm) ¹	25.75" (64.4cm)

YAMAHA

N20313	FZ-07	2014-16	FMR; Dk.Tint	12.00" (30.5cm) ³	14.38" (36.5cm)
N20314	FZ-07	2014-16	FMR; Lt.Tint	15.00" (38.1cm) ³	15.38" (39.0cm)
N20315	FZ-07	2014-16	FMR; Clear	18.00" (45.7cm) ³	17.63" (44.7cm)
N20310	FZ-09	2014-16	FMR; Dk.Tint	09.00" (22.9cm) ³	15.50" (39.4cm)
N20311	FZ-09	2014-16	FMR; Lt.Tint	12.50" (32.5cm) ³	15.50" (39.4cm)
N20312	FZ-09	2014-16	FMR; Clear	16.75" (42.5cm) ³	17.50" (44.4cm)
N20322	FZ-09/MT-09	2017-18	Quantum; Dk.Tint	15.25" (38.7cm) ³	14.75" (37.5cm)
N20323	FZ-09/MT-09	2017-18	Quantum; Lt.Tint	18.38" (46.7cm) ³	15.50" (39.4cm)
N20324	FZ-09/MT-09	2017-18	Quantum; Clear	21.38" (54.3cm) ³	16.75" (42.5cm)
N20316	FJ-09/MT-09 Tracer	2014-17	FMR; Dk.Tint	17.63" (44.7cm) ³	12.75" (32.4cm)
N20317	FJ-09/MT-09 Tracer	2014-17	FMR; Lt.Tint	20.50" (52.0cm) ³	16.00" (40.6cm)
N20318	FJ-09/MT-09 Tracer	2014-17	FMR; Clear	23.63" (60.0cm) ³	17.50" (44.4cm)
N20325	FZ-10/MT-10	2017-18	Quantum; Dk.Tint	TBD	TBD
N20326	FZ-10/MT-10	2017-18	Quantum; Lt.Tint	TBD	TBD
N20327	FZ-10/MT-10	2017-18	Quantum; Clear	TBD	TBD
N20303	FZ-1	2006-13	FMR; Clear	20.50" (52.0cm) ³	16.50" (41.9cm)
N20304	XT1200 Super Ténéré	2012-13	FMR; Dk.Tint	18.50" (47.0cm) ³	15.75" (40.0cm)
N20305	XT1200 Super Ténéré	2012-13	FMR; Lt.Tint	21.25" (54.0cm) ³	16.00" (40.6cm)
N20306	XT1200 Super Ténéré	2012-13	FMR; Clear	24.25" (61.5cm) ³	17.00" (43.2cm)
N20319	XT1200 Super Ténéré	2014-18	FMR; Dk.Tint	19.00" (48.3cm) ³	14.75" (37.5cm)
N20320	XT1200 Super Ténéré	2014-18	FMR; Lt.Tint	21.75" (55.3cm) ³	15.75" (40.0cm)
N20321	XT1200 Super Ténéré	2014-18	FMR; Clear	24.00" (60.9cm) ³	16.75" (42.5cm)
N20301	FJR1300	2001-05	Quantum; Clear	20.50" (52.0cm) ³	21.50" (54.6cm)
N20302	FJR1300	2006-12	Quantum; Clear	20.50" (52.0cm) ³	21.50" (54.6cm)
N20307	FJR1300	2013-18	FMR; Dk.Tint	17.25" (43.8cm) ³	20.50" (52.0cm)
N20308	FJR1300	2013-18	FMR; Lt.Tint	20.25" (51.4cm) ³	20.50" (52.0cm)
N20309	FJR1300	2013-18	FMR; Clear	23.25" (59.0cm) ³	20.50" (52.0cm)

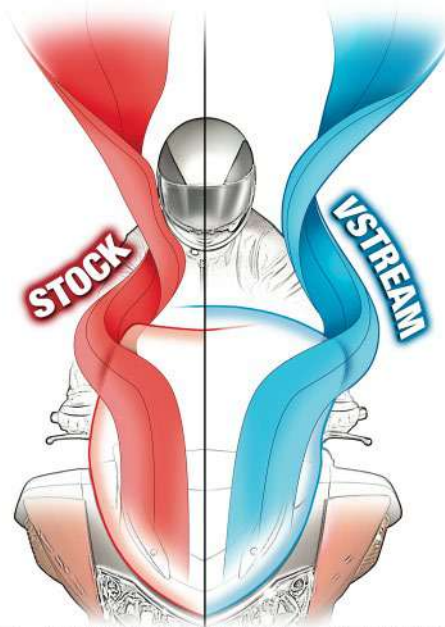

QUIET • COMFORT • OPTICS • STRENGTH

**EXPERIENCE THE
VSTREAM DIFFERENCE!**

VStream[®]

National Cycle's innovative VStream[®] Windscreen gets its name from the unique shape and dimensional contours designed and engineered for each screen. The patented "V" profile helps push the turbulent wind out and away from the side of the rider's head, producing a quieter and more comfortable riding experience for both the rider and the passenger.

VStream Fairing-Mount Windscreen Applications

Part No.	Coating/Screen Color	Height
HARLEY-DAVIDSON		
FLHT/FLHTC/FLHTK/FLHTCU Electra Glide 1996-13; FLHTCUTG Tri-Glide Ultra Classic 2009-13; FLHX Street Glide 2006-13; FLHXXX Street Glide Trike 2010-11		
N20401	Quantum; Clear	17.00" (43.2cm) ²
N20403	Quantum; Clear	14.00" (35.5cm) ²
N20404	Quantum; Dk. Tint	10.75" (27.3cm) ²
N20406	Quantum; Lt. Tint	10.75" (27.3cm) ²
N20405	Quantum; Dk. Tint	07.25" (18.4cm) ²

FLHTCU Electra Glide Ultra Classic 2014-18; FLHTK Electra Glide Ultra Limited 2014-18; FLHTCUTG Tri-Glide Ultra 2014-15; FLHX Street Glide 2014-18; FLHXS Street Glide Special 2014-18

N20407	Quantum; Clear	14.50" (39.4cm) ²
N20408	Quantum; Clear	11.50" (29.2cm) ²
N20409	Quantum; Lt. Tint	09.50" (24.1cm) ²
N20410	Quantum; Lt. Tint	07.50" (19.0cm) ²
N20411	Quantum; Dk. Tint	07.25" (18.4cm) ²

FLTR Road Glide 1998-13; FLTRU Road Glide Ultra 2010-13; FLTRX Road Glide Custom 2010-13

N20421	Quantum; Clear	18.00" (45.7cm) ¹
N20422	Quantum; Clear	15.25" (38.7cm) ¹
N20423	Quantum; Dk. Tint	09.25" (23.5cm) ¹
N20424	Quantum; Lt. Tint	09.25" (23.5cm) ¹
N20425	Quantum; Clear	12.00" (30.5cm) ¹

FLTR Road Glide 2015-18

N20431	Quantum; Clear	09.00" (22.8cm) ¹
N20432	Quantum; Clear	12.50" (31.7cm) ¹
N20433	Quantum; Dk. Tint	16.00" (40.6cm) ¹

INDIAN

Chieftain 2014-18; Roadmaster 2014-18

N20703	Quantum; Clear	TBD
N20704	Quantum; Lt. Tint	TBD
N20705	Quantum; Dk. Tint	TBD

VICTORY

Cross Country 2010-17; Cross Country Tour 2010-17; Magnum 2015-17

N20700	FMR; Clear	12.25" (31.1cm) ¹
N20701	FMR; Lt. Tint	10.25" (26.0cm) ¹
N20702	FMR; Dk. Tint	08.25" (21.0cm) ¹

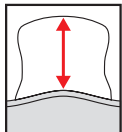

1 Centerline measurement from top of fairing edge to top of screen

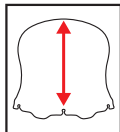

2 Centerline measurement from bottom center mount hole to top of screen



N20401 N20403 N20406 N20404 N20405



N20407 N20408 N20409 N20410 N20411



N20421 N20422 N20425 N20424 N20423



N20431 N20432 N20433



All FLTR VStream[®] Windscreens include metal compression limiters that spread the load for long life and durability.



Quantum[®] Hardcoated Lexan[®] Polycarbonate

Developed for windshield use by National Cycle, Quantum hardcoating takes motorcycle windshields a quantum leap forward in scratch resistance and out-door life. The durability of polycarbonate combined with Quantum hardcoating produces the strongest, most scratch resistant windshield available.



FMR Hardcoated Lexan[®] Polycarbonate

The strength of polycarbonate combined with FMR hardcoating provides strength with good scratch resistance. FMR polycarbonate is the OEM motorcycle industry standard and was first developed for the motorcycle industry by National Cycle.



National Cycle 3-Year Warranty

Our exclusive 3-Year Warranty covers all National Cycle polycarbonate windshields and windshields against breakage.



Welcome To ZTechnik Worldwide

ZTechnik was formed in 2000 to provide BMW dealerships with windscreens and accessories of OEM quality. Over the years, the ZTechnik brand has gained worldwide recognition, and our mission remains the same.

ZTechnik products are designed, engineered and manufactured by National Cycle, Inc. in the U.S.A. Our windscreen line is the finest you can provide to your customers. We start with the best materials and incorporate our state-of-the-art manufacturing. Check out the bracket systems for naked F- and R-Series motorcycles. Each system is engineered directly on the bike for a motorcycle-specific OEM fit and finish.

At ZTechnik, we think about every product from the rider's perspective. We measure the value of any accessory by how it increases the rider's enjoyment and whether it gives him or her more confidence and ability on the road.

ZTechnik is releasing new products almost every month of the year! This new catalog provides a format for you to showcase all ZTechnik's products, new offerings and up-to-date information for riders worldwide.

Some of the icons used throughout this catalog you will recognize as ZTechnik trademarks. A detailed explanation for all the icons is given in the beginning pages. Familiarize yourself with them and you'll be able to quickly supply the enthusiast with much of their needed product information.

We get constant feedback from dealers and customers for new products and features. The ZTechnik Engineering and Production Teams are working hard to bring these to you and your customers!

Thank you for your support, and good riding!

GETTING AROUND

WINDSCREENS
AND ACCESSORIES

R SERIES GS

The tab on each page defines the ZTechnik® product category...

...while the color denotes a BMW® model series:

-  R Series
-  K Series
-  S Series
-  F Series
-  G Series
-  C Series
-  Multi-Fit

Welcome To ZTechnik Worldwide



We are pleased to bring you this accessory catalogue and welcome you to the ZTechnik product line. ZTechnik, a division of National Cycle, Inc., specializes in high quality, innovative accessories for BMW Motorcycles.

The name itself, ZTechnik, is from the German "Zubehör Technik," which roughly translates to "technical accessories" in English. The philosophy of ZTechnik is to adhere to strict standards to produce only the highest quality accessories possible in order to enhance the rider's total experience.

Come ride with us, and you will experience the spark that drives a product into the design phase. It's not where we hang our helmets that these accessories are born... they find a place onto the pages of this catalogue after many miles of riding and talking with other BMW riders. The riders, the roads, and the experiences are all very different, but the one common bond all motorcyclists seem to share is the innate urge to mold their bike to themselves.

As great as the machines are, riders need products and accessories to solve problems, to carry gear, or simply for the fun of customizing their motorcycle, for making their bike unique.

We would like ZTechnik to augment your needs when it comes time to make your BMW motorcycle special. Our highly trained, technically skilled staff is at your service with our latest innovative products designed to enhance your enjoyment of riding.

Good Riding!

Barry Willey
President, National Cycle, Inc.

BINDER CONTENTS

- Introduction and Materials Guide
- Windscreens and Windscreen Accessories
- Appearance and Trim
- Touring, Comfort and Convenience
- ZTechnik Accessory Mounts and Adapters
- Applications and Pricing

MATERIAL ICONS



Developed for motorcycle windscreen use by National Cycle, **Quantum® hardcoating** takes a quantum leap forward in scratch resistance, superb optics and long outdoor life. National Cycle and ZTechnik apply this crystal clear hardcoating to thick gauged polycarbonate material. The combined result is the strongest, most scratch resistant windscreen material available worldwide.



Lexan® polycarbonate windscreens with FMR hardcoating provide unbeatable strength, excellent optical quality, and extremely good scratch resistance. Lexan FMR polycarbonate is the OEM motorcycle industry standard and was originally introduced to the motorcycle industry by National Cycle, Inc.



High strength **Stainless Steel** material is extremely resistant to corrosion and will not fatigue under weight bearing, high stress loads. Finish varies depending on product.



High strength **Steel** material will not fatigue with weight bearing and high stress loads. Finish varies depending on product.



Our **Machined Aluminum** products are impressively milled and solidly constructed. Available in several anodized finishes.



Cast Metal, a time-honored method of pouring hot metal into a mold, enables us to create complex and multi-dimensional designs.

OTHER ICONS



All Hardware and Fasteners Included that are required to mount the item. Supplemental hardware may be required for certain models as noted in our application chart.



Uses Existing Mounting Hardware and requires no supplemental fasteners.



An exclusive **3-Year Warranty** covers all registered ZTechnik polycarbonate windscreens against breakage.



ABE Approved for German homologation. All ZTechnik windscreens are U.S. DOT approved as well.



ABE Pending. U.S. DOT approved.



New Products are identified with this icon at the top of each page.

Quantum® is an exclusive product and a trademark of National Cycle, Inc., Maywood, IL USA.

VStream® is a registered trademark of National Cycle, Inc., Maywood, IL USA and is covered by patent #7387328.

Motorcycle model names and designations are trademarks of BMW AG and are used for reference only.

Lexan® is a registered product of SABIC.



POLYCARBONATE... OR ACRYLIC? YOU DECIDE!

When you watch ZTechnik's online video demonstration, you'll see why they manufacture their windscreens from thick Lexan® polycarbonate material. There is simply nothing else that stands up to its strength and durability.



Compared to standard acrylic windshields, polycarbonate is **20X more impact resistant** and **23X more crack resistant**. That's performance you can feel comfortable riding behind!

For Quality, Value and Price, whether it's FMR or Quantum hardcoated, your polycarbonate windshield from ZTechnik will outperform any other windshield available.

"The ZTechnik® windscreen on my 2003 R1150GS Adventure saved my life recently, or at least prevented a serious highway accident.

"While I was riding on the interstate, a landscaping truck in front of me lost a 12"x12" paving tile, which struck my ZTechnik screen. I saw it coming and could do nothing but brace for the impact. The screen deflected under the weight and velocity of the paving tile, but did not break or crack! I was able to maintain control and safely exit the highway to check for damage. There was none!!! Except for some scratches, as you might expect, the screen and the mounts were in good functional order.

"I will need to replace the screen due to the scratches, and I will certainly get another ZTechnik screen!

"Many thanks for the best windscreen I have ever used!"

~ Jim B.

Polycarbonate Strength

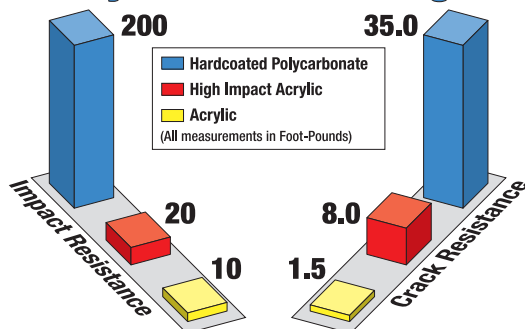

Welcome To ZTechnik Worldwide

ZTECHNIK'S QUANTUM LEAP IN WINDSCREEN HARDCOATINGS

What makes ZTechnik's z hardcoated windscreens better than all the others?

SUPERIOR SCRATCH RESISTANCE

30X more scratch resistance than typical acrylic windscreens is saying a lot! Think of it as 30X more miles per windscreen. FMR hardcoated polycarbonate is a big improvement over acrylic, yet Quantum hardcoated polycarbonate even has **10X better scratch resistance than FMR**. That's the kind of performance and strength you need from a motorcycle windscreen!

GLARE-FREE OPTICS

Think about riding into the sun – or at oncoming headlights at night – and not having to look through the glare of fine scratches that eventually show up on your screen. Quantum hardcoating gives your windscreen much better optical definition and clarity, and your windscreen will stay that way a lot longer.



On the left you'll see the motorcycle windscreen with typical surface wear, scratches and abrasions. This is NOT what you want in front of you when facing oncoming traffic!

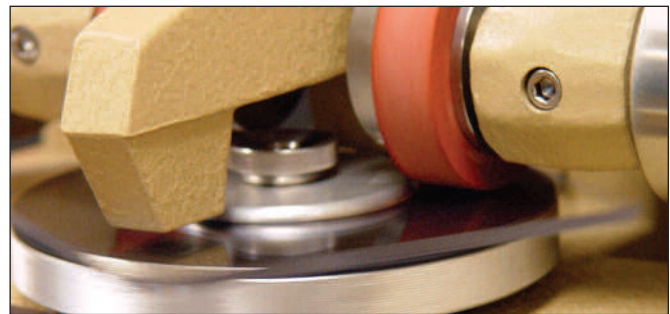

Scientific laboratory monitoring and measurement instruments, like ZTechnik's Tabor 5130 Abraser, test the surface wear on both hardcoated and uncoated windscreen materials.

AND... ZTECHNIK'S 3-YEAR UNBREAKABLE WARRANTY

We believe we make the **world's best and toughest windscreens** and we back up that commitment with a **3-Year Warranty against breakage**. If your ZTechnik polycarbonate windscreen breaks, it will be replaced free of charge! No other windscreen manufacturer makes that promise and commitment!



Welcome To ZTechnik Worldwide



THE REVOLUTIONARY VSTREAM® WINDSCREENS

HOW DOES VSTREAM WORK?

ZTechnik revolutionized windscreen performance with their VStream® windscreens. They are well known not only for superior wind-deflecting comfort but also for a riding environment that is calm and quiet. In order to create a more comfortable ride, other manufacturers offer extra-tall windscreens or spoiler tops to try to lift the air stream. But ZTechnik designed, for the first time ever, a windscreen with contours calculated and adjusted to manage the riding environment.

QUIET

The airflow pattern of the wake from most windscreens is called a *van Karman vortex*. At speeds of 50-90 mph, the air swirls off the windshield in an approximate 90-degree rotational vortex. It then hits the bottom of the rider's neck on the way up, and curves off the shoulders at approximately 45 degrees. The VStream is named for its unique patented "V" shape. This design **quiets the ride** because it pushes that vortex out and away from the side of the rider's head, reducing irritating wind noise.

COMFORT

The VStream's advanced "V" profile, unique three-dimensional contours, and smooth radiused edges all contribute to **calmness and comfort** in the riding environment. Unsettling wind turbulence is effectively pushed aside, and this fatigue-reducing experience is greatly appreciated by the rider and passenger. Many satisfied customers claim the VStream is definitely the most comfortable windscreen they've owned.

DURABILITY AND OPTICAL CLARITY

In addition, VStream windscreens have an outstanding level of **durability and optical clarity** that is the result of over 73 years of windscreen manufacturing and advanced technology in forming and coating. Experience the VStream windscreens and see why they are **the most comfortable windscreen you can ride behind** on a BMW® motorcycle.

STATE-OF-THE-ART VSTREAM+® WINDSCREENS

WHAT IS VSTREAM+?

VStream+ windscreens are special **bracket mounted screens utilizing custom designed, highly engineered and perfectly manufactured mount systems**. Some models come from the factory with no provision for mounting a windscreen, while others will accommodate only very small screens that have little effective wind protection value.

ZTechnik believes that if a rider wants a touring windscreen for his or her bike, there should be nothing standing in the way.

VStream+ mounting brackets, included with the windscreen, are a custom fit for each model bike. They're easy to install, require no modifications to existing components, and add strength and rigidity to the windscreen mounting points.

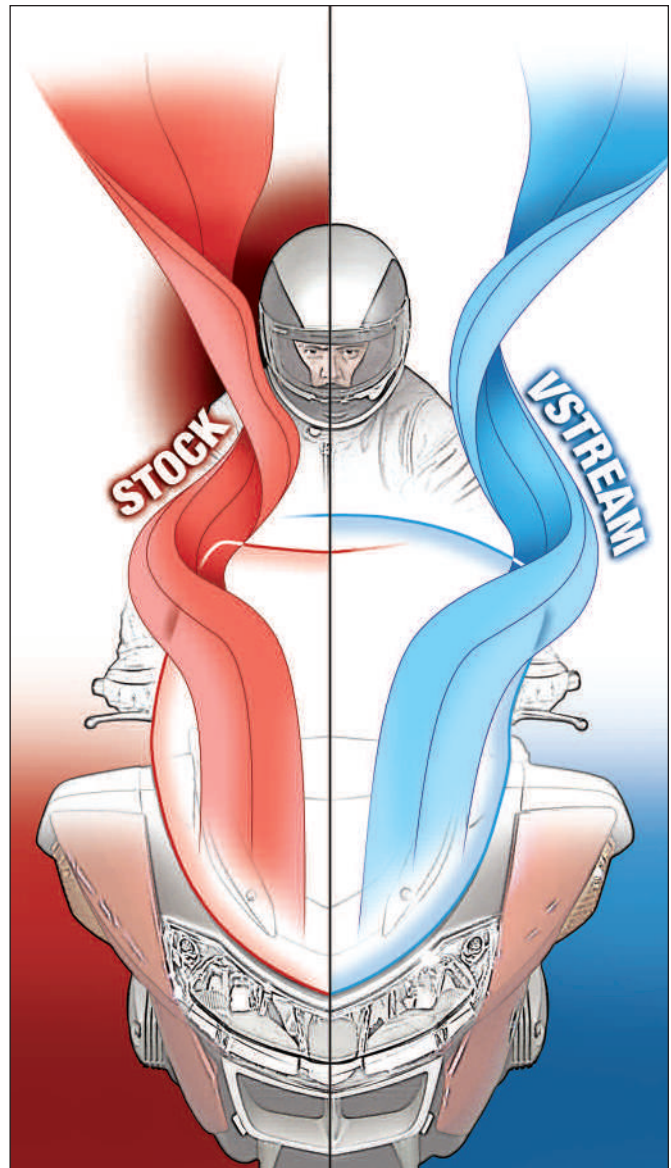
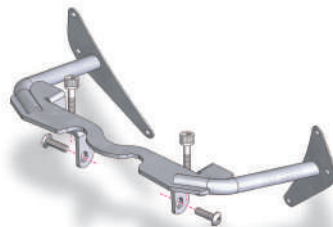

"It's clear that your Z2402 VStream® Windscreen for the R1200RT is well thought out and fabricated. No issues with the installation and it meets all my expectations. Been on long and short rides. I'm pleased with the operation, and the extra height and width provide a better comfort envelope during the ride than the stock screen. While I normally wear ear plugs under my helmet, it is also nice to be able to remove much of the wind noise by raising the screen higher. I've even had a chance to brag on it to several other RT riders who are looking at options for their own machines."

~ Mike F.

"I purchased a Z2450 VStream® Windscreen for my K1200LT while I was at the 2007 BMWMOA National Rally in West Bend, WI.

"I have enjoyed having this windshield on my bike as there is much less wind turbulence and much better visibility than with the stock BMW windshield. I am looking forward to many comfortable miles with this VStream windshield on my bike."

~ Charles J.



Z2488 VStream Touring Deluxe Windscreen shown on a 2016 R1200GS Adventure.

VStream Windscreens

- Z2485 Sport Windscreen
- Z2486 Sport Windscreen
- Z2487 Touring Windscreen
- Z2488 Touring Deluxe Windscreen

Fits 2013-16 R1200GS and 2014-16 R1200GS Adventure.

ZTechnik has the VStream solution for the new GS water boxers!

Even the small-sized Z2485 and Z2486 sport versions put the windscreen shape where it's needed most for taming turbulent airflow.

The taller Z2487 Touring Windscreen offers a perfect solution for GS riders who travel long and far. The Z2488 Touring Deluxe is for the dedicated Iron Butt riders. Factory height adjustment is maintained for all sizes.

Like all ZTechnik polycarbonate windscreens, they're covered by an exclusive 3-Year Warranty against breakage.

NOTE: We recommend the Z5220 Windscreen Stabilizer Kit for the tall Z2488. See the **Windscreen Accessories** section for more information.

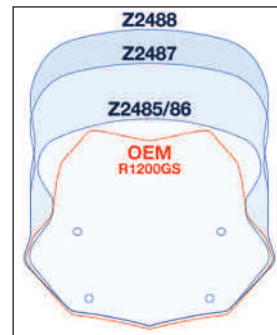

Specifications and Materials

	Z2485/86	Z2487	Z2488
H:	15.50" (39.3cm)	19.50" (49.5cm)	22.00" (55.9cm)
W:	14.25" (36.2cm)	15.25" (38.7cm)	15.75" (40.0cm)
Color:	Dark Tint/Clear	Clear	Clear

4.5mm Polycarbonate with FMR Hardcoating; ZTechnik 3-Year Warranty Against Breakage; Uses Existing Hardware; DOT/ABE Approved

VStream+® Windscreens for 2004-12 R1200GS



WINDSCREENS
AND ACCESSORIES

R SERIES GS

Z2415A



VStream Windscreen with Accessory Shelf

Z2415A VStream Windscreen

Fits 2004-13 R1200GS (Oilcooled).

These VStream Windscreens are the premier wind management performers for the R1200GS! The comfort, clarity and durability are a great upgrade.

A unique lateral bracket adds torsional rigidity and includes an integrated accessory shelf with cutouts to mount standard BMW power outlets for connecting electronic accessories. Factory rake adjustment is retained.

All ZTechnik polycarbonate windscreens are backed by an exclusive 3-Year Warranty against breakage.

NOTE: Z2415A require the use of ZTechnik Z5300 Mirror Extenders for proper clearance.



ZTechnik's innovative VStream® gets its name from the unique shape and dimensional contours designed and engineered into the windscreen. The patented "V" profile helps push turbulent air out and away, producing a quieter and more comfortable riding experience for both the rider and the passenger.

Specifications and Materials



Z2415A
H: 19.38" (49.2cm)
W: 19.00" (48.2cm)
Color: Clear



4.5mm Polycarbonate with FMR Hardcoating;
ZTechnik 3-Year Warranty Against Breakage;
All Hardware Included; DOT/ABE Approved



ZTechnik's Z5200 LeverAction™ Rake Adjust Kit works with this windscreen! See the Windscreen Accessories section for details.



Touring Windscreen for 2004-12 R1200GS

WINDSCREENS
AND ACCESSORIES

R SERIES GS

Z2242



Touring Windscreen

Z2242 Touring Windscreen

Fits 2004-12 R1200GS.

This windscreen, 3.00" taller and 4.00" wider than the stock screen, is designed for excellent wind and weather protection with substantially improved airflow. The Z2242 utilizes the BMW rake adjust mount points, which remain fully operational.

All polycarbonate replacement windscreens are backed by ZTechnik's 3-Year Warranty against breakage.

Specifications and Materials



Z2242
H: 16.00" (40.6cm)
W: 18.00" (45.7cm)
Color: Clear



4.5mm Polycarbonate with FMR Hardcoating;
ZTechnik 3-Year Warranty Against Breakage;
Uses Existing Hardware; DOT/ABE Approved

ZTechnik's Z5200 LeverAction™ Rake Adjust Kit works with this windscreen! See the Windscreen Accessories section for details.

VStream+® Windscreens for 2006-13 R1200GS Adventure



WINDSCREENS AND ACCESSORIES
R SERIES GS



VStream Windscreens

- Z2416** VStream Tall Touring Windscreen
- Z2418** VStream Extra Tall Touring Windscreen
- Z2420** VStream Sport Touring Windscreen

Fits 2006-13 R1200GS Adventure.

The touring sized Z2416 windscreen, 3.00" taller than stock, brings VStream comfort, performance and durability to the R1200GS Adventure. The extra tall Z2418 windscreen is a full 5.00" taller than stock, and is made specially for taller riders or those who want maximum wind protection. The sportier, more compact Z2420 (1.00" taller) brings the VStream experience to the aggressive R1200GS Adventure rider.

On all VStream windscreens for the R1200GS Adventure, the factory rake adjustment is retained for a wide range of individual comfort settings.

All ZTechnik polycarbonate windscreens are backed by an exclusive 3-Year Warranty against breakage.

NOTE: These VStream Windscreens require the use of ZTechnik Z5303 Mirror Extenders for proper clearance.

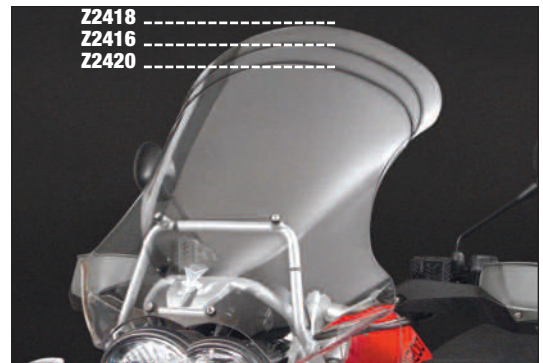

ZTechnik VStream Windscreens for the R1200GS Adventure are available in three different heights so riders can tailor their wind protection and comfort needs to their style of riding.

Specifications and Materials

	Z2416	Z2418	Z2420
H:	21.00" (53.4cm)	23.00" (58.5cm)	19.00" (48.2cm)
W:	16.80" (42.7cm)	18.50" (47.0cm)	15.60" (39.6cm)
Color:	Clear	Clear	Clear



4.5mm Polycarbonate with FMR Hardcoating;
ZTechnik 3-Year Warranty Against Breakage;
Uses Existing Hardware; DOT/ABE Approved



ZTechnik's Z5202 LeverAction™ Rake Adjust Kit works with this windscreen! See the Windscreen Accessories section for details.



VStream+® Windscreens for 2002-05 R1150GS Adventure

WINDSCREENS
AND ACCESSORIES

R SERIES GS



Includes rugged 5/8" steel frame bracket for solid and secure 4-point mounting. The Z6408 ZTechnik Accessory Mount (shown) can be attached to the windshield bracket, leaving the handlebars unweighted and unencumbered.

VStream Windscreens

Z2422 VStream Tall Touring Windscreen

Z2423 VStream Sport Touring Windscreen

Fits 2002-05 R1150GS Adventure.

Up-to-date VStream style, durability and performance are made for your R1150GS Adventure. This windscreen's rugged 5/8" steel lateral bracket adds stability and strength with two additional mount points for solid and secure 4-point mounting.

The Z2422 measures 3.50" taller than stock, and is geared for touring and wind protection. The Z2423 is a standard height screen but adds extra width. This is a great choice as an everyday windscreen.

Like all ZTechnik polycarbonate windscreens, they're covered by an exclusive 3-Year Warranty against breakage.

The Z2422/Z2423 mounting bracket can also be used with our Z6408 Accessory Mount for holding radar detectors, GPS units or any other electronic accessory.

Specifications and Materials



Z2422
H: 23.00" (58.4cm)
W: 19.75" (50.2cm)
Color: Clear

Z2423
H: 20.00" (50.8cm)
W: 18.00" (45.7cm)
Color: Light Tint



4.5mm Polycarbonate with FMR Hardcoating;
ZTechnik 3-Year Warranty Against Breakage;
Uses Existing Hardware; DOT Approved, ABE Pending

VStream+® Windscreens for 1993-98 R850/1100GS



WINDSCREENS
AND ACCESSORIES

R SERIES GS

Z2437



Z2438



VStream Windscreens

Z2437 VStream Tall Touring Windscreen

Z2438 VStream Sport Touring Windscreen

Fits 1993-98 R850/1100GS.

Up-to-date VStream style, durability and performance are what you need for the original R1100GS. These replacement windscreens offer a solid and secure fit with outstanding performance. The special mounting brackets maintain factory rake adjustment capability for a wide range of individual comfort settings.

The Z2437 is a great choice for long distance touring or maximum wind protection. The Z2438 is the perfect everyday, around-town windscreen.

Like all ZTechnik polycarbonate windscreens, they're covered by an exclusive 3-Year Warranty against breakage.

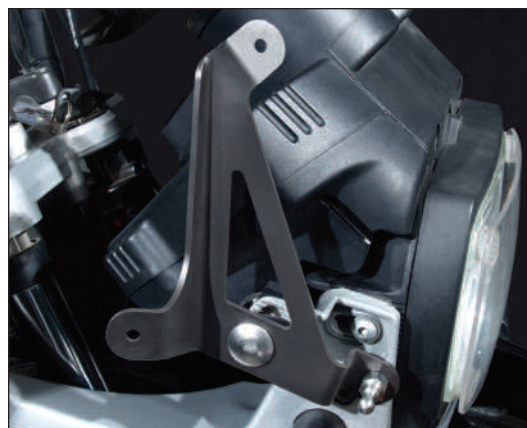

The sturdy, powdercoated mounting brackets maintain OEM rake adjustments and offer solid 6-point mounting. It's rugged hardware for a rugged bike.



Specifications and Materials



Z2437
H: 20.75" (52.7cm)
W: 18.00" (45.7cm)
Color: Clear

Z2438
H: 17.75" (45.1cm)
W: 17.50" (44.5cm)
Color: Clear



4.5mm Polycarbonate with FMR Hardcoating;
ZTechnik 3-Year Warranty Against Breakage;
Uses Existing Hardware; DOT Approved, ABE Pending



Touring Windscreens for 1999-03 R850GS/R1150GS

WINDSCREENS
AND ACCESSORIES

R SERIES GS

Z2240



Z2241



Touring Windscreens

- Z2240 Tall Touring Windscreen**
- Z2241 Sport Touring Windscreen**

Fits 1999-03 R850GS/R1150GS.

Take away irritating wind noise, fatigue, debris, and rain with the Z2240 Tall Replacement Screen. With 7.75" of increased height, it will smooth out wind turbulence, protect you from the elements, and offer a viewing area with superior optical quality.

The Z2241 is a sportier version of the Z2240, but still wider and 4.00" taller than the stock windscreen for a significant improvement in wind protection. Like the Z2240, it features polycarbonate strength and excellent optics.

All ZTechnik polycarbonate windscreens are backed by an exclusive 3-Year Warranty against breakage.

When you watch our online video demonstration, you'll see why we manufacture our windscreens from thick Lexan® polycarbonate material. There is simply nothing else that stands up to its strength and durability. Compared to standard acrylic windscreens, polycarbonate is 20X more impact resistant and 23X more crack resistant. That's performance you can feel comfortable and secure riding behind!

All ZTechnik windscreens are Quantum® or FMR hardcoated to give you superior scratch resistance. The type of hardcoat applied will depend on the size and design of windscreen.

For Quality, Value and Price, whether FMR or Quantum hardcoated, your polycarbonate windscreen from ZTechnik will outperform any other windscreen available.

Specifications and Materials

	Z2240	Z2241
	H: 21.75" (55.2cm) W: 18.50" (47.0cm) Color: Clear	H: 18.00" (45.7cm) W: 18.00" (45.7cm) Color: Light Tint

4.5mm Polycarbonate with FMR Hardcoating; ZTechnik 3-Year Warranty Against Breakage; Uses Existing Hardware; DOT/ABE Approved

VStream+® Windscreens

for 2015-16 R1200R

NEW



WINDSCREENS
AND ACCESSORIES

R SERIES R

Z2353

Z2354

Z2355



VStream Windscreens

- Z2353** VStream Sport Windscreen
- Z2354** VStream Sport Touring Windscreen
- Z2355** VStream Tall Touring Windscreen

Fits 2015-16 R1200R.

ZTechnik offers three great VStream windscreens for the liquid-cooled R1200R! Choose the tint and size that suits your riding style and wind protection needs.

All three sizes feature integrated lower deflectors to reduce turbulence and backdrafts. They make your windscreen function like a fairing, and make your riding experience more comfortable.

These windscreens include a highly engineered, super-strong mounting bracket that integrates perfectly with the design of the bike.

All three sizes work with either U.S.A. or European market turn signals.

All ZTechnik polycarbonate windscreens are backed by an exclusive 3-Year Warranty against breakage.

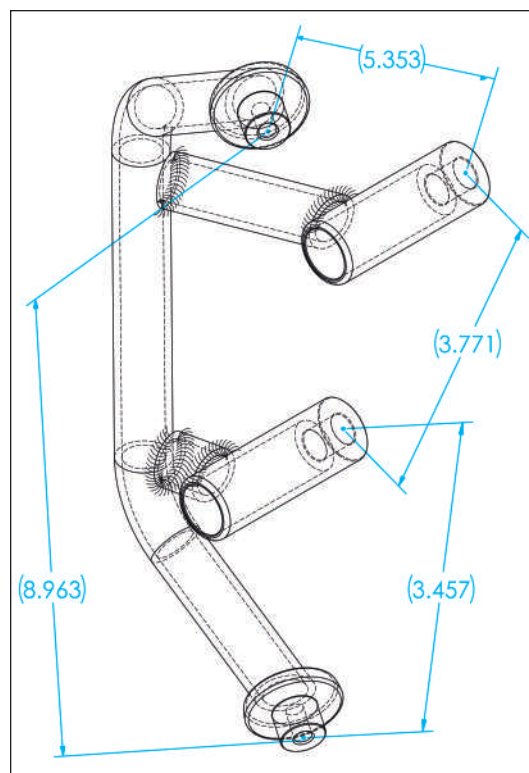

Specifications and Materials

Z2353	Z2354	Z2355
H: 15.75" (40.0cm)	H: 20.50" (52.0cm)	H: 23.88" (60.6cm)
W: 17.25" (43.8cm)	W: 20.50" (52.0cm)	W: 20.50" (52.0cm)
Color: Dark Tint	Color: Light Tint	Color: Clear

Sophisticated engineering and computer aided design and manufacturing go into every VStream+ mounting system to ensure perfect fit and superior strength.



4.5mm Polycarbonate with FMR Hardcoating;
ZTechnik 3-Year Warranty Against Breakage;
All Hardware Included; DOT/ABE Approved



VStream+® Windscreens for 2011-14 R1200R

WINDSCREENS
AND ACCESSORIES

R SERIES R



These windscreens utilize our custom-designed, lightweight and extremely strong 6-point mounting brackets. These are the best R1200R mount brackets made!

VStream Windscreens

- Z2443** VStream Sport Windscreen
- Z2442** VStream Sport Touring Windscreen
- Z2444** VStream Tall Touring Windscreen

Fits 2011-14 R1200R.

ZTechnik offers three state-of-the-art VStream windscreens for the R1200R! Choose the tint and size that suits your riding style and wind protection needs.

The Z2442 and Z2444 feature integrated lower deflectors to reduce turbulence and backdrafts. They make your windscreen function like a fairing, and make your riding experience more comfortable.

These windscreens include a highly engineered, super-strong mounting bracket that integrates perfectly with the bike's upper triple clamp.

All three sizes work with either U.S.A. or European market turn signals.

All ZTechnik polycarbonate windscreens are backed by an exclusive 3-Year Warranty against breakage.

Specifications and Materials



Z2443
 H: 14.00" (35.5cm)
 W: 18.00" (45.7cm)
 Color: Dark Tint

Z2442
 H: 18.50" (47.0cm)
 W: 18.00" (45.7cm)
 Color: Light Tint

Z2444
 H: 22.50" (57.1cm)
 W: 18.25" (46.3cm)
 Color: Clear



**4.5mm Polycarbonate with FMR Hardcoating;
ZTechnik 3-Year Warranty Against Breakage;
All Hardware Included; DOT/ABE Approved**

VStream+® Windscreens for 2006-10 R1200R



WINDSCREENS
AND ACCESSORIES

R SERIES R

Z2405



Z2406



VStream Windscreens

Z2405 VStream Windscreen (US)

Z2408 VStream Windscreen (Euro)

Fits 2006-10 R1200R.

ZTechnik adds a world of VStream sport touring comfort to the versatile R1200R. This windscreen includes a highly engineered, super-strong mounting system that integrates with the triple clamp and the handlebar controls.

The Z2405, 5.50" taller than the OEM accessory screen, fits U.S. models only. The Z2408 is same size screen for the European model R1200R.

Z2406 Tall VStream Windscreen (US)

Z2409 Tall VStream Windscreen (Euro)

Fits 2006-10 R1200R.

The Z2406 VStream is a taller – 7.50" more than the OEM accessory screen – and wider version of the Z2405, for the rider who wants a bigger screen or sits taller in the saddle.

The Z2406 fits U.S. models only. The Z2409 is same size screen for the European model R1200R.

All ZTechnik polycarbonate windscreens are backed by an exclusive 3-Year Warranty against breakage.

Specifications and Materials



Z2405/Z2408
H: 18.50" (47.0cm)
W: 18.75" (47.6cm)
Color: Light Tint

Z2406/Z2409
H: 21.50" (54.6cm)
W: 21.00" (53.3cm)
Color: Light Tint



4.5mm Polycarbonate with FMR Hardcoating;
ZTechnik 3-Year Warranty Against Breakage;
All Hardware Included; DOT/ABE Approved

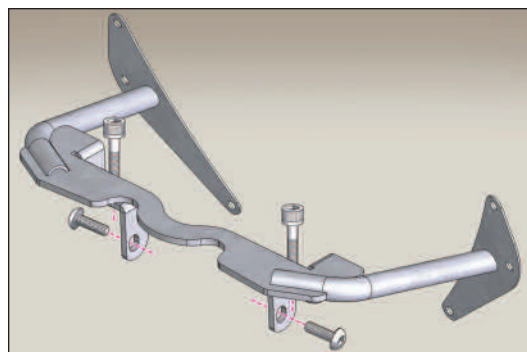

This windscreen includes a highly engineered, super-strong mounting bracket that integrates perfectly with the bike's upper triple clamp.

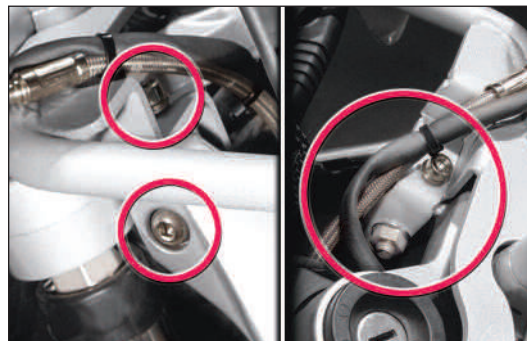

This windscreen's special mounting bracket uses quality high strength fasteners and is designed for clear and unobstructed cable passage.



Touring Windshields for 2001-06 R1150R/Rockster

WINDSCREENS
AND ACCESSORIES

R SERIES R



Touring Windshields

Z2332 Touring Windshield

Fits 2001-06 R1150R.

This superb screen and its sturdy mount system were designed and developed to fit perfectly to the R1150R. The tall touring size gives excellent performance and protection for long distance riding or cold weather commuting.

Z2335 Sport Touring Windshield

Fits 2003-06 R1150R Rockster.

This is a premium quality sport/touring windshield for the R1150R Rockster. Attractive alloy mounting brackets (included) bolt on without modifications to the Rockster's distinctive headlight and instrument cluster. A generous 20.5" height gives excellent wind protection.

Both of these polycarbonate windscreens are backed by ZTechnik's 3-Year Warranty against breakage.

The aerodynamic shape is designed to integrate perfectly with the contours of the Rockster's bodywork. A solidly mount system (included) adds stiffness and stability at high speeds.

Specifications and Materials



Z2332
H: 20.25" (51.5cm)
W: 17.50" (44.5cm)
Color: Clear



Z2335
H: 17.00" (43.2cm)
W: 20.50" (52.0cm)
Color: Light Tint



4.5mm Polycarbonate with FMR Hardcoating;
ZTechnik 3-Year Warranty Against Breakage;
All Hardware Included; DOT/ABE Approved

VStream® Windscreens for 2015-16 R1200RS

NEW



WINDSCREENS
AND ACCESSORIES

R SERIES RS

Z2373

Z2374

Z2375



VStream Windscreens

Z2373 VStream Sport Windscreen

Z2374 VStream Sport Touring Windscreen

Z2375 VStream Tall Touring Windscreen

Fits 2015-16 R1200RS.

Starting with the original groundbreaking R100RS and through the R1150RS, the RS models were legendary in BMW's product line. Now sport touring enthusiasts everywhere welcome back the RS platform with the new R1200RS.

ZTechnik® has designed new VStream® Windscreens in three sizes and tints for the new R1200RS. Three sizes means there is a perfectly proportioned windscreen for almost every rider. All will offer improved wind protection and riding comfort compared to other aftermarket windscreens.

Like all ZTechnik polycarbonate VStream Windscreens, they're covered by ZTechnik's exclusive 3-Year Warranty against breakage.



Complete OEM height adjustability is maintained along with full left/right steering lock clearances.

Specifications and Materials



Z2373
H: 16.00" (40.6cm)
W: 17.63" (44.7cm)
Color: Dark Tint

Z2374
H: 19.00" (48.3cm)
W: 18.50" (47.0cm)
Color: Light Tint

Z2375
H: 22.00" (55.9cm)
W: 19.00" (48.2cm)
Color: Clear



4.5mm Polycarbonate with FMR Hardcoating;
ZTechnik 3-Year Warranty Against Breakage;
All Hardware Included; DOT/ABE Approved



VStream® Windscreens for 2014-16 R1200RT

WINDSCREENS
AND ACCESSORIES

R SERIES R

Z2350



Z2351



Think about riding into the sun's glare, or riding at night into oncoming headlights, without having to strain to see through the reflected haze from fine scratches and abrasions on your windscreen (above left). This is not the optimal view of the road ahead for ANY rider.



ZTechnik's exclusive Quantum® hardcoating gives your windscreen much better optical definition and clarity by preventing and reducing the buildup of scratches and abrasions.

Quantum delivers 30X more scratch resistance than typical acrylic material, and even 10X more than the standard FMR hardcoated polycarbonate!

With Quantum hardcoating, your windscreen will be clearer and will stay that way a lot longer. That's the kind of performance and strength you need in a motorcycle windscreen.

VStream Windscreens

Z2350 VStream Windscreen

Z2351 VStream Tall Windscreen

Fits 2014-16 R1200RT.

The first accessory you'll want to buy for your new 2014 R1200RT Water Boxer is a ZTechnik VStream Windscreen! Consider it an investment that pays dividends in riding enjoyment.

The Z2350 measures 1.50" taller than stock, while the Z2351 measures a full 3.50" taller than stock for taller riders or for those wanting extra wind protection.

ZTechnik's exclusive Quantum® hardcoated polycarbonate gives you unbeatable scratch resistance with unmatched strength and durability.

Both of these polycarbonate windscreens are backed by ZTechnik's 3-Year Warranty against breakage.

Specifications and Materials

	Z2350 H: 25.00" (63.5cm) Color: Clear	Z2351 H: 27.00" (68.6cm) Color: Clear
---	--	--



4.5mm Polycarbonate with Quantum Hardcoating;
ZTechnik 3-Year Warranty Against Breakage;
Uses Existing Hardware; DOT/ABE Approved

VStream® Windscreens for 2005-13 R1200RT



WINDSCREENS
AND ACCESSORIES

R SERIES RT

Z2402

Z2403



VStream Windscreens

Z2402 VStream Windscreen

Z2403 Extra Tall VStream Windscreen

Fits 2005-13 R1200RT.

The Z2402 will be the most versatile and appreciated wind management accessory you will ever purchase. It's so quiet, even your passenger will be able to hear the radio. Every rider who has taken the Z2402 for a test ride comes back and makes the switch – to VStream!

The Z2402 measures 1.50" taller than stock, while the Z2403 measures a full 3.50" taller than stock for taller riders or for those wanting extra wind protection.

The taller screen features a relief vent cutout to equalize the backpressure caused by extra-large screens, where still air behind the screen creates a low pressure area, causing fast moving turbulent air to rush in. This relief vent reduces buffeting on the back of the rider's helmet.

ZTechnik's exclusive Quantum® hardcoated polycarbonate gives you unbeatable scratch resistance with unmatched strength and durability.

Both of these polycarbonate windscreens are backed by ZTechnik's 3-Year Warranty against breakage.

Specifications and Materials



Z2402
H: 26.00" (66.0cm)
W: 24.75" (62.9cm)
Color: Clear

Z2403
H: 28.00" (71.1cm)
W: 26.00" (66.0cm)
Color: Clear



4.5mm Polycarbonate with Quantum Hardcoating;
ZTechnik 3-Year Warranty Against Breakage;
Uses Existing Hardware; DOT/ABE Approved

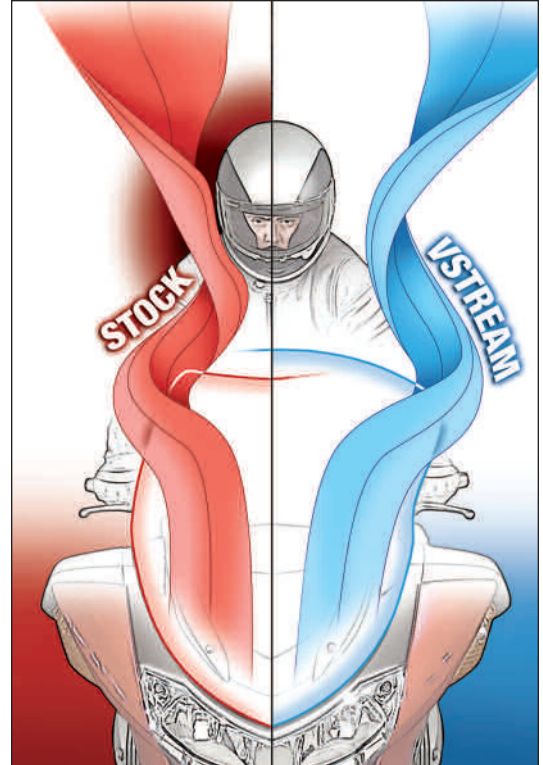

ZTechnik's innovative VStream® gets its name from the unique shape and dimensional contours designed and engineered into the windscreen.

The patented "V" profile helps push turbulent air out and away, producing a quieter and more comfortable riding experience for both the rider and the passenger.



VStream® Windscreens for 1994-04 R1100/1150RT

WINDSCREENS
AND ACCESSORIES

R SERIES RT

Z2400/Z2401

Z2400/Z2401 in
fully raised
position



Think about riding into the sun's glare, or riding at night into on-coming headlights, without having to strain to see through the reflected haze from fine scratches and abrasions on your windscreen (above left). This is not the optimal view of the road ahead for ANY rider.

ZTechnik's exclusive Quantum® hardcoating gives your windscreen much better optical definition and clarity by preventing and reducing the buildup of scratches and abrasions.

Quantum delivers 30X more scratch resistance than typical acrylic material, and even 10X more than the standard FMR hardcoated polycarbonate!

With Quantum hardcoating, your windscreen will be clearer and will stay that way a lot longer. That's the kind of performance and strength you need in a motorcycle windscreen.

VStream Windscreens

Z2400 VStream Windscreen

Z2456 VStream Tall Windscreen

Fits 2001-04 R1150RT.

Z2401 VStream Windscreen

Z2458 VStream Tall Windscreen

Z2459 VStream Low Windscreen

Fits 1994-00 R1100RT.

ZTechnik takes the R1150RT and R1100RT to unprecedented levels of comfort, quiet, performance and strength!

The Z2400/Z2401 VStream windscreen is 2.50" taller than stock. Your riding time on the RT will never be the same after you install this screen!

ZTechnik also offers the Z2456/Z2458 – 4.50" taller than stock – for those who are taller than the average RT pilot, or who demand maximum wind protection. If the stock R1100RT windshield height is too tall for you, try the new Z2459 VStream on your bike. You'll get superior performance and a quieter ride with VStream's patented "V" shape.

All these windscreens are made from extra-thick 6.0mm thick Quantum® hardcoated polycarbonate. This is the toughest, most impact resistant and scratch resistant windscreen you will find – anywhere!

Specifications and Materials

	Z2400/Z2401	Z2456/Z2458	Z2459
	H: 17.00" (43.2cm) W: 21.50" (54.6cm) Color: Clear	H: 19.00" (48.2cm) W: 22.00" (55.9cm) Color: Clear	H: 15.00" (38.1cm) W: 21.00" (53.3cm) Color: Clear



6.0mm Polycarbonate with Quantum Hardcoating;
ZTechnik 3-Year Warranty Against Breakage;
Uses Existing Hardware; DOT/ABE Approved

Dolphine™ Windscreen for 2001-04 R1150RS



WINDSCREENS
AND ACCESSORIES

R SERIES RS

Z2200



Sport Touring Screen

Z2220 Dolphine™ Windscreen

Fits 2001-04 R1150RS.

The Dolphine's pushed-out front bubble decreases turbulence and wind noise and increases your comfort level. Adjusted up or down, the unique laminar shape smooths out airflow, and the extra width provides a calmer air pocket. Both the rider and the passenger will enjoy a smoother, quieter ride.

The Dolphine windscreen is made from tough 4.5mm polycarbonate for excellent optics, impact resistance, and crack resistance. The FMR hard-coat gives you excellent abrasion resistance and long-term quality.

It installs easily using OEM hardware and stock windshield mount points.

Like all ZTechnik polycarbonate windscreens, it's covered by ZTechnik's exclusive 3-Year Warranty against breakage.



The Dolphine, in either the raised or lowered position, produces a clean, smooth, laminar airflow without the head-shaking turbulence and wind noise.

Specifications and Materials



Z2200
H: 13.75" (35.0cm)
W: 17.00" (43.2cm)
Color: Clear



4.5mm Polycarbonate with FMR Hardcoating;
ZTechnik 3-Year Warranty Against Breakage;
Uses Existing Hardware; DOT/ABE Approved

Polycarbonate Strength

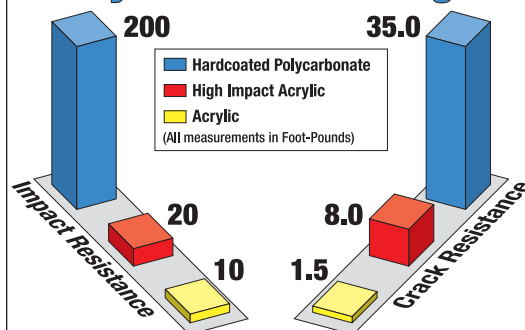



VStream® Windscreens for 1998-05 R1100S

WINDSCREENS
AND ACCESSORIES

R SERIES S



Z2440



Z2441



Think about riding into the sun's glare, or riding at night into on-coming headlights, without having to strain to see through the reflected haze from fine scratches and abrasions on your windscreen (above left). This is not the optimal view of the road ahead for ANY rider.



ZTechnik's exclusive Quantum® hardcoating gives your windscreen much better optical definition and clarity by preventing and reducing the buildup of scratches and abrasions.

Quantum delivers 30X more scratch resistance than typical acrylic material, and even 10X more than the standard FMR hardcoated polycarbonate!

With Quantum hardcoating, your windscreen will be clearer and will stay that way a lot longer. That's the kind of performance and strength you need in a motorcycle windscreen.

VStream Windscreens

Z2440 VStream Sport Touring Windscreen

Z2441 VStream Sport Windscreen

Fits 1998-05 R1100S.

R1100S riders can now have VStream's famous comfort, performance and durability along with ZTechnik's exclusive Quantum® hardcoating for unmatched scratch resistance.

Choose the tall Z2440 for all-day touring comfort, or the sportier Z2441 to maintain the look of the R1100S performance heritage.

State-of-the-art Quantum® hardcoated polycarbonate material gives these windscreens outstanding scratch resistance and impact strength unmatched by any windscreen maker worldwide. And like all ZTechnik polycarbonate windscreens, they're backed by a 3-Year Warranty against breakage.

Specifications and Materials



Z2440
H: 17.75" (45.1cm)
W: 17.25" (43.8cm)
Color: Light Tint

Z2441
H: 15.25" (38.7cm)
W: 16.50" (42.0cm)
Color: Dark Tint



4.5mm Polycarbonate with Quantum Hardcoating;
ZTechnik 3-Year Warranty Against Breakage;
Uses Existing Hardware; DOT/ABE Approved

VStream® Windscreen for 2005-08 R1200ST



Z2404

WINDSCREENS
AND ACCESSORIES

R SERIES ST



VStream Windscreens

Z2404 VStream Touring Windscreen

Fits 2005-08 R1200ST.

This windshield will convert those riders who could never imagine that the R1200ST could be such a great sport touring motorcycle!

The VStream contours of the Z2404 effectively directs wind away from your chest and shoulders.

Made from 6.0mm thick Quantum® hardcoated polycarbonate for unbeatable scratch resistance with unmatched strength and durability.

Like all ZTechnik polycarbonate windscreens, it's covered by ZTechnik's exclusive 3-Year Warranty against breakage.

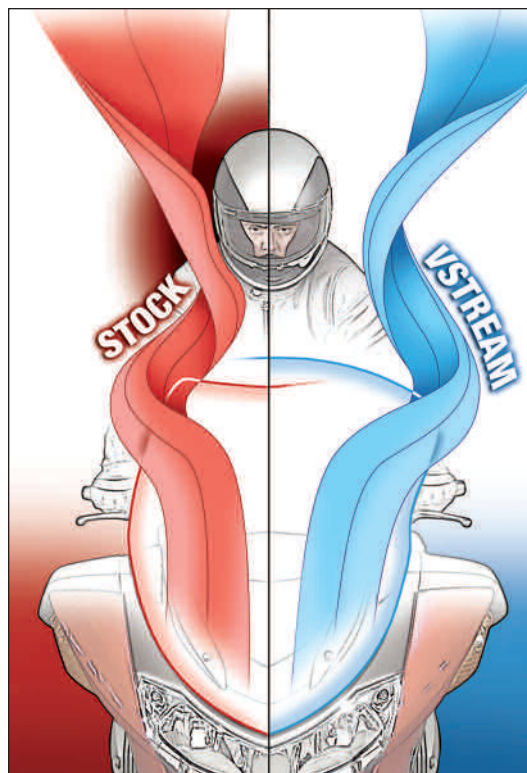

Specifications and Materials



6.0mm Polycarbonate with Quantum Hardcoating;
ZTechnik 3-Year Warranty Against Breakage;
Uses Existing Hardware; DOT/ABE Approved

ZTechnik's innovative VStream® gets its name from the unique shape and dimensional contours designed and engineered into the windscreen.

The patented "V" profile helps push turbulent air out and away, producing a quieter and more comfortable riding experience for both the rider and the passenger.



NEW VStream+® Windscreens for 2015-16 S1000XR

WINDSCREENS
AND ACCESSORIES

S SERIES XR

Z2370

Z2371

Z2372



Sophisticated engineering and computer aided design and manufacturing go into every VStream+ mounting system to ensure perfect fit and superior strength.

VStream Windscreens

Z2370 VStream Sport Windscreen

Z2371 VStream Sport Touring Windscreen

Z2372 VStream Tall Touring Windscreen

Fits 2015-16 S1000XR.

ZTechnik® now has VStream® Windscreens in three sizes and tints for the hot new crossover BMW S1000XR. Three sizes mean there is a perfectly proportioned windscreen for almost every rider. All will offer improved wind protection and riding comfort compared to other aftermarket windscreens.

Choose the VStream Sport to maintain the XR's aggressive appearance, the Tall Touring for long-distance riding, or the Sport Touring for the best of both worlds.

Like all ZTechnik polycarbonate VStream Windscreens, they're covered by ZTechnik's exclusive 3-Year Warranty against breakage.

Specifications and Materials



Z2370
H: 15.75 in. (40.0cm)
W: 16.50 in. (42.0cm)
Color: Dark Tint

Z2371
H: 18.75 in. (47.6cm)
W: 17.75 in. (45.1cm)
Color: Light Tint

Z2372
H: 21.75 in. (55.2cm)
W: 19.00 in. (48.2cm)
Color: Clear



4.5mm Polycarbonate with FMR Hardcoating;
ZTechnik 3-Year Warranty Against Breakage;
Uses Existing Hardware; DOT/ABE Approved

VStream® Windscreen **NEW** for 2014-16 S1000R



WINDSCREENS
AND ACCESSORIES

S SERIES R

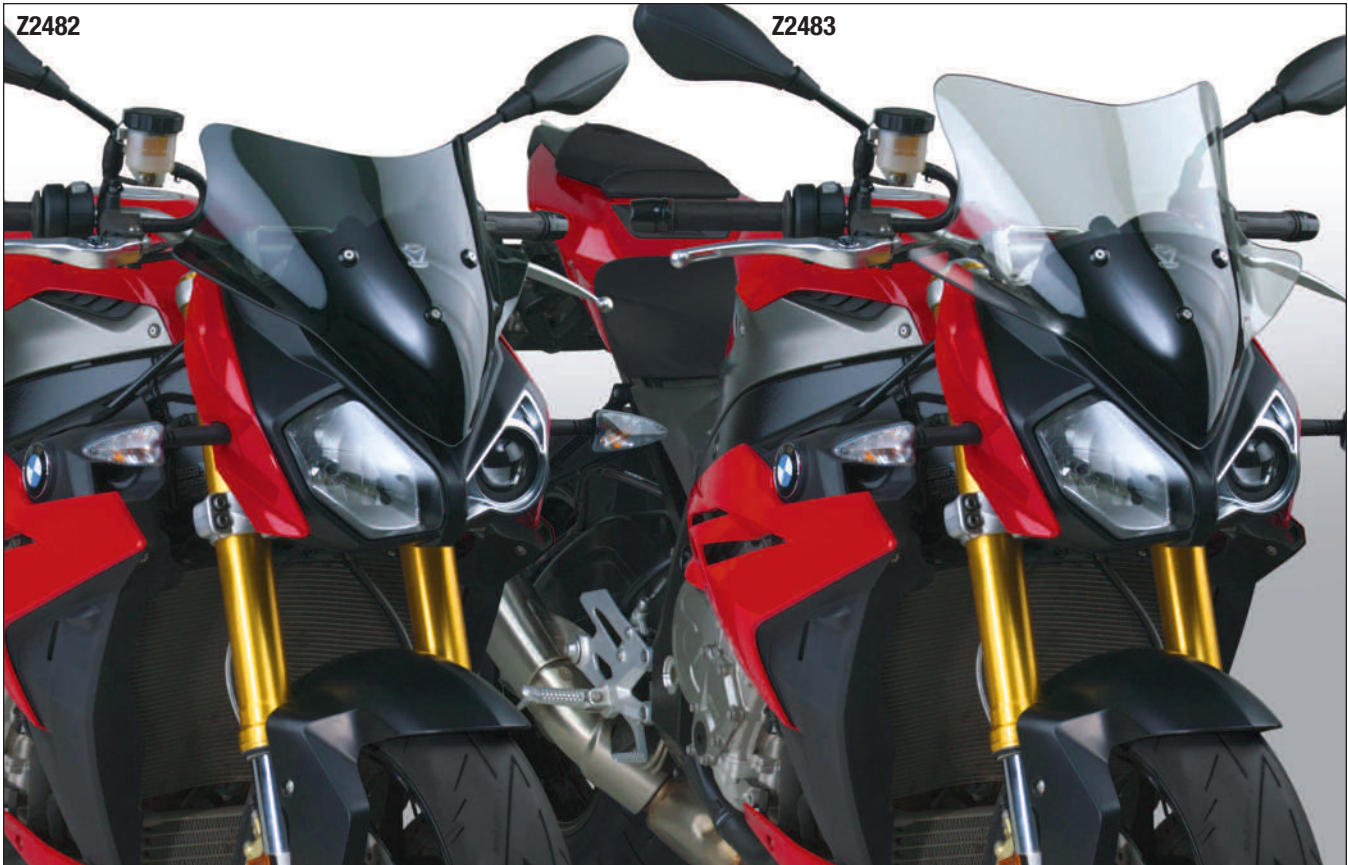

VStream Windscreens

Z2482 VStream Sport Windscreen

Z2483 VStream Sport Touring Windscreen

Fits 2014-16 S1000R.

ZTechnik offers VStream® Windscreens in two sizes and tints for the red hot BMW S1000R. Get increased wind protection without sacrificing the bike's distinctive streetfighter appearance.

The Z2482 Dark Tint VStream Sport is twice the size of the diminutive stock screen and adds functional wind protection. The Z2483 Clear Sport Touring size adds extra height and width for comfort and wind protection over long distances.

Both are backed by ZTechnik's 3-Year Warranty against breakage.

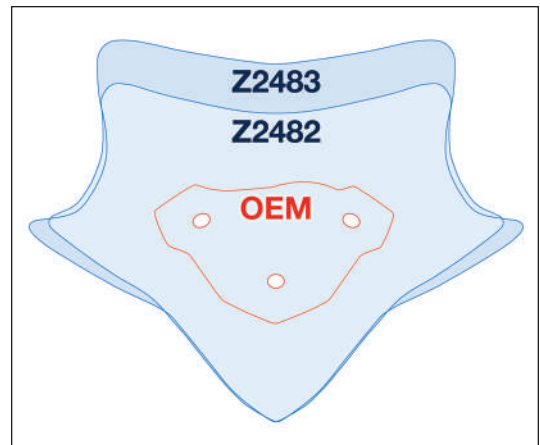

Both the Z2482 VStream Sport Windscreen and the Z2483 VStream Sport Touring Windscreen offer a big increase in performance over the tiny OEM screen.

Specifications and Materials

	Z2482 H: 12.25 in. (31.1cm) W: 16.00 in. (40.6cm) Color: Dark Tint	Z2483 H: 15.00 in. (38.1cm) W: 17.75 in. (40.0cm) Color: Light Tint
---	--	---



4.5mm Polycarbonate with FMR Hardcoating;
ZTechnik 3-Year Warranty Against Breakage;
Uses Existing Hardware; DOT/ABE Approved

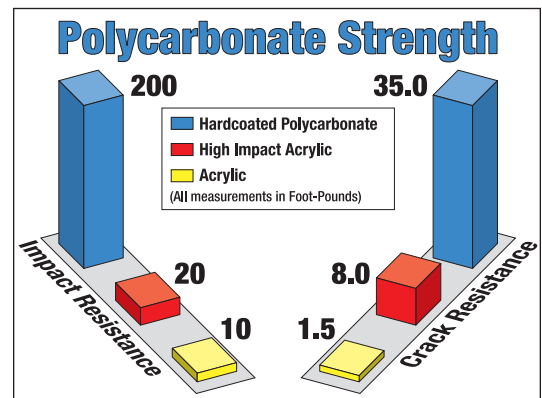



VStream® Windscreens for 2010-14 S1000RR

WINDSCREENS
AND ACCESSORIES

S SERIES RR



Z2480



Z2481



ZTechnik's VStream Windscreens offer an improvement in wind protection over the OEM screen. And, they're priced so economically that a rider can afford to get both screens – one for each side of his or her road riding personality.

VStream Windscreens

Z2480 VStream Touring Windscreen

Z2481 VStream Sport Windscreen

Fits 2010-14 S1000RR.

ZTechnik's new VStream Windscreens for the S1000RR add a whole new dimension to BMW sport touring. They let riders enjoy the bike's rip-roaring performance while adding the kind of comfort and wind protection only a VStream could offer.

The extra-tall Z2480 is the perfect choice for long cross-country days in the saddle, or for S1000RR riders who are taller than average.

The taller-than-stock Z2481 gives the S1000RR rider increased wind protection without sacrificing the bike's cutting-edge sporting appearance.

Both are backed by ZTechnik's 3-Year Warranty against breakage.

Check out the APPEARANCE AND TRIM section to see our machined aluminum ZGuards and ZCaps for the S1000RR.

Specifications and Materials



Z2480
H: 18.70 in. (47.5cm)
W: 13.50 in. (34.3cm)
Color: Clear

Z2481
H: 16.90 in. (42.9cm)
W: 13.50 in. (34.3cm)
Color: Dark Tint



4.5mm Polycarbonate with FMR Hardcoating;
ZTechnik 3-Year Warranty Against Breakage;
Uses Existing Hardware; DOT/ABE Approved

VStream® Windscreens for 2011-16 K1600GT/GTL



WINDSCREENS
AND ACCESSORIES

K SERIES GT/GTL

Z2463

Z2464



You Got the Flagship Bike... Now Get the Flagship Windscreen!

**5'11" (180cm)
Rider**

**6'3" (190cm)
Rider**

*OEM
View*

Z2463

Z2464





VStream® Windscreens for 2011-16 K1600GT/GTL

WINDSCREENS
AND ACCESSORIES

K SERIES GT/GTL

Z2463

Z2464

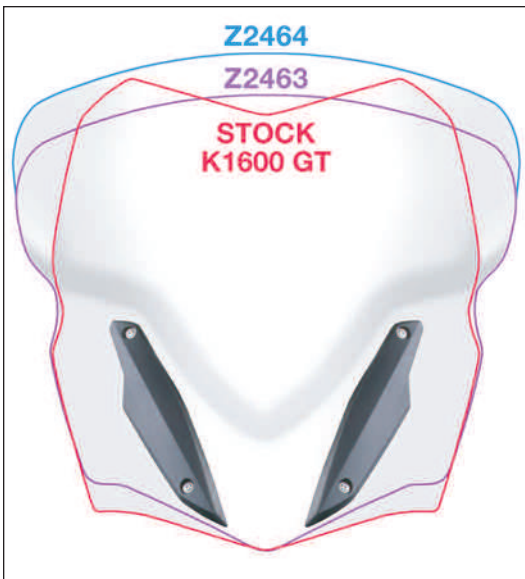

Both of these VStream Windscreens offer an improvement in wind protection over the OEM screen. Both the rider and passenger will appreciate the quiet, comfortable difference a VStream Windscreen makes.

At left: Average size riders will prefer the Z2463, while taller riders would choose the Z2464, both shown in their default position and fully raised position.

VStream Windscreens

Z2463 VStream Windscreen

Z2464 VStream Tall Windscreen

Fits 2011-16 K1600GT/GTL.

The groundbreaking K1600GT from BMW deserves nothing less than a serious windshield for riders who are serious about covering long distances.

The up-sized Z2463 is 1.00" taller and 3.25" wider than the OEM windscreen, and is perfectly proportioned for riders up to 6'0" (183cm) tall. Taller riders will appreciate the greater coverage of the Z2464 that is 3.625" taller and 3.75" wider than the OEM screen.

Both riders will find that turbulent air is deflected over their helmets, reducing wind noise and creating a pocket of calm, quiet air.

Tough 4.5mm FMR coated polycarbonate gives these VStream windscreens outstanding clarity and strength characteristics unmatched by any windscreen maker worldwide. They are 3X more resistant to abrasion than acrylic materials, and have 20X greater crack and impact resistance.

Both are covered by ZTechnik's 3-Year Warranty against breakage! (

Specifications and Materials

	Z2463	Z2464
	H: 21.00 in. (53.3cm) W: 23.50 in. (59.7cm) Color: Clear	H: 23.00 in. (58.4cm) W: 24.00 in. (61.0cm) Color: Clear
4.5mm Polycarbonate with FMR Hardcoating; ZTechnik 3-Year Warranty Against Breakage; Uses Existing Hardware; DOT/ABE Approved		

VStream® Windscreens for 2006-11 K1200/1300GT



WINDSCREENS AND ACCESSORIES
K SERIES GT

Z2452



Z2453



VStream Windscreens

Z2452 VStream Touring Windscreen

Z2453 VStream Tall Touring Windscreen

Fits 2006-11 K1200GT/K1300GT.

ZTechnik takes a great touring bike and makes it even better with the aeroacoustic VStream! All-day riding comfort comes complete with 6.0mm thick polycarbonate durability and Quantum® hardcoated scratch resistance. If you want the ultimate touring screen, this is it!

The Z2453 is a taller and wider version of the Z2452, for taller riders or for those wanting extra wind protection.

The taller screen features a relief vent cutout to equalize the backpressure caused by extra-large screens, where still air behind the screen creates a low pressure area, causing fast moving turbulent air to rush in. This relief vent reduces buffeting on the back of the rider's helmet.

State-of-the-art Quantum® hardcoated polycarbonate material gives these windscreens outstanding scratch resistance and impact strength unmatched by any windscreen maker worldwide. And like all ZTechnik polycarbonate windscreens, they're backed by a 3-Year Warranty against breakage.

Specifications and Materials



Z2452
H: 25.25" (64.1cm)
W: 23.75" (60.3cm)
Color: Clear

Z2453
H: 26.75" (67.9cm)
W: 24.00" (61.0cm)
Color: Clear



4.5mm Polycarbonate with Quantum Hardcoating;
ZTechnik 3-Year Warranty Against Breakage;
Uses Existing Hardware; DOT/ABE Approved



Think about riding into the sun's glare, or riding at night into on-coming headlights, without having to strain to see through the reflected haze from fine scratches and abrasions on your windscreen (above left). This is not the optimal view of the road ahead for ANY rider.

ZTechnik's exclusive Quantum® hardcoating gives your windscreen much better optical definition and clarity by preventing and reducing the buildup of scratches and abrasions.

Quantum delivers 30X more scratch resistance than typical acrylic material, and even 10X more than the standard FMR hardcoated polycarbonate!

With Quantum hardcoating, your windscreen will be clearer and will stay that way a lot longer. That's the kind of performance and strength you need in a motorcycle windscreen.



VStream® Windscreens for 1998-10 K1200LT

WINDSCREENS
AND ACCESSORIES

K SERIES LT

Z2450

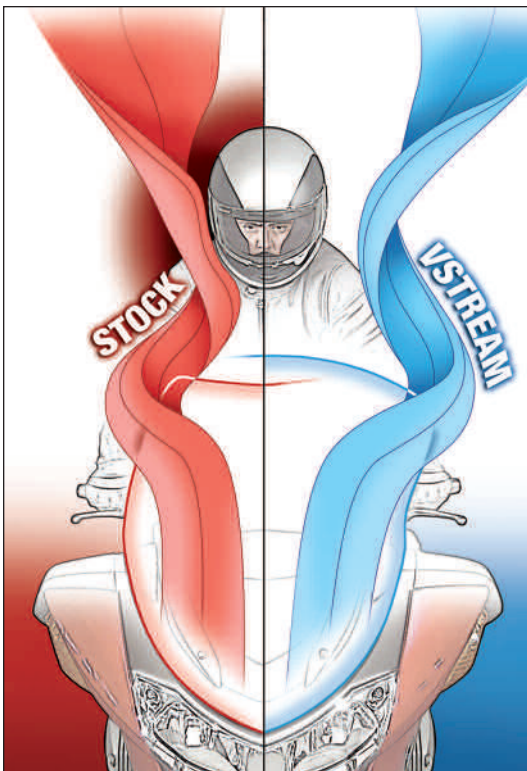

ZTechnik's innovative VStream® gets its name from the unique shape and dimensional contours designed and engineered into the windscreen.

The patented "V" profile helps push turbulent air out and away, producing a quieter and more comfortable riding experience for both the rider and the passenger.

VStream Windscreens

- Z2450** VStream Touring Windscreen
- Z2461** VStream Tall Touring Windscreen
- Z2462** VStream Sport Touring Windscreen

Fits 1998-10 K1200LT.

The Z2450 VStream does much more than effectively redirect wind; its quiet air pocket allows you to use your communication system with ease and, at the same time, stay warmer on those long late-season rides. Riders of the flagship K1200LT will want the ultimate touring screen – a VStream!

Riders that are taller or shorter than average will find comfort in VStream's alternative taller and shorter size windscreens for the K1200LT.

ZTechnik's exclusive 6.0mm thick Quantum® hardcoated polycarbonate gives you unbeatable scratch resistance with unmatched strength and durability.

All ZTechnik polycarbonate windscreens are backed by an exclusive 3-Year Warranty against breakage.

Specifications and Materials

	Z2450	Z2461	Z2462
	H: 22.70" (57.6cm) W: 28.10" (71.4cm) Color: Clear	H: 24.70" (62.8cm) W: 29.00" (73.6cm) Color: Clear	H: 20.70" (52.6cm) W: 27.00" (68.6cm) Color: Clear

6.0mm Polycarbonate with Quantum Hardcoating; ZTechnik 3-Year Warranty Against Breakage; Uses Existing Hardware; DOT/ABE Approved

VStream® Windscreens for 1992-97 K1100LT



WINDSCREENS
AND ACCESSORIES

K SERIES LT



VStream Windscreens

Z2454 VStream Touring Windscreen

Z2455 VStream Sport Touring Windscreen

Fits 1992-97 K1100LT, 1989-95 K75RT.

Riders of the classic K1100LT and K75RT can now enjoy VStream's famous comfort, performance and durability. VStream offers an improved and upgraded riding experience for older bikes that's too good to pass by.

The Z2454 is 2.00" taller and 3.00" wider than OEM screen, while the Z2455 is the stock height but 2.00" wider than OEM screen.

ZTechnik's exclusive Quantum® hardcoated polycarbonate gives you unbeatable scratch resistance with unmatched strength and durability.

All ZTechnik polycarbonate windscreens are backed by an exclusive 3-Year Warranty against breakage.



Carefully sculpted contours insure maximum windscreen stiffness as well as superior VStream performance.

Specifications and Materials

	Z2454	Z2455
H:	16.10" (40.9cm)	14.10" (35.8cm)
W:	25.00" (63.5cm)	23.75" (60.3cm)
Color:	Clear	Clear



4.5mm Polycarbonate with Quantum Hardcoating;
ZTechnik 3-Year Warranty Against Breakage;
Uses Existing Hardware; DOT/ABE Approved



Sport Touring Screens for 2001-05 K1200RS/GT

WINDSCREENS
AND ACCESSORIES

K SERIES RS/GT

Z2213



Z2214



Z2215



Stock rake adjustment is maintained with ZTechnik Replacement Screens, and the wind management is greatly improved. And, of course, they look great!

Sport Touring Windscreens

Z2213 Tall Touring Windscreen

Z2214 Sport Touring Windscreen

Z2215 Sport Touring Windscreen

Fits 2001-04 K1200RS and 2003-05 K1200GT.

The ZTechnik Z2213 is the ultimate windscreen for long distance touring on your 2001-04 K1200RS or 2003-05 K1200GT. Tough Lexan® polycarbonate construction means excellent impact resistance and superb optics. Try one on for size!

The Dark Tint Z2214 screen adds a lean, mean appearance to an already aggressively styled sport/touring bike, and is slightly smaller than the stock RS screen.

The Z2215 is similar to the Z2214, but in light tint polycarbonate, and a tad taller. It adds a crisp, clean and clear look to the 2001-04 K1200RS and 2003-05 K1200GT.

All ZTechnik polycarbonate windscreens are backed by an exclusive 3-Year Warranty against breakage.

Specifications and Materials

	Z2213	Z2214	Z2215
	H: 21.00" (53.3cm)	H: 13.00" (33.0cm)	H: 13.50" (34.3cm)
	W: Stock Width	W: Stock Width	W: Stock Width
	Color: Light Tint	Color: Dark Tint	Color: Light Tint

    **4.0mm Polycarbonate with FMR Hardcoating; ZTechnik 3-Year Warranty Against Breakage; Uses Existing Hardware; DOT/ABE Approved**

Sport Touring Screens for 1997-00 K1200RS



WINDSCREENS
AND ACCESSORIES

K SERIES RS

Z2211



Sport Touring Windscreens

Z2211 Tall Touring Windscreen

Z2212 Sport Touring Windscreen

Fits 1997-00 K1200RS.

Change your 1997-00 K1200RS to suit the season or your riding style. The tall, light tint Z2211, with 5.25" in height over the stock OEM windscreen, is perfect for cooler weather or longer rides.

The short, dark tint Z2212 is perfect for canyon carving and high velocity sprints. Get one of each!

Both of these ZTechnik polycarbonate windscreens are backed by an exclusive 3-Year Warranty against breakage.

Z2212



Stock rake adjustment is maintained with ZTechnik Replacement Screens, and the wind management is greatly improved. And, of course, they look great!

Specifications and Materials



Z2211
H: 20.25" (51.4cm)
W: 15.25" (38.7cm)
Color: Light Tint



Z2212
H: 14.00" (35.5cm)
W: 13.25" (33.6cm)
Color: Dark Tint



4.0mm Polycarbonate with FMR Hardcoating;
ZTechnik 3-Year Warranty Against Breakage;
Uses Existing Hardware; DOT/ABE Approved



Sport Touring Screens for K1200/1300R/S

WINDSCREENS
AND ACCESSORIES

K SERIES R/S

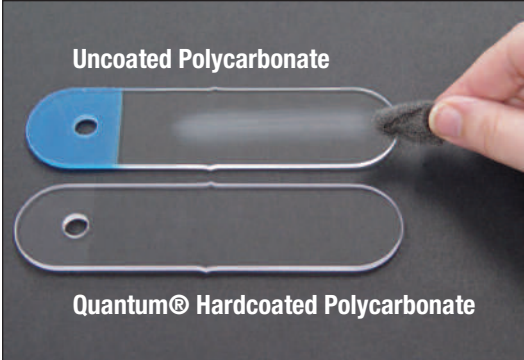

The uncoated OEM windscreen on the K1200S/K1300S will scratch very easily, but ZTechnik's Quantum® hardcoated polycarbonate screen will stand up to years of road riding abuse.

Quantum is 10X more scratch resistant than FMR coating, 30X more scratch resistant than typical acrylic, and WAY more scratch resistant than an uncoated screen!

Which screen should go on your K1200S or K1300S?

YOU choose!

Sport Touring Windscreens

Z2220 Sport Windscreen

Fits 2005-08 K1200S and 2009-15 K1300S.

What separates ZTechnik's K-S windscreen from the others is the world's toughest motorcycle windscreen material: Lexan® polycarbonate for unbeatable impact resistance along with Quantum® hardcoating for unmatched scratch resistance.

The Z2220 replaces the factory original screen using the same mounting points and hardware. The Dark Tint adds a cleaner but more aggressive appearance.

Z2225 Sport Touring Windscreen

Fits 2005-08 K1200R and 2009-13 K1300R.

This generously sized screen really puts the "tour" in sport-touring. The Z2225 includes precision-made aluminum mounting brackets (KIT-Z2225, included) and all necessary hardware for a perfect fit. ZTechnik's exclusive Quantum® hardcoating means the world's best scratch resistance, and tough Lexan® polycarbonate construction gives you the best impact and crack resistance. How tough is that?

As a bonus, this screen really cleans up the front end appearance of your K-R. And like all ZTechnik polycarbonate windscreens, it's covered by an exclusive 3-Year Warranty against breakage.

Specifications and Materials

Z2220	Z2225
H: Stock Height	H: 16.00" (40.6cm)
W: Stock Width	W: 20.50" (52.0cm)
Color: Dark Tint	Color: Dark Tint

4.5mm Polycarbonate with Quantum Hardcoating; ZTechnik 3-Year Warranty Against Breakage; Uses Existing Hardware; DOT/ABE Approved

VStream® Windscreens for 2008-16 F800GS/F650GS Twin



WINDSCREENS
AND ACCESSORIES

F SERIES GS

Z2490



Z2490



VStream Windscreens

Z2490 VStream Sport Windscreen

Fits 2008-16 F800GS, 2008-12 F650GS Twin.

Add an aggressive, sporty appearance to your new F800GS and F650GS Twin with this compact VStream sport screen. It features a strong, rigid lower contour that uses the headlight as an additional mount point while retaining complete headlight adjustability.

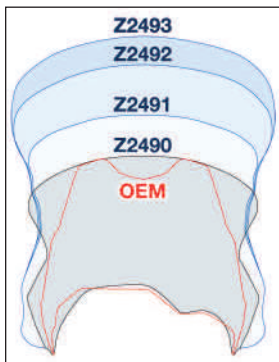

Full side-to-side steering lock is maintained as well. The Dark Tint really accents the bike's black bodywork.

Like all ZTechnik polycarbonate windscreens, they're covered by an exclusive 3-Year Warranty against breakage.

NOTE: Z5301 Mirror Extenders are required to mount these windscreens on the 2008-16 F800GS and 2008-12 F650GS Twin.



The Z2490 maintains full side-to-side steering lock.



The unique, well-designed contours of this VStream Windscreen reduce wind turbulence and buffeting.

Specifications and Materials



Z2490
H: 12.00" (30.5cm)
W: 13.25" (33.6cm)
Color: Dark Tint



4.5mm Polycarbonate with FMR Hardcoating;
ZTechnik 3-Year Warranty Against Breakage;
Hardware Included; DOT Approved, ABE Pending



VStream® Windscreens for 2008-16 F800GS/F650GS Twin

Z2491

Z2492

Z2493



WINDSCREENS
AND ACCESSORIES

F SERIES GS



The lower contours add strength and rigidity.



These VStream Windscreens use the headlight as an additional mounting point while maintaining complete headlight adjustability.

VStream Windscreens

Z2491 VStream Touring Windscreen

Z2492 VStream Tall Touring Windscreen

Z2493 VStream Extra Tall Touring Windscreen

Fits 2008-16 F800GS, 2008-12 F650GS Twin.

These touring versions of the F800GS and F650GS VStream Windscreens come in three different heights to fit riders of any size. All are made from rugged 4.5mm polycarbonate with FMR hardcoating. And, they offer more features for better value:

- Special 8-point mounting system uses headlight mounts but retains complete headlight adjustability.
- Windscreen contours reduce turbulence and buffeting, while the lower contour design adds strength/rigidity.
- Precision cut with smooth radiused edges and crystal clear optics. Full steering lock is maintained.

Like all ZTechnik polycarbonate windscreens, they're covered by an exclusive 3-Year Warranty against breakage.

NOTE: Z5301 Mirror Extenders are required to mount these windscreens on the 2008-16 F800GS and 2008-12 F650GS Twin.

Specifications and Materials



Z2491

H: 14.63" (37.1cm)

W: 14.00" (35.5cm)

Color: Clear

Z2492

H: 17.75" (45.1cm)

W: 15.75" (40.0cm)

Color: Clear

Z2493

H: 19.50" (49.5cm)

W: 16.00" (40.6cm)

Color: Clear



4.5mm Polycarbonate with FMR Hardcoating;
ZTechnik 3-Year Warranty Against Breakage;
Hardware Included; DOT Approved, ABE Pending

VStream+® Windscreens for 2013-16 F700GS



WINDSCREENS
AND ACCESSORIES

F SERIES GS



VStream Windscreens

Z2473 VStream Sport Windscreen

Z2479 VStream Sport Windscreen

Fits 2013-16 F700GS.

F700GS owners looking for a smaller shield for warm weather riding will appreciate ZTechnik's Z2473 Dark Tint and Z2479 Clear Sport Windscreens. These windscreens are considerably taller than the stock screen and are shaped in the VStream contour like our larger touring screens, Z2474 and Z2475 (featured on the next page) but does not include the side deflectors. The Sport Windscreen quickly mounts to the motorcycle in the stock location.

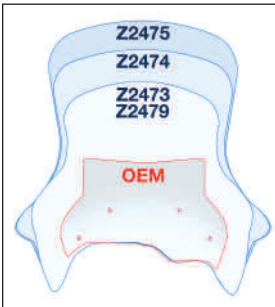

All ZTechnik polycarbonate windscreens are backed by an exclusive 3-Year Warranty against breakage.



Shorter F700GS riders will appreciate the Z2473 and Z2479 Sport Windscreen. This screen has the VStream contour of the larger touring screens, but does not include the side deflectors. It utilizes the stock mounting points.

Specifications and Materials

	Z2473 H: 13.75" (34.9cm) W: 12.25" (31.1cm) Color: Dark Tint	Z2479 H: 13.75" (34.9cm) W: 12.25" (31.1cm) Color: Clear
--	--	--



4.5mm Polycarbonate with FMR Hardcoating;
ZTechnik 3-Year Warranty Against Breakage;
Hardware Included; DOT Approved, ABE Pending



VStream+® Windscreens for 2013-16 F700GS

WINDSCREENS
AND ACCESSORIES

F SERIES GS

Side Deflectors
Detail



Z2475



The structural side deflectors not only support a taller, touring-sized windscreen, they also help reduce updrafts.

VStream Windscreens

Z2474 VStream Touring Windscreen

Z2475 VStream Tall Touring Windscreen

Fits 2013-16 F700GS.

Realizing that the small mounting area of the stock screen would not support a touring-size windscreen, ZTechnik's engineers solved the problem with a three-piece windscreen design. This brilliant solution adds windscreen side deflectors as structural mounts, giving this windscreen eight solid mounting points instead of the original four.

The result is phenomenal – a stable windscreen on the highway with the best wind management offered on a BMW GS twin. A pocket of calm air for the rider's torso is created by the structural side deflectors, and the patented VStream design reduces helmet buffeting to a minimum.

All ZTechnik polycarbonate windscreens are backed by an exclusive 3-Year Warranty against breakage.

Specifications and Materials

	Z2474	Z2475
	H: 16.75" (42.5cm) W: 15.50" (39.4cm) Color: Clear	H: 19.75" (50.0cm) W: 15.75" (40.0cm) Color: Clear



4.5mm Polycarbonate with FMR Hardcoating;
ZTechnik 3-Year Warranty Against Breakage;
Hardware Included; DOT Approved, ABE Pending

VStream® Windscreens for 2005-07 F650GS/F650GS Dakar



WINDSCREENS
AND ACCESSORIES

F SERIES GS



Z2411



Z2412



Z2413

VStream Windscreens

- Z2411** VStream Sport Windscreen
- Z2412** VStream Sport Touring Windscreen
- Z2413** VStream Touring Windscreen

Fits 2005-07 F650GS and F650GS Dakar.

VStream comfort, performance and durability are now available for the F650GS rider! Compared to the OEM windscreen, the Z2411 measures 2.00" taller, the Z2412 measures 2.80" taller and 1.00" wider, and the Z2413 measures 5.00" taller and 4.50" wider. That's a big improvement!

These ZTechnik VStream windscreens use the bike's existing windscreen mount points, and are compatible with the OEM handguards.

Made from 4.5mm thick Quantum® hardcoated polycarbonate for unbeatable scratch resistance with unmatched strength and durability.

Like all ZTechnik polycarbonate windscreens, they're covered by an exclusive 3-Year Warranty against breakage.

NOTE: Z5302 Mirror Extenders are required to mount the Z2413 windscreen to this model.



Z2413

OEM Accessory
Touring Screen

Compared to the OEM accessory touring windscreen, the ZTechnik Z2413 offers significantly more coverage and wind protection, and will be a superior performer on long tours and in cold weather.

Specifications and Materials

	Z2411	Z2412	Z2413
	H: 12.30" (31.2cm) W: 11.30" (28.7cm) Color: Light Tint	H: 15.30" (38.9cm) W: 13.00" (33.0cm) Color: Clear	H: 19.30" (49.0cm) W: 16.50" (41.9cm) Color: Clear



4.5mm Polycarbonate with Quantum Hardcoating;
ZTechnik 3-Year Warranty Against Breakage;
Hardware Included; DOT/ABE Approved



Sport Touring Screens for 2001-03 F650CS/GS Dakar

WINDSCREENS
AND ACCESSORIES

F SERIES GS



The Z2261 for the 2001-03 F650CS offers a big improvement in wind protection compared to the OEM windscreen.

Sport Touring Windscreens

Z2261 Sport Touring Windscreen

Fits 2001-03 F650CS.

The Z2261 is taller than the OEM screen, with a more upright angle and innovative shape for smooth airflow and reduced wind noise and "buffeting." The Z2261 mounts in minutes using existing mounting hardware.

Z2263 Touring Windscreen

Z2264 Tall Touring Windscreen

Fits 2001-03 F650GS Dakar.

This shield features a more upright angle and an innovative shape, resulting in a noticeable reduction in wind noise and buffeting.

The Z2263 is 16.00" tall, while the Z2264 adds an extra 2.00" for taller riders or those wanting extra wind protection.

Both screens fit the 2001-03 F650GS Dakar, and they also fit the 2001-03 F650GS when used with BMW part #71-60-7-653-849.

Like all ZTechnik polycarbonate windscreens, they're covered by an exclusive 3-Year Warranty against breakage.

Specifications and Materials



Z2261

H: 17.25" (43.8cm)
W: Stock Width
Color: Light Tint



Z2263/Z2264

H: Z2263: 16.00" (40.6cm)
Z2264: 18.00" (45.7cm)
W: 15.50" (39.4cm)
Color: Light Tint



4.0-4.5mm Polycarbonate with FMR Hardcoating;
ZTechnik 3-Year Warranty Against Breakage;
Uses Existing Hardware; DOT/ABE Approved

VStream+® Windscreens for 2010-13 F800R



WINDSCREENS
AND ACCESSORIES

F SERIES R



VStream Windscreens

- Z2428** VStream Sport Windscreen
- Z2424** VStream Sport Touring Windscreen
- Z2425** VStream Sport Touring Windscreen
- Z2426** VStream Touring Windscreen

Fits 2010-13 F800R.

ZTechnik® brings VStream® Windscreen performance to the F800R! The Z2424/Z2425 gives the front end a sporty fairing-style appearance while deflecting the high speed wind blast away from the upper body for riders 5'8" (172cm) or shorter.

The touring size Z2426 deflects the wind blast at high speeds away from the upper body for riders up to 5'10" (178cm) tall.

Sport riders will find the perfect screen on the ultra sporty Z2428.

Tough 4.5mm FMR coated polycarbonate gives these VStream windcreens outstanding clarity and strength characteristics unmatched by any windscreen maker worldwide. They are 3X more resistant to abrasion than acrylic materials, and have 20X greater crack and impact resistance.

Covered by ZTechnik's 3-Year Warranty against breakage!

Specifications and Materials

	Z2428	Z2424/Z2425	Z2426
	H: 12.13" (30.8cm) W: 16.10" (40.9cm) Color: Dark Tint	H: 16.00" (40.7cm) W: 15.00" (38.1cm) Color: Clear/Dark Tint	H: 19.00" (48.3cm) W: 17.00" (43.2cm) Color: Clear

4.5mm Polycarbonate with FMR Hardcoating;
ZTechnik 3-Year Warranty Against Breakage;
Uses Existing Hardware; DOT Approved, ABE Pending



Impossible clearances are made possible... by ZTechnik!

Strong, 3-gauge (.25"/.6cm) compact laser-cut brackets are cleverly designed to clear all the bike's cables and hoses, and are easy to install without removing any of the bike's stock parts – something only ZTechnik could accomplish!

Sturdy 6-point windscreen mounting provides stability and rigidity when riding.

Heavy rubber grommets absorb vibrations.



VStream® Windscreens for 2013-16 F800GT

WINDSCREENS
AND ACCESSORIES

F SERIES GT



Z2478

VStream Windscreens

- Z2476** VStream Sport Windscreen
- Z2477** VStream Sport Touring Windscreen
- Z2478** VStream Touring Windscreen

Fits 2013-16 F800GT.

The tractable motor, great luggage options, and light weight make the F800GT an ideal sport touring bike, but the wind protection needed improvement. ZTechnik's engineers designed a range of VStream windscreens using the stock mounting hardware along with additional mounting hardware to ensure secure attachment.

Three different sizes are available to fit a variety of riders, all of them featuring the patented VStream design. This aeroacoustic design helps push wind to the side and reduces helmet buffeting to a minimum, resulting in a quiet, more comfortable ride.

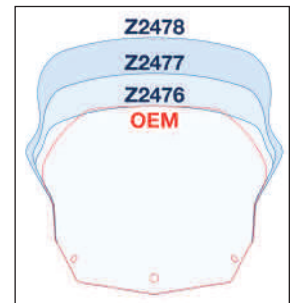

Specifications and Materials

	Z2476	Z2477	Z2478
	H: 15.00" (38.1cm) W: 16.50" (41.9cm) Color: Dark Tint	H: 21.00" (53.3cm) W: 17.25" (43.8cm) Color: Light Tint	H: 24.25" (61.6cm) W: 18.00" (45.7cm) Color: Clear



ZTechnik's Quantum® hard-coated polycarbonate gives these windscreens superior optical clarity and unbeatable scratch resistance. Nothing else even comes close!



4.5mm Polycarbonate with Quantum Hardcoating;
ZTechnik 3-Year Warranty Against Breakage;
Hardware Included; DOT/ABE Approved

VStream® Windscreens for 2006-12 F800S/F800ST



WINDSCREENS
AND ACCESSORIES

F SERIES S/ST

Z2430



VStream Windscreens

Z2430 VStream Sport Touring Windscreen

Z2431 VStream Touring Windscreen

Fits 2006-11 F800S, 2006-12 F800ST.

The Z2430 VStream adds more wind protection and a quieter ride to the sporty F800S and F800ST. Its FMR coated polycarbonate is 20X more impact resistant than acrylic (aircraft plastic) windscreen.

The Z2431 is a taller version of the Z2430 for even greater wind protection. This is a screen you'll really appreciate for long distance touring or riding in cold weather.

Both of these ZTechnik polycarbonate windscreens are backed by an exclusive 3-Year Warranty against breakage.

Z2430



Z2431



Specifications and Materials



Z2430
H: 16.50" (41.9cm)
W: 16.00" (40.6cm)
Color: Clear



Z2431
H: 19.00" (48.2cm)
W: 17.00" (43.2cm)
Color: Clear



4.5mm Polycarbonate with FMR Hardcoating;
ZTechnik 3-Year Warranty Against Breakage;
Hardware Included; DOT/ABE Approved

Both the Z2430 and the taller Z2431 fit either the F800S or the F800ST. Get both for all-season versatility.



VStream® Windscreens for 2009-10 G650GS Single

WINDSCREENS
AND ACCESSORIES

G SERIES GS



Z2411



Z2412



Z2413

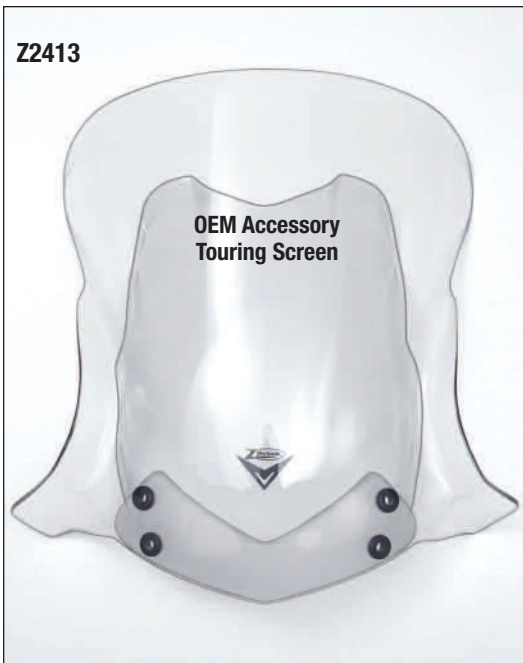

Z2413

OEM Accessory
Touring Screen

Compared to the OEM accessory touring windscreen, the ZTechnik Z2413 offers significantly more coverage and wind protection, and will be a superior performer on long tours and in cold weather.

VStream Windscreens

- Z2411 VStream Sport Windscreen
- Z2412 VStream Sport Touring Windscreen
- Z2413 VStream Touring Windscreen

Fits 2009-10 G650GS.

VStream comfort, performance and durability are now available for the G650GS rider! Compared to the OEM windscreen, the Z2411 measures 2.00" taller, the Z2412 measures 2.80" taller and 1.00" wider, and the Z2413 measures 5.00" taller and 4.50" wider. That's a big improvement!

These ZTechnik VStream windscreens use the bike's existing windscreen mount points, and are compatible with the OEM handguards.

Made from 4.5mm thick Quantum® hardcoated polycarbonate for unbeatable scratch resistance with unmatched strength and durability.

Like all ZTechnik polycarbonate windscreens, they're covered by an exclusive 3-Year Warranty against breakage.

NOTE: Z5302 Mirror Extenders are required to mount the Z2413 windscreen to this model.

Specifications and Materials

	Z2411	Z2412	Z2413
	H: 12.30" (31.2cm) W: 11.30" (28.7cm) Color: Light Tint	H: 15.30" (38.9cm) W: 13.00" (33.0cm) Color: Clear	H: 19.30" (49.0cm) W: 16.50" (41.9cm) Color: Clear

4.5mm Polycarbonate with Quantum Hardcoating;
 ZTechnik 3-Year Warranty Against Breakage;
 Hardware Included; DOT/ABE Approved

VStream+® Windscreens for 2011-16 G650GS/Sertão



WINDSCREENS
AND ACCESSORIES

G SERIES GS

Z2470



VStream Windscreens

Z2470 VStream Sport Windscreen

Fits 2011-16 G650GS, 2012-15 G650GS Sertão.

ZTechnik has developed three VStream® windscreens for the 2011-16 BMW G650GS and 2012-15 G650GS Sertão.

The additional wind protection provided by the VStream required a stronger mounting system than the OEM bracket. Many oversize aftermarket windscreens mount on the OEM bracket, leading to vibration of the windshield.

ZTechnik designed and manufactured a structural tubular frame that ensures stability of the windscreen at all speeds. The tubular frame mounts to four solid points at the sides of the headlight housing.

It is easy to assemble and offers an additional mounting point for ZTechnik's Accessory Mounts.

Z2470



The low, sporty height of the Z2470 is accented by its rich, dark tinted color.

Specifications and Materials

Z2470

H: 11.00" (28.0cm)

W: 13.00" (33.0cm)

Color: Dark Tint



4.5mm Polycarbonate with FMR Hardcoating;
ZTechnik 3-Year Warranty Against Breakage;
Hardware Included; DOT/ABE Approved

Z2471

Z2472



The strong tubular steel bracket offers a solid four point mounting for increased stability of larger windscreens ridden at highway speeds. Now the G650GS can be a viable touring bike as well as an off-road explorer.

VStream Windscreens

Z2471 VStream Sport Touring Windscreen

Z2472 VStream Touring Windscreen

Fits 2011-16 G650GS, 2012-15 G650GS Sertão.

These VStream® windscreens are available in three different heights and tints and are made from tough 4.5mm FMR hardcoated polycarbonate. This high quality material, along with state-of-the-art manufacturing techniques, gives these windscreens outstanding clarity and strength characteristics unmatched by any windscreen maker worldwide.

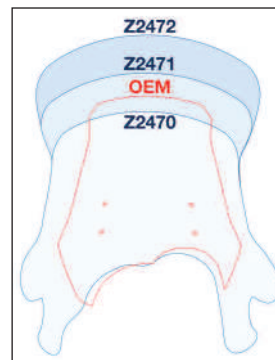

They are 30X more scratch resistant and have 20X greater crack and impact resistance than other aftermarket windscreens on the market made from commonly used acrylic or "aircraft plastic".

Like all ZTechnik polycarbonate windscreens, they are backed by an exclusive 3-Year Warranty against breakage.

Specifications and Materials

	Z2471	Z2472
	H: 14.00" (35.5cm) W: 14.75" (37.4cm) Color: Light Tint	H: 17.00" (43.2cm) W: 15.75" (40.0cm) Color: Clear

4.5mm Polycarbonate with FMR Hardcoating; ZTechnik 3-Year Warranty Against Breakage; Hardware Included; DOT/ABE Approved

Heavy Duty™ Windshields for 1996-05 R850/1200C



WINDSCREENS
AND ACCESSORIES

R SERIES C



Heavy Duty Cruiser Windshields

- N2220** Custom Heavy Duty Windshield
- N2221** Low Boy Heavy Duty Windshield
- KIT-BI** Heavy Duty Mount Kit

Fits 2000-03 R850/1200C Avantgarde, 1996-05 R850/1200C Classic, 1998-02 R850/1200C Euro, 2000-03 R1200C Montana, 2000-03 R1200C Stiletto.

The Custom Heavy Duty and Low Boy Heavy Duty Windshields offer excellent wind protection, the perfect classic look, and the toughest windshield material available: Quantum® hardcoated Lexan® polycarbonate, exclusively from ZTechnik by National Cycle, Inc.

The required KIT-BI Mount Kit is made from triple chrome plated steel and offers easy installation/removal. The KIT-BI Mount Kit is sold separately.

All ZTechnik polycarbonate windscreens are backed by an exclusive 3-Year Warranty against breakage.



Think about riding into the sun's glare, or riding at night into on-coming headlights, without having to strain to see through the reflected haze from fine scratches and abrasions on your windshield (above left). This is not the optimal view of the road ahead for ANY rider.

ZTechnik's exclusive Quantum® hardcoating gives your windshield much better optical definition and clarity by preventing and reducing the buildup of scratches and abrasions.

Quantum delivers 30X more scratch resistance than typical acrylic material, and even 10X more than the standard FMR hardcoated polycarbonate!

With Quantum hardcoating, your windshield will be clearer and will stay that way a lot longer. That's the kind of performance and strength you need in a motorcycle windshield.

Specifications and Materials

	N2220 H: 19.00-21.00" (48.2-53.3cm) W: 19.00" (48.3cm) Color: Clear	N2221 H: 14.25-16.00" (36.2-40.6cm) W: 18.75" (47.6cm) Color: Clear
--	---	---



**4.0mm Polycarbonate with Quantum Hardcoating;
ZTechnik 3-Year Warranty Against Breakage;
Mount Kit Sold Separately; DOT/ABE Approved**



Tall Touring Windscreen for 2003-05 R1200CL/CLC

WINDSCREENS
AND ACCESSORIES

R SERIES CL

Z2271



When you watch our online video demonstration, you'll see why we manufacture our windscreens from thick Lexan® polycarbonate material. There is simply nothing else that stands up to its strength and durability. Compared to standard acrylic windscreens, polycarbonate is 20X more impact resistant and 23X more crack resistant. That's performance you can feel comfortable and secure riding behind!

All ZTechnik windscreens are Quantum® or FMR hardcoated to give you superior scratch resistance. The type of hardcoat applied will depend on the size and design of windscreen.

For Quality, Value and Price, whether FMR or Quantum hardcoated, your polycarbonate windscreen from ZTechnik will outperform any other windscreen available.

Cruiser Windscreens

Z2271 Tall Touring Windscreen

Fits 2003-05 R1200CL/CLC.

Built with durable 4.5mm Lexan® polycarbonate. Each windscreen is individually cut, edge contoured, and formed for superior optics and great looks.

The Z2271 is 9.00" taller than stock for increased wind protection. If you plan any long tours with your CL, this is the shield that will want.

Like all ZTechnik polycarbonate windscreens, it's covered by an exclusive 3-Year Warranty against breakage.

Specifications and Materials



Z2271
H: 17.00" (43.2cm)
W: Stock Width
Color: Light Tint



4.5mm Polycarbonate with FMR Hardcoating;
ZTechnik 3-Year Warranty Against Breakage;
Uses Existing Hardware; DOT Approved, ABE Pending

VStream® Windscreens for 2013-16 G650GT



WINDSCREENS
AND ACCESSORIES

C SERIES GT



VStream Windscreens

- Z2494** VStream Sport Windscreen
- Z2495** VStream Sport Touring Windscreen
- Z2496** VStream Touring Windscreen

Fits 2013-16 C650GT.

With its powerful motor, full fairing, and ample cargo capacity, the C650GT is at home on a freeway as well as in the city. Now many C650GT riders are using this urban mobility vehicle as a touring bike, and are looking for highway accessories.

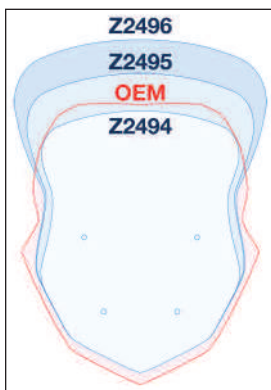

ZTechnik's engineers designed a range of VStream windscreens for the C650GT. They install with the stock mounting hardware, retain full height adjustability, and allow for use of the OEM two-position wind deflectors mounted below the windscreen as well.

Three different sizes are available to fit a variety of riders, all featuring the patented VStream design.

Like all ZTechnik polycarbonate windscreens, they're covered by an exclusive 3-Year Warranty against breakage.



Specifications and Materials

Z2494	Z2495	Z2496
H: 23.00" (58.4cm)	H: 26.50" (67.3cm)	H: 29.75" (75.5cm)
W: 17.25" (43.8cm)	W: 20.00" (50.8cm)	W: 22.00" (55.9cm)
Color: Dark Tint	Color: Clear/Dark Tint	Color: Clear

Designed to be narrow enough to allow lock-to-lock handlebar movement, the VStream is wider at the top to push the wind vortex to the side to ensure a calm pocket of air for the rider and passenger. This reduces helmet buffeting to a minimum.



4.5mm Polycarbonate with FMR Hardcoating;
ZTechnik 3-Year Warranty Against Breakage;
Uses Existing Hardware; DOT Approved, ABE Pending



Windscreen Accessories

ZTechnik Mirror Extenders



Z5300



Z5302



Z5301

The Z5301 Mirror Deflectors include drilled access points for the OEM handlebar control adjusting screws.



Z5303

The Z5303 Mirror Deflectors are made especially for the R1200GS Adventure's handlebar control mounts.

Windscreen Accessories

Z5300 Mirror Extenders; Pair

Fits 2004-12 R1200GS, 2006-14 R1200R, 2005-08 R1200ST.

Z5301 Mirror Extenders; Pair

Fits 2008-16 F800GS, 2013-16 F700GS, 2008-12 F650GS Twin.

Z5302 Mirror Extenders; Pair

Fits 2005-07 F650 GS/Dakar and 2009-10 G650GS

Z5303 Mirror Extenders; Pair

Fits 2006-13 R1200GS Adventure

Give yourself a better view of the road and the vehicles behind you!

The Z5300 and Z5301 Mirror Extenders move your bike's mirrors out an additional 2 inches (52mm) on each side. The Z5302 and Z5303 Mirror Extenders move your bike's mirrors out an additional 2.5 inches (64mm) on each side. Competitive extenders only add 1.5 inches (less than 35mm) on each side.

ZTechnik Mirror Extenders allow you to see more easily past your shoulders, your passenger and your gear. They also move the mirror stalks further out when using a wider than stock windscreen like a ZTechnik VStream®.

This is a great 5-minute do-it-yourself upgrade that you'll appreciate!

Specifications and Materials



Laser Cut 3-Gauge (.25-inch) Steel with Satin Black Finish;
All Hardware Included

WINDSCREENS
AND ACCESSORIES

MULTI-FIT

Windscreen Accessories ZTechnik Headlight Guards

NEW



WINDSCREENS
AND ACCESSORIES

R SERIES GS

Z5402



Windscreen Accessories

Z5401 Polycarbonate Headlight Guard

Fits 2013-16 R1200GS and 2014-16 R1200GS Adventure.

Z5402 Polycarbonate LED Headlight Guard

Fits 2013-16 R1200GS and 2014-16 R1200GS Adventure.

ZTechnik Headlight Guards perfectly match the contours of your bike's headlight. They're thermoformed to wrap around the headlight frame cover, where they are attached using marine-grade Velcro®. No Velcro on the headlight lens! Crystal clear optics will not distort or reduce the light beam. These Headlight Guards virtually disappear when installed!

Formed from tough 3mm polycarbonate with ZTechnik's exclusive Quantum® hardcoating for 10X more strength and 30X more scratch resistance than fragile acrylic guards. Protect your headlight with a hardcoated polycarbonate Headlight Guard from ZTechnik.

Just like ZTechnik's polycarbonate windscreens, they're covered by an exclusive 3-Year Warranty against breakage.

Why trust your expensive headlight assembly to anything less?

Z5401



The Velcro® mounting for our Headlight Guards is practically invisible when installed!

Uncoated Polycarbonate

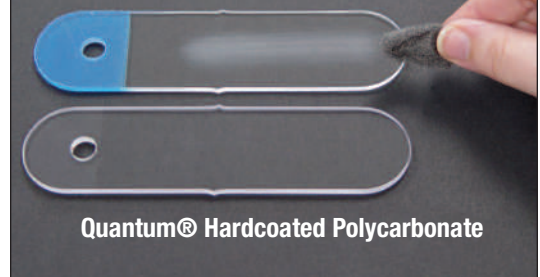

Quantum® Hardcoated Polycarbonate

Specifications and Materials



3.0mm Polycarbonate with Quantum Hardcoating;
ZTechnik 3-Year Warranty Against Breakage;
All Hardware Included; DOT Approved/ABE Pending

Quantum is 10X more scratch resistant than FMR coating and 30X more scratch resistant than typical acrylic.

Which would you rather have?



Windscreen Accessories

ZTechnik Headlight Guards

WINDSCREENS
AND ACCESSORIES

MULTI-FIT



Z5210



Z5400

The Velcro® mounting for our Headlight Guards is practically invisible when installed!

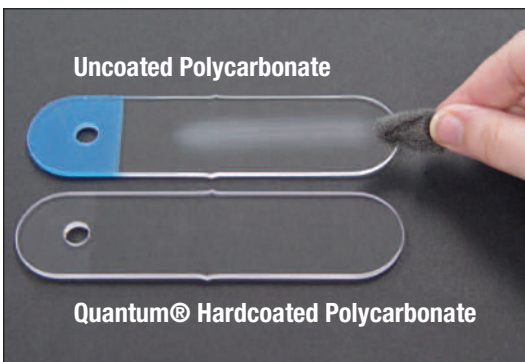

Quantum is 10X more scratch resistant than FMR coating and 30X more scratch resistant than typical acrylic.

Which would you rather have?

Windscreen Accessories

Z5400 Polycarbonate Headlight Guard

Fits 2004-13 R1200GS (Oilcooled) and 2006-13 R1200GS Adventure.

Z5410 Polycarbonate Headlight Guard

Fits 2008-14 F800GS, 2009-13 F800R, 2013-14 F700GS, 2008-12 F650GS Twin.

ZTechnik Headlight Guards perfectly match the contours of your bike's headlight. They're thermoformed to wrap around the headlight frame cover, where they are attached using marine-grade Velcro®. No Velcro on the headlight lens! Crystal clear optics will not distort or reduce the light beam. These Headlight Guards virtually disappear when installed!

Formed from tough 3mm polycarbonate with ZTechnik's exclusive Quantum® hardcoating for 10X more strength and 30X more scratch resistance than fragile acrylic guards. Protect your headlight with a hardcoated polycarbonate Headlight Guard from ZTechnik.

Just like ZTechnik's polycarbonate windscreens, they're covered by an exclusive 3-Year Warranty against breakage.

Why trust your expensive headlight assembly to anything less?

Specifications and Materials



Windscreen Accessories

Windscreen Stabilizer Kit

NEW



WINDSCREENS
AND ACCESSORIES

R SERIES GS

Z5220



Windscreen Accessories

Z5220 Windscreen Stabilizer Kit

Fits 2013-16 R1200GS and GS Adventure (Watercooled).

ZTechnik's Z5220 Windscreen Stabilizer Kit adds support, strength and stability to the OEM windscreen mount arms on 2013 and later BMW® R1200GS and GS Adventure motorcycles.

The Stabilizer Kit securely supports even the tallest ZTechnik Touring Deluxe Windscreen (Z2388; 22.00" Height). The Z5220 Kit also works with all OEM and aftermarket windscreens currently available.

The Stabilizer Kit installs easily and is fully compatible with the OEM windscreen height adjust hardware. Simply loosen the two Stabilizer knobs, adjust the windscreen like you normally do, re-tighten the two knobs, and off you go!



Specifications and Materials



Injection Molded Nylon Plastic with Powdercoated Steel Hardware; Supplement to Existing Parts; All Hardware Included

Height adjustments are easy to make with the addition of the Stabilizer Kit and riding will be much more enjoyable with windscreen vibration almost completely eliminated.



Windscreen Accessories

LeverAction™ Rake Adjust Kit

WINDSCREENS
AND ACCESSORIES

R SERIES GS

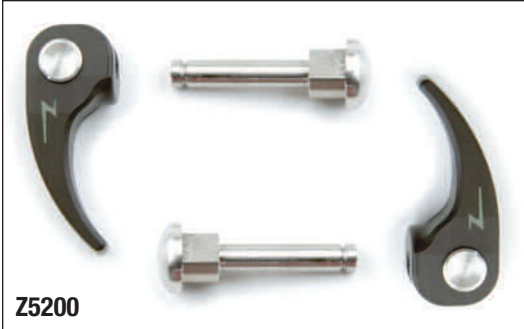

LeverAction works great with both BMW® and ZTechnik windcreens and is made of nylon plastic and stainless steel for long lasting durability and high-tech good looks.

Windscreen Accessories

Z5200 LeverAction™ Rake Adjust Kit

Fits 2004-13 R1200GS (Oilcooled).

Z5202 LeverAction™ Rake Adjust Kit

Fits 2006-13 R1200GS Adventure.

ZTechnik adds a new twist to a familiar design.

The windshield experts introduce LeverAction™, a trick replacement kit that obsoletes the knob-and-nut hardware on the R1200GS windscreen.

ZTechnik wants to enhance every mile you spend on your R1200GS/GSA by making your equipment work easier with enhanced functionality. To that end, ZTechnik developed LeverAction, a slick looking, injection molded lever that replaces the chunky rake adjustment knobs on the R1200GS/GSA.

LeverAction combines the shaft and nut of the traditional windscreen adjustment hardware into a one-piece design, eliminating the possibility of nuts getting loose and falling into your motorcycle. A quick flip of the lever is all it takes to disengage the windscreen – within seconds you will have your screen in its new position and be back on the road!

Specifications and Materials



Injection Molded Nylon Plastic with Stainless Steel Hardware; Direct Replacement for Existing Parts; All Hardware Included

Shield Wash™ Cleaner for All Windscreens/Faceshields



WINDSCREENS
AND ACCESSORIES

MULTI-FIT



Windscreen Accessories

N1401-01 Shield Wash Windscreen Cleaner

For All Motorcycle Windscreens and Faceshields.

We use our in-house chemical lab and Tantec™ Contact Angle Meter testing equipment to analyze how surface tension created by various plastic treatments, cleaners, and polishing products affect the surface of the windscreen and its ability to stay clean.

After extensive road testing and research, we hit on the right combination of cloth and chemical that will keep the rider's windscreen as clean as possible while on the road.

Our Shield Wash™ is made to create that low surface tension that is the key to keeping a windscreen clean. Just as important is the cloth. The cleaning cloth we use is soft, but it lifts and holds dirt. It provides just the right amount of absorbency as well.

National Cycle Shield Wash is designed to effectively clean virtually any optical part – windscreens, faceshields, sunglasses, etc. It is fully compatible with our exclusive Quantum® hardcoating, as well as GE's FMR hardcoating. It also works well on all High Impact Acrylic and standard acrylic surfaces.



Watch the online demonstration video and learn how to use National Cycle's Shield Wash™ and RainZip® on motorcycle windscreens, and then see an actual demonstration of how well it works!

Materials and Specifications

The Shield Wash cleaning kit includes an eight-ounce bottle of Shield Wash and a one-ounce refillable bottle with a small microfiber cloth to carry on the motorcycle. It's everything a rider needs to keep their windscreen sparkling clean!



RainZip® Rain Repellent for All Windscreens/Faceshields

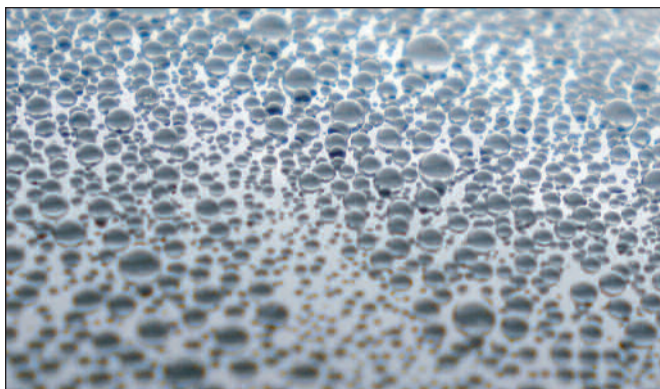

104°	Quantum Hardcoated Polycarbonate + RainZip
88°	Quantum Hardcoated Polycarbonate
78°	FMR Hardcoated Polycarbonate
59°	Acrylic



Watch the online demonstration video and learn how to use National Cycle's Shield Wash™ and RainZip® on motorcycle windcreens, and then see an actual demonstration of how well it works!



Windscreen Accessories

N1410-01 RainZip Rain Repellent Treatment

For All Motorcycle Windscreens and Faceshields.

To keep your windscreen clearer in rainy weather, National Cycle and ZTechnik developed RainZip®, a specially formulated rain repellent treatment that is safe to use on any Quantum® or FMR hardcoated Windscreen. And, it's safe to use on ANY motorcycle windscreen, as well as helmet faceshields and goggles.

RainZip is hydrophobic – when rain accumulates on the windscreen, RainZip causes it to effectively bead up and blow away, even at riding speeds of only 20-30MPH.

RainZip will give riders a clearer view of the road ahead... especially when it's wet!

Materials and Specifications

RainZip is available in a 3-oz. size with a special application cloth – enough for three applications. One application will last 3-4 months.

Genuine Carbon Fiber Fuel Cap Trim



Z8890



Z8891

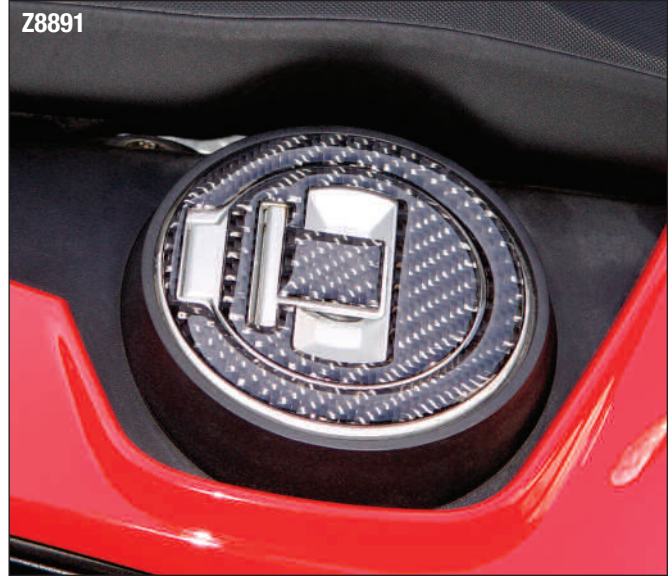

Genuine Carbon Fiber Trim

Z8890 Carbon Fiber Fuel Cap Trim

Fits a wide range of BMW models with exposed fuel trim ring torx fasteners. Protects filler area from key and fuel pump damage. ZTechnik carbon fiber is protected with a top coat that will not yellow. Secures with 3M® waterproof adhesive that is also fuel resistant.

Z8891 Carbon Fiber Fuel Cap Trim

Fits a range of BMW models with concealed fuel trim ring fasteners. Protects the fuel trim ring and cap from key and fuel pump damage.

Z8892 Carbon Fiber Fuel Cap Trim

Fits a range of later model BMW motorcycles with exposed fuel trim ring torx fasteners.

Z8892

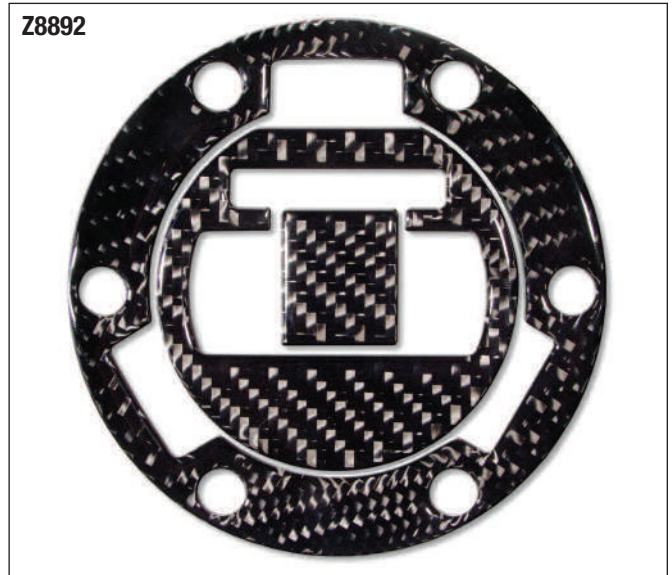

APPEARANCE
AND TRIM

MULTI-FUT

Poured Clear Resin Layer

Woven Carbon Fiber Layer

Pressure Sensitive Adhesive Layer



Laminate Construction of Genuine Carbon Fiber

High quality, genuine woven carbon fiber material is first cut to shape with a precision die.

Next, a clear resin is carefully applied so that the entire perimeter has a smooth, radiused edge, producing a fluid transition to the contact surface of the motorcycle at all points.

A pressure sensitive adhesive backing is applied that securely, but safely, attaches the carbon fiber piece to the motorcycle.



All ZTechnik Genuine Carbon Fiber accessories are designed on each individual motorcycle model. This guarantees a perfect and precise fit with contours and edges that compliment the design of the motorcycle's bodywork.

ZTechnik Genuine Carbon Fiber accessories are made to stand up to years of use. They will not delaminate like cheaper imitations, nor will they fade and bleach out like faux carbon fiber material.

Like all other ZTechnik Accessories for BMW® Motorcycles, they're made to the highest quality standards – our own.

Refer to the ZTechnik Application Guide for the latest fitment information and updates.



Genuine Carbon Fiber Tank Protectors



Z8500 Carbon Fiber Tank Protector

Fits a wide range of BMW models. Measures 7.50" (19.0cm) long. Genuine carbon fiber cloth is protected by a clear, smooth resin top coat that will not yellow. 3M® waterproof adhesive means no peeling like the lower cost protectors. Styled for the BMW rider.

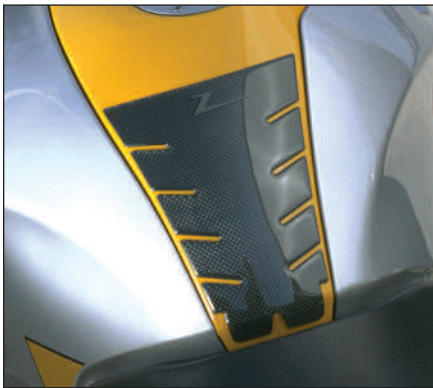

Z8501 Carbon Fiber Tank Protector

Fits a wide range of GS, R and S models. Measures 8.00" (20.3cm) long. Designed to be a perfect fit for the center section of your tank.



Z8502 Carbon Fiber Tank Protector

Fits all R1200RT and R1200R models. Compact size will not interfere with tank bag mounts on your R1200RT.



Z8503 Carbon Fiber Tank Protector

Fits all model years of R1200ST and R1200S, as well as the new K1600GT/GTL. Stylish design complements the bike's sleek lines.



Z8504 Carbon Fiber Tank Protector

Fits all model years of BMW's flagship sport bike, the K1200S and K1300S. Designed to fit the center section of the tank to prevent scratching from abrasive materials and zippers.



Z8505 Carbon Fiber Tank Protector

Fits a wide range of BMW models from G650GS to K1300GT.

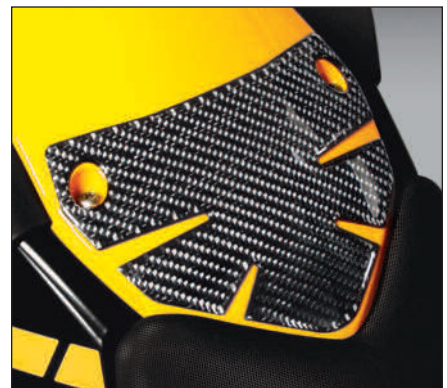

Z8506 Carbon Fiber Tank Protector

Fits all F800GS, F700GS and F650GS Twin. Aggressive design also allows for easy removal of the tank's center section for charging the battery and other maintenance.

APPEARANCE
AND TRIM

MULTI-FIT

Refer to the ZTechnik Application Guide for the latest fitment information and updates.

Genuine Carbon Fiber Gauge Panel, Luggage Rack Trim



Z8602



Z8602 Carbon Fiber Gauge Panel Trim

Fits 1994-04 R1100/1150RT.

The 2-piece Z8602 is a specialty fit for these early touring models.

Z8611



Z8611 Carbon Fiber Gauge Panel Trim

Fits 2006-08 K1200GT.

The Z8611 Gauge Panel Trim is a specialty fit for this sport-touring model.

APPEARANCE
AND TRIM

Z8640

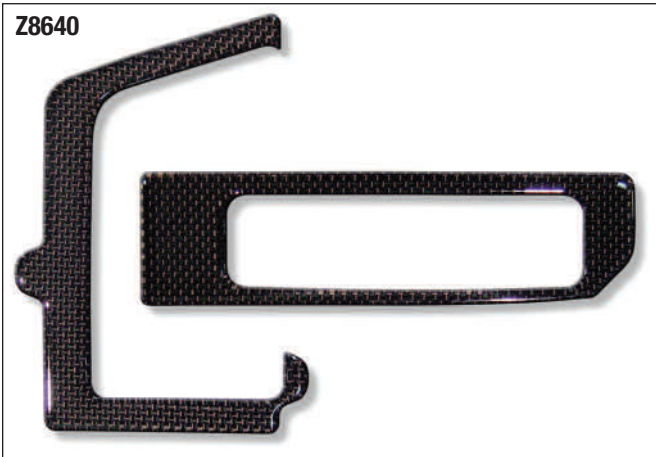

Z8640 Carbon Fiber Gauge Panel Trim

Fits 1999-03 R1150GS, 1996-01 R850GS.

The 2-piece Z8602 Gauge Panel Trim fits these early GS models.

Z8901

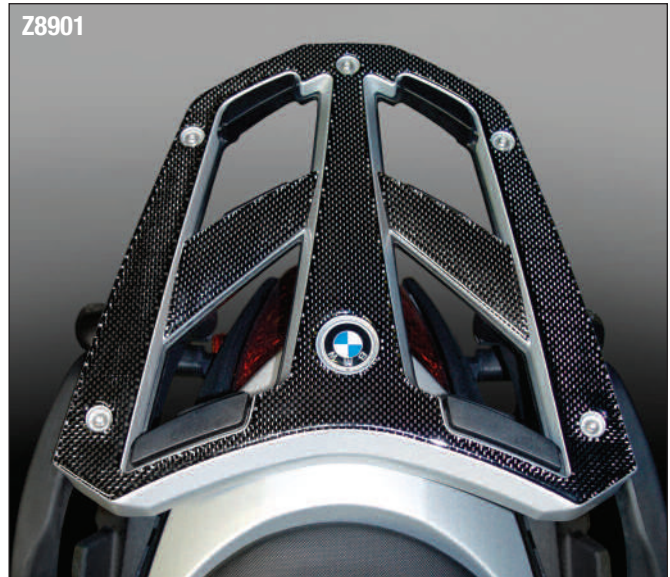

Z8901 Carbon Fiber Luggage Rack Trim

Fits 2006-10 R1200R.

Save wear and tear on your powdercoated luggage rack with our Carbon Fiber Luggage Rack Trim. The Z8901 fits perfectly and exactly on the 2006-10 R1200R.

MULTI-FIT

Laminate Construction of Genuine Carbon Fiber

High quality, genuine woven carbon fiber material is first cut to shape with a precision die.

Next, a clear resin is carefully applied so that the entire perimeter has a smooth, radiused edge, producing a fluid transition to the contact surface of the motorcycle at all points.

A pressure sensitive adhesive backing is applied that securely, but safely, attaches the carbon fiber piece to the motorcycle.

Poured Clear Resin Layer

Woven Carbon Fiber Layer

Pressure Sensitive Adhesive Layer





Genuine Carbon Fiber Carbon Fiber Trim Sets

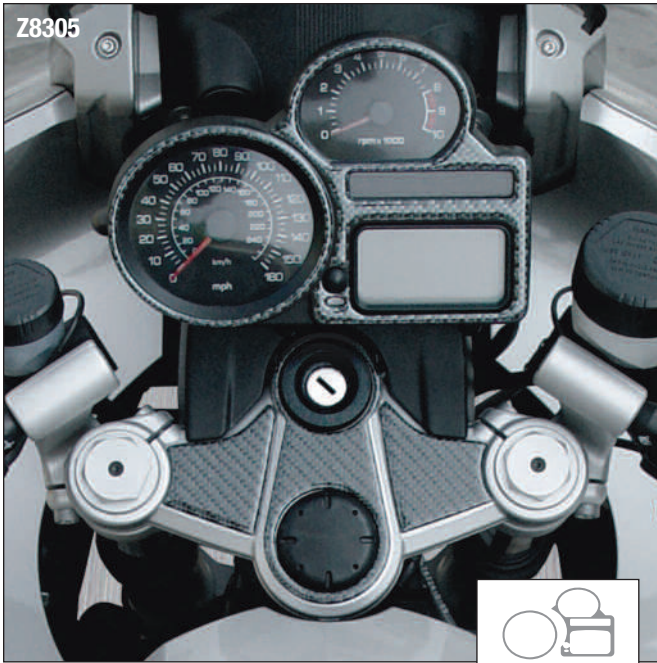

Z8305

Genuine Carbon Fiber Trim

Z8305 Carbon Fiber Trim Set

Fits 2005-08 R1200ST.

The Z8305 Kit for the R1200ST consists of the Speed Gauge Trim (2 pieces) and Key Guard Trim (3 pieces). These kits really make your bike stand out from the crowd.

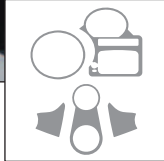

Z8306

Genuine Carbon Fiber Trim

Z8306 Carbon Fiber Trim Set

Fits 2006-07 R1200S.

The Z8306 Trim Set includes the Speed Gauge Trim (2 pieces) and Key Guard/Triple Clamp Trim (2 pieces). Your R-S will look fast even when standing still!

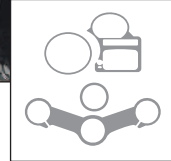

Z8325

Genuine Carbon Fiber Trim

Z8325 Carbon Fiber Trim Set

Fits 2005-08 K1200R and K1200R Sport; 2009-13 K1300R.

The 5-piece Z8325 Carbon Fiber Trim Set for the K1200R and K1200R Sport includes the Speed Gauge Trim (2 pieces) and the Triple Clamp Trim (3 pieces).



Z8604

Genuine Carbon Fiber Trim

Z8604 Carbon Fiber Trim Set

Fits 2006-12 F800S.

The 6-piece Z8604 Carbon Fiber Trim Set is designed specially for the F800S, and includes the Gauge Panel Trim and Upper Triple Clamp Trim components. Get the cutting edge look of carbon fiber without the cutting edge bite on your budget.

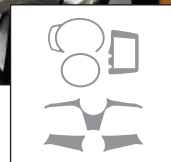

APPEARANCE
AND TRIM

MULTI-FIT

ZTechnik® ZCaps for Clutch/Brake Reservoirs



Z5351

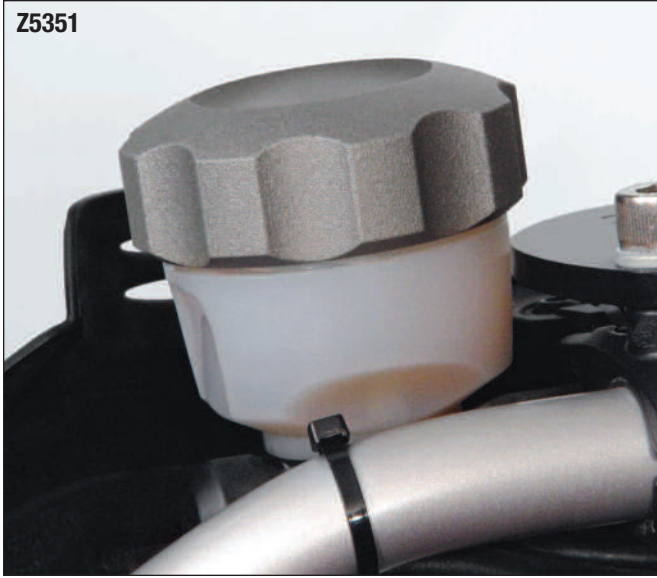

Z5350



Machined Aluminum ZCaps

Z5350 Clutch Reservoir

Fits 2005-08 K1200R, 2005-08 K1200S, 2007-08 HP2 Megamoto, 2004-13 R1200GS (Oilcooled), 2006-13 R1200GS Adventure, 2006-14 R1200R, 2006-07 R1200S, 2005-08 R1200ST, 2009-11 K1300GT, 2009-13 K1300R, 2009-15 K1300S.

Z5351 Brake Reservoir

Fits 2008-12 F650GS Twin, 2013-16 F700GS, 2008-146 F800GS, 2005-08 K1200R, 2005-08 K1200S, 2007-08 HP2 Megamoto, 2004-13 R1200GS (Oilcooled), 2006-13 R1200GS Adventure, 2006-14 R1200R, 2006-07 R1200S, 2005-08 R1200ST, 2009-11 K1300GT, 2009-13 K1300R, 2009-15 K1300S.

Z5352 Brake Reservoir

Fits 2010-15 S1000RR.

Replace the plain plastic reservoir covers with these beautifully machined aluminum replacement caps. They have a beadblasted, durable hard-anodized gray finish to match the Boxer's cylinder head covers. Precise tolerances ensure a perfect and exact fit.

The ZCap's anti-rotational threads hold more securely than other after-market replacement caps, aligning and gripping the OEM reservoir's locking detents.

Complete the look with ZTechnik Machined Aluminum ZPlugs!

Z5352



ZTechnik's anti-rotational threads grip and hold securely to prevent loosening and leakage.

Specifications and Materials



**Machined Aluminum with Anodized Gray Finish;
Direct Replacement – No Tools Required**



ZTechnik® ZPlugs For Frame/Chassis

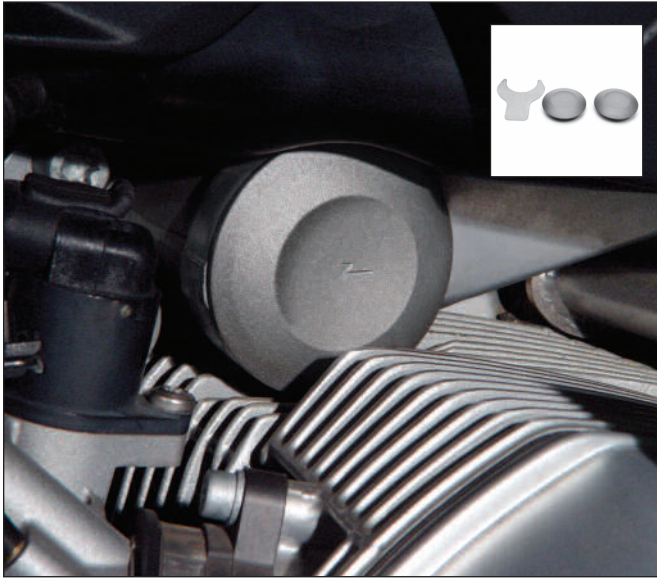

Machined Aluminum ZPlugs

Z5360 Left/Right Telelever Pivots: Pair

Fits 2004-13 R1200GS (Oilcooled), 2006-13 R1200GS Adventure, 2006-14 R1200R, 2005-13 R1200RT, 2006-07 R1200S, 2005-08 R1200ST.

Replace the black plastic frame plugs on the front telelever pivots with these beautifully machined aluminum replacement plugs. They have a beadblasted, durable hard-anodized grey finish to match the Boxer's cylinder head covers. Precise tolerances and channeled rubber o-rings ensure a perfect and exact fit. Kit includes a tool for removing the OEM plastic plugs.

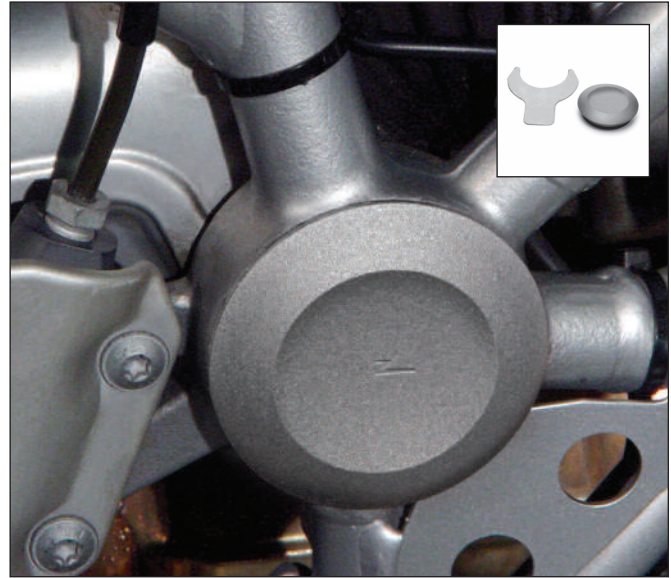

Machined Aluminum ZPlugs

Z5361 Large Right Rear Frame Junction

Fits 2004-13 R1200GS (Oilcooled), 2006-13 R1200GS Adventure, 2006-10 R1200R, 2005-08 R1200ST.

Cover the large hole at the right rear frame junction with this beautifully machined aluminum plug. It has a beadblasted, durable hard-anodized grey finish to match the Boxer's cylinder head covers. Precise tolerances and a channeled rubber o-ring ensure a perfect and exact fit. Includes a tool for removing the OEM plastic plugs.

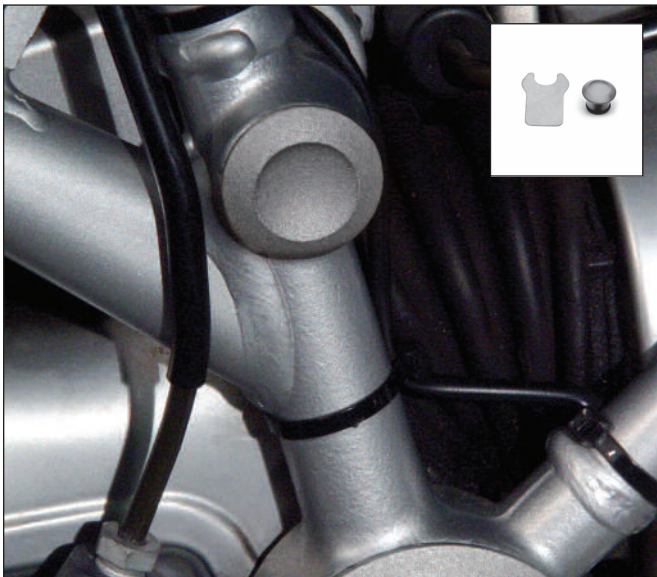

Machined Aluminum ZPlugs

Z5362 Small Right Rear Frame Junction

Fits 2004-13 R1200GS (Oilcooled), 2006-13 R1200GS Adventure.

Cover the small hole at the right rear frame junction with this beautifully machined aluminum plug. It has a beadblasted, durable hard-anodized grey finish to match the Boxer's cylinder head covers. Precise tolerances and a channeled rubber o-ring ensure a perfect and exact fit. Includes removal tool for maintenance access.

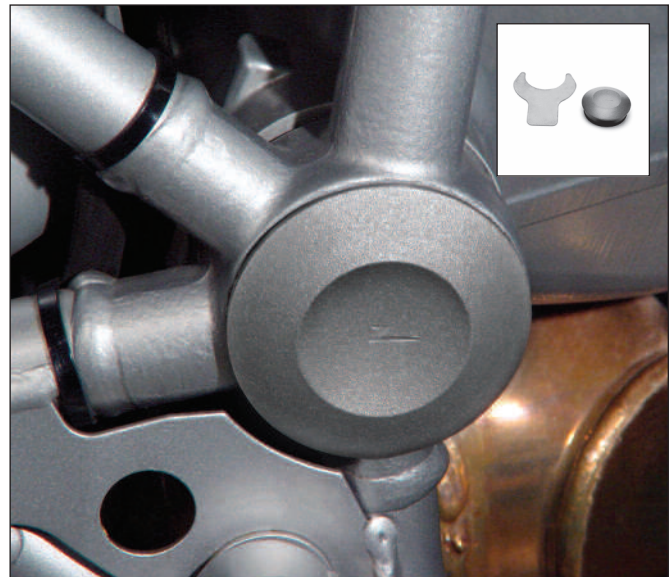

Machined Aluminum ZPlugs

Z5363 Large Left Rear Frame Junction

Fits 2004-13 R1200GS (Oilcooled), 2006-13 R1200GS Adventure, 2005-08 R1200ST.

Replace the black plastic frame plug at the left rear frame junction with this beautifully machined aluminum plug. It has a beadblasted, durable hard-anodized grey finish to match the Boxer's cylinder head covers. Precise tolerances and a channeled rubber o-ring ensure a perfect and exact fit. Includes a tool for removing the OEM plastic plug.



APPEARANCE
AND TRIM

MULTI-FIT

ZTechnik® ZGuards for 2010-14 S1000RR



APPEARANCE
AND TRIM

S SERIES RR



Machined Aluminum ZGuards

Z5600 Chain Guard

Fits 2010-14 S1000RR.

Replace the standard plastic part with this tough aluminum ZGuard Chain Guard from ZTechnik.

Strong, lightweight 5052 aluminum alloy is highly resistant to corrosion from saltwater and other chemicals. Hard anodizing adds another level of corrosion resistance.



The Z5600 ZGuard Chain Guard and Z5650 ZGuard Tire Hugger look great when teamed together, and give the rear wheel a seriously powerful appearance.

Refer to the Technik Application Guide for the latest fitment information and updates.

Materials and Specifications



Machined 14-Gauge 5052 Aluminum, Hard Anodized for Corrosion Resistance



ZTechnik® ZGuards for 2010-14 S1000RR

APPEARANCE
AND TRIM

S SERIES RR

Z5650



The Z5600 ZGuard Chain Guard and Z5650 ZGuard Tire Hugger look great when teamed together, and give the rear wheel a seriously powerful appearance.

Machined Aluminum ZGuards

Z5650 Tire Hugger

Fits 2010-14 S1000RR.

Replace the standard plastic part with this tough aluminum ZGuard Tire Hugger from ZTechnik.

Strong, lightweight 5052 aluminum alloy is highly resistant to corrosion from saltwater and other chemicals. Hard anodizing adds another level of corrosion resistance.

Refer to the Technik Application Guide for the latest fitment information and updates.

Materials and Specifications



Machined 14-Gauge 5052 Aluminum, Hard Anodized for Corrosion Resistance

ZTechnik® Engine Guards for R Series GS/R/RT

NEW



Z7103



Touring, Comfort, and Convenience

Z7102 Stainless Steel Engine Guards

Fits 2010-13 R1200GS (Oilcooled), 2010-13 R1200RT, 2011-13 R1200R.

Z7103 Stainless Steel Engine Guards

Fits 2013-16 R1200GS/Adventure (Watercooled), 2015-16 R1200R, 2015-16 R1200RT.

ZTechnik's Stainless Steel Engine Guards will never rust like powder-coated steel engine guards. They are carefully designed to allow clearance for oil changes or valve cover access, so they don't need to be removed for routine maintenance.

Guards attach to the engine mounts – not the engine covers – to protect the engine heads and not destroy them. Integrated top brackets on each guard allow the rider to mount accessory lights, video cameras, or whatever they can imagine!

For greater comfort on longer rides, mount foot pegs (1" or 2.54cm) to the Engine Guard's lower section.

ZTechnik Engine Guards are media blasted, then electropolished for a textured matte finish.

NOTE: Not compatible with ZTechnik or aftermarket exhaust headers, as they will not allow for installation of O² sensor.

Z7102



Maintenance-Friendly Design and a Handy Accessory Bracket

ZTechnik's Engine Guards are carefully designed to allow clearance for valve cover access or oil changes, so they don't need to be removed for routine maintenance. An integrated top bracket on each Engine Guard allows you to mount aftermarket accessory lights, video cameras or whatever you can imagine (accessible on all but the R1200RT model).

Materials and Specifications



Beadblasted and Electropolished Stainless Steel; 304 Stainless Steel Tubing, Stainless Steel Fasteners; All Hardware Included

TOURING, COMFORT,
AND CONVENIENCE

R SERIES GS/R/RT



ZTechnik® Engine Guards for R Series GS/R/RS/RT/ST



Z7101



Z7105



Z7101

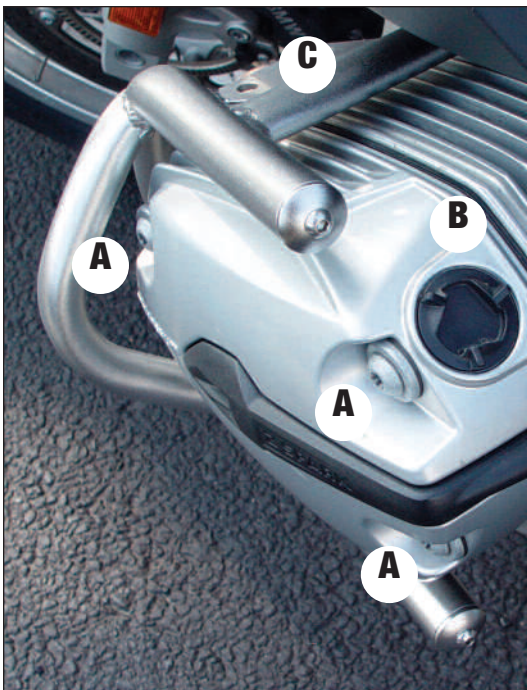

Maintenance-Friendly Design and a Handy Accessory Bracket

ZTechnik's Engine Guards are carefully designed to (A) allow clearance for valve cover access or (B) oil changes, so they don't need to be removed for routine maintenance. An integrated top bracket (C) on each Engine Guard allows you to mount aftermarket accessory lights, video cameras or whatever you can imagine (accessible on all but the R1200RT model).

Touring, Comfort, and Convenience

Z7101 Stainless Steel Engine Guards

Fits 2004-09 R1200GS, 2007-10 R1200R, 2005-09 R1200RT.

Z7105 Stainless Steel Engine Guards

Fits 1996-01 R850GS, 1993-98 R1100GS, 1995-00 R1100R, 1998-05 R1100S, 1993-00 R1100RS, 1994-00 R1100RT, 1999-03 R1150GS, 2001-06 R1150R, 2003-06 Rockster, 2001-04 R1150RS, 2001-04 R1150RT.

ZTechnik's Stainless Steel Engine Guards will never rust like powder-coated steel engine guards. They are carefully designed to allow clearance for oil changes or valve cover access, so they don't need to be removed for routine maintenance.

Guards attach to the engine mounts – not the engine covers – to protect the engine heads and not destroy them. Integrated top brackets on each guard allow the rider to mount accessory lights, video cameras, or whatever they can imagine!

For greater comfort on longer rides, mount foot pegs (1" or 2.54cm) to the Engine Guard's lower section.

ZTechnik Engine Guards are media blasted, then electropolished for a textured matte finish.

NOTE: Not compatible with ZTechnik or aftermarket exhaust headers, as they will not allow for installation of O² sensor.

NOTE: Z7105 will not work on models with twin spark motors.

Materials and Specifications



Beadblasted and Electropolished Stainless Steel; 304 Stainless Steel Tubing, Stainless Steel Fasteners; All Hardware Included

TOURING, COMFORT,
AND CONVENIENCE

R SERIES GS/R/RS/RT/ST

ZTechnik® Trunk Rack for 1998-10 K Series LT



Z9050



Touring, Comfort, and Convenience

Z9050 Trunk Rack with LED Brake Light Fits 1998-10 K1200LT.

Add an elegant and functional addition to your 1998 and later K1200LT. With brazed heavy-gauge steel tube construction, superb chrome plating, and integrated bungee hangers for securing your gear, the ZTechnik Trunk Rack is ready for your next trek.

A drilling template is provided for foolproof installation. Includes BMW wiring couplers for the LED brake light.

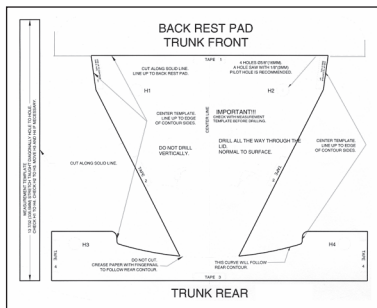

The ZTechnik Chrome Trunk Rack comes with an integrated supplemental LED brake light. It includes BMW wiring couplers for easy, no-mess installation. Your motorcycle has one brake light... but two brake lights are better.

Materials and Specifications



Chromed Steel; Weight Capacity: 5 lbs. (2.25kg);
19.00" (48.3cm) Wide

TOURING, COMFORT,
AND CONVENIENCE

K SERIES LT



ZTechnik® Arm Rests for 1998-10 K Series LT



ZTechnik Passenger Arm Rests easily rotate out of the way when you need them to.



The solid mounted hardware lets the Arm Rests rotate smoothly rearward to facilitate easy passenger dismounting or for access to the trunk. ZTechnik determined the optimum position and height of the Arm Rests by field testing with different passengers. This ensures maximum long-distance comfort for your passenger.

Touring, Comfort, and Convenience

Z9401A Passenger Arm Rests

Fits 1998-10 K1200LT.

Add comfort, luxury, functionality, and style to your bike. Our ergonomic Arm Rests are precision-machined aluminum for a perfect fit and silky smooth operation at the pivots.

The Arm Rests mount to the rear trunk with stainless steel hardware via a hidden backing plate. Installation is easy with do-it-yourself instructions and a mounting template.

Materials and Specifications



Precision Machined Aluminum with Stainless Steel Mounting Hardware; Color-Matched Silver Powder Coat

TOURING, COMFORT,
AND CONVENIENCE

K SERIES LT



Touring, Comfort, and Convenience

Z5505A License Plate Bracket Helmet Locks

Fits All USA, Canadian and Australian Models.

Z5506 License Plate Bracket Helmet Locks

Fits All Japanese Models.

The ZTechnik Helmet Lock for BMW motorcycles uses the easily accessible license plate bracket to provide leave-behind security for two full-face helmets. A sturdy push-lock mechanism accepts D-ring or similar helmet closures.

The Helmet Lock is made from high strength steel with black powdercoat, and is furnished with two matched keys.

Note: Because the state of Wisconsin does not comply with SAE license plate standards, fitment of Wisconsin plates to the Z5505A is marginal. Wisconsin plates may be mounted, however only the top two holes will match the plates.

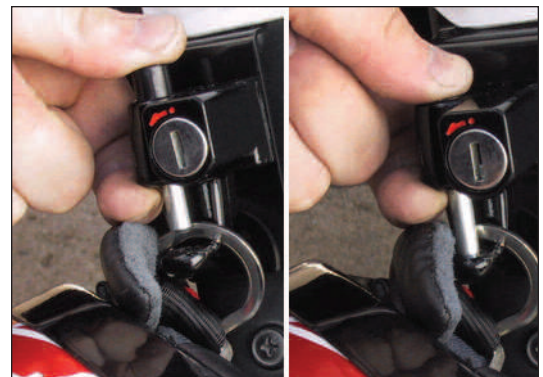

Slip the D-ring behind the lock bar and push the lock shut. Simply use your key to unlock the helmets when it's time to go.

Materials and Specifications



High Strength Steel with Black Epoxy Powdercoat;
Uses Existing License Plate Hardware and Fasteners;
Height: 6.50" (16.5cm); Width: 6.75" (17.1cm)



ZTechnik® Great Ideas for All BMW® Motorcycles



Three main zippered storage pockets plus document/map compartment on a cleverly designed removable tray

There's room for storage beneath the tray, or remove the tray altogether for one large compartment



*Shown on
R1200ST*



*Shown on
K1200R*

The Storage Pod's web straps and rubber coated hooks typically attach to a bike's seat pan edge. The straps are tightened with D-rings inside the Pod itself. The double zippers make it easy to attach a small padlock.

Touring, Comfort, and Convenience

Z1210 Storage Pod

Fits All Models.

ZTechnik's extremely versatile 4-liter rear Storage Pod offers a stylish and practical way to carry the essentials. It features a Velcro® fastened, removable tray with three zippered storage pockets and a zippered document/map holder.



Sturdy double zippers keep everything secured inside while the Pod's web straps and rubber coated hooks attach it to the bike.

The dense thermo-molded Pod is covered with a durable canvas outside with a soft inner shell.

Materials and Specifications



Durable Black Canvas Over a Thermo-Molded Pod;
All Mounting Hardware Included; Height: 4.50-6.00" (11.4-15.2cm);
Width: 9.00-12.50" (22.9-31.8cm); Length: 13.75" (35.0cm)

**TOURING, COMFORT,
AND CONVENIENCE**

MULTI-FIT

ZTechnik® Accessory Mounts



Mounting electronic accessories to your BMW® motorcycle with ZTechnik Accessory Mounts is as easy as 1-2-3!

- 1 What do you want to mount? A GPS? Radar detector? An MP3 player? Something different?
- 2 Find the adaptor, top plate or cradle that will hold your accessory.
- 3 Find the mount that secures your accessory to your specific motorcycle.

ZTechnik's 4th Generation Accessory Mounts are designed to fit perfectly and to last as long as your bike.

There are Mounts specially made for specific models as well as Mounts that are universal to a number of BMW motorcycles. In most cases, you can choose from a range of different Accessory Mounts to suit your needs.



ZTechnik's 4th Generation Accessory Mounts are made from super strong 6061 T6 Aluminum and are finished in Anodized Black, Anodized Silver, and Brilliant Chrome. All screws and bolts are polished stainless steel. All Accessory Mounts include installation instructions, mounting hardware, installation tools, and (where needed) Velcro® industrial fasteners.

Whichever Accessory Mount you choose, you will also have a wide variety of accessories and adapter plates that allow you to mount almost any electronic device you may want to bring along on your ride.

So no matter where you go, you CAN take it with you!

ZTechnik Adapters and Top Plates



Small GPS/XM Top Plate
Z6041 Black Z6042 Silver
Z6043 Chrome

For mounting devices with the 4-hole AMPS pattern. Uses rubber bushings to hold devices securely and to isolate vibration. Works with Garmin®, Tom Tom® and RAM-Mount GPS cradles.



Z6053 XM Antenna Bracket
Z6054 GPS/XM Antenna Bracket

Z6053 provides a magnetic mounting platform for satellite radio antennas. Mounts between Top Plate and attached device. Z6054 mounts your Garmin® antenna. Use fasteners supplied by Garmin to secure antenna.



Z6059 Adapter; 4-Square Pin to Single Pin Male

Converts 4-hole AMPS pattern on ZTechnik Accessory Mount Top Plates to single pin male mounting. Allows single slot accessories to be mounted onto ZTechnik top plates.



Z6060 Adapter; 4-Screw AMPS to 4-Square Pin Male

Converts 4-hole AMPS pattern on ZTechnik Accessory Mount Top Plates to 4-square pins. Allows 4-square slot accessories to be mounted onto ZTechnik top plates.



Z6061 Adapter; 4-Screw AMPS to Dual T Pin (Male)

Converts 4-hole AMPS pattern on ZTechnik Accessory Mount Top Plates to Dual T pins. Allows Dual T slot accessories to be mounted onto ZTechnik top plates.



Radar Detector Top Plate Kit
Z6428 Black Z6441 Silver
Z6429 Chrome

Radar Detector Accessory Top Plate with anti-slip pads and safety strap and 4th Generation 17mm ball socket adapter.

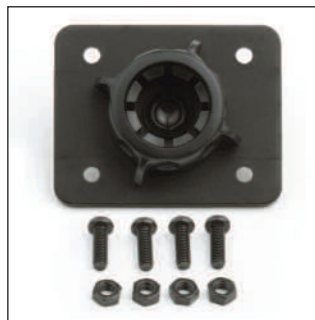

Z6430 Multi-Use Rectangular Top Plate

Multi-Use Rectangular Accessory Top Plate with 4-hole AMPS pattern pre-drilled. Top plate is 2.25" (57.15mm) x 1.87" (47.5mm).



Z6431 Universal 17mm Ball Adapter

Allows any existing ZTechnik Accessory Mount top plate to convert to the current 4th Generation 17mm ball shaft.

TOURING, COMFORT,
AND CONVENIENCE

MULTI-FIT



ZTechnik® Accessory Mounts

ZTechnik Adapters and Top Plates



Z6432 Universal Camera Mount
Universal camera mounting adapter for 4th Generation 17mm ball shaft. Fits universal tripod socket on most still and video cameras.



Z6433 GoPro™ Adapter
ZAdapts the GoPro camera to the 4th Generation 17mm ball shaft.



Z6434 RAM Cradle Adapter
Two-hole diamond shaped adapter that allow any RAM cradle to attach to any 4th Generation ZTechnik Accessory Mount.



Z6435 Large Device Holder
Secure holder for large cell phone or other devices. Features a safety strap and Dual-T adapter.



Garmin® Zumo™ Top Plate
Z6442 Black Z6443 Silver Z6444 Chrome
Accessory plate required for mounting a Garmin® Zumo™ to any 4th Generation ZTechnik Accessory Mount.

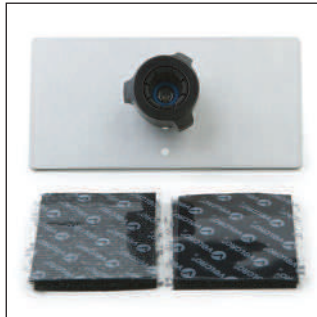

Extra Wide Top Plate
Z6445 Black Z6446 Silver Z6447 Chrome
Wide Top Plate for mounting accessories such as a large GPS or radar detector. Mounts to any 4th Generation Accessory Mount.



Dual Top Plate
Z6458 Black Z6448 Silver Z6449 Chrome
Mount two devices to the same mount! Dual 4-hole AMPS pattern 3.0" x 2.25" plates swivel independently.



Round Top Plate
Z6467 Black Z6468 Silver Z6469 Chrome
Round 2.25" top plate with 4-hole AMPS pattern for any 4th Generation Accessory Mount.



Z6476 TechGripper
TechGripper's spring-loaded, soft rubber jaws will hold any device at any angle. Grabs hold of your device and won't let go, yet releasing it is effortless!



ZTechnik® Accessory Mounts



Smart Phone/Tablet/GPS Accessories



Water Resistance Cases

- Z6436** 3.4x5.3x1.7" GPS
- Z6437** 3.4x6.0x1.0" Mini-Tablet
- Z6438** 3.0x4.3x1.0" Cell Phone

Zippered, water resistant cases with clear window allow easy use of your device's touchscreen. Foam inserts provide a secure, custom fit. Water resistant entry point for power and other cables.

Mounts to any ZTechnik Accessory Mount 4th Generation ball socket.



Moto-Clip

- Z6451** iPhone® 4/4S
- Z6453** iPhone® 5

Use with a LifeProof® Case to mount your phone to any 4th Generation ZTechnik Accessory Mount. Slim and lightweight ABS plastic includes ball socket and bolt to secure your Moto-Clip to your 4th Generation Accessory Mount, replacing the standard top plate.

Simply insert your LifeProof-cased phone into the Moto-Clip, push down the sliding lock, and away you go!



Moto-Clip with Belt Clip

- Z6452** iPhone® 4/4S
- Z6454** iPhone® 5

Use with a LifeProof® Case to attach your phone to your belt. Includes clips for 1.5" and 2.0" belts.

Simply insert your LifeProof-cased phone into the Moto-Clip, push down the sliding lock, clip it onto your belt, and away you go!



LifeProof® Phone Cases

- Z6069** iPhone® 4/4S
- Z6450** iPhone® 5

This case gives you the freedom to make your phone your constant companion – on your motorcycle or anywhere else! It has a full IP-68 rating against water and dust, and is designed to military specifications.

The UltraFlat scratch resistant screen protector assures multitouch functionality. Optical glass anti-reflective lens maintains high quality images, while waterproof acoustic vents keeps the sound real.

A gold-plated general use headphone adapter is included.

Z6472



LifeProof® frē Phone Cases

- Z6470** iPhone® 5C
- Z6471** iPhone® 5S
- Z6472** Samsung® Galaxy S3
- Z6473** Samsung® Galaxy S4

LifeProof's original and proven case technology... but thinner, lighter, stronger and better. LifeProof's original touchscreen protection is still the best. Like an ultra-flat, optically clear force field, it safeguards the touchscreen while allowing full access and functionality.

LifeProof upped the protection game by reducing bulk. Stuffing an amazing amount of protection into a small package makes these the thinnest, lightest all-protective case available. It's completely waterproof, dirt proof, snow proof and shock proof.

It's LifeProof!

A gold-plated general use headphone adapter is included.



ZTechnik® Accessory Mounts

ZTechnik Accessory Mount Replacement Shafts



Accessory Mount Replacement Shaft
Z6414 Black **Z6415** Silver
Z6440 Chrome
 1-inch straight shaft for 4th Generation ZTechnik Accessory Mounts.



Accessory Mount Replacement Shaft
Z6416 Black **Z6417** Silver
Z6418 Chrome
 2-inch pivoting shaft for 4th Generation ZTechnik Accessory Mounts.



Accessory Mount Replacement Shaft
Z6419 Black **Z6420** Silver
Z6421 Chrome
 2-inch straight shaft for 4th Generation ZTechnik Accessory Mounts.



Accessory Mount Replacement Shaft
Z6422 Black **Z6423** Silver
Z6424 Chrome
 3-inch pivoting shaft for 4th Generation ZTechnik Accessory Mounts.



Accessory Mount Replacement Shaft
Z6425 Black **Z6426** Silver
Z6427 Chrome
 3-inch straight shaft for 4th Generation ZTechnik Accessory Mounts.



Accessory Mount Replacement Shaft
Z6459 Black **Z6460** Silver
Z6461 Chrome
 1-inch shaft with 1-inch pivoting arm for 4th Generation ZTechnik Accessory Mounts.



Accessory Mount Replacement Shaft
Z6462 Black **Z6463** Silver
Z6464 Chrome
 1-inch shaft with 2-inch pivoting arm for 4th Generation ZTechnik Accessory Mounts.

NOTE: These Replacement Shafts can upgrade most 3rd Generation Accessory Mounts to accept 4th Generation ball socket top plates, adapters and accessories.

ZTechnik Accessory Mounts



Z6405 BMW Steering Stem Mount
 Universal stem mount fits the steering stem nut of the 2010-14 S1000RR. Uses an O-ring shaft that gets progressively tighter as it is installed. Mounts devices center of the top triple clamp. Includes O-ring posts in 13mm, 16mm, 17mm, 18mm, 19mm and 24mm.



Z6410 Mount with Z6468 Top

Z6407 Mount with Z6467 Top

Z6409 Mount with Z6467 Top

ZTechnik® Accessory Mounts



ZTechnik Accessory Mounts



Z6406 BMW Mirror Mount
BMW Mirror Mount fits into the unused mirror holes on the left or right side of the K1200GT, K1300GT, K1200LT and 2005-13 R1200RT.



Z6407 BMW Fork Cap Mount
Fork Cap Mount systems mount onto the fork tube oil filler bolts found on many late model BMW motorcycles.



Z6408 GS Fairing Mount
Mounts onto the upper windscreen support bracket of the R1200 GS Adventure windscreen, or the same position on ZTechnik's Z2422 or Z2423 VStream® Windscreen for the R1150 GS Adventure.



Z6409 BMW Control Mount
BMW Control Mount fits onto the handlebar control pinch bolts (clutch or brake side). Fits BMW control mounts having two vertical pinch bolts facing the top of the mount. *Note: Fits K1600GT clutch side only.*



Z6410 R-RT Center Mount
Z6411 K-GT Center Mount
The Z6410 Center Mount fits 1994-13 R1100RT, R1150RT and R1200RT. Z6411 Center Mount fits 2006-10 K1200/1300GT.



Z6412 Handlebar Mount; Black
Z6413 Handlebar Mount; Silver
Z6474 Handlebar Mount; Chrome
Basic Handlebar Mount Kit fits all tubular handlebars from 7/8" (22mm) to 1-1/4" (32mm). Adapters are included.



Z6465 Fork Tube Mount; Black
Z6466 Fork Tube Mount; Silver
Mounts onto the 55mm fork tube of the S1000R and S1000RR. Easily installed by sliding the clamp over the fork tube that protrudes from the top fork brace and tightening the tension screw. Can be mounted on either left or right side.



Z6475 BMW Control Mount
BMW Control Mount fits onto the handlebar control pinch bolts (clutch or brake side). Fits later-model BMW control mounts having two horizontal pinch bolts facing the rear of the mount. Includes longer stainless steel bolts and spacers.

Z6476 TechGripper
and **Z6413 Accessory Mount**
on an R1200GS Adventure





ZTechnik Accessory Lighting Mounts

Z6024 Auxiliary Light Bar Kit

Mounts onto any 2004-13 BMW R1200GS (oilcooled) or 2006-13 R1200GS Adventure. The Light Bar Kit attaches to the lower fairing support under the front fender assembly. Provides a secure mounting location for aftermarket accessory lighting. Lights can be mounted on top of the bar or hung from underneath (lights not included).

Finished in anodized black, with stainless steel fasteners and complete installation instructions.



Your auxiliary lights can be mounted on top of the Z6024 Light Bar Kit, or suspended from underneath (lights not included).



Z6026 Light Mount Kit

These easily installed brackets mount to the headlight adjuster bolts on 2013-16 F700GS, 2008-16 F800GS and 2008-12 F650GS Twin. They will mount most auxiliary lights with 10mm mounting posts (lights not included).



Z6439 Light Mount Kit

These easily installed brackets mount to the headlight adjuster bolts on 2013-16 F700GS, 2008-16 F800GS and 2008-12 F650GS Twin. They will mount PIAA® 1100X or similar auxiliary lights (lights not included).



Z6020 Light Clamp Kit; Black Z6021 Light Clamp Kit; Silver Z6022 Light Clamp Kit; Chrome

Will mount onto any 7/8", 1" or 1-1/8" tubular handlebar, crash bar, or frame tubing with the included adapters.

Pre-drilled light mounting brackets can be rotated 360 degrees, offering complete versatility for placement and positioning of lights (lights not included).



Z6027 Auxiliary PIAA Thumb Switch Mount

Replace the stock M5x20mm fastener securing the left or right handlebar control assembly with this M5x40mm screw and spacer.

It positions the thumb-operated PIAA light switch closer to the handgrips (light switch not included).





national cycle[®]

WORLD'S FINEST MOTORCYCLE WINDSHIELDS AND ACCESSORIES SINCE 1937



Catalog 1
Windshields and Their Accessories
for American and Metric Motorcycles

Catalog 2
VStream® Windscreens for
American and Metric Motorcycles

Catalog 3
Quality Riding Accessories for
American and Metric Motorcycles

Catalog 4
Wash'n'Wipe™ Windshields for
SxS UTVs and ATV Windshields

OUT IN FRONT™ Accessory System

The First Windshield Integrated Front End Accessory System

A **Windshield**, a **Light Bar**, and a set of **Chrome Lowers** – three popular accessories that are designed and engineered together to achieve a correct and exact fit on your model motorcycle.

**SwitchBlade®, Spartan®,
Heavy Duty™, Dakota 4.5™**

See Catalog 1

Hand Deflectors

See page 05

Spotlight Bars

See pages 04

Chrome Lower Deflectors

See page 04

Cast Fender Tips

See pages 06-07



SwitchBlade® or Spartan®
Windshields



Heavy Duty™ Windshields



Chrome Lower Deflectors



National Cycle Spotlight Bars

Purchase all your front end components from National Cycle and know that they will work together. And don't forget – we also have Highway Bars, Hand Deflectors and Fender Tips that work with our Out In Front accessories.

Spotlight Bars and Chrome Lower Deflectors

National Cycle Spotlight Bars not only look great on your cruiser, they are also a considerable safety feature. Their 35-watt halogen bulbs light up the night on those long, dark roads and, at the same time, make you more visible to oncoming traffic.

Our Spotlight Bars are wired for activation with your headlight bright switch, but with our N9001 accessory switch, they can be turned off when supplemental lighting is not needed.

National Cycle manufactures a complete line of Spotlight Bars and guarantees the fit of the light bar with our windshields. We engineer complementary clearances to ensure the Spotlight Bars will fit with our SwitchBlade, Heavy Duty and Dakota 4.5 windshields, and with our Chrome Lowers.

National Cycle's Spotlight Bars are assembled and wired for easy installation. All Spotlight Bars parts are replaceable. Made in America by National Cycle.

ALSO AVAILABLE:

N9001 Spotlight Bar On/Off Switch
for 1" Handlebars

N9005 Spotlight Visors
Sold in pairs



National Cycle Spotlight Bars are custom designed for each make and model motorcycle.

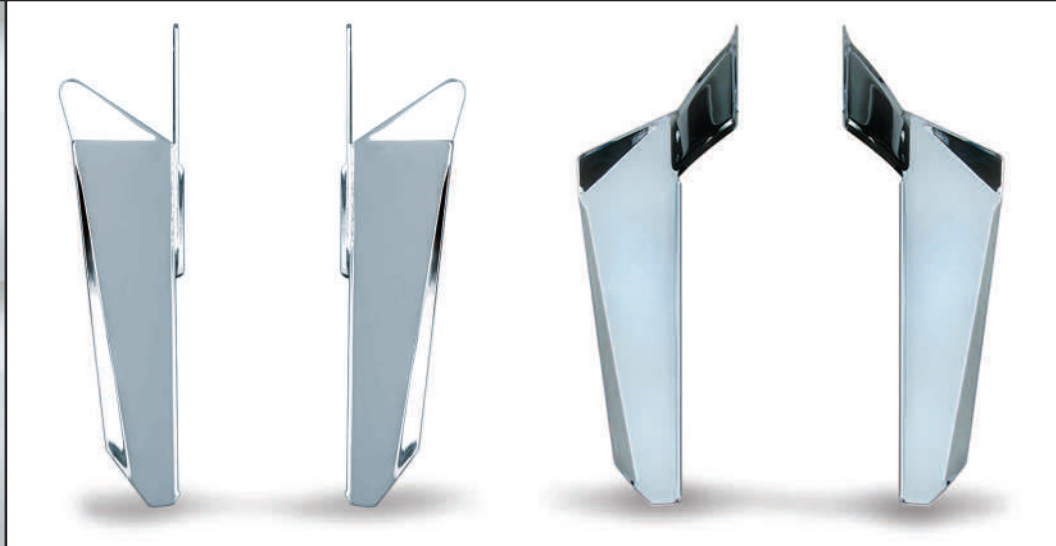

All National Cycle Light Bars use DOT and European "E" Mark Lights.

N9001



N9005

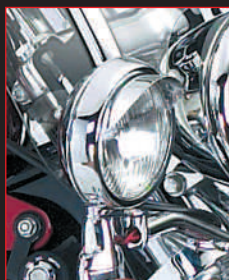

Chrome Lower Deflectors improve the performance of your windshield by preventing unwanted turbulence. Chrome Lowers can be used together with a SwitchBlade®, Heavy Duty™ or Dakota 4.5™ windshield and a National Cycle Light Bar for an integrated front end appearance.

We engineer our Chrome Lowers with our other accessories for proper clearance and performance. We consider Chrome Lowers a key component to your front end look and guarantee the fit of the product with our SwitchBlade, Heavy Duty and Dakota Windshields, and with our Light Bars.

Superb polishing and chrome plating make National Cycle Chrome Lowers really stand out.

SIZE

Chrome Lowers are application specific to ensure the correct fit for your motorcycle.

MATERIAL



HARDWARE



Mounts to National Cycle Quick Release or Heavy Duty Mount Kits

National Cycle Hand Deflectors

Do you hate chilly and damp hands? Does the riding season seem too short?

National Cycle Hand Deflectors are an easy-to-install solution for keeping your hands warm and dry. Coupled with a windshield, Hand Deflectors protect your entire upper body from cold wind and rain.

Hand Deflectors mount easily and securely to your bike's mirror mounts, yet allow plenty of room for lever movement and for riders with large gloves. These hand deflectors make a windshield function like a fairing.

MATERIAL



HARDWARE

Mount to existing OEM mirror mounts



National Cycle Hand Deflectors are an economical, easy-to-install solution for riders of standard and sport-touring bikes, too. They extend the riding season when winter gloves are just not enough. They also make heated grips work more effectively.



Applications for Hand Deflectors will vary depending on make and model of motorcycle. To ensure an exact fit, refer to the "SHOP" section of our web site or call your National Cycle dealer.

How Low Can You Go?

Cold wind blasts can rapidly cool your body temperature and reduce your riding time. If the outside temperature is 30 degrees Fahrenheit and you're riding at a speed of 50 mph, the wind chill temperature that your body will feel is 12 degrees Fahrenheit.

The National Weather Service implemented a replacement Wind Chill Temperature (WCT) index several years ago. The new formula uses advances in science, technology, and computer modeling to give everyone a more accurate and useful formula for calculating the dangers from winds. Our chart is based on the new WCT formula.

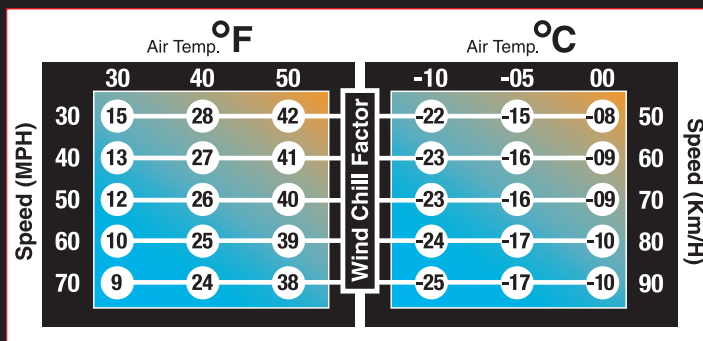

Traditional Cast Fender Tips

N7019

Create the perfect fender treatment for your cruiser motorcycle! **Cast Fender Tips** are an economical way to add that finishing touch to your customized bike. This hallmark product of National Cycle has been painstakingly refined for today's cruisers. By casting the product, the shape and high crown details that distinguish these tips really stand out. These are not ordinary fender tips. These cast tips have a show bike polish with a jewel-quality chrome finish.

Our Cast Fender Tips are available for most models in three applications: front of front fender, back of front fender, and back of rear fender. Get all three and add some real sparkle to your bike!

MATERIAL



HARDWARE

All mounting hardware included



N7020



National Cycle **Cast Fender Tips** are custom designed and clay modeled directly on the bike. They are sized for each model's front and rear fenders, so sizes will vary.

They are easy to install and come with concealed screw mounts or countersunk outside screws (depending on model) for the cleanest possible appearance.

It will be hard to find an accessory that will add so much to your bike at such a reasonable cost.



N7023

2-Piece Front Fender Tip Set



Traditional Cast Fender Tips

We have more than 50 models of **Cast Fender Tips** available for Harley-Davidson, Honda, Indian, Kawasaki, Suzuki, Triumph and Yamaha motorcycles. Plus, new Fender Tip applications are constantly in development.

To check for new applications, go to the "SHOP" or "NEWS CENTER" section of our web site, or call your dealer.

N7048

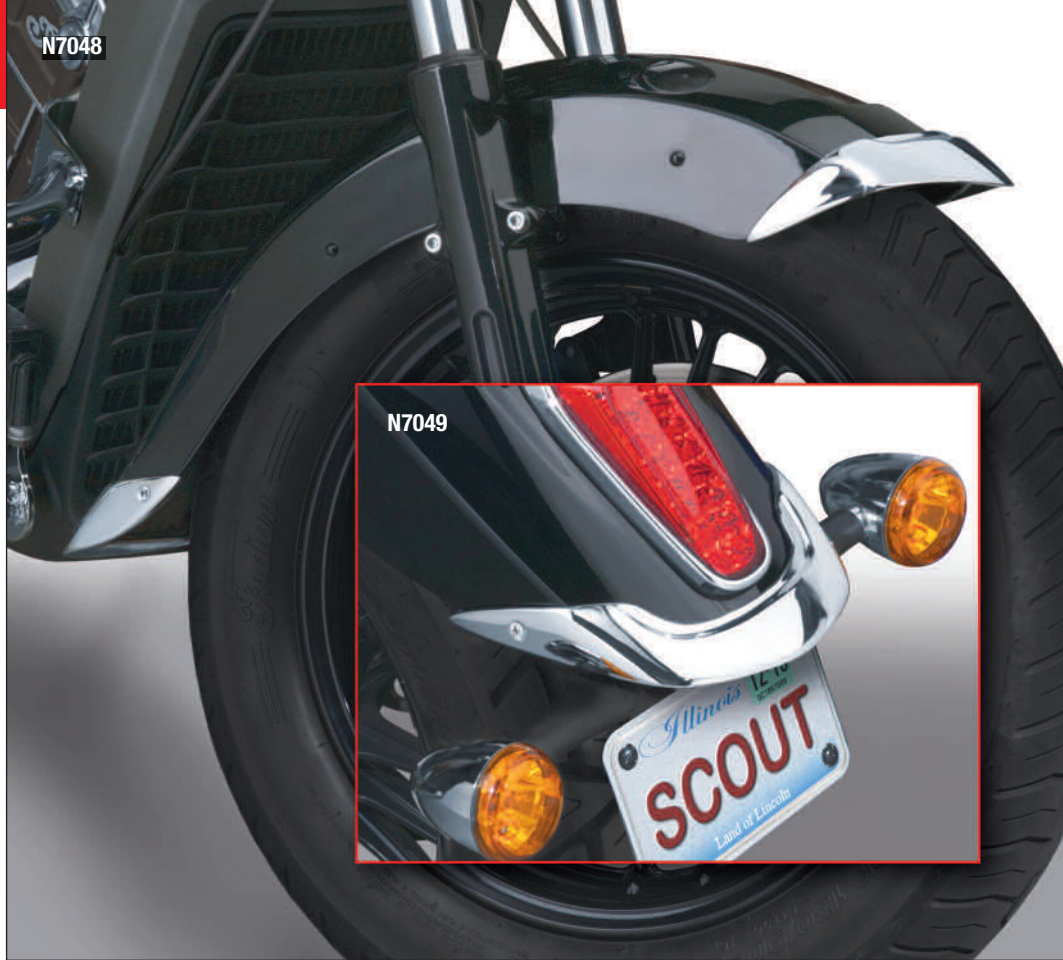

N7049

N712



N7046

Front of Front

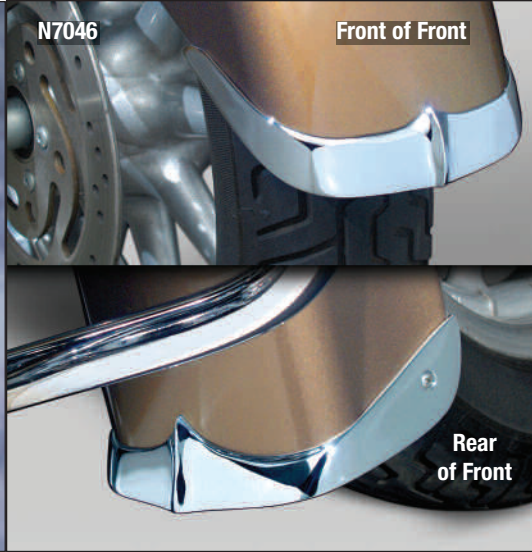

Rear
of Front

N7047



Rear of Rear

Rear Fender Tip



Rear of Rear
Fender

Speedometer Cowl

National Cycle's Chrome Speedometer Cowl keeps glare off the glass speedometer face. No more trouble seeing instruments in bright sunlight, or having the backlit read-out reflect on windshields at night.

Both problems are cured with this attractive chrome accessory... not that you needed another excuse to add attractive chrome!

Available for most Harleys and metric cruisers with tank console speedometers.

N7840



Cruiseline™ Quick Release Hard Saddlebags

N1101
Smoothback

Cruiseline™ Saddlebags are styled for cruisers. Unlike other bags, Cruiseliners are not bilaterally symmetrical – this enables a tight fit and streamlined styling that flows with the lines of the fender.

Cruiseline saddlebags open easily with a “thumb push” lock that flips the lid forward for easy access to items. The quality hinge permanently fastens the lid to the bag. The interior walls, lid, and seal are designed to keep the contents safe and dry.

We still manufacture our famous Cruiseline saddlebags at our factory in Maywood, Illinois. Each year, we offer updated mounting frames for new model cruisers, so no matter what you ride – old or new, big or small – we have Cruiseline saddlebags to fit your bike.

SIZE

Length: 24.50" (62.2cm)
Height: 14.00" (35.5cm)
Width: 07.50" (19.0cm)

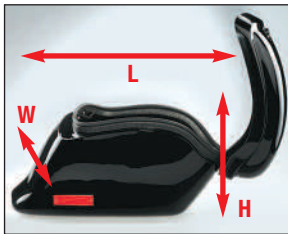

MATERIAL

Molded from an extremely durable polymer blend. Pre-painted gloss black.

CAPACITY

22 liters each.



A quick-detach quarter-turn fastener is located securely inside the bag for “no-tool” quick removal of the saddlebags from the frame.



One key locks both saddlebag lids securely.

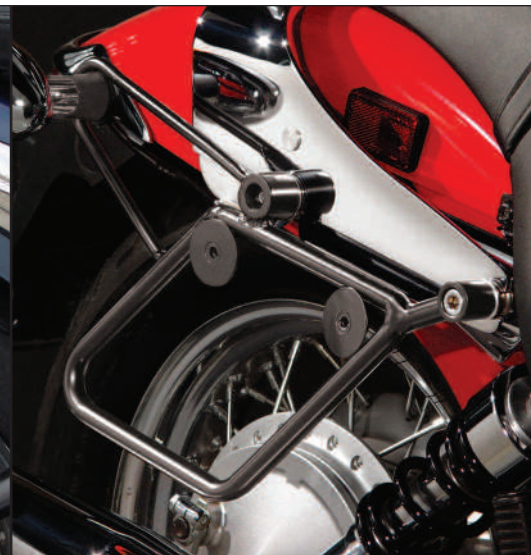

Cruiseline Saddlebags and Mount Kits are available in Black Powdercoat with some applications in Chrome for a wide range of early and late model metric and American cruisers.

New models are always being added. For specific application information, check the “SHOP” section of our web site



Also available is our **Replacement Lock Set** for Cruiseline Saddlebags.

Cruiseline™ Quick Release Hard Saddlebags

The same attention to detail goes into our bags and mounting hardware that has gone into our other products for the past three-quarters of a century.

Every Cruiseline™ saddlebag frame is engineered directly on the motorcycle. All models of frames are finished in a bright chrome, with the majority of models also available in a lower priced gloss black epoxy powder coat finish.

Special Note: National Cycle manufactures Cruiseline saddlebags to mount to a stock motorcycle. All applications requiring the Pocketback style bags (N1100) can use a Smoothback bag (N1101) as long as the motorcycle's turnsignals are changed or customized for clearance.

N1100 Pocketback style for turn signal clearance.
Red reflector (U.S.A. DOT). 

N1102 Pocketback style for turn signal clearance.
Amber reflector (European). 

N1101 Smoothback style.
Red reflector (U.S.A. DOT). 

N1103 Smoothback style.
Amber reflector (European). 

N1100 Pocketback



Cruiseline saddlebags are supplied painted with quality, high gloss black paint. Custom painting is easy to do directly over the stock paint. Professional painters recommend a light wet sanding with 400 grit. Then you're ready to paint with any automotive type paint.

KIT-SBC405 with N1100



KIT-SBC405 with N1101



Which Cruiseline Style is Right For You?

Choose the "pocket back" style (**N1100/N1102**) if you wish to retain the stock turn signals mounted on the rear of the fender struts. These bags feature a cutout for turn signal clearance.

If you decide to use an OEM or aftermarket turn signal relocation kit, or if your turn signals have already been mounted by the taillight, you can use the "smooth back" style (**N1101/N1103**).

National Cycle's **KIT-SBC405** (shown above) for late model Sportsters® includes all the hardware required for turn signal relocation. With KIT-SBC405, you can choose the turn signal placement and Cruiseline saddlebag style that's right for you.

Cruiseline™ Inner Duffel Bags

N1350

One of the most practical accessories you can add to your motorcycle is a set of Cruiseline™ Saddlebags. Now practicality gets practically perfect with our N1350 **Inner Duffels** for Cruiseline Saddlebags.

The inner duffel is stitched to shape so it fits easily into the compartment of the hard bags. The generous size conforms to the inside cavity with room to spare.

This well-constructed duffel is made from 600 denier polyester with a waterproof coating. A two-way zipper allows easy access in and out of the bag.

These features, along with the sturdy nylon web handles, make it easy to remove and carry your cargo without removing the saddlebags from the bike.



National Cycle Storage Pod

N1370

The extremely versatile, 4-liter N1370 **Storage Pod** is a great addition or alternative to the standard tank bag.

In addition to the main compartment, three zippered storage pockets and a map compartment are attached to a cleverly designed removable tray. If you need one large storage area, the Velcro® hinge makes removal of the tray a snap.

Sturdy double zippers keep everything secured inside while the Pod's web straps and coated hooks attach it to the bike.

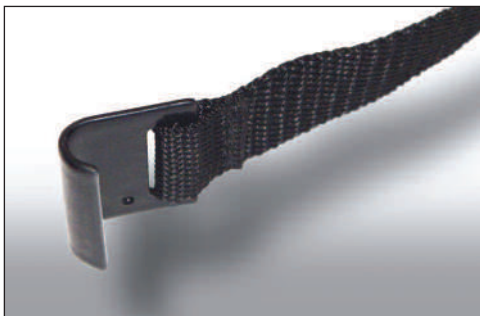

National Cycle Holdster™ Windshield Bags

National Cycle **Holdster™** Windshield Bags offer convenient up-front storage for your gloves, sunglasses, cell phone, garage door opener, tools, etc. Glove-friendly Velcro® closures allow easy one-hand access to your stuff.

Unlike leather tool kits that tend to dry out and become stiff with use, our road-rugged, heavy gauge synthetic leather bags will stand the test of time.

SIZE

N1310 Triple Holdster

11.5" x 5.0 x 3.0" deep (29.2 x 12.7 x 7.6cm),
two side pouches 4.5" x 4.5" x 3.0" deep (11.5 x 11.5 x 7.5cm)
Fits: Wide Frame Heavy Duty windshields including Chopped, Touring, One Piece and Beaded.

N1320 Single Holdster

11.5 x 5.0 x 3.0" deep (29.2 x 12.7 x 7.6cm)
Fits: Narrow Frame Heavy Duty windshields including Ranger, Custom and ATV N2573/N2574.

N1321 Single Holdster

12.5 x 5.0 x 3.0" deep (31.8 x 12.7 x 7.6cm)
Fits: SwitchBlade windshields including 2-Up, Chopped, and Shorty.

MATERIAL

Black, heavy gauge synthetic leather with reinforced back. UV protection and mildew resistant coatings.

N1320



N1321



N1310



National Cycle Windshield Storage Bag

National Cycle's generously-sized **Windshield Storage Bag** will keep your windshield safe and secure when not in use.

The outer bag is 600 denier polyester with a durable, water-proof backing. Industrial-strength zippers, oversized zipper pulls and Tek 70™ industrial thread ensure lasting quality. Inside, your windshield is cradled in a thick, soft pad to provide scratch-free protection for your windshield.

Every rider will appreciate these convenient Windshield Storage Bags!

SIZE

N1351 Windshield Storage Bag

Fits up to our largest windshield (SwitchBlade 2-Up)



N1351

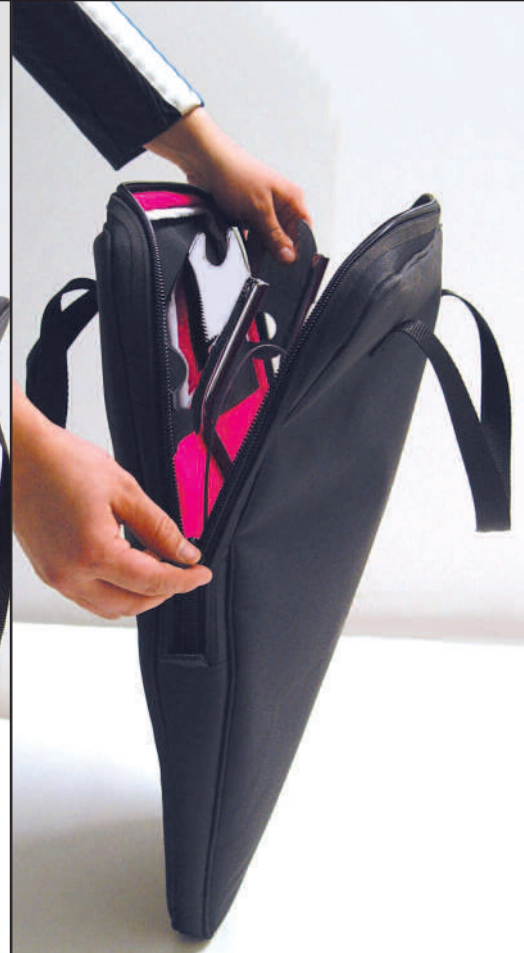

Paladin® Sport Luggage Rack for EX300 Ninja™

P9303

Our stylish and sturdy **Sport Luggage Rack** was designed specially for the new EX300 Ninja™ to greatly improve the carrying capacity. The roomy rack surface with three bungee attachment points on each side allows riders to carry a decent sized duffel bag.

The rack is made from precision, laser-cut aluminum, and the mounting bracket is made from precision cut and formed steel. Both integrate seamlessly with the lines and style of the EX300.

P9303 Sport Luggage Rack

SIZE

Length: 08.25" (21.0cm)

Width: 06.75" (17.1cm)

MATERIAL



HARDWARE

All mounting hardware included



Paladin® Backrest/Luggage Rack for XV250/XVS250 V Star™

P9301/P9302

This **Backrest/Luggage Rack** is made specially for the 2007 and later Yamaha XV250 Virago/XVS250 V Star. This is not a QuickSet™ system – it mounts securely to the frame, rear fender, and turn signal brackets.

And it perfectly matches the bike's style.

P9301 Backrest (Comfort Pad included)

SIZE (Comfort Pad)

Height: 09.50" (24.1cm)

Width: 07.00" (17.8cm)

P9302 Luggage Rack

SIZE

Length: 09.50" (24.1cm)

Width: 09.50" (24.1cm)

MATERIAL



HARDWARE

All mounting hardware included



The **P9303 Sport Luggage Rack** has three attachment points on each side (six total) so there are plenty of ways to attach bungees or tiedown straps to carry your gear.

P9302

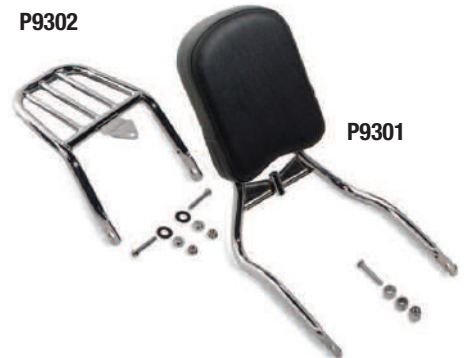

P9301

The **P9301 Backrest** can be mounted alone for carrying passengers. But with passengers, there is always extra gear to carry. Then you can simply add on the **P9302 Luggage Rack**.

Paladin® Solo Luggage Rack for Indian® Scout

P9500

The Indian® Scout solo rider gets something special that we've never done before – a fender mounted Solo Luggage Rack that looks like it came off a 1942 Indian Sport Scout.

This high quality, rolled tubular steel rack bolts onto the passenger seat mount points. Add a set of our Cruiseline™ Saddlebags and you're ready for the open road.

P9500 Sport Luggage Rack; Chrome
P9500-002 Sport Luggage Rack; Black

SIZE

Length: 14.00" (35.5cm)

Width: 07.25" (18.4cm)

MATERIAL



HARDWARE

All mounting hardware included



P9500-002



The **P9500 Solo Rack** includes quality stainless steel fasteners so that your luggage rack looks great – even if you don't pack anything on it.

Paladin® QuickSet™ Backrest and Luggage Rack

Convert your bike from a 2-up tourer to a solo boulevard cruiser in under 5 seconds, with no tools!

National Cycle's **Paladin® QuickSet™ Backrest** uses an innovative, key-lockable mounting system that's designed for an optimal fit on each specific make and model. All moving components are made from stainless steel for years of reliable, smooth operation, and all visible metal components are either stainless steel or finished in bright, show-quality chrome.

After unlocking, just lift the levers on the bottom of the backrest side plates and pull up on the backrest to remove it. Now that's easy!

The Paladin Backrest (sideplates with lock, sissy bar and pad), Luggage Rack, and QuickSet™ Mount Kits are sold separately.

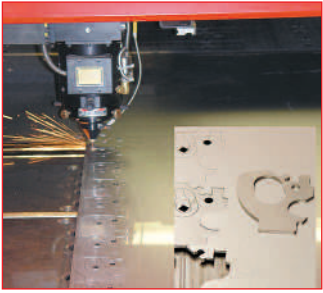

Engineered and precision laser cut, the stainless steel Paladin® and QuickSet™ components are durable and long lasting.



Unlock and lift. It's that easy!



Mounting spools keep a low profile when Paladin assembly is off the bike.



Paladin® QuickSet™ Backrest and Luggage Rack

Paladin® QuickSet™ Mount Kit

Create your system by starting with a QuickSet Removable Mount Kit, the only key lock mount that allows the rider to remove and install the backrest and luggage rack in seconds.

MATERIAL



HARDWARE



All mounting hardware included



Left/Right Side Plates



Left/Right Mounting Spools

Lock it up and leave it on your bike without worry.



Install the QuickSet™ Backrest/Rack assembly onto the front mounting spools...

Paladin® Backrest

This comfortable backrest and pad attaches easily to QuickSet Removable Mounts.

P9800A Backrest (Comfort Pad included)

SIZE (Comfort Pad)

Height: 09.50" (24.1cm)

Width: 07.00" (17.8cm)

MATERIAL



HARDWARE

All mounting hardware included



P9800A



...and simply push down until the rear mounts latch shut. Then turn the key to lock.

Paladin® Luggage Rack

This slick looking rack features hook tabs for cords and straps thoughtfully built in.

P9900 Luggage Rack

SIZE

Length: 09.50" (24.1cm)

Width: 09.50" (24.1cm)

MATERIAL



HARDWARE

All mounting hardware included



P9900



Add a set of Cruiseline™ Saddlebags (additional hardware required) and away you go.

Paladin® Highway Bars

P4010

From bike to bike, considerations such as floorboards, foot controls and cornering clearances are just a few of the details why, model to model, **Paladin® Highway Bars** are designed specifically to your bike.

The thick wall 1.25" tubing is heavily chrome plated to National Cycle's industry leading standards. Paladin Highway Bars are perfect for clamp-on highway pegs. And, in the event of a bike tip over, they may help protect the bike's finish and components.



P4003



P4008



P4009



Every Paladin Highway Bar is checked on its motorcycle for proper cornering clearance.

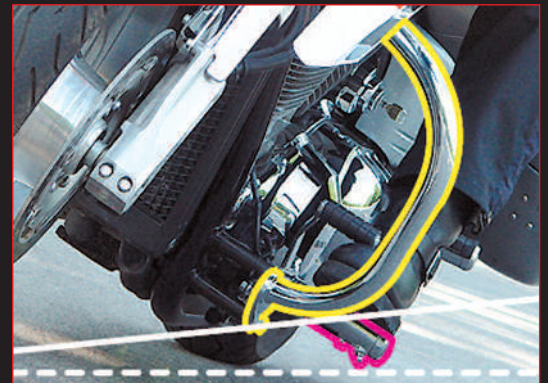

Paladin® Highway Bars

P4011

New Paladin Highway Bars are constantly in development for popular metric cruisers. For the latest applications, check our web site or call your National Cycle dealer.

SIZE

Custom fit for each motorcycle application.

MATERIAL



HARDWARE

All mounting hardware included



P4105



P4012



P4306



Most aftermarket highway pegs with 1.25" clamps can be mounted to the Paladin Highway Bars.

Peacemakers® Variable Volume Exhaust Systems

N41414

National Cycle's **Peacemakers® Exhausts** delivers a sound-adjustable exhaust with outstanding performance. Our electrically operated **Diverter Valve** technology lets you enjoy the deep rumble of an aftermarket exhaust while still exercising social responsibility when riding in populated areas. Patent #7380638.

- You control the sound level – Peacemakers exhausts adjust **while you ride** with a convenient electric switch at the left handlebar grip
- The **Linear Actuator Motor** mounts on the frame downtube and is finished in chrome for good looks
- **Large 4" diameter** mufflers have a show quality chrome finish
- **Broad (12 decibel) change** in sound volume from quiet to loud
- Muffler end cap design allows rotation of the exhaust tips to suit your style preferences
- Snub Nose™ end cap style is optional



QUIET! When You Need It... LOUD When You Want It!™

Peacemakers® Exhausts are direct replacements for the stock mufflers and use the existing stock muffler mounting hardware. The Linear Actuator Motor mounts on the right front frame downtube.

Available for most Harley-Davidson® FLH, FLS, FXS, FXD and XL models, as well as for large-displacement Honda® and Yamaha® v-twin cruisers.

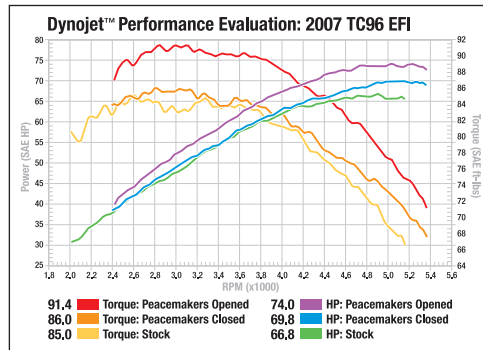

Shown with optional Snub Nose™ Exhaust Tips

N41301

Watch the Peacemakers Exhausts video demo on our web site and hear the difference!

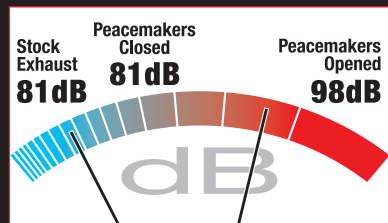

Sound Performance Evaluation

Measured on a stock Yamaha XV1600 Road Star® with a high flow air filter kit at 2400RPM with ANSI dB(C) weighting.



N41902
N41903

Optional Snub Nose™ end caps are available to replace the original Slash Cut end caps.

Patent #7380638

National Cycle Shield Wash™ Cleaner

National Cycle's N1401-01 **Shield Wash™** is mild enough to use often and can be easily carried on your bike.

Our kit includes an 8-oz. refill bottle of Shield Wash, a 1-oz. travel bottle, and a small high quality microfiber cloth. It's everything you need to keep your windshield sparkling clean!

When cleaning your shield, use a soft, clean cloth. Don't rub sharp debris back into your shield. For large shields, spray the top section and work the cloth in a circular motion.

When you're washing your bike or taking layers of dirt off your shield, you can always fall back on a mild dish detergent with lots of water if you don't have our Shield Wash on hand. Be sure to use a soft cloth that's free of debris.

N1401-01



National Cycle RainZip® Rain Repellent

To keep your windshield clearer in rainy weather, National Cycle developed N1410-01 **RainZip®**, a specially formulated rain repellent treatment for National Cycle's Quantum® Hardcoated Polycarbonate Windshields (VStream®, Wave®, SwitchBlade®, Spartan® or Heavy Duty™).

It's also very effective on other polycarbonate windshields, helmet faceshields, and goggles.

RainZip is hydrophobic. When rain accumulates on your windshield, RainZip will cause it to quickly bead up and blow away, even at speeds of only 35MPH.

RainZip will give you a clearer view of the road ahead... especially when it's wet!

Available in a 3-oz. size with special application cloths. This is enough for two large windshield applications, each lasting 3-4 months.



N1410-01



Watch our online video and learn how to use National Cycle's Shield Wash™ and RainZip® on your motorcycle windshield... and then see a demonstration of how well it works!

RainZip's effectiveness is measured by contact angle. If the angle is greater than 90° it is determined to be nonwetting.

All measurements taken on National Cycle's own Tantec® Contact Angle Meter.

	104°	59°	
104°	Quantum Hardcoated Polycarbonate + RainZip		
102°	FMR Hardcoated Polycarbonate + RainZip		
88°	Quantum Hardcoated Polycarbonate		
78°	FMR Hardcoated Polycarbonate		
59°	Acrylic		



GLADIATOR®

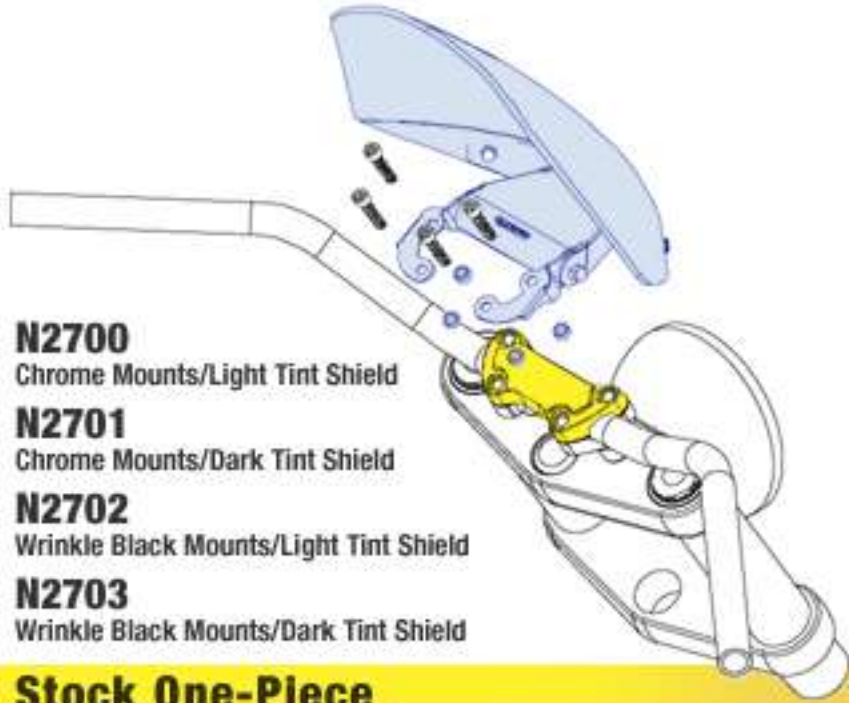

- N2700**
Chrome Mounts/Light Tint Shield
- N2701**
Chrome Mounts/Dark Tint Shield
- N2702**
Wrinkle Black Mounts/Light Tint Shield
- N2703**
Wrinkle Black Mounts/Dark Tint Shield

Stock One-Piece Top Clamp Mount

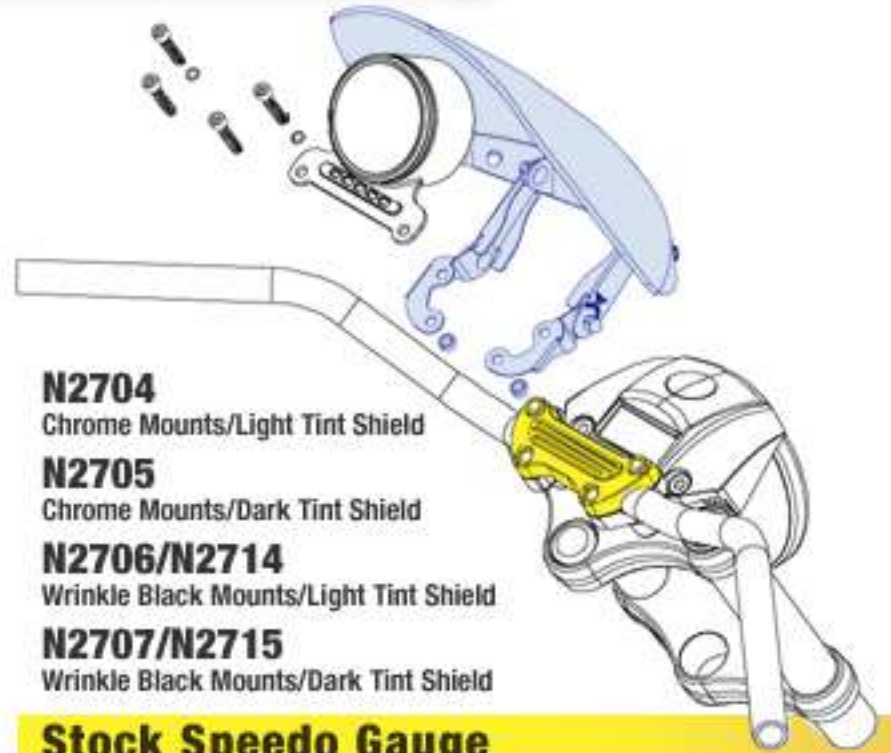

- N2704**
Chrome Mounts/Light Tint Shield
- N2705**
Chrome Mounts/Dark Tint Shield
- N2706/N2714**
Wrinkle Black Mounts/Light Tint Shield
- N2707/N2715**
Wrinkle Black Mounts/Dark Tint Shield

Stock Speed Gauge Top Clamp Mount

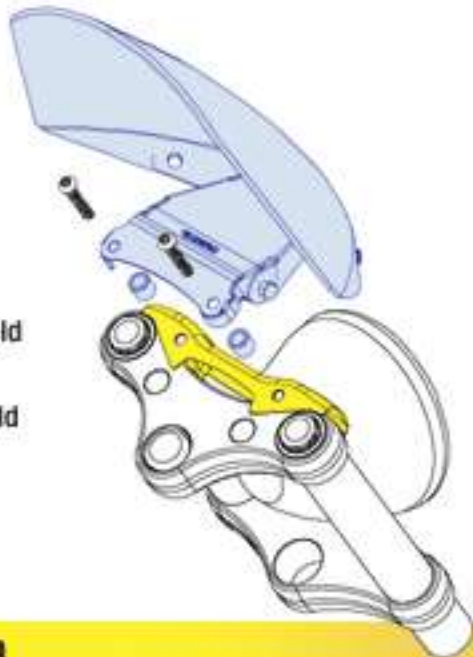

- N2708**
Chrome Mounts/Light Tint Shield
- N2709**
Chrome Mounts/Dark Tint Shield

Stock XL Custom Top Tree Mount

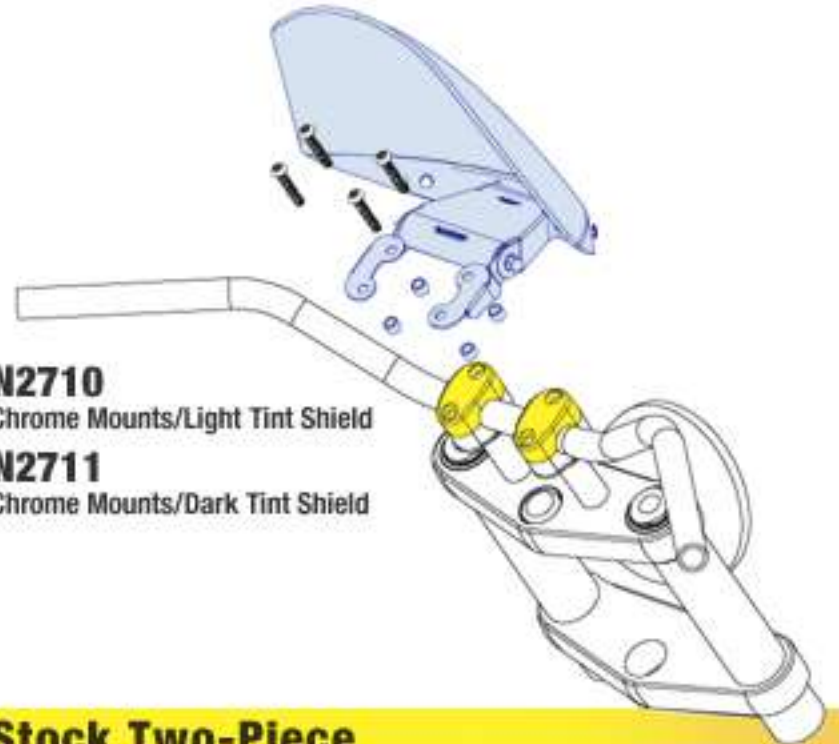

- N2710**
Chrome Mounts/Light Tint Shield
- N2711**
Chrome Mounts/Dark Tint Shield

Stock Two-Piece Top Clamp Mount

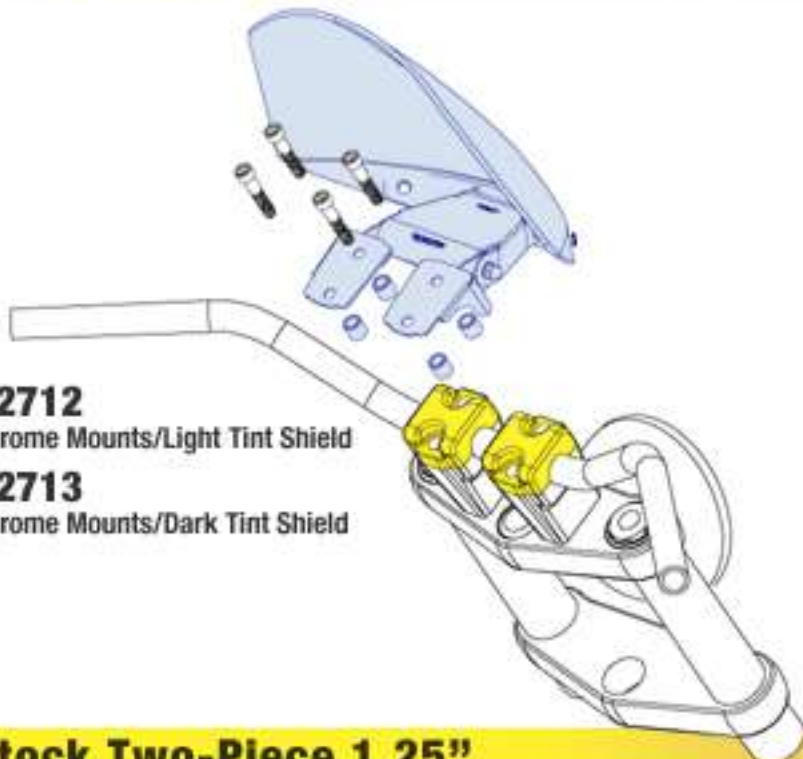

- N2712**
Chrome Mounts/Light Tint Shield
- N2713**
Chrome Mounts/Dark Tint Shield

Stock Two-Piece 1.25" Top Clamp Mount

Verify your handlebar mount style and upper triple tree type before ordering. Call our Customer Service at 877-WSCREEN (877-972-7336) if you aren't sure and we'll be glad to help you.



since 1937
national cycle®



The New **HERITAGE LINE** of Beaded Heavy Duty™ Windshields from National Cycle

Heritage and Classic Style are **BACK IN STOCK** at National Cycle!

The Long-Awaited Return of Red and Blue Beaded Heavy Duty™ Windshields and Separate Components has Arrived!

Complete Windshields

The National Cycle 5-bolt pattern Beaded Heavy Duty™ Windshield is an authentic three-piece beaded construction manufactured with modern, premium quality materials.

The complete windshield is available in polycarbonate with a clear top and your choice of Clear, Red, Blue or Black bottom section, and Early FL-Style or Standard Round adjustable middle window.

Outer frame hardware is bright chrome plated steel and internal hardware is non-glare zinc finish.

Windshield Mount Kits are available for an extremely wide range of makes and models, from legacy applications over half a century old to today's newest domestic and import cruisers.

Separate Components

Tops, bottoms and adjustable middle windows are sold separately for National Cycle 5-bolt pattern Beaded Heavy Duty™ Windshields (*below*) and for OEM 7-bolt pattern beaded windshields (*right*).



Our 7-bolt pattern components (Top Section, Lower Section and Early-FL-Style Adjustable Middle Window) assembled into an OEM 7-bolt pattern frame.



1987-17 Harley-Davidson® FLSTC Heritage Softail™ Classic with N2232

National Cycle complete 5-bolt pattern Beaded Heavy Duty™ Windshields



N2233 on a 1987-17 Harley-Davidson® FLSTC Heritage Softail™ Classic



N2233 on a 1985-97 Honda® VT1100 Shadow

See back of this flyer for windshield and component part numbers and MSRP pricing.



MADE IN U.S.A.



The New HERITAGE LINE of Beaded Heavy Duty™ Windshields from National Cycle

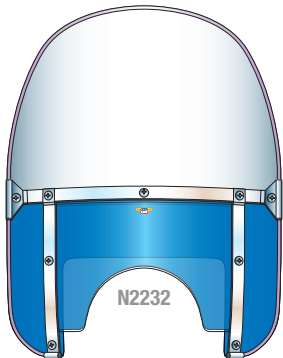
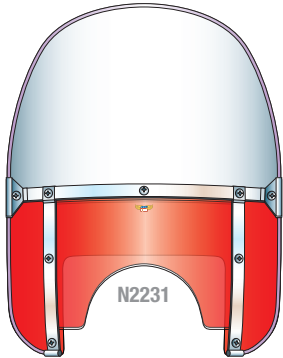
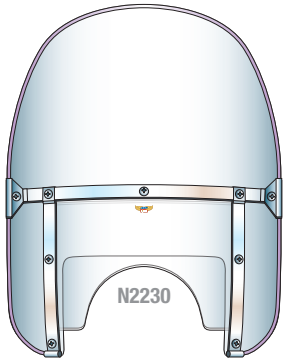

MSRP

National Cycle Beaded Heavy Duty™ Windshields, Complete; 5-Bolt Pattern; Standard Round Adjustable Middle Window

- N2230 Beaded Heavy Duty Windshield; Clear
- N2231 Beaded Heavy Duty Windshield; Red
- N2232 Beaded Heavy Duty Windshield; Blue
- N2233 Beaded Heavy Duty Windshield; Black

National Cycle Beaded Heavy Duty™ Windshields, Complete; 5-Bolt Pattern; Early FL-Style Notched Adjustable Middle Window

- N2234 Beaded Heavy Duty Windshield; Black
- N2235 Beaded Heavy Duty Windshield; Clear
- N2236 Beaded Heavy Duty Windshield; Red
- N2237 Beaded Heavy Duty Windshield; Blue

Beaded Components: For National Cycle 5-Bolt Pattern Hardware

Top Sections

- 20000 Clear Standard Rounded Top
- 20001 Clear Pointed Top for Period-Correct Looks

Bottom Sections

- 22000 Bottom Section; Clear
- 22001 Bottom Section; Red
- 22002 Bottom Section; Blue
- 22003 Bottom Section; Black

Beaded Components: For OEM 7-Bolt Pattern Hardware

Top Sections

- 20002 Clear Standard Rounded Top

Bottom Sections

- 22004 OEM Replacement; Clear
- 22005 OEM Replacement; Red
- 22006 OEM Replacement; Blue
- 22007 OEM Replacement; Black

Adjustable Lower Windows: For 5-Bolt or OEM 7-Bolt Pattern Hardware

1960-84 FL-Style Notched Windows

- 23010 Lower Window; Clear
- 23011 Lower Window; Red
- 23012 Lower Window; Blue
- 23013 Lower Window; Black

1949-59 FL-Style Windows

- 23015 Lower Window; Clear
- 23016 Lower Window; Red
- 23017 Lower Window; Blue
- 23018 Lower Window; Black

Standard Round Windows

- 23020 Lower Window; Clear
- 23021 Lower Window; Red
- 23022 Lower Window; Blue
- 23023 Lower Window; Black

1977-93 FLHS-Style Round Windows

- 23030 Lower Window; Clear
- 23031 Lower Window; Red
- 23032 Lower Window; Blue
- 23033 Lower Window; Black

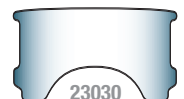
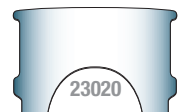
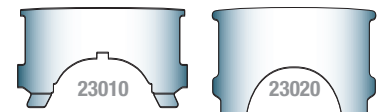
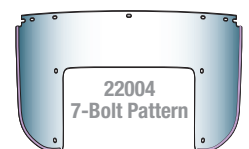
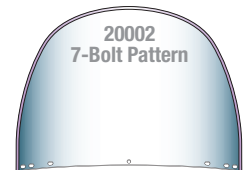
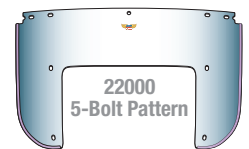
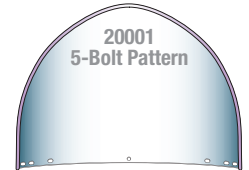
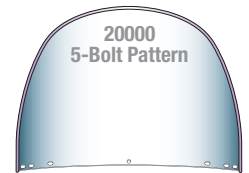

MADE IN U.S.A.





NATIONAL CYCLE PRODUCTS FOR INDIAN® SCOUT MOTORCYCLES



SWITCHBLADE® QUICK RELEASE WINDSHIELDS WITH QUANTUM® HARDCOATED POLYCARBONATE

The largest of the four shields, the **SwitchBlade® 2-Up®** offers maximum protection from the wind and weather for you and your riding partner. The 2-Up gives your Scout serious touring bike performance at a fraction of the price of the upscale machines.

The **SwitchBlade® Chopped™** is a cut-down version of the popular 2-Up. The recontoured top is 4.8" shorter and the trimmed bottom profile is narrower. Get all the protection you need with the slick looks you want!

The smaller screen of the **SwitchBlade® Shorty®** is an ideal choice for a rider who generally does not put long hours in the saddle. Short in size but long on looks and quality features, the Shorty keeps wind blast at bay while preserving the "wind in your face" motorcycling experience.

Designed for maximum attitude, the minimal profile of the **SwitchBlade® Deflector™** is a stylish addition to your Scout. National Cycle's **RakeAdjust™** feature allows you to quickly and easily change the screen angle, transforming the SwitchBlade Deflector from a boulevard cruiser to a functional bug buster – or anywhere in between.



Superior Scratch Resistance!

30X more scratch resistance than typical acrylic windshields is saying a lot! Think of it as 30X more miles per windshield. Even compared to FMR coated polycarbonate, Quantum has **10X better scratch resistance**. That's the kind of performance and strength you need from a motorcycle windshield!



Windshield Measurements

Height is measured from headlight cutout to top of the shield. Width is measured in a straight line across the back of the shield at its widest point.

PART NO.	PART NO.	PART NO.	PART NO.	PART NO.	PART NO.	PART NO.
N21109	N21409	N21410	N21709	N21710	N21901	N21902
2-Up	Chopped	Chopped	Shorty	Shorty	Deflector	Deflector
Clear	Clear	Light Tint	Clear	Light Tint	Clear	Light Tint

	Height	Width
2-Up	20.00"	23.00"
Chopped	15.20"	22.30"
Shorty	13.00"	18.75"
Deflector	12.00"	14.00"

Hardware **KIT-Q344-001** or **KIT-Q344-002** required for installation.

SWITCHBLADE® QUICK RELEASE MOUNT KIT

One Mount Kit... Any Quick Release Windshield!

The SwitchBlade® Quick Release Mounting System gives you the flexibility to mount any of four styles of SwitchBlade Windshields – or Spartan® or WaveQR® – to the Indian® Scout with ONE Mount Kit.

On and Off in Less Than Five Seconds... Without Tools!

This fork-mount hardware system secures your windshield with bulldog tenacity but looks attractive when the shield is off. Innovative stainless steel cushion wheel spools turn and flex, allowing the shield to lock into place with a reassuring "pop".

PART NO.	PART NO.
KIT-Q344-001	KIT-Q344-002
SwitchBlade Mount Kit Brilliant Chrome	SwitchBlade Mount Kit Powdercoated Black





NATIONAL CYCLE PRODUCTS FOR INDIAN® SCOUT MOTORCYCLES



NEW!

SPARTAN® QUICK RELEASE WINDSHIELDS WITH QUANTUM® HARDCOATED POLYCARBONATE

You won't find a better quality touring-sized windshield at such a great price! The **Spartan® Windshield** has a stainless steel frame finished in a stealthy black powdercoat and looks perfect on the Scout.

This full-size **Quantum® hardcoated polycarbonate** windshield comes in two heights and mounts to our tried-and-true **SwitchBlade® Quick Release Mount Kit**, the same kit that mounts our **SwitchBlade®** and **Wave QR®**.



Superior Scratch Resistance!

30X more scratch resistance than typical acrylic windshields is saying a lot! Think of it as 30X more miles per windshield. Even compared to FMR coated polycarbonate, Quantum has **10X better scratch resistance**. That's the kind of performance and strength you need from a motorcycle windshield!



Windshield Measurements

Height is measured from headlight cutout to top of the shield. Width is measured in a straight line across the back of the shield at its widest point.

	Height	Width
N21203	18.50"	18.00"
N21303	16.25"	18.30"

PART NO.	PART NO.
N21203	N21303
Tall	Mid Size
Clear	Clear

Hardware KIT-Q344-001 or KIT-Q344-002 required for installation.



NEW!

WAVE QR® QUICK RELEASE FAIRINGS WITH RAKE ADJUST™

Have the hottest looking bike around with the **Wave QR®** – the fairing that defines performance on the edge. Whether it's slammed back or raked forward, the Wave QR's sculpted body captures the free spirit of your Scout motorcycle.

The Wave QR® Fairing is made from **FMR hardcoated polycarbonate**, the same tough, durable material we introduced to the motorcycle industry in 1975. Ride it fast and ride it hard – it can take the abuse!

The Wave QR® is a quick release fairing... it's removable in just seconds, without tools, thanks to National Cycle's **SwitchBlade® Quick Release Mount Kit**.

And, it's rake adjustable for custom-tuned performance and the looks you want!

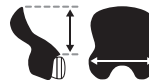

Windshield Measurements

Wave QR Fairings are measured from the headlight cutout in a vertical line level to the top of the shield in the fully raked forward position. Width is measured in a straight line across the back of the shield at its widest point.

	Height	Width
N21605	10.50"	18.00"

PART NO.
N21605
Fairing
Dark Tint

Hardware KIT-Q344-001 or KIT-Q344-002 required for installation.

IMPACT STRENGTH

200 Hardcoated Polycarbonate

20 High Impact Acrylic

10 Acrylic

CRACK RESISTANCE

35.0 All measurements in Foot-Pounds

8.0

1.5



NATIONAL CYCLE PRODUCTS FOR INDIAN® SCOUT MOTORCYCLES



Custom Heavy Duty

Low Boy Heavy Duty

Ranger Heavy Duty

HEAVY DUTY™ WINDSHIELDS WITH QUANTUM® HARDCOATED POLYCARBONATE

These **Heavy Duty™ Windshields** feature the same quality materials and construction as the SwitchBlade® and Spartan® Windshields, but use a fixed fork mount kit rather than a quick release kit.

The **Custom Heavy Duty™** is one of our most popular windshields and offers plenty of height with a slim profile for riders who want long distance touring comfort.

The **Low Boy Heavy Duty™** is the cut down version of the Custom. It is the perfect choice for riders sitting low in the saddle or for the rider who likes a low screen.

The **Ranger Heavy Duty™** cuts the slim profile to its limits for the rider who wants just a small shield. The Ranger has a performance-oriented drag-style look.



Superior Scratch Resistance!

30X more scratch resistance than typical acrylic windshields is saying a lot! Think of it as 30X more miles per windshield. Even compared to FMR coated polycarbonate, Quantum has **10X better scratch resistance**. That's the kind of performance and strength you need from a motorcycle windshield!



Windshield Measurements

Height is measured from headlight cutout to top of shield. Width is measured in a straight line across the back of the shield at its widest point.

Heavy Duty Windshields have an adjustable lower window, so the headlight cutout varies depending on individual rider adjustments.

	Height	Width
Custom	19.00-21.00"	18.75"
Low Boy	14.25-16.00"	18.75"
Ranger	13.75-16.25"	16.50"

PART NO.	PART NO.	PART NO.	PART NO.
N2220	N2221	N2290	KIT-CIN
Custom Clear	Low Boy Clear	Ranger Clear	Heavy Duty Mount Kit Chromed Steel



NATIONAL CYCLE HAND DEFLECTORS

National Cycle **Hand Deflectors** are an easy-to-install, economical solution for keeping your hands warm and dry. Coupled with a windshield, Hand Deflectors protect your entire upper body from cold wind and rain. They also make heated grips work more effectively.

Hand Deflectors mount easily and securely to the Scout's mirror mounts, yet allow plenty of room for lever movement when wearing heavy gloves. They make a windshield function more like a fairing.

PART NO.
N5521
Hand Deflectors; Pair; Light Tint

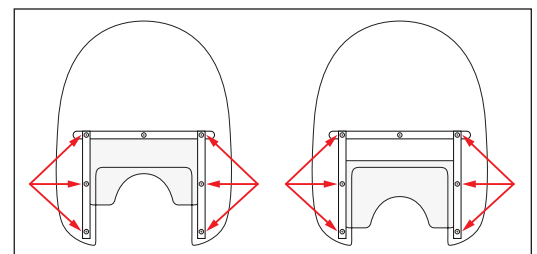

To install the Heavy Duty Windshield to the Indian Scout, the adjustable window needs to be in the lowest position. Loosen the screws indicated, lower the window, and retighten the screws.





NATIONAL CYCLE PRODUCTS FOR INDIAN® SCOUT MOTORCYCLES



NEW! Deflector Screen™

Street Shield™ **NEW!**



INTRODUCING THE NEW DEFLECTOR SCREEN™ AND STREET SHIELD™ WITH QUANTUM® HARDCOATED POLYCARBONATE

Our original 2-point QuickSet™ mount Deflector Screen™ was first introduced in 1980 and became an instant hit with riders everywhere. It defined the term “universal windshield.” We then followed up with the Street Shield™, a larger screen with a 4-point QuickSet mounting system.

Now there's a better reason to stock these popular windshields for your customers: They've been upgraded from High Impact Acrylic to National Cycle's exclusive Quantum® hardcoated polycarbonate – the state-of-the-art in scratch resistance – but with no price increase!

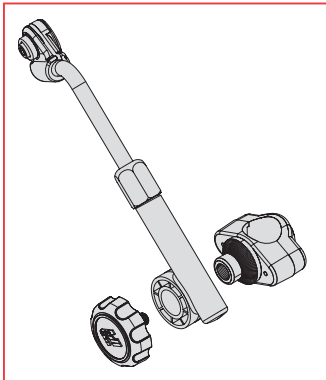

QuickSet™ for Deflector Screen™

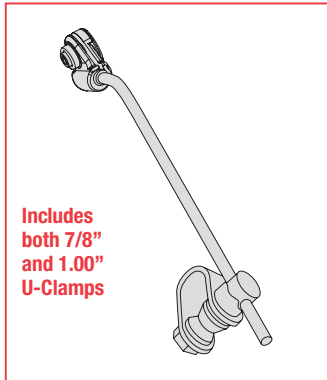

U-Clamp for Deflector Screen™

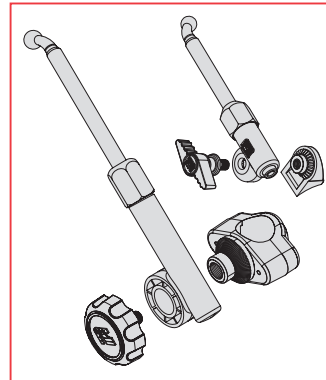

QuickSet™ for Street Shield™

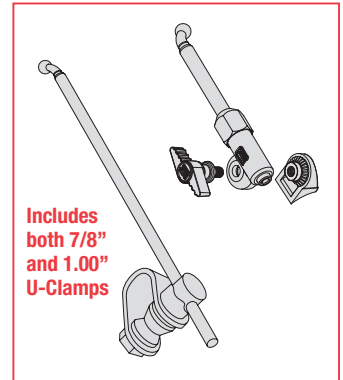

U-Clamp for Street Shield™

NATIONAL CYCLE DEFLECTOR SCREEN™

Our Deflector Screen™ is the most copied windshield worldwide. But only ours offers the no-tool Rake Adjust™ hardware. This simple rake angle adjustment feature has made this small windshield popular among motorcyclists everywhere.

The N25030 Deflector Screen attaches to the handlebars with our U-Clamp and Eyebolt system. The N25042 Deflector Screen attaches to the handlebars with our QuickSet™ system for easy on-and-off convenience. Both mount kits fit 1.00" (25mm) handlebars.

PART NO.	PART NO.
N25042	N25030
QuickSet™ Mount	U-Clamp Mount
Clear	Clear

NATIONAL CYCLE STREET SHIELD™

Our Street Shield™ is a great choice for riders who need more wind protection than our Deflector Screen offers. Its No-Hole Ballssocket™ mounts provide a good range of adjustment, and the shallow headlight cutout fits the Scout perfectly.

The Street Shield features a solid 4-point mount that attaches to the handlebars and upper fork tubes. The N25000 attaches to the handlebars with our U-clamp and Eyebolt system, while the N25012 attaches to the handlebars with our QuickSet™ system for easy on-and-off convenience. Both mount kits fit 1.00" (25mm) handlebars.

PART NO.	PART NO.
N25012	N25000
QuickSet™ Mount	U-Clamp Mount
Clear	Clear

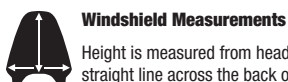

Windshield Measurements

Height is measured from headlight cutout to top of the shield. Width is measured in a straight line across the back of the shield at its widest point.

	Height	Width
Deflector Screen	14.00"	15.00"
Street Shield	17.00"	16.00"



NATIONAL CYCLE PRODUCTS FOR INDIAN® SCOUT MOTORCYCLES



NATIONAL CYCLE FLYSCREEN®

Add some real sizzle to your Scout! National Cycle's **Flyscreen®** will give your Scout a dragster look – whether you're headed for the quarter-mile strip or the local boulevard.

The clean appearance is accented with a chrome front trim plate. A quality fork-mount system with countersunk screws offers an adjustable custom fit.

Available in Light Tint High Impact Acrylic or Dark Tint FMR Hardcoated Polycarbonate. All mounting hardware is included.



Windshield Measurements

Height is measured from headlight cutout to top of the shield. Width is measured in a straight line across the back of the shield at its widest point.

	Height	Width
Flyscreen	08.50"	09.25"

PART NO.	PART NO.
N2530	N2531
26% Light Tint	95% Dark Tint



NATIONAL CYCLE CAST FENDER TIPS

Create the perfect fender treatment for your Indian® Scout! The new Scout deserved a unique fender tip design – different from our traditional styles – so that's what we gave it.

These **Cast Fender Tips** are easy to install and come with countersunk outside screws (requires drilling) for the cleanest possible appearance.

This hallmark product of National Cycle has been painstakingly refined for modern cruisers. By casting the product, the shape and high crown details that distinguish these tips really stand out. These are not ordinary fender tips. They have a show bike polish with a jewel-quality chrome finish.



PART NO.	PART NO.
N7048	N7049
Cast Front Fender Tips; 2-Piece Set Chromed	Cast Rear Fender Tip 1-Piece Set Chromed



NATIONAL CYCLE PRODUCTS FOR INDIAN® SCOUT MOTORCYCLES

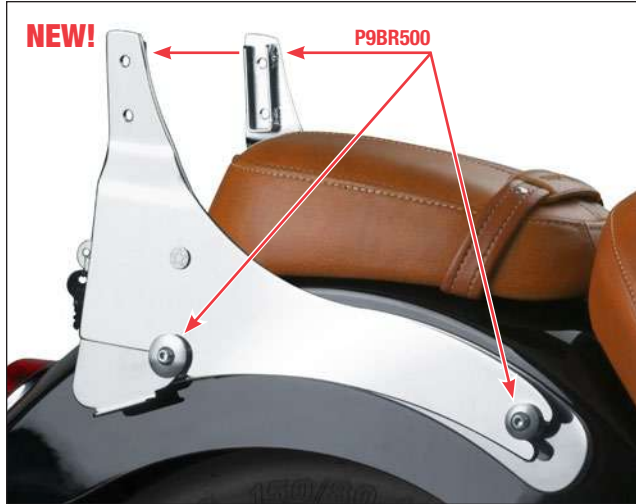

PALADIN® QUICKSET™ MOUNT KIT, BACKREST AND LUGGAGE RACK

Convert your Scout from solo boulevard cruiser to 2-up tourer in under 5 seconds, with no tools!

National Cycle's **Paladin® QuickSet™ Mount Kit** uses an innovative, key-lockable mounting system that's designed for an optimal fit on each specific make and model. All moving components are made from stainless steel for years of reliable, smooth operation, and all visible metal components are either stainless steel or finished in bright, show-quality chrome.

After unlocking, just lift the levers on the bottom of the backrest side plates and pull up on the backrest to remove it. Now that's easy!

PART NO.	PART NO.	PART NO.
P9BR500	P9800A	P9900
QuickSet™ Mount Kit	Backrest with Pad	Luggage Rack



	Height	Width		Length	Width
Backrest Pad	08.50"	07.00"	Luggage Rack	09.50"	09.50"



FENDER-MOUNT SOLO LUGGAGE RACK

The solo Scout rider gets something special that we've never done before – a cool fender-mounted **Solo Luggage Rack** that looks like it's fresh off of a 1942 Indian Sport Scout.

Simply remove the passenger pillion and use the same OEM hardware to mount the rack. It's a quick and simple job that pays back big style points – as well as added luggage carrying capacity.

Available in Brilliant Chrome or Powdercoated Gloss Black.

PART NO.	PART NO.
P9500-001	P9500-002
Solo Rack Chrome	Solo Rack Gloss Black

	Length	Width
Solo Rack	14.00"	07.25"



NATIONAL CYCLE PRODUCTS FOR INDIAN® SCOUT MOTORCYCLES



NEW!



CRUISELINER™ MOUNT KIT AND QUICK RELEASE HARD SADDLEBAGS

Every Scout deserves a great pair of lockable, quick-release, hard saddlebags – like our popular **Cruiseline™ Saddlebags!** To give Scout riders this option, we designed and engineered a special **Saddlebag Mount Kit** just for the Scout.

Cruiseline saddlebags open easily with a “thumb push” lock that flips the lid forward for easy access to items. The interior walls, lid, and seal are designed to keep the contents safe and dry. One key locks both saddlebag lids securely.

Quick-detach quarter-turn fasteners are located securely inside the bag for “no-tool” quick removal of the saddlebags from the frames.

Cruiseline Saddlebags are molded from an extremely durable polymer blend and are pre-painted gloss black.

PART NO.	PART NO.	PART NO.
KIT-SB500	N1101	N1350
Saddlebag Mounts Gloss Black	Cruiseline™ Saddlebags Gloss Black	Cruiseline Inner Duffels Black



	Length	Height	Width	Capacity
Saddlebag; Each	24.50"	14.00"	07.50"	22 liters



CRUISELINER™ INNER DUFFEL BAGS

One of the most practical accessories you can add to your Scout is a set of Cruiseline™ Saddlebags. Now practicality gets practically perfect with our N1350 **Inner Duffels for Cruiseline Saddlebags.**

The inner duffel is stitched to shape so it fits easily into the compartment of the hard bags. The generous size conforms to the inside cavity with room to spare.

This well-constructed duffel is made from 600 denier polyester with a waterproof coating. A two-way zipper allows easy access in and out of the bag.

These features, along with the sturdy nylon web handles, make it easy to remove and carry your cargo without removing the saddlebags from the bike.



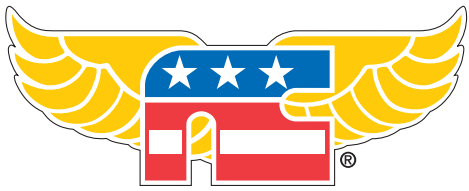

national cycle



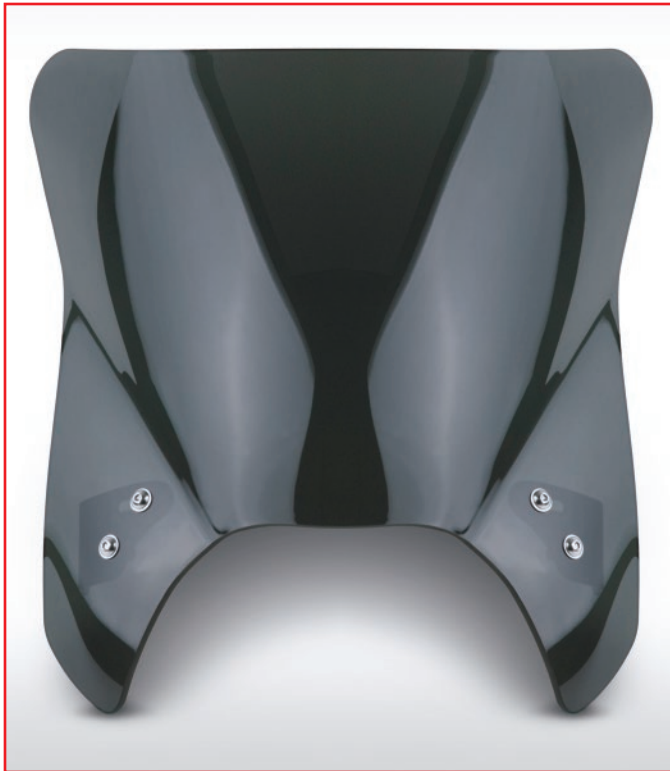

Mohawk – The start of a new classic



Continuing the minimalist, sporty tradition of our famous Flyscreen®, the new Mohawk™ features a taller and wider size with a special 'V' profile for added wind management. As with our Flyscreen, the versatile Mohawk is adaptable to many motorcycles.

- Thick 4.5mm dark tint hardcoated polycarbonate for durability and long lasting good looks
- Backed by National Cycle's 3-Year Unbreakable Warranty
- State-of-the-art manufacturing; smooth radius edges; superb forming, and sharp optical quality
- New 51mm diameter Fork Clamp added – eliminates excessive fork gaskets
- Patented brackets are engineered for fork width adjustment from 8.5"-11.0" (21.6 - 28.0cm) spacing
- High strength, lightweight, machined aluminum brackets have the look of custom billet



Straight Arm Fork Tube Mounts



Curved Arm Fork Tube Mounts



Flat Bracket Headlight Mounts

MOHAWK

PART NO.

MATERIAL / FINISH / MOUNTING HARDWARE

FLYSCREEN

CROSS REFERENCE

FORK SIZE / MOUNT TYPE

N2831-001	Dark Tint Hardcoated Poly; Chrome Straight Arm Hardware	N2531	Fits up to 43mm O.D. Fork Tubes
N2831-002	Dark Tint Hardcoated Poly; Black Straight Arm Hardware	N2531-002	Fits up to 43mm O.D. Fork Tubes
N2833-001	Dark Tint Hardcoated Poly; Chrome Curved Arm Hardware	N2533	Fits up to 43mm O.D. Fork Tubes
N2833-002	Dark Tint Hardcoated Poly; Black Curved Arm Hardware	N2533-002	Fits up to 43mm O.D. Fork Tubes
N2839-001	Dark Tint Hardcoated Poly; Chrome Straight Arm Hardware	N2555-001	Fits 44-51mm O.D. Fork Tubes
N2839-002	Dark Tint Hardcoated Poly; Black Straight Arm Hardware	N2555-002	Fits 44-51mm O.D. Fork Tubes
N2841-001	Dark Tint Hardcoated Poly; Chrome Curved Arm Hardware	N2557-001	Fits 44-51mm O.D. Fork Tubes
N2841-002	Dark Tint Hardcoated Poly; Black Curved Arm Hardware	N2557-002	Fits 44-51mm O.D. Fork Tubes
N2835-001	Dark Tint Hardcoated Poly; Chrome Straight Arm Hardware	N2535	Fits 52-56mm O.D. Fork Tubes
N2835-002	Dark Tint Hardcoated Poly; Black Straight Arm Hardware	N2535-002	Fits 52-56mm O.D. Fork Tubes
N2837-001	Dark Tint Hardcoated Poly; Chrome Curved Arm Hardware	N2537	Fits 52-56mm O.D. Fork Tubes
N2837-002	Dark Tint Hardcoated Poly; Black Curved Arm Hardware	N2537-002	Fits 52-56mm O.D. Fork Tubes
N2844-001	Dark 95% Tint Polycarbonate; Chrome Flat Bracket Hardware	N2544	Headlight Mount
N2844-002	Dark 95% Tint Polycarbonate; Black Flat Bracket Hardware	N2544-002	Headlight Mount

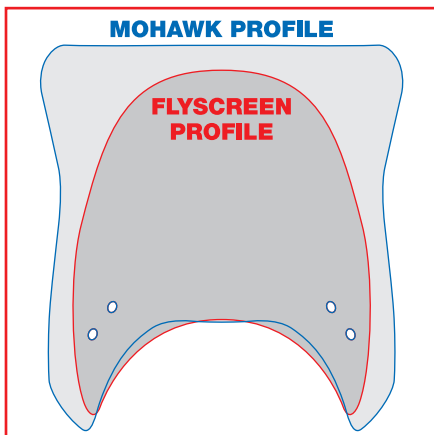

Comparative sizes of the new **MOHAWK** and the original **FLYSCREEN**.

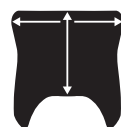

Headlight Cutout to Top of Screen:
09.25" (23.5cm)

Width Across Back at Widest Point:
11.75" (29.8cm)





THE WORLD'S BEST WINDSHIELDS AND ACCESSORIES SINCE 1937

National Cycle Manufactures Windshields and Accessories for Almost Every Motorcycle Make and Model. Visit Our Web Site to See Our Complete Product Line.



Factory 3-Year Warranty

Our exclusive 3-Year Warranty covers all polycarbonate windscreens and windshields against breakage.



N20058
VStream® Windscreen
2015-Current Honda® Africa Twin
Available in Three Sizes



Z2831-002
Mohawk™ Windshield
Universal Fitment
Available with Black or Chrome Hardware

VSTREAM+® WINDSCREENS



VSTREAM® WINDSCREENS



VSTREAM+® WINDSCREENS



SWITCHBLADE® WINDSHIELDS



SPARTAN® WINDSHIELDS



HAND DEFLECTORS



PALADIN® ACCESSORIES



CRUISELINER™ BAGS



SxS UTV PRODUCTS

F-SERIES™ FAIRINGS

PLEXIFAIRING 3™

FLYSCREEN®

STREET SHIELD™

DEFLECTOR SCREEN™

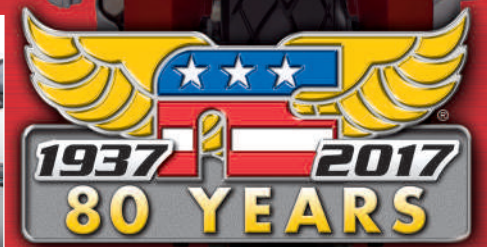



**ACCESSORIES EXCLUSIVELY
FOR BMW® MOTORCYCLES**
BY NATIONAL CYCLE INC.

**WE HAVE 80+ WINDSCREEN OPTIONS
FOR 45+ DIFFERENT MODELS
INCLUDING YOURS:**



ZTechnik 3-Year Warranty
Our exclusive 3-Year Warranty covers all ZTechnik polycarbonate windscreens and windshields against breakage.

**C SERIES G SERIES R SERIES
F SERIES K SERIES S SERIES**



Z2351
VStream® Windscreen
2014-Current R1200RT
Available in Two Sizes



Z2485
VStream® Windscreen
Available in Three Sizes

R1200RS VSTREAM®



R1200R VSTREAM+®



S1000XR VSTREAM®



GS STABLEZER KIT



FAIRING WINGLETS



HEADLIGHT GUARDS



RAKE ADJUST KIT

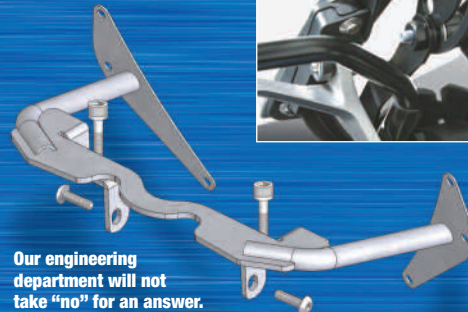

Our engineering department will not take "no" for an answer.

Some models of VStream Windscreens require a custom designed mounting bracket. Our brackets are designed to integrate perfectly with the bike's fit and finish and will not interfere with OEM cables and controls.

When a bracket kit is included, we call this windshield a VStream+.

PLUS:

ENGINE GUARDS



CARBON FIBER TRIM



ACCESSORY MOUNTS



MACHINED ZCAPS



MIRROR EXTENDERS



AND MORE!

MADE IN THE U.S.A.

QUICK RELEASE WITH A NEW LOOK



S P A R T A N®

Shown with N1321 Holdster™



The new **Spartan® Windshield's** stainless steel frame finished in stealth black powdercoat puts this full size windshield offering in a category of its own.

Spartan leads the way in **low cost, Quantum® hard-coated polycarbonate quick release windshields!**

A 16.25" Spartan Windshield and a KIT-Q143 Mount Kit

Top Left: N21201 18.50" Spartan

Top Right: N21202 18.50" Spartan

Lower Right: N21201 18.50" Spartan



WORLDWIDE LEADER IN WINDSHIELD TECHNOLOGY

QUICK RELEASE WITH A NEW LOOK

PRODUCT FEATURES



- Stainless steel with stealth black powdercoat
- Simplified fitments made possible by **parallel slotted tabs** that adjust for different width forks (Patent 6196614)
- Touring size windshields provides good protection in all types of weather and come in **18.50" and 16.25" heights**
- Spartan™ Windshields mount to the tried-and-true **SwitchBlade® Quick Release Mount Kits**
- Rubber grommet suspension with **compression limiters**

PRODUCT SPECIFICATIONS

N21200, N21201, N21202

Height 18.50" (47.0cm) **Width** 18.00" (45.7cm)

Spartan Windshields are measured from the bottom center headlight cutout to the top of the screen, and horizontally at their widest point.



N21300, N21301, N21302

Height 16.25" (41.3cm) **Width** 18.00" (45.7cm)

Spartan Windshields fit a very wide range of XL, FXD, FXS and FLS models. Check our web site for your bike's applications.

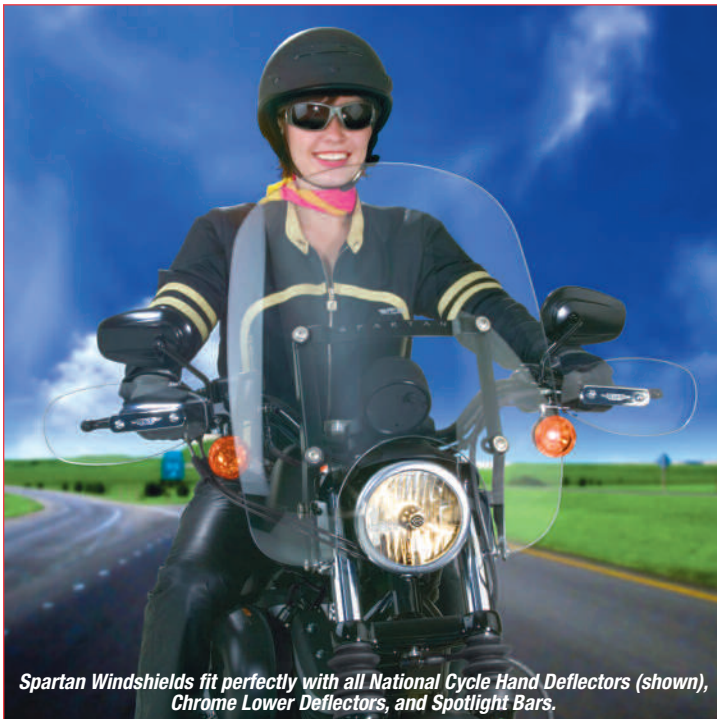

Spartan Windshields fit perfectly with all National Cycle Hand Deflectors (shown), Chrome Lower Deflectors, and Spotlight Bars.



S P A R T A N®

THE BEST MATERIALS

Quantum® hardcoated polycarbonate gives outstanding strength and unbeatable scratch resistance to a National Cycle windscreen.

Polycarbonate Strength

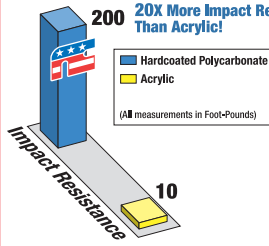

Quantum® Hardcoat

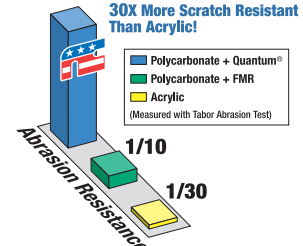

- Quality is evident when you feel the smooth radiused edge and look at the shape of a National Cycle windshield
- Available in 18.50" and 16.25" touring sizes
- 3-Year Warranty against breakage... period!



Think about riding into the sun or at night and not having to look through the glare of fine scratches! That's the Quantum® Difference!



Quantum® is a trademark of National Cycle Inc.

WORLDWIDE LEADER IN WINDSHIELD TECHNOLOGY

**THE WORLD'S BESTSELLING UNIVERSAL WINDSHIELDS
JUST GOT BETTER!**

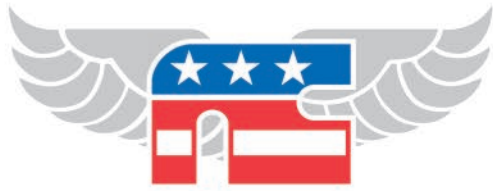

DEFLECTOR SCREEN

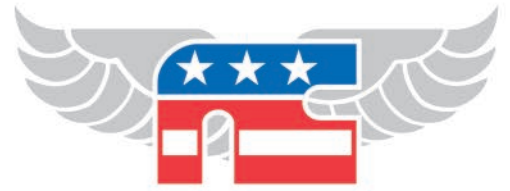

***Street*SHIELD**



**NEW DESIGN!
NEW MATERIAL!
SAME OLD PRICE!**

Cross Reference: New Item Numbers to Discontinued Item Numbers

<u>New Item No.</u>	<u>Description of New Item No.</u>	<u>Supersedes Item No.</u>
Deflector Screen		
N25030	Deflector Screen, Clear, 7/8" (22mm) & 1" (25mm) U-Clamp	N2590-01
N25031	Deflector Screen, Tint, 7/8" (22mm) & 1" (25mm) U-Clamp	N2591-01
N25040	Deflector Screen, Clear, 7/8" (22mm) QuickSet	N2594-01
N25041	Deflector Screen, Tint, 7/8" (22mm) QuickSet	N2595-01
N25042	Deflector Screen, Clear, 1" (25mm) QuickSet	N2594A-01
N25043	Deflector Screen, Tint, 1" (25mm) QuickSet	N2595A-01
N25044	Deflector Screen, Clear, 1.25" (31.75) QuickSet	N2594B-01
N25045	Deflector Screen, Tint, 1.25" (31.75) QuickSet	N2595B-01
Street Shield		
N25000	Street Shield, Clear, 7/8" (22mm) & 1" (25mm) U-Clamp	N2560-01
N25001	Street Shield, Tint, 7/8" (22mm) & 1" (25mm) U-Clamp	N2561-01
N25010	Street Shield, Clear, 7/8" (22mm) QuickSet	N/A
N25011	Street Shield, Tint, 7/8" (22mm) QuickSet	N/A
N25012	Street Shield, Clear, 1" (25mm) QuickSet	N/A
N25013	Street Shield, Tint, 1" (25mm) QuickSet	N/A
N25014	Street Shield, Clear, 1.25" (31.75) QuickSet	N/A
N25015	Street Shield, Tint, 1.25" (31.75) QuickSet	N/A

Deflector Screen



Deflector Screen



Deflector Screen



Street Shield



Street Shield



Street Shield



Introducing the NEW Quantum® Hardcoated Deflector Screen™ and Street Shield™

Our original 2-point QuickSet™ mount Deflector Screen™ was first introduced in 1980 and became an instant hit with riders everywhere. It defined the term “universal windshield.” We then followed up with the Street Shield™, a larger screen with a 4-point QuickSet mounting system.

Now there’s a better reason to stock these popular windshields for your customers: They’ve been upgraded from High Impact Acrylic to National Cycle’s exclusive Quantum® hardcoated polycarbonate – the state-of-the-art in scratch resistance – but with no price increase!



Deflector Screen

Street Shield

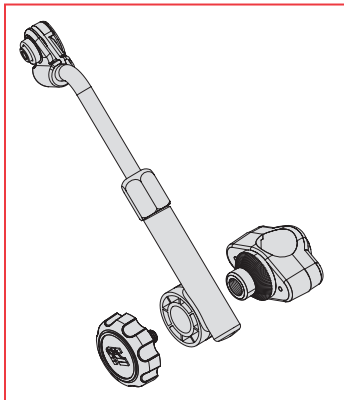

QuickSet™ for Deflector Screen™

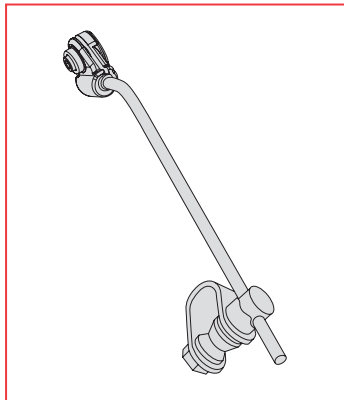

U-Clamp for Deflector Screen™

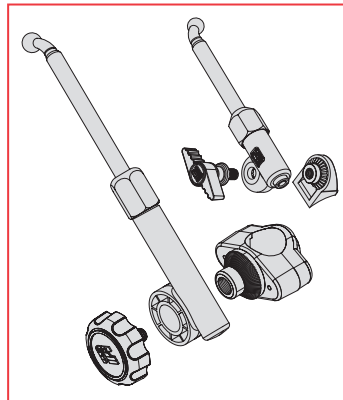

QuickSet™ for Street Shield™

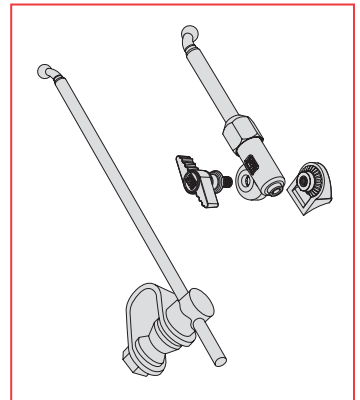

U-Clamp for Street Shield™

NATIONAL CYCLE DEFLECTOR SCREEN™

- Sturdy polycarbonate with Quantum® Hardcoating
- 2-Point QuickSet™ or U-Clamp Mount with RakeAdjust
- Height: 14.00”, an Excellent Compact Screen

QuickSet Mount	Clear	Tint
7/8” handlebars	N25040	N25041
1” handlebars	N25042	N25043
1.25” handlebars	N25044	N25045

NOTE: BAG#047A and BAG#053 needed for non-tubular bars; BAG#053 and BAG#054 needed for mirror mount.

U-Clamp Mount	Clear	Tint
7/8” and 1” handlebars	N25030	N25031

NOTE: BAG#047A and BAG#062 needed for non-tubular bars; BAG#054 and BAG#062 needed for mirror mount.

NATIONAL CYCLE STREET SHIELD™

- Sturdy polycarbonate with Quantum® Hardcoating
- 4-Point QuickSet™ or U-Clamp Mount
- Height: 17.00”, an Excellent Mid-Size Screen

QuickSet Mount	Clear	Tint
7/8” handlebars	N25010	N25011
1” handlebars	N25012	N25013
1.25” handlebars	N25014	N25015

NOTE: BAG#047A and BAG#053 needed for non-tubular bars; BAG#053 and BAG#054 needed for mirror mount.

U-Clamp Mount	Clear	Tint
7/8” and 1” handlebars	N25000	N25001

NOTE: BAG#047A and BAG#062 needed for non-tubular bars; BAG#054 and BAG#062 needed for mirror mount.

QUANTUM INNOVATION IN WINDSCREEN MATERIALS

What are the Benefits of Polycarbonate?

Outstanding impact strength! No other thermoplastic comes close to matching the impact strength of polycarbonate, making it the ideal material for motorcycle windshields. It is **20X more impact resistant** than acrylic plastic (Lucite®). You can check the data from the Free Falling Steel Dart Test and the IZOD Notch Test but **real world testimonials**, like the one from a customer who met a ball peen hammer at 75MPH attest to the outstanding impact strength of polycarbonate. So whether it is birds, bugs, stones or hammers, for the serious rider, a strong windshield is very important.

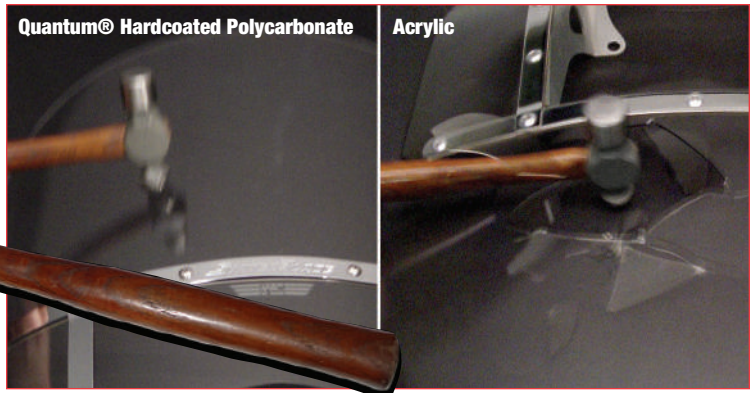

We applied a ball peen hammer at full force to one of our polycarbonate screens (left) and to a competitor's acrylic screen (right). We're professionals – don't try this at home!

Why Hardcoat Windshields?

Many riders agree that strength is an important benefit, but ask, "What affects the transparency of a windshield?" However tough polycarbonate is, it's routinely subjected to surface deterioration from abrasion. **Polycarbonate must be hard-coated to be optically clear enough for use as a motorcycle windshield.**

Introducing Quantum: the World Standard

FMR is a good polycarbonate hardcoating and was the industry standard until National Cycle made a "quantum" improvement in the surface characteristics of motorcycle windshields exposed to years of use and wear.

We start with a polycarbonate sheet, but it is our **exclusive Quantum® hardcoating** that has defined the state-of-the-art in windshield scratch resistance and optical clarity.

What Makes Quantum® Hardcoated Wind-screens Better Than All the Others?



Superior Scratch Resistance

30X more scratch resistance than typical acrylic windcreens is saying a lot! Think of it as 30X more miles per wind-screen. FMR hardcoated polycarbonate is

a big improvement over acrylic, yet Quantum has **10X better scratch resistance** than FMR. That's the kind of performance and strength you need from a motorcycle windshield!



Glare-Free Optics

Think about riding into the sun or at night and not having to look through the glare of fine scratches that eventually show up on your screen. **Quantum coating gives your**

windscreen much better optical definition and clarity, and your windshield will stay that way a lot longer.

Polycarbonate Strength Impact Resistance

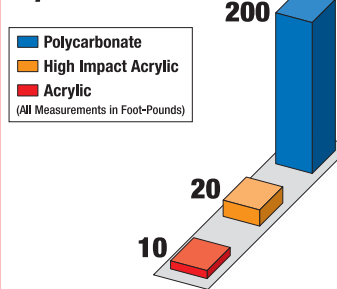

We use a steel wool scratch test to demonstrate the abrasion resistance of Quantum hardcoated polycarbonate (top) against acrylic (bottom).

Polycarbonate vs. Acrylic: YOU Decide!



Watch our video, "Polycarbonate vs. Acrylic: YOU Decide!", and see how our hardcoated polycarbonate windcreens withstand the kind of abuse that reduces typical acrylic windcreens to little pieces!



SPECIAL EDITION FROM NATIONAL CYCLE



National Cycle elevates their popular VStream® Windscreen to a higher level. Introducing the **VStream® Special Edition** for the GL1800! Photos cannot capture the comfort level and touring pleasure you'll enjoy with this windscreen.

This is the **Ultimate Windscreen** for your GL1800, with comfort and performance you'll need to experience to believe.

Top Left:
N20014 VStream® Special Edition for GL1800

Top and Bottom Right:
N20014 in lowered and raised positions



WORLDWIDE LEADER IN WINDSHIELD TECHNOLOGY

SPECIAL EDITION FROM NATIONAL CYCLE

PRODUCT FEATURES



National Cycle's innovative **VStream® Windscreens** gets its name from the unique shape and dimensional contours designed and engineered into the windscreen. The patented "V" shape helps push the turbulent wind out and away from the side of the rider's head, producing a quieter and more comfortable riding experience for both the rider and the passenger.



Quality features include sturdy **6.0mm thick polycarbonate** that reduces vibration and flex common with thinner windshields.

A SECURE FITTING WINDSHIELD

For rock-solid stability at all speeds, we made the Special Edition from **6mm thick polycarbonate**. Our workmanship extends to the smallest detail, like our supplied die-cut foam cushions that contour and smooth over the GL's interior dash to ensure a secure fitting windscreen.

FACTORY INSTALLED VENT

The VStream Special Edition comes complete with vent installed. Add a set of National Cycle **Wing Deflectors™** for complete riding comfort.

PRE-TREATED WITH RAINZIP®

Our ultimate windscreen comes coated with the ultimate rain repellent: **RainZip®**. RainZip makes rainy rides a bit sunnier.



When the sun hits the Special Edition's unique gold flake finish, it dances under the protective Quantum coating.

THE BEST MATERIALS

Quantum® hardcoated polycarbonate gives outstanding strength and unbeatable scratch resistance to a National Cycle windscreen.

Polycarbonate Strength

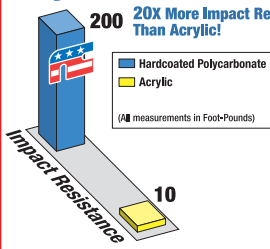

Quantum® Hardcoat

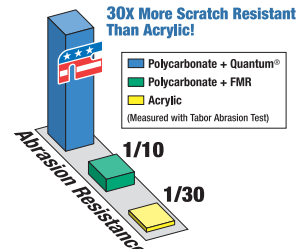

- Thick gauge material with a precision cut, smooth edge
- Quality is evident when you feel the smooth radiused edge and look at the shape of a National Cycle windshield
- 3-Year Warranty against breakage... period!



Think about riding into the sun or at night and not having to look through the glare of fine scratches! That's the Quantum® Difference!

PRODUCT SPECIFICATIONS

Part No.	Product	Color	Height	Width
2001-Current GL1800 Gold Wing®				
N20014	VStream Special Edition	Clear	25.00" (63.5cm)	26.00" (66.0cm)



VStream Special Edition Windcreens are measured from the fairing edge to the top of the screen.



Quantum is a trademark of National Cycle Inc.

WORLDWIDE LEADER IN WINDSHIELD TECHNOLOGY



national cycle[®]

**WASH'N'WIPE™ WINDSHIELDS
FULL WINDSHIELDS • LOW WINDSHIELDS
and AIRFLARES™
in QUANTUM® HARDCOATED
POLYCARBONATE!**
NEW



Catalog 1

Windshields and Their Accessories
for American and Metric Motorcycles

Catalog 2

VStream® Windscreens for
American and Metric Motorcycles

Catalog 3

Quality Riding Accessories for
American and Metric Motorcycles

Catalog 4

Wash'n'Wipe™ Windshields
and AirFlares™ for SxS UTVs

WASH'N'WIPE™

What is a Wash'n'Wipe™ Windshield?

Wash'n'Wipe is a **Quantum® hardcoated polycarbonate** (Lexan®) full-size windshield with the Wiper and Motor fully installed at our factory.

Why is This Windshield Unique?

Only National Cycle has the coating know-how and manufacturing expertise to post-coat a plastic windshield so it will hold up to repeated wiper action.

Since **1998**, National Cycle has manufactured polycarbonate windshields with wipers using this exclusive Quantum hardcoating. Quantum has surpassed all consumer and industry expectations and is the most effective hardcoating available.

Only Quantum® hardcoated polycarbonate has an **ANSI AS4/5 certification**. This allows the windshield to be used on roadways where states allow.

What is The Material Difference?

- Automotive glass is nearly twice as heavy and prone to cracking and breaking during rigorous off-road use
- Acrylic windshields are prone to scratching, cracking, and shattering, and would never stand up to the repeated windshield wiper use
- Uncoated polycarbonate scratches extremely easy
- The next best material – MR10 pre-coated polycarbonate – will fracture in the forming process, resulting in cracks and scratches



*Automotive Glass:
Great for your automobile, but
not for your off-road UTV.*



WEIGHT DIFFERENCE

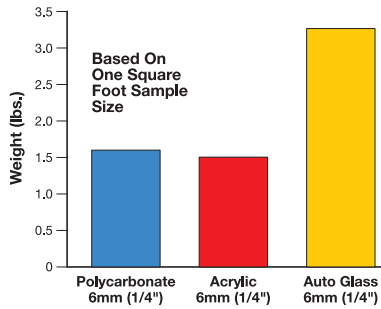

IMPACT RESISTANCE

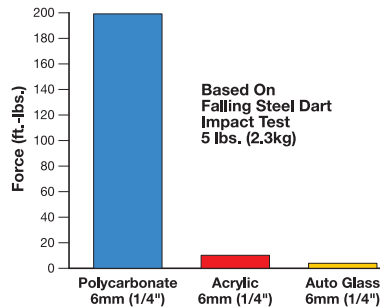

How it Mounts

National Cycle's patented **Snap-Fit™ Clamps** are attractive and rustproof. This easy-to-use, industrial-grade plastic clamp stands up to a harsh off road use.

Rain Gutter Edge

The Wash'n'Wipe model has a tightly rolled top edge and a wide-flanged rubber gasket that helps prevent water or washer fluid from rolling to the inside of the shield or cab.

Wiper Arm and Motor

A full-size wiper arm is powered by an auto-off Doga™ motor, has a molded protective cover, and is operated by a conveniently accessible toggle switch. Use National Cycle brand replacement blades – see installation manual for full details.

Washer Reservoir

The Washer Fluid Reservoir and pump secure to the inside of the vehicle. The pump switch mounts in the cab interior and has a weatherproof rating of IP-64 (dustproof and water-resistant).

Pre-Assembled for Easy Installation

The windshield, motor and wiper arm are **factory pre-assembled**, making installation a breeze. Just install the Washer Reservoir and Wire Harness and you're done



NEW 3D Formed Windshields!

Once again, National Cycle broke the boundaries of windshield design by forming **3D curvature** into the traditional flat SxS UTV windshield. This is accomplished without sacrificing the use of our tough Quantum® hardcoated polycarbonate material.

The benefits of a 3D-formed windshield are striking good looks, a beautiful cockpit view, and **substantial added rigidity**, which is particularly noticeable in full-size windshields.

National Cycle's 3D SxS windshields are now available for Polaris® RZR and Honda® Pioneer 500/700. All future SxS UTV windshields will utilize our new 3D forming technology as well.



National Cycle's 3D-formed N30002 windshield for the Honda® Pioneer features an easily adjustable air vent.



All National Cycle SxS UTV windshields come with our factory 3-Year Unbreakable Warranty. Complete warranty details available online.

NEW National Cycle AirFlares™!

UTV riders thrash around in dirt, mud, sand and rain. **National Cycle AirFlares™** not only keep pace with the terrain, but also maximize the effectiveness and extend the comfort of the front windshield on SxS vehicles. AirFlares are side shields with flared trailing edges that deflect and divert dirt, mud, sand and rain from curling into the cockpit. In addition, they are highly effective brush guards.

AIRFlares™

AirFlares are made from **Quantum® hardcoated polycarbonate** for long-lasting scratch resistance and durability. National Cycle engineers all products directly on the vehicle. Precision CNC routing and forming ensure every piece fits the vehicle it was designed for.

Installation is simple and can be done in 15 minutes or less. AirFlares mount to the vehicle's frame with a secure, no-rust, **Snap-Fit™ Clamp** system. No drilling or alteration to the vehicle is necessary.

AirFlares stand up to rugged off-road use and, when installed, maintain a clear, unobstructed view from inside the cockpit. Silkscreened details add a perfect blacked-out finishing touch to this rugged UTV product.



NEW FROM NATIONAL CYCLE

WING DEFLECTORS™



What makes a good deflector? Wing Riders: you told us and we responded. You wanted a deflector plastic that would not break, a deflector that would stay in your set position (even at speed), and a bracket that would not loosen at the joints.

We proudly introduce our **Wing Deflectors™** for the 2001 and later GL1800/1800AB!

Top Left:

N5110 Light Tint Wing Deflector; Mirror Mount; Pair

N5109 Light Tint Wing Deflector; Fairing Mount; 4-Piece Set

Top Right:

N5108 Dark Tint Wing Deflector; Mirror Mount; Pair

N5113 Dark Tint Wing Deflector; Fairing Mount; 4-Piece Set



Wing Deflectors allow maximum **temperature control** of airflow toward or away from the rider. National Cycle's unique Swivel Ratchets allow each Deflector to be incrementally adjusted by hand for personalized temperature control. No tools required!



WORLDWIDE LEADER IN WINDSHIELD TECHNOLOGY

NEW FROM NATIONAL CYCLE

PRODUCT FEATURES



- Wing Deflectors allow maximum temperature control of airflow toward or away from the rider
- These Wing Deflectors are fully road worthy – once adjusted, they stay in place, even at highway speeds

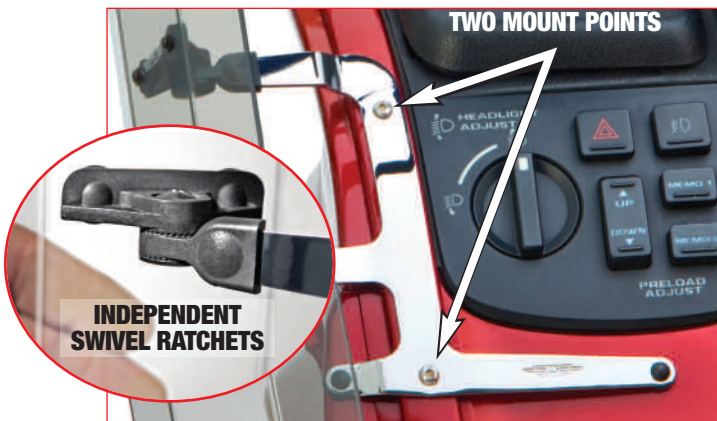

- National Cycle's unique Swivel Ratchets allow each Deflector to be incrementally adjusted for personalized temperature control
- Completely adjustable by hand – no tools required!
- Strong, one-piece chromed steel brackets will not move out of adjustment
- Easy installation – mounts to the two threaded inserts provided by Honda® under each fairing strip
- Special drill bit and template provided with the product makes drilling the side strip easy and accurate
- All stainless steel fasteners

THE BEST MATERIALS

- 3.0mm hardcoated polycarbonate material with a precision cut, smooth edge
- Stainless steel mounting hardware with show quality chrome plating
- Quality is evident in the look, fit and feel of this product
- 3-Year Warranty against breakage... period!

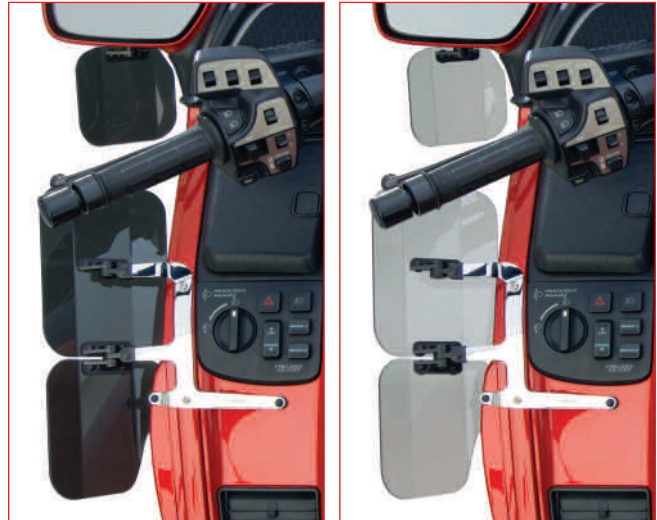

Choose from Dark Tint or Light Tint for the look you want!

PRODUCT SPECIFICATIONS

Part No.	Product	Color
GL1800 Gold Wing® 2001-10		
N5107	Wing Deflectors; Fairing Mount; 4-Piece Set	Dark Tint
N5108	Wing Deflectors; Mirror Mount; 2-Piece Set	Dark Tint
N5109	Wing Deflectors; Fairing Mount; 4-Piece Set	Light Tint
N5110	Wing Deflectors; Mirror Mount; 2-Piece Set	Light Tint
GL1800AB Gold Wing® 2006-10		
N5111	Wing Deflectors; Fairing Mount; 4-Piece Set	Dark Tint
N5108	Wing Deflectors; Mirror Mount; 2-Piece Set	Dark Tint
N5112	Wing Deflectors; Fairing Mount; 4-Piece Set	Light Tint
N5110	Wing Deflectors; Mirror Mount; 2-Piece Set	Light Tint
GL1800/1800AB/F6B Gold Wing® 2011-Current		
N5113	Wing Deflectors; Fairing Mount; 4-Piece Set	Dark Tint
N5108	Wing Deflectors; Mirror Mount; 2-Piece Set *	Dark Tint
N5114	Wing Deflectors; Fairing Mount; 4-Piece Set	Light Tint
N5110	Wing Deflectors; Mirror Mount; 2-Piece Set *	Light Tint

* Also fits GL1800 F6B



All Patents Pending.

WORLDWIDE LEADER IN WINDSHIELD TECHNOLOGY

National Cycle Street Shield EX

A bike like the Honda CB1100 is ready for action right off the showroom floor, but that doesn't mean it can't use a few accessories to customize it for an owner's purposes. A lot of riders would start with wind protection on a naked standard. Why beat yourself up when a securely fastened slab of plastic can break the breeze for you, and look good in the process? With that in mind, we fitted the National Cycle Street Shield EX to our long-term CB.

National Cycle forms their Street Shield and Street Shield EX lines from high-impact acrylic that's been UV-stabilized to prevent yellowing from sun exposure. Their proprietary No-Hole Ballssocket mount keeps the shield crack free by eliminating the need to drill holes through it, instead using attachment points bonded to the windshield. The system provides some fore/aft and vertical adjustment to customize the fit. Our EX also includes National Cycle's QuickSet Hardware, claimed to allow tool-free shield removal in 10 seconds. My best time was well beyond that, though still fast enough that I could remove the shield right before a ride without irritating my buddies waiting on their idling bikes.

Editor-in-Chief Tuttle chose and installed the Street Shield EX, but everyone who's ridden the bike has enjoyed it. Installation instructions are clear and complete; our dexterous editor had no problem



finishing the job in about an hour. The knobs and clamps are high-quality plastic parts with brass inserts, and the rods and brackets are matte black powdercoated steel. Telescoping brackets clamp to the handlebar via pivoting mounts to accept the upper struts; clamps attached to the fork tubes hold the lower struts. Once you have a good, level fit at the correct pitch, cinch things up and go for a ride. National Cycle recommends installing the shield at an angle that follows the rake of the forks. This definitely looks best, and is performing well for me.

Street Shield EX models are both wider and taller (ours is 18 inches tall and 19.25 inches wide) than non-EX models for better wind protection. A light tint overall and gradient tinting at the bottom lend a classy look to the shield. Best of all...it works. Rolling down the highway is much more comfortable with the EX than without it, especially at elevated SoCal commuting speeds. The wind hits me at the top of my helmet, there's no buffeting, and if it's really blowing I can tuck in behind it for a quiet ride.