

CELEBRATING 60 YEARS OF HELPING YOU BREAK FROM THE PACK



SIMPSON



<i>SIMPSON RACING HELMETS</i>	<i>06</i>
<i>STILO RACING HELMETS</i>	<i>21</i>
<i>SIMPSON MOTORCYCLE HELMETS</i>	<i>25</i>
<i>HEAD RESTRAINTS</i>	<i>30</i>
<i>OFF-ROAD PRODUCTS</i>	<i>41</i>
<i>RACING SUITS</i>	<i>52</i>
<i>GLOVES</i>	<i>78</i>
<i>SHOES</i>	<i>83</i>
<i>HARNESSES, NETS AND DRAG CHUTES</i>	
<i>RACING</i>	<i>89</i>
<i>AVIATION HARNESSES</i>	<i>108</i>
<i>APPAREL AND GEAR</i>	<i>109</i>

SIMPSON PERFORMANCE PRODUCTS



SIXTY YEARS OF VICTORY LAPS

SIX DECADES OF FIRSTS – FOR US AND YOU.

Since 1959, Simpson has been leading the way to help you do the same. With the sports first drag chute, fire suit and pure motorsport helmet, Simpson has been a pioneer for innovation and one of the most iconic brands in racing and riding safety.

But as any true competitor knows, you can't rest on those past accomplishments, which is why we're constantly advancing and adding to our product lines. We're as proud of where we've been as where we're going. Thanks for taking us along for the ride – and race. Here's to even more signature celebrations.

Break from the pack with Simpson.

NEW PRODUCT HIGHLIGHTS



NEW
ST5 KRT
Page 23

NEW
DESERT DEVIL
Page 11

NEW
SIX O RACING SUIT
Page 61

CERTIFICATIONS/HELMETS



FIA: The Fédération Internationale de l'Automobile (FIA), Headquartered in Paris, France, is a nonprofit organization that brings together 227 national motoring and sporting organizations from 132 countries on five continents. FIA Formula One World Championship, FIA World Rally Championship and FIA World Touring Car Championship are among the sanctioning bodies who abide by FIA standards.



SFI: The SFI Foundation, Inc. (SFI) is a nonprofit organization established to issue and administrate safety standards for specialty and performance of automotive and racing equipment. SFI oversees testing and standards for racing suits, restraints and many other high-performance safety products in the United States. NASCAR, SCCA, IRL and NHRA are among the sanctioning bodies who abide by SFI standards.



Snell: Snell Memorial Foundation is known for its ongoing work in setting, maintaining and continually upgrading helmet standards in Motorsports in the world. NASCAR, NHRA, SCCA and IRL are among the sanctioning bodies who abide by Snell helmet standards.



DOT: United States Department of Transportation – meets US DOT requirements for motorcycle helmets.



ECE 22.05: Economic Community of Europe (ECE) is the most common helmet standard used internationally. The ECE 22.05 is required by over 50 countries worldwide.

GET BEHIND THE WHEEL AND
AHEAD
OF EVERYTHING ELSE

SIMPSON
RACING HELMETS

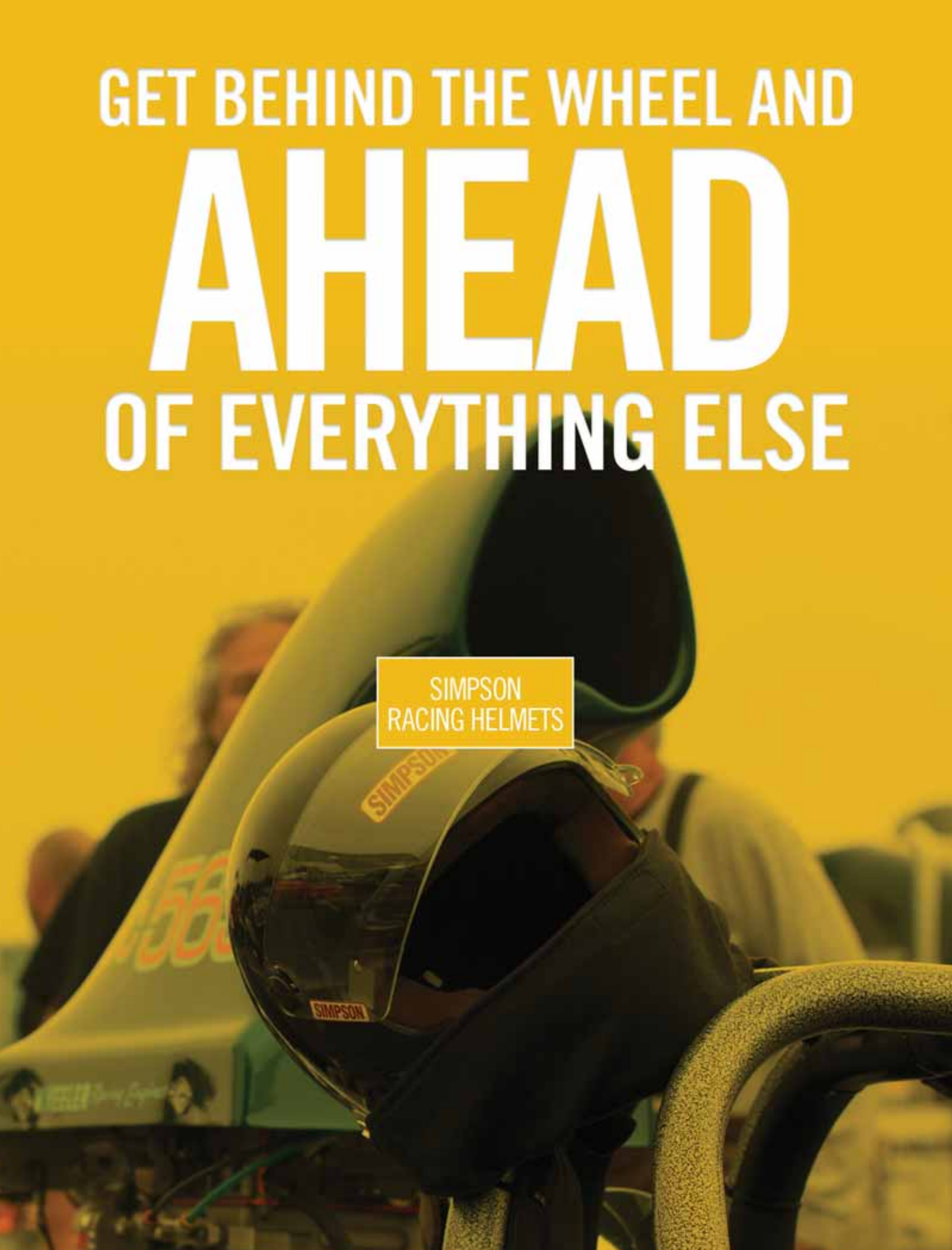

CARBON EV1

Exceptionally lightweight Auto Clave molded Carbon Fiber construction

FEATURES

- 1/3 pound lighter than composite Vudo EV1
- Recessed eye port ensures 100% shield seal
- Head Restraint-ready
- Includes padded helmet bag
- Radio communications may be added



CODE: **663C** SIZE: **7 1/8 - 7 3/4**

RECOMMENDED FOR REPLACEMENT SHIELDS 101 SERIES

Circle Track	CODE: 1010-17	COLOR: CLEAR
Dirt Track	CODE: 1011-17	COLOR: SMOKE
Drag	CODE: 1012-17	COLOR: AMBER
Karting	CODE: 1013-17	COLOR: IRIIDIUM
Off-Road	CODE: 1014-17	COLOR: MIRROR
Road Racing		

New 101 Series injection molded shields provide exceptional clarity and no distortion.

Carbon helmets are light on the head but heavy on safety.

TOP SIDE AIR OPTIONS AVAILABLE RIGHT
CODE: 97032
LEFT CODE: 97033



CARBON AIR INFORCER VUDO

Made from exceptionally lightweight, Auto Clave Molded Carbon Fiber

FEATURES

- 1/3 lbs. lighter than composite Air Inforcer Vudo
- Design features include a stylish top cap designed for better pipe placement and a low profile for multiple roof/driver height
- Recessed eye port offers a 100% shield seal
- Radio communications may be added
- Includes helmet bag
- Head Restraint-ready



CODE: **662C** SIZE: **7 1/8 - 7 3/4**

RECOMMENDED FOR REPLACEMENT SHIELDS 101 SERIES

Circle Track	CODE: 1010-17	COLOR: CLEAR
Dirt Track	CODE: 1011-17	COLOR: SMOKE
Off-Road	CODE: 1012-17	COLOR: AMBER
Road Racing	CODE: 1013-17	COLOR: IRIIDIUM
	CODE: 1014-17	COLOR: MIRROR

New 101 Series injection molded shields provide exceptional clarity and no distortion.

CARBON DEVIL RAY

The Devil Ray has an exceptionally lightweight carbon shell that weighs in at 2.9 lbs. for size Medium

FEATURES

- FIA 8859 2015 and Snell SA2015 Certified
- Radio communications may be added
- Top air and side pipe options available, Head Restraint-ready
- Includes padded helmet bag



CODE: **683C** SIZE: **XS - XXL**

RECOMMENDED FOR REPLACEMENT SHIELDS 84300 SERIES

Circle Track	CODE: 84300A	COLOR: CLEAR
Dirt Track	CODE: 84301A	COLOR: SMOKE
Drag	CODE: 84304A	COLOR: AMBER
Karting	CODE: 84303	COLOR: IRIIDIUM
Off-Road	CODE: 84306A	COLOR: MIRROR
Road Racing		

FORCED AIR TOP OFFSET
RIGHT CODE: 97032
LEFT CODE: 97033



FORCED AIR TOP
CODE: 97034



FORCED AIR SIDE
CODE: 97009



DEVIL RAY PEAK
CODE: PEAKDR



SIMPSON RACING HELMETS

CARBON BANDIT

Classic Bandit flagship design, improved aerodynamics through design innovation.

FEATURES

FIA 8859-2015 approved. Snell SA 2015 certified.

Radio communications may be added
Side pipe option available
Includes helmet bag
Head Restraint-ready



CODE:	TYPE:	SIZE:
620C	CARBON BANDIT	XS-XXL

CODE:	TYPE:	SIZE:
622C	CARBON DRAG BANDIT	XS-XXL

RECOMMENDED FOR

Circle Track
Dirt Track
Off-Road
Road Racing

REPLACEMENT SHIELDS 89400 SERIES

CODE:	COLOR:
89400A	CLEAR
89401A	SMOKE
89402A	IRIDIUM
89403	AMBER
89406A	MIRROR

FORCED AIR SIDE
CODE: 97009

FORCED AIR TOP (NOT SHOWN)
CODE: 97027CLR

CARBON DIAMONDBACK



The Carbon Diamondback is Snell SA 2015 RATED and manufactured in the USA of exceptionally lightweight, Auto Clave Molded Carbon Fiber.

FEATURES

Defined Wave Eliminators for reduced buffeting
Optimally designed shield pivot system
Recessed eye port offers a 100% shield seal
Radio communications may be added
Side pipe air option available
Helmet bag included
Head Restraint-ready

CODE:	SIZE:
629C	7 1/8 - 7 3/4

RECOMMENDED FOR

Circle Track
Dirt Track
Drag
Karting
Off-Road
Road Racing

REPLACEMENT SHIELDS 102 SERIES

CODE:	COLOR:
1020-17	CLEAR
1021-17	SMOKE
1022-17	AMBER
1023-17	IRIDIUM
1024-17	MIRROR



VENATOR CARBON FIBER

The Venator features a plush interior with gel ear cups and optional padded ear inserts.

FEATURES

FIA 8859-2015 approved
Snell SA 2015 certified
Plush interior with Simpson branding on cheeks
Gel ear cups and optional padded ear inserts
Head Restraint-ready
Includes padded helmet bag
Radio communications may be added
Top air and side pipe options available
FORCED AIR TOP (NOT SHOWN) CODE: 97027
FORCED AIR SIDE (NOT SHOWN) CODE: 97009



CODE:	TYPE:	SIZE:
685C	VENATOR CARBON FIBER	XS-XXL

RECOMMENDED FOR

Circle Track
Dirt Track
Drag
Karting
Off-Road
Road Racing

REPLACEMENT SHIELDS 84500 SERIES

CODE:	COLOR:
84500	CLEAR
84501	SMOKE
84502	AMBER
84503	IRIDIUM
84504	MIRROR

CODE:	TYPE:	SIZE:
686C	VENATOR PRO FIA 8860	XS-XL

FIA 8860-2015 approved. Snell SA 2015 certified.

METRIC SIZE	54 CM	56 CM	57 CM	59 CM	60 CM	62 CM
HELMET SIZE	XS	S	M	M/L	L	XL



SPEEDWAY SHARK

The Speedway Shark helmet has defined wave eliminators for reduced buffeting.

FEATURES

Head Restraint-ready
Includes helmet bag
Radio communications may be added

COLORS

White, Gloss Black, +30 Matte Black, Blue, Red, Safety Orange, Silver and Pearl White



CODE: **670** SIZE: **7 1/8 - 7 3/4**

RECOMMENDED FOR REPLACEMENT SHIELDS 101 SERIES

Circle Track	CODE: 1010-17	COLOR: CLEAR
Dirt Track	1011-17	SMOKE
Karting	1012-17	AMBER
Off-Road	1013-17	IRIDIUM
Road Racing	1014-17	MIRROR

New 101 Series injection-molded shields provide exceptional clarity and no distortion.

AIR INFORCER SHARK

Design features include a stylish top cap designed for better pipe placement and a low profile for multiple roof/driver height.

FEATURES

Recessed eye port offers a 100% shield seal
Radio communications may be added
Includes helmet bag
Head Restraint-ready

COLORS

White, Gloss Black, +30 Matte Black, Blue, Red, Safety Orange, Silver and Pearl White



CODE: **677** SIZE: **7 1/8 - 7 3/4**

RECOMMENDED FOR REPLACEMENT SHIELDS 101 SERIES

Circle Track	CODE: 1010-17	COLOR: CLEAR
Dirt Track	1011-17	SMOKE
Off-Road	1012-17	AMBER
Road Racing	1013-17	IRIDIUM
	1014-17	MIRROR

New 101 Series injection-molded shields provide exceptional clarity and no distortion.



WRAP AROUND AIR

Wrap around constructed from Auto Clave molded carbon fiber.
CODE: 97058



AIR INFORCER VUDO

Design features include a stylish top cap designed for better pipe placement and a low profile for multiple roof/driver height.

FEATURES

Recessed eye port with 100% shield seal
Head Restraint-ready
Radio communications may be added
Includes a helmet bag

COLORS:

White, Gloss Black, +30 Matte Black, Blue, Red, Safety Orange, Silver and Pearl White



CODE: **662** SIZE: **7 1/8 - 7 3/4**

RECOMMENDED FOR REPLACEMENT SHIELDS 101 SERIES

Circle Track	CODE: 1010-17	COLOR: CLEAR
Dirt Track	1011-17	SMOKE
Off-Road	1012-17	AMBER
Road Racing	1013-17	IRIDIUM
	1014-17	MIRROR

New 101 Series injection-molded shields provide exceptional clarity and no distortion.

SIMPSON RACING HELMETS



VUDO EV1

The Vudo EV1 features a chin bar that offers excellent coverage.

FEATURES

Shield pivot system opens and closes with ease.
A recessed eye port offers 100% shield seal.
Radio communications may be added
Includes a helmet bag
Head Restraint-ready

COLORS

White, Gloss Black, +30 Matte Black, Blue, Red, Safety Orange, Silver and Pearl White



CODE: **663** SIZE: **7 1/8 - 7 3/4**

RECOMMENDED FOR REPLACEMENT SHIELDS 101 SERIES

Dirt Track	CODE: 1010-17	COLOR: CLEAR
Off-Road	1011-17	SMOKE
Karting	1012-17	AMBER
Road Racing	1013-17	IRIDIUM
Stock Car	1014-17	MIRROR

New 101 Series injection-molded shields provide exceptional clarity and no distortion.

NEW DR 2

The DR2 or Devil Ray 2 is a modified version of the Devil Ray helmet, homologated to Snell SA2015 certification with loads of new features including a new clear air pipe for top air, or a side air offset.

FEATURES

Lightweight shell construction
Features recessed area for ear cups
Additional air flow
Removable cheek pads and top pads for a custom fit
Compatible with the Devil Ray shield and pivot system
New clear air pipe for top air.
Side and offset air available.

COLORS

White, Gloss Black



CODE: **684** SIZE: **XS-XXL**

RECOMMENDED FOR REPLACEMENT SHIELDS 84300 SERIES

Dirt Track	CODE: 84300A	COLOR: CLEAR
Off-Road	84301A	SMOKE
Karting	84303	IRIDIUM
Road Racing	84304A	AMBER
Stock Car	84306A	MIRROR

The DR2 model comes ready for electronics and air supply. The air options can be added without drilling holes into the helmet which allows the customer to try different options without the worry of destroying a helmet.

The DR2 model offers improved comfort and fit while maintaining the level of quality found in the Devil Ray. Ventilation was added to the DR2 model in order to let heat escape and keep the driver comfortable. Non-integrated accessories can be purchased and installed by the customer or at the factory.

DEVIL RAY COMPOSITE

Our popular Devil Ray Carbon helmet is now available in a composite version with the same outstanding customizable features as our Carbon Devil Ray. Composite weighs a little more than carbon, but if you are looking for an incredible value, the composite Devil Ray is for you.

FEATURES

Snell SA2015 certified
Required protection at a lower price
Devil Ray has the most add-on features, including a peak for blocking the sun
High-quality fit with removable cheek pads
Helmet includes a smaller set of cheek pads to improve the fit of the helmet if needed
Head restraint-ready

COLORS

White, Gloss Black



CODE: **683** SIZE: **XS-XXL**

RECOMMENDED FOR REPLACEMENT SHIELDS 84300 SERIES

Circle Track	CODE: 84300A	COLOR: CLEAR
Dirt Track	84301A	SMOKE
Drag	84303	IRIDIUM
Karting	84304A	AMBER
Off-Road	84306A	MIRROR
Road Racing		

FORCED AIR TOP
CODE: 97034

FORCED AIR TOP OFFSET
RIGHT CODE: 97032
LEFT CODE: 97033

FORCED AIR SIDE
CODE: 97009

DEVIL RAY PEAK
CODE: PEAKDR

NEW DESERT DEVIL

The Desert Devil Off Road Helmet System includes our popular Devil Ray Snell SA 2015 rated helmet, equipped with an offset top air pipe and off road communication kit. Pop the helmet out of the box and you are ready to go riding.

The off-road communications kit comes with a 3.5mm headphone connection that can be plugged into your mobile phone for music using an auxiliary cord easily purchased from your favorite electronics store. The offset top air pipe gives extra head clearance in the vehicle.

FEATURES

- Lightweight shell construction; Snell SA 2015 Rated
- Includes off-set top air (left side only)
- Includes off-road communication kit with flex boom and water-resistant connections
- Includes integrated speakers
- Removable cheek pads



CODE: **682** TYPE: **WHITE, GLOSS BLACK** SIZE: **XS-XXL**

CODE: **682** TYPE: **CARBON FIBER** SIZE: **XS-XXL**

RECOMMENDED FOR REPLACEMENT SHIELDS 84300 SERIES

RECOMMENDED FOR	CODE:	COLOR:
Circle Track	84300A	CLEAR
Dirt Track	84301A	SMOKE
Off-Road	84303	IRIDIUM
Road Racing	84304A	AMBER
	84306A	MIRROR

COLORS

White, Gloss Black, and Carbon fiber



SUPER BANDIT

Classic flagship Bandit design remains true to Simpson's heritage for distinct style and helmets you can trust to do their job.

FEATURES

- Snell SA 2015 rated
- Head Restraint-ready
- Radio communications may be added

COLORS

White, Gloss Black, +30 Matte Black, Blue, Red, Safety Orange, Silver and Pearl White



CODE: **621** SIZE: **XS - XXL**

RECOMMENDED FOR REPLACEMENT SHIELDS 89400 SERIES

RECOMMENDED FOR	CODE:	COLOR:
Circle Track	89400A	CLEAR
Dirt Track	89401A	SMOKE
Drag	89402	IRIDIUM
Karting	89403A	AMBER
Off-Road	89406A	MIRROR
Road Racing		

FORCED AIR TOP (NOT SHOWN)
CODE: 97027CLR

FORCED AIR SIDE
CODE: 97009



BANDIT

Classic flagship Bandit design remains true to Simpson's heritage for distinct style and helmets you can trust to do their job.

FEATURES

- FIA 8859-2015 approved. Snell SA 2015 certified.
- Head Restraint-ready
- Radio communications may be added

COLORS

White, Gloss Black, +30 Matte Black



CODE: **620** SIZE: **XS - XXL**

RECOMMENDED FOR REPLACEMENT SHIELDS 89400 SERIES

RECOMMENDED FOR	CODE:	COLOR:
Circle Track	89400A	CLEAR
Dirt Track	89401A	SMOKE
Drag	89402	IRIDIUM
Karting	89403A	AMBER
Off-Road	89406A	MIRROR
Road Racing		

SIMPSON RACING HELMETS

DRAG BANDIT

FEATURES

Head Restraint-ready
Drag Sock is SFI.10 rated

COLORS

White, Gloss Black, +30 Matte Black, Blue, Red, Safety Orange, Silver and Pearl White



CODE: **622** SIZE: **XS-XXL**

RECOMMENDED FOR REPLACEMENT SHIELDS 89400 SERIES

Drag Racing	CODE: 89400A 89401A 89402 89403A 89406A	COLOR: CLEAR SMOKE IRIDIUM AMBER MIRROR
-------------	--	--

DIAMONDBACK

The Diamondback features defined wave eliminators for reduced buffeting.

FEATURES

Recessed eye port offers a 100% shield seal
Head Restraint-ready
Radio communications may be added
Side pipe air option available

COLORS:

White, Gloss Black, +30 Matte Black, Blue, Red, Safety Orange, Silver and Pearl White



CODE: **629** SIZE: **7 1/8 - 7 3/4**

RECOMMENDED FOR REPLACEMENT SHIELDS 102 SERIES

Circle Track	CODE: 1020-17 1021-17 1022-17 1023-17 1024-17	COLOR: CLEAR SMOKE AMBER IRIDIUM MIRROR
Dirt Track		
Drag		
Karting		
Off-Road		
Road Racing		

SIDE PIPE OPTION
CODE: 97009



SPEEDWAY RX

Classic "RX" styling with defined Wave Eliminators for reduced buffeting.

FEATURES

Radio communications may be added
Head Restraint-ready

COLORS:

White, Gloss Black, +30 Matte Black, Blue, Red, Safety Orange, Silver and Pearl White



CODE: **651** SIZE: **7 1/8 - 7 3/4**

CODE: TYPE: **653 DRAG RX WITH BUILT-IN DRAG SOCK (NOT SHOWN)**

RECOMMENDED FOR REPLACEMENT SHIELDS 102 SERIES

Dirt Track	CODE: 1020-17 1021-17 1022-17 1023-17 1024-17	COLOR: CLEAR SMOKE AMBER IRIDIUM MIRROR
Drag Racing		
Karting		
Off-Road		
Road Racing		
Stock Car		



VENATOR COMPOSITE



The composite Venator available in colors to complement your race car and racing suit. The Venator features a plush interior with gel ear cups and optional padded ear inserts.

FEATURES

FIA 8859-2015 approved. Snell SA 2015 certified.
Plush interior with Simpson branding on cheeks
Gel ear cups
Optional padded ear inserts
Head Restraint-ready
Radio communications may be added
Top pipe and side pipe options available

COLORS

White, Gloss Black, +30 Matte Black

TOP AIR OPTION
CODE: 97027

CODE: **685** SIZE: **XS - XXL**

RECOMMENDED FOR REPLACEMENT SHIELDS 84500 SERIES

Circle Track	CODE: 84500	COLOR: CLEAR
Dirt Track	84501	SMOKE
Drag	84502	AMBER
Karting	84503	IRIDIUM
Off-Road	84504	MIRROR

TOP AIR OPTION
CODE: 97027

SIDE AIR OPTION
CODE: 97009

Venator Chin Guard

CODE: 97010
97011

FITS
XS - M/L
L - XXL

VENATOR
CHIN GUARD



VOYAGER 2

The Voyager 2 is a redesign for one of our customer favorites, featuring our largest eye port for excellent field of vision. The helmet interior included contrast stitching and branding.

FEATURES

Snell SA 2015 approved
Head Restraint-ready
Radio communications may be added

COLORS

White, Gloss Black, +30 Matte Black



CODE: **610** SIZE: **XS - XXL**

RECOMMENDED FOR REPLACEMENT SHIELDS 88800 SERIES

Circle Track	CODE: 88800A	COLOR: CLEAR
Dirt Track	88801A	SMOKE
Drag	88802A	AMBER
Karting	88803A	IRIDIUM
Off-Road	88804A	MIRROR

Road Racing
Car Club Enthusiasts



TOP AIR OPTION
CODE: 97027



JUNIOR SPEEDWAY SHARK



The Jr. Speedway Shark is proportionately sized for younger racers.

FEATURES

SFI 24.1 approved
Head Restraint-ready
Radio communications may be added

COLORS

White, Gloss Black, +30 Matte Black, Blue, Red, Safety Orange, Silver and Pearl White

CODE: **178** SIZE: **6 1/2 - 6 5/8**

RECOMMENDED FOR REPLACEMENT SHIELDS J8860 SERIES

Circle Track	CODE: J88600	COLOR: CLEAR
Dirt Track	J88601	SMOKE
Drag	J88603	AMBER

SIMPSON RACING HELMETS



FR CRUISER

Designed for racers who prefer an open face helmet.

FEATURES

Snell SA 2015 approved
Head Restraint-ready

COLORS

White and Gloss black



CODE:
632

SIZE:
XS - XXL

RECOMMENDED FOR

Circle Track
Drag
Off-Road
Road Racing
Car Club Enthusiasts

REPLACEMENT VISOR
CODE:
99502



PIT WARRIOR CREW

The Pit Warrior is worn by professional crews and off-road enthusiasts. Removable and washable interior. Wide field of vision, open face design, lightweight. Fourteen strategically placed vents offer excellent air flow. Factory-installed radio communications available.

COLORS

Matte Black, White

CODE:
145

SIZE:
S - XXL

RECOMMENDED FOR

Pit Crew Members

REPLACEMENT VISOR
CODE:
145VIS

OTW SHORTY

The OTW Shorty is DOT Rated. Includes 4-way adjustable strap system and glare-reducing visor.

COLORS

Black, White



CODE:
143

SIZE:
XS - XL

RECOMMENDED FOR

Pit Crew Members



MEMORABILIA AUTOGRAPH HELMET

A blank signature helmet for your favorite autographs.

COLORS

White, Black and Matte Black

For display only. Do not wear for racing.

CODE:
2130001
2130002
2130008

COLOR:
WHITE
BLACK
MATTE BLACK

CUSTOM COLORS

Custom paint colors are available by special order on all Simpson helmets manufactured at our New Braunfels, Texas, facility. Available helmet paint colors include Black and White, at no additional charge, or any of the 6 additional colors shown below, at a small.

Available for **Speedway Shark, Air Inforcer Shark, Air Inforcer Vudo, Vudo EV1, Speedway RX, Diamondback, Super Bandit, Drag Bandit, and Jr. Speedway Shark** models.

Custom Colors
Shown on the **Diamondback**



* Fluorescent paint has limited UV Protection

MEASURING FOR A HELMET

A correctly fitted helmet should feel like an even amount of pressure is being exerted around your head and cheeks. But helmets break in, so it should fit as tight as you can comfortably wear it. Once fastened, you should NOT be able to pull it off your head in any direction. Attention first-time helmet buyers: If your helmet is loose at all, and doesn't fit well, it CANNOT deliver the best protection. A helmet's strict safety standards can be compromised after only one impact collision. If the integrity is in question, send it back to us for proper inspection.

MEASURE DIRECTLY ABOVE THE BROW LINE FOR THE BEST HELMET FIT.

Simpson Recommends Inspection Of Your Helmet After Any Impact Collision.

ADULT HELMET SIZE CHART

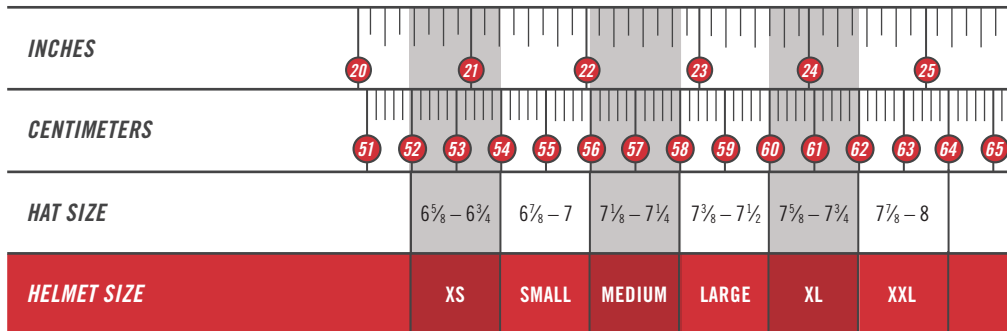

YOUTH HELMET SIZE CHART



SIMPSON RACING HELMETS



NEW MULTI-EQUIPMENT DRYER FOR HELMET, GLOVES AND FOOTWEAR

Simpson's newest antibacterial multi-equipment dryer circulates air in a temperature-controlled environment to safely dry helmets, gloves and footwear.

It's hard to put that wet smelly helmet on your head. What's happening to your expensive equipment? The truth is cheek pads and liners degrade over time from perspiration and bacteria. Keep your equipment in peak condition longer by stopping mold and mildew before it starts. You can focus on your driving or riding and quickly refresh between events.

CODE:
97100

FEATURES
Anti-bacterial, eliminates odors and controls bacteria growth
Dual dryer ports
110 volt



RACING OPTICS AND STILO TEAROFFS

2mm laminated tearoffs. 3 Speedstacks™ of 10 tearoffs.



CODE 98022 FITS GOLD ALUMINUM TEAROFF POSTS. FITS: ALL MODELS



stilo

Any competition one helmet

Laminated tearoffs

CODE	FITS
10201C	VOYAGER HELMET MODEL 410
10203C	JR. SPEEDWAY SHARK
10204C	RX, SUPER BANDIT, BANDIT, X BANDIT, DIAMONDBACK
10209C	SUPER SHARK, VUDO, AIR INFORCER SHARK, DEVIL RAY, VOYAGER EVOLUTION, SIDEWINDER VOYAGER, VOYAGER 2, SNELL SA 2015 MODELS
10210C	VENATOR

Stilo tearoffs

CODE	FITS
10259C	STILO ST5 SMALL TAB
10252C	STILO ST5 LARGE TAB
10253C	STILO ST5 DIRT MARKET

NEW ACRY SOL SHIELD CLEANER

Acrysol shield cleaner is recommended by Stilo for helmet shield care. Acrysol is also compatible with Simpson helmet shields.



CODE:
YA0640

DUAL SHIELD BAG



CODE:
23900

REPLACEMENT SHIELDS

101 SERIES - FITS SHARK AND VUDO MODELS

CODE:	COLOR:
1010-17	CLEAR
1011-17	SMOKE
1012-17	AMBER
1013-17	IRIDIUM
1014-17	MIRROR

New 101 Series injection molded shields provide exceptional clarity and no distortion.

102 SERIES - FITS X BANDIT, DIAMONDBACK, SKULL AND RX MODELS

CODE:	COLOR:
1020-17	CLEAR
1021-17	SMOKE
1022-17	AMBER
1023-17	IRIDIUM
1024-17	MIRROR

103 SERIES - FITS SA10 SW VOYAGER, VOYAGER EVOLUTION AND BULL DOG

CODE:	COLOR:
1030-12	CLEAR
1031-12	SMOKE
1032-12	AMBER
1033-12	IRIDIUM
1034-12	MIRROR

ADDITIONAL

SNELL 2010 AND 2015 HELMET SHIELDS

Clear and Smoke prices listed.

CODE:
84300 SERIES

89400 SERIES

89100 SERIES

88200A SERIES

89900 SERIES

86030 SERIES

84500 SERIES

88800 SERIES

FITS:
DEVIL RAY

BANDIT, SUPER BANDIT,
CARBON BANDIT,
DRAG BANDIT, CH3N02

OUTLAW BANDIT

VOYAGER, MODEL 410

K10, KART HELMET

STREET BANDIT

VENATOR

VOYAGER 2

PIVOT KITS

DETENT PIVOT KITS

Hardware included.

CODE:
99014

99013

99016

99022

99002

99018

FITS:
101, 102, 103 SERIES
AND VOYAGER 2 SHIELDS
DEVIL RAY
BANDIT/CARBON BANDIT
VOYAGER MODEL 410
SUPER BANDIT
VENATOR



SIMPSON RACING HELMETS

RADIO COMMUNICATION



Simpson is proud to offer Rugged Radio's exclusive communication technology for Racing Radio Driver and Crew Communication systems. Order your favorite Simpson helmet complete with factory-installed communications equipment. Save time, save on shipping charges. Helmet kit pricing as shown includes installation. Simpson helmets are fully certified to be Snell and/or FIA compliant when equipped with Rugged Radios helmet kit installations. PCI Radios also available for off-road applications.

OFF-ROAD HELMET KIT

Kit Includes Flex Boom, Helmet Speakers and 3.5 mm Ear Bud Jack



This complete off-road flex boom helmet kit features Rugged Radios' new Dura-Link Sealed Connector, Clear Hear speakers and dynamic noise canceling mic for best audio performance, and 3.5mm input port for music cable or ear buds. The Dura-Link Seal, featured on all Rugged helmet kits, seals the connection between the intercom cable and helmet kit plug. The Dura-Link Seal protects the connection contacts from water, mud and dirt which can affect audio performance and works with current Rugged off-road intercom cables.

CODE	TYPE
96044	OFF-ROAD HELMET KIT

PRICE

EAR CUPS



CODE	TYPE
96002	EAR CUPS W/SPEAKERS & INSTALLED (ONE WAY RADIO)
96001	EAR CUPS INSTALLED, W/O SPEAKERS
96000	EAR CUPS, W/O INSTALLATION AND SPEAKERS

NASCAR HELMET KIT

The National Association for Stock Car Auto Racing



CODE	TYPE
96023	NASCAR HELMET KIT (3 COND) W/FLEX BOOM & COIL WITH EAR CUP SPEAKERS
96033	

NASCAR HELMET KIT

The National Association for Stock Car Auto Racing



CODE	TYPE
96003	NASCAR HELMET KIT (3 COND) W/FLEX BOOM & STRAIGHT CORD WITH EAR CUP SPEAKERS
96013	

IMSA HELMET KIT

The International Motor Sports Association



CODE	TYPE
96024	IMSA HELMET KIT (4 COND) W/FLEX BOOM & COIL CORD WITH EAR CUP SPEAKERS
96034	

IMSA HELMET KIT

The International Motor Sports Association



CODE	TYPE
96004	IMSA HELMET KIT (4 COND) W/FLEX BOOM & STRAIGHT CORD WITH EAR CUP SPEAKERS
96014	

HELMET EJECT AND EMS



Simpson's Eject Helmet Removal System is a small air bladder that fits easily into any helmet, without changing its fit or feel. In the event of a crash, First Responders can help reduce the risk of secondary neck or spine injuries by inflating the Eject System which gently lifts the helmet off the head.

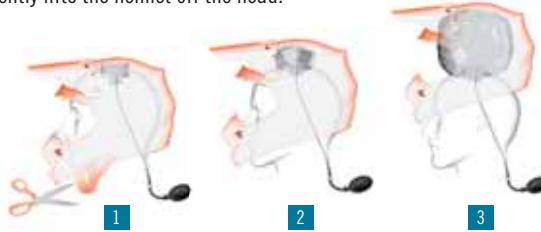

EJECT EMT AMBULANCE/TRACK KIT

Complete Eject Kit for track or ambulance contains:

- 3 EMT Helmet Bladders
- 1 Bulb Inflator
- 1 CO2 Inflator
- 4 CO2 Cartridges (16 grams each)
- 1 Track Bag



CODE
898-01-KIT

EJECT CO2 CARTRIDGE

Carbon Dioxide cartridge for Eject CO2 Inflator



CODE
896-01-30-B

EJECT EMT BLADDER

Air bladder with attached hose for helmet installation.



CODE
892-01-BLR

EJECT BULB INFLATOR

Eject Inflator powered by a small rubber bulb



CODE
897-01-30

EJECT CO2 INFLATOR

Eject Inflator powered by a small Carbon Dioxide cartridge. Includes one cartridge. Additional cartridges sold separately.



CODE
895-01-30

EJECT BLADDER

Eject and installation.



CODE
890-01-30
890-01-30I

TYPE
EJECT BLADDER
EJECT BLADDER W/ INSTALL

SIMPSON RACING HELMETS

BUILT IN HELMET SKIRTS



Helmet Skirts

CODE	FITS
97008	SFI 3.3/5 CarbonX®
97028	SFI 3.3/10 CarbonX®
97038	SFI 3.3/5 CarbonX® CONTOURED HELMET SKIRT
97048	SFI 3.3/10 CarbonX® CONTOURED HELMET SKIRT



F/C AIR SYSTEM

DRAG SOCK

THE F/C AIR SYSTEMS



Can be installed on most Simpson fullface helmets. Advanced internal airflow system distributes fresh air throughout, with venting to the mouth/nose, and 2 clearing ports on each side to eliminate fogging. Drag sock and Kevlar® gasket purchased separately. Requires use of drag sock.

Drag Air System

CODE:
97025

Drag Sock

SFI 3.3/10 CarbonX®, built in drag sock

CODE:
97003

THE F/C EXTERNAL AIR SYSTEM

The F/C Air System was designed in 1998 to provide constant flow or on-demand air to the driver in the event of a fire. Composite bottle will hold 5 to 10 minutes of air, depending on flow setting. System includes Flow Control Regulator, ball valve, 8 ft. fire rated hose, hose fittings and 3000 PSI rated bottle (114 cubic inches) and shut-off valve assembly.



Air System

CODE:
FCC



BREATH DEFLECTOR

Helps seal mouth and nose area and keeps fresh air in and unwanted fumes out. Can be molded to conform to contours of nose. Prevents fogging and can be used in conjunction with Sidewinder F.A.S. Must have helmet to install at factory.

Adjustable Breath Deflector (Shown)
Breath Deflector

CODE:
97035
97022

CHIN FLAP (NOT SHOWN)



Helps seal area under chin to prevent air flow that can cause lift. Prevents dust and debris from entering helmet. Reduces noise while improving microphone pickup. Must have helmet to install at factory.

Chin Flap

CODE:
97015

TRAVEL AT THE SPEED OF LIGHTER

STILO RACING
HELMETS



STILO RACING HELMETS

STILO RACING HELMETS

Stilo helmets are some of the lightest in the world. They're worn by winning drivers worldwide including F1 Mercedes driver Valtteri Bottas, Monster Energy NASCAR Cup Series champions Jimmie Johnson and Kyle Busch, IndyCar Series champion Tony Kanaan and rising star Pato O'Ward and WRC champion Sébastien Loeb. Stilo is the first helmet manufacturer to achieve the FIA's prestigious 8860-2018 standard. Demand the best, be the best.



ST5 FN
ZERO 8860



ST5 GT
CARBON

stilo

Any competition one helmet



ST5 GT COMPOSITE



ESAPEKKA LAPPI, WRC DRIVER

STILO KART HELMETS

Turn heads with a style that closely resembles the top range Stilo ST5 Zero helmet. A safer helmet means faster laps.

YOUTH
RATED

ST5 CMR

Colors: Matte Black (shown) and White



SNELL
K 2015 RATED

ST5 KRT

Shown with back spoiler and front spoiler

Color: White



PATO O'WARD, INDYCAR DRIVER

STILO HELMET SIZE CHART

SIZE	CENTIMETERS	INCHES	US HAT SIZE	US HAT SIZE
XS	53 - 54 CM	21 - 21¼	6⅝ - 6¾	SMALL SHELL
SMALL	55 - 56 CM	21⅝ - 22	6⅞ - 7	SMALL SHELL
MEDIUM	57 - 58 CM	22¼ - 22¾	7⅞ - 7¼	SMALL SHELL
LARGE	59 - 60 CM	23¼ - 23⅝	7¼ - 7½	SMALL SHELL
LARGE PLUS	60 - 61 CM	23¼ - 23⅝	7¼ - 7½	LARGE SHELL
XL	61 - 62 CM	24 - 24⅝	7⅞ - 7¾	LARGE SHELL
XXL	63 - 64 CM	24¼ - 25⅝	7⅞ - 8	LARGE SHELL
XXXL	64 - 65 CM	25⅝ - 25½	8 - 8⅞	LARGE SHELL

STILO RALLY HELMETS

STILO RALLY HELMETS



TROPHY JET

ST5 Style with sunshield option, great value, included microphone holder



TROPHY DES PLUS

Snell 2015 certified open face design for Rally and Autocross, with electronics



WRC DES ZERO 8860

Setting the bar for rally drivers and navigators. Fully customizable.



WRC DES CARBON PIUMA

An integrated microphone boom sets the WRC DES apart from other open face helmets

DON'T JUST RIDE LIKE YOU
STOLE IT
LOOK LIKE YOU STOLE IT

SIMPSON
MOTORCYCLE HELMETS



SIMPSON MOTORCYCLE HELMETS

NEW MOD BANDIT



ECE 22.05
Approved



Modular function and convenience meets Simpson style and attitude.

One hand modular function, communication system ready, Pinlock system compatible, and internal sun shield are highlights of the new Mod Bandit. Ready to ride across town or around the world, the Mod Bandit offers the function and style you are looking for.

FEATURES:

- DOT/ECE certification
- Tri composite or carbon fiber shell combined with a polycarbonate alloy chin bar
- One hand chin bar opening
- Ability to lock the chin bar in the open position
- Metal chin bar locking components for strength and durability
- Communication system compatibility
- Multiple adjustable intake vents
- Free flow, low pressure exhaust vents aids in air extraction
- Integrated spoiler maximizes stability and aids in air extraction
- Removable, washable, hypoallergenic and antimicrobial cheek pads and interior
- Pinlock shield insert ready
- Toolless, quick release, shield changing
- Smoke tinted internal sun shield, other options available
- Rear facing cheek pad reflective panels
- Removable, noise reducing chin curtain
- Traditional, double D-ring retention system

COLORS

White, Black, Flat Black, Carbon

Composite

CODE: **M59** SIZE: **XS - XXL**

Carbon Fiber

CODE: **M59** SIZE: **XS - XXL**

REPLACEMENT SHIELDS MB SERIES

EXTERIOR SHIELDS

CODE:	COLOR:
MBCSE	CLEAR
MBSSE	SMOKE
MBASE	AMBER
MBISE	IRIDIUM
MBMSE	MIRROR
MBGSE	GOLD MIRROR

INTERIOR SHIELDS

CODE:	COLOR:
GBCSI	CLEAR
GBLSSI	LIGHT SMOKE
GBDSSI	SMOKE
GBASI	AMBER



MOD Bandit shown in various positions

GHOST BANDIT



Designed 100% with motorcycle riders in mind, the Simpson Ghost Bandit is prepared to handle just about any type of riding in killer style and complete comfort. The lightweight shell has been aerodynamically tuned for motorcycle riding, and is fully ventilated for maximum airflow when, and where, you need it most. Integrated speakers and microphone pockets make it easy to install your favorite communication device, and a drop-down sun visor makes riding through changing light conditions a breeze.

FEATURES

- Lightweight Composite and Carbon Fiber versions
- DOT/ECE Certified
- Removable liner
- Internal sun visor
- Multiple shield options
- Integrated speaker and boom mic pockets
- Dual adjustable chin vents
- Top and rear ventilation
- Removable chin air dam

COLORS

White, Black, Flat Black, Carbon



CARBON
WITH SMOKE SHIELD

Tri Composite

CODE: **GBD** SIZE: **XS - XXL**

Carbon Fiber

CODE: **GBD** SIZE: **XS - XXL**

REPLACEMENT SHIELDS GB SERIES

EXTERIOR SHIELDS

CODE:	COLOR:
GBCSE	CLEAR
GBLSSE	LIGHT SMOKE
GBDSSE	SMOKE
GBASE	AMBER
GBISE	IRIDIUM
GBMSE	MIRROR
GBGSE	GOLD MIRROR

INTERIOR SHIELDS

CODE:	COLOR:
GBCSI	CLEAR
GBLSSI	LIGHT SMOKE
GBDSSI	SMOKE
GBASI	AMBER

*Motorcycle Helmets shown with optional shields.
All helmets shipped with clear shield.*



GHOST BANDIT REVOLT
WITH SMOKE SHIELD



ADDITIONAL COLORS
GLOSS BLACK
WITH IRIDIUM SHIELD



WHITE
WITH MIRROR SHIELD



FLAT BLACK
WITH SMOKE SHIELD



SIMPSON MOTORCYCLE HELMETS

OUTLAW BANDIT

FEATURES

Chin air ram duct for improved air circulation, reduced lift counter measures DOT and Snell M2015

COLORS

White, Gloss Black, Flat Black, Gunmetal and Candee

NEW CANDEE
WITH SMOKE SHIELD



Fiberglass

CODE: **28315** SIZE: **XS - XXL**

REPLACEMENT SHIELDS 89200 SERIES

Helmet size specific

CODE:	COLOR:
89200M	CLEAR
89201M	SMOKE
89202M	AMBER
89203M	IRIDIUM
89204M	MIRROR
89206M	GOLD MIRROR

Replacement Pivot Kits

CODE: **99011**

Motorcycle Helmets shown with optional shields.
All helmets shipped with clear shield.

ADDITIONAL COLORS
GUNMETAL WITH GOLD SHIELD



WHITE



FLAT BLACK



GLOSS BLACK



STREET BANDIT

The Street Bandit Motorcycle Helmet is one of our best-selling helmets.

FEATURES

DOT and Snell M2015
Classic Bandit look for the motorcycle rider
The Street Bandit features an enlarged eye port area for excellent field of vision
Chin air ram duct vents
Top vents with shutoff option

COLORS

White, Gloss Black and Flat Black

FLAT BLACK



Fiberglass

CODE: **MSB15** SIZE: **XS - XXL**

REPLACEMENT SHIELDS 86030 SERIES

CODE:	COLOR:
86030M	CLEAR
86031M	DARK SMOKE
86032M	AMBER
86033M	IRIDIUM
86034M	MIRROR

Replacement Pivot Kits

CODE: **99017**

Motorcycle Helmets shown with optional shields.
All helmets shipped with clear shield.

ADDITIONAL COLORS
WHITE
HELMET SHOWN WITH IRIDIUM SHIELD



GLOSS BLACK
HELMET SHOWN WITH SMOKE SHIELD



HERITAGE COLLECTION

Heritage Collection helmets are re-creations of 1970s model Simpson helmets that have vintage fit, function and style, but meet modern DOT safety requirements.

M30

Classic Simpson M30 styling.

FEATURES

Cool Max[®] lined fabric moves moisture away from your body, keeping you cool and comfortable

DOT Rated

“Free Stop” pivot system allows the wearer to stop the shield at any angle

Additional cheek pads available

Approximate weight of Carbon

versions – 2.5 pounds

Approximate weight of non-Carbon

versions – 3.0 pounds

COLORS

White, Gloss Black, Flat Black and Gloss Carbon, Satin Carbon



SHOWN WITH OPTIONAL IRIDIUM SHIELD

Fiberglass

CODE:
M30D

SIZE:
XS - XL

Carbon Fiber

CODE:
M30D

SIZE:
XS - XL

REPLACEMENT SHIELDS M30 SERIES

CODE:
M30CS
M30LSS
M30DSS
M30LRS
M30LCS

COLOR:
CLEAR
LIGHT SMOKE
DARK SMOKE
LIGHT IRIDIUM
LIGHT CHROME

Replacement Pivot Kits

CODE:
M30PK



M50

The M50 Moto from the 70s is reborn in a sleek helmet with a nod to vintage, backed by over 50 years of Simpson technology. DOT Rated. The M50 includes a five-snap visor. See photo.

Additional cheek pads available

COLORS

White, Gloss Black and Flat Black, Flat Gunmetal, Red and Yellow



GLOSS BLACK

Fiberglass

CODE:
M50D

SIZE:
XS - XL

ADDITIONAL VISOR

CODE:
M50VISOR



VARIOUS GOGGLE COLORS AND MODELS AVAILABLE



ADDITIONAL COLORS
WHITE



RED



YELLOW



FLAT GUNMETAL



STRAP IN TO WIN



HEAD RESTRAINTS



HEAD RESTRAINTS

WHAT YOU NEED TO KNOW

Why do I need a frontal head restraint system?

Quite simply, head restraints save racers' lives!

If you are unfortunate enough to be involved in an accident during a race, your seatbelt is likely going to do its job and stop your body from moving forward. The head restraint will do its job and stop your head from whipping forward and placing enormous strain on your neck. A racer's head is made heavier than normal by the added weight of a helmet. Frontal impact in a race car can cause basilar skull fractures which are often fatal and have taken the lives of some of history's greatest racers. Keep in mind that it isn't necessarily how fast you are going but how fast you stop that causes some of the worst injuries.

What is the difference between the different head restraint devices?

Simpson offers a complete line of HANS Devices and Simpson Hybrids. The HANS is a yoke style head restraint and has a loyal following worldwide. The Hybrid is a backpack style device designed to stay with the racer upon entering or exiting the racecar. The Hybrid line features the Hybrid S, the only head restraint in the world that is tested and proven to work with 3-point OEM seatbelts, a plus for HPDE and Track Day participants. The HANS and Hybrids are popular with top level NASCAR, NHRA and WRC drivers. The difference in head restraint models comes down to weight – all HANS and Hybrid head restraints offer the same exceptional level of protection. We offer composite and carbon fiber models to service every price level. Simpson has historically worked to lower the price on head restraints to make this crucial piece of safety equipment affordable to all racers.

Do I need to use a specific seatbelt harness?

No, but the configuration of the seatbelt harness is critical and some head restraints are tailored for use with a FHR-specific seatbelt harness.

The shoulder strap mounting points should be even with the shoulders such that the straps make an angle of 10° to the horizontal.

The mounting points must be equally disposed about the user's centreline so that straps spread inward slightly from the mountings and around the FHRs.

This helps to keep the straps firmly engaged with the FHRs.

How do I care for my head restraint?

HANS and Hybrid head restraints are low maintenance but should be kept clean and dry.

Extreme hot or cold environments should be avoided, and they should be kept away from petroleum products and other corrosives which can affect even the strongest composite materials and resins. Store out of direct sunlight and clean when needed with soapy warm water.



Restraint System Mounting Zones (Side View)

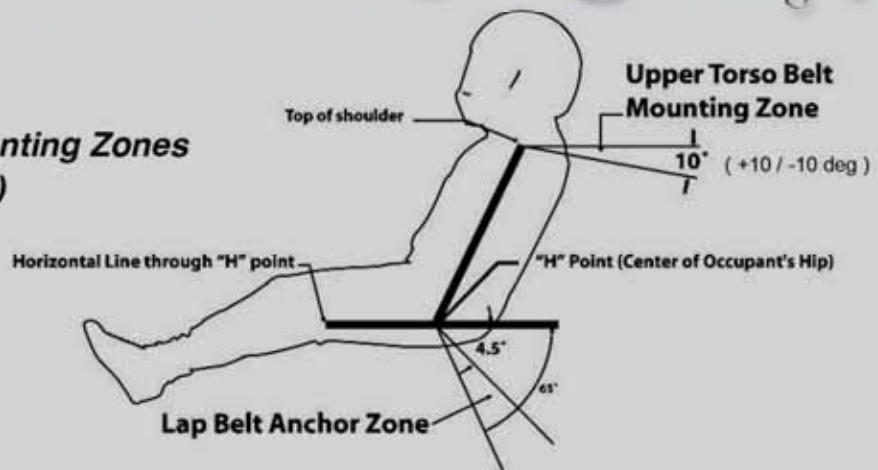

HEAD RESTRAINTS

HYBRID PRO LITE

The Hybrid Pro Lite® is the ultimate in safety and comfort. The Hybrid Pro Lite's new lightweight design and carbon fiber construction provides maximum comfort and maneuverability with superior strength. All of Simpson's Hybrid Series head restraints are designed for easily exiting the car without the danger of being entangled in other gear by offering the lowest profile of any comparable device. This device comes with optional patented SAS (Seatbelt Anchor System) for even greater coverage in flips, barrel rolls and side impacts. When the worst happens, you'll have the same great protection every time.

SHOWN WITH
M6 ANCHOR OPTION



ALEC HOHNADSELL,
FORMULA DRIFT DRIVER, HUDDY RACING



CODE: **HYPL** SIZE: **XS-XL**

CODE: **HYPL** SIZE: **XS-XL W/ SAS**

FEATURES
Ships race ready with Quick release and D-ring Helmet Anchors

UPGRADES
Post Anchors/ Tether Kit
M61 Quick Release/Dual End Tether Kit
Seatbelt Anchor System
Quick Click Anchors/Tether Kit



HYBRID PRO X PACKAGE

NHRA TOP FUEL AND FUNNY CAR

The Hybrid X package is designed for drag racing's extreme speeds and includes the Hybrid Pro Head Restraint with SAS, specially fitted with the double chin strap "W" style and a semi-rigid neck collar constructed of SFI 45.2 approved padding. The X package provides extreme protection and support and features six tethers connecting to 4 points on the helmet. The Hybrid Pro with X package is worn by top NHRA racers, including John Force and Robert Hight. Includes a Hybrid Pro, double chin strap and semi-rigid neck collar.

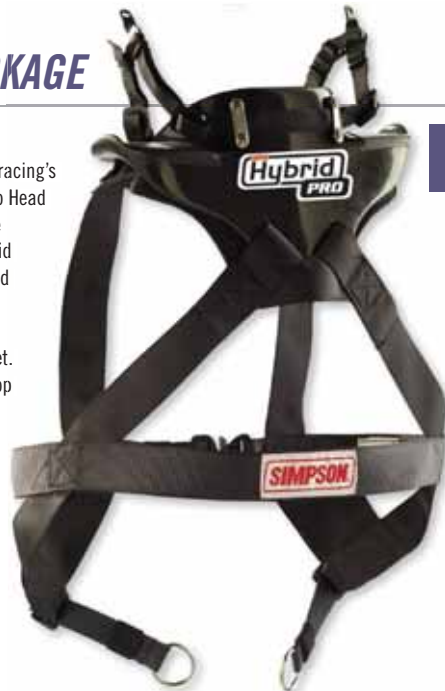

CODE: **HR.X.PKG** SIZE: **XS-XL, CUSTOM AVAILABLE**

UPGRADE
Quick Click Anchors/Tether Kit
Post Anchors/Tether Kit
M61 Quick Release/Dual End Tether Kit



SEMI-RIGID NECK COLLAR



DOUBLE CHIN STRAP

HYBRID SPORT

The Hybrid Sport® is a great head restraint device for those racing on a budget. The Hybrid Sport with its new lightweight design and DuPont® carbon/polymer construction provides maximum comfort and maneuverability with superior strength. All of Simpson's Hybrid Series head restraints are designed for easily exiting the car without the danger of being entangled in other gear by offering the lowest profile of any comparable device. This device comes with optional patented SAS (Seatbelt Anchor System) for even greater coverage in flips, barrel rolls and side impacts. When the worst happens, you'll have the same great protection every time.



CODE: **HS** SIZE: **XS-XL**

CODE: **HS** SIZE: **XS-XL W/ SAS**

FEATURES

Ships race ready with Quick release and D-ring Helmet Anchors

UPGRADES

Post Anchors/Tether Kit
M61 Quick Release/Dual End Tether Kit
Seatbelt Anchor System
Quick Click Anchors/Tether Kit

SHOWN WITH
M6 ANCHOR OPTION

HYBRID SPORT YOUTH

The Hybrid Sport® Jr. sizes give you all the safety as an Adult version, but 25% smaller to fit a Youth as young as 4 years. The Hybrid Sport with its lightweight design and DuPont® carbon/polymer construction provides maximum comfort and maneuverability with superior strength. All of Simpson's Hybrid Series head restraints are designed for easily exiting the car without the danger of being entangled in other gear by offering the lowest profile of any comparable device. This device comes with optional patented SAS (Seatbelt Anchor System) for even greater coverage in flips, barrel rolls and side impacts. When the worst happens, you'll have the same great protection every time.



Hybrid Sport Youth

CODE	FITS		
HS.XSC	XS/CHILD	22-26"	4-6 YEARS
HS.CHD	CHILD	22-26"	7-9 YEARS
HS.YTH	YOUTH	26-30"	9-12 YEARS

FEATURES

Ships race ready with Quick release and D-ring Helmet Anchors. Hybrid Sport Jr. Sizes come with Fixed-length back tethers:
XSC: 10" | CHD: 11" | Youth: 12"

UPGRADES

Post Anchors/ Tether Kit
M61 Quick Release/Dual End Tether Kit
Seatbelt Anchor System
Quick Click Anchors/Tether Kit

RECOMMENDED FOR
QUARTER MIDGET RACING

HEAD RESTRAINTS

SIMPSON Hybrid S HOT PRODUCT



Simpson's Hybrid S model is currently the only Frontal Head Restraint proven effective for 3-point harnesses, and the device is also FIA and SFI approved. Additionally, in a partnership with Detroit auto manufacturers, the Hybrid S is third party tested to FMVSS208.

The Hybrid S allows high-performance driving Instructors, auto manufacturing test engineers, and other drivers with 3-point harnesses access to the advantages of head restraint safety.

The FIA Hybrid Head Restraint, in conjunction with a Snell or FIA rated helmet and a 3-point harness, reduced neck tension significantly when compared to a test with only a helmet and 3-point harness.

While we can offer head restraint protection for use with 3-point seatbelts, Simpson's top concern is driver and instructor safety. We suggest a Full Containment Cockpit System that includes a Full Containment Seat, Snell or FIA rated Helmet, FIA or SFI approved Frontal Head Restraint, and a 5 to 7-point seatbelt harness system for the best protection while on the track.

FEATURES

- FIA approved, SFI certified
- High-quality carbon fiber construction
- Low profile. No high back to hook on the bars on exit.
- Multiple load paths to dissipate head loads
- Buckle attachment in front. No bulky straps underneath.
- Ships race ready with post clips
- Seat belt anchor system
- Helmet anchors available for upgrade

Hybrid S

CODE HYS.PA	FITS POST ANCHORS, ALL SIZES, W/O HELMET ANCHORS
HYS.M61	M61 UPGRADE OPTION, ALL SIZES, WITH HELMET ANCHORS



3 Point OEM
Harness Compatible

PROTECTION STATEMENT *Simpson's top concern is your safety. For your BEST protection on the racetrack, we suggest a full containment cockpit system that includes a full containment seat, Snell or FIA rated helmet, SFI or FIA approved head restraint and a 5, 6 or 7-point harness system.*

For best safety practices, it is our recommendation that no one should unhook/disable the airbag system installed by the auto manufacturer or their authorized installer. Our outside experts in Detroit confirmed and require their test engineers to use the Hybrid S in conjunction with the airbag in a 3-point system. All of our experts believe the airbag and Hybrid S work in conjunction to increase protection in frontal crash events.

OPTIONAL HELMET ACCESSORIES AND TETHERS FOR SIMPSON HYBRID

M61 DUAL END FITTING TETHER-PAIR

Used with M6 Anchor System.

CODE:
HS.M61.DE



HYBRID POST CLIPS-PAIR

CODE:
HS.PA
HY.PA



QUICK RELEASE ASSEMBLY

Used with D rings.

CODE:
HS.QR (1 SIDE)
HY.QR (1 SIDE)



HY QUICK CLICK LOOP

CODE:
HS.QC
HY.QC



ADJUSTABLE SLIDING TETHER

Used with Simpson Head Restraints.

CODE:
HR.STK.L



OPTIONAL HELMET ANCHOR

M6 ANCHOR

CODE:
M61.HAK
M61.HAK.SAH W/O WASHERS



SIMPSON POST ANCHORS PAIR

CODE:
PA.HAK
PA.HAK.SAH W/O WASHERS



D-RINGS

CODE:
SF1.DRK
SF1.DRK.SAH



SIMPSON QUICK CLICK SYSTEM

CODE:
QC.HAK
QC.HAK.SAH W/O WASHERS



HEAD RESTRAINTS

HYBRID SIZING CHART

CHEST STRAP WITH DRIVING SUIT ON

HOW TO MEASURE

1. Measure around chest below pectoral muscles.
2. Measure with driving suit. If not available add 1" to measurement.
3. Take measurement with tape placed against driver without any slack and without pulling the tape tight.
4. Once measurement has been determined, refer to size charts to device size selection.

HYBRID SIZE CHART

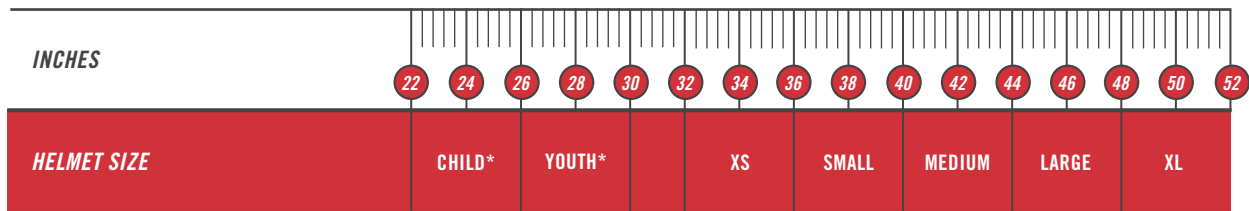

* CHILD AND YOUTH SIZES AVAILABLE IN HYBRID SPORT

HANS DEVICE SIZING CHART

Neck size is the starting point for fitting a HANS Device.
You may fit several sizes – comfort is the deciding factor. See HANS selection, beginning page 37.

HANS SIZE CHART

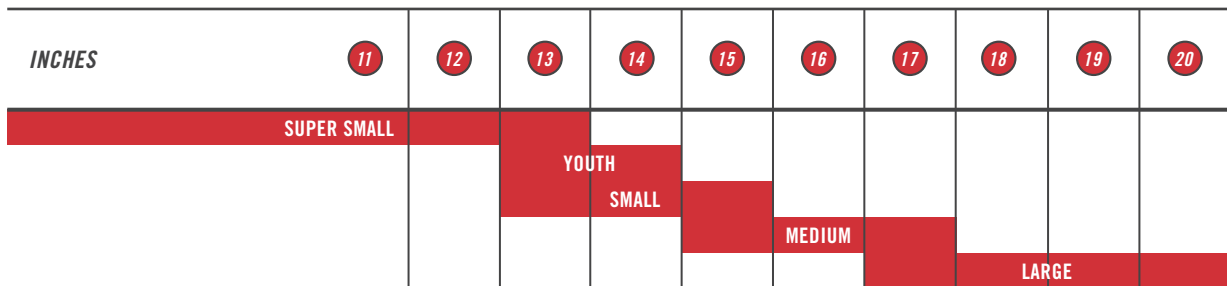



HANS III



The HANS III represents the third generation of injection molded HANS devices and takes a revolutionary approach to reducing weight. Using an all-new design and polymer, the HANS III features a hollow collar to substantially minimize weight. Engineered reinforcements ensure this HANS offers the same level of safety as every HANS device, while the reduced mass guarantees the lightest, most comfortable injection molded HANS ever. Call for FIA pricing.

Hans III

CODE	SIZE
DK 14237.311 SFI	20 MEDIUM, PA SLIDING SAH, SFI
DK 14237.321 SFI	20 MEDIUM, PA SLIDING, SFI
DK 14237.411 SFI	20 MEDIUM, QUICK CLICK, SAH, SFI
DK 14237.421 SFI	20 MEDIUM, QUICK CLICK, SLIDING, SFI
DK 14247.311 SFI	20 LARGE, PA SLIDING SAH, SFI
DK 14247.321 SFI	20 LARGE, PA SLIDING, SFI
DK 14247.411 SFI	20 LARGE, QUICK CLICK, SAH, SFI
DK 14247.421 SFI	20 LARGE, QUICK CLICK, SLIDING, SFI

FOR LAYDOWN CARS

DK 18337.311 SFI	30 MEDIUM, PA SLIDING, SAH, SFI
DK 18337.321 SFI	30 MEDIUM, PA SLIDING, SA, SFI
DK 18337.411 SFI	30 MEDIUM, QUICK CLICK, SLIDING, SAH, SFI
DK 18337.421 SFI	30 MEDIUM, QUICK CLICK, SLIDING, SA, SFI
DK 18347.311 SFI	30 LARGE, PA SLIDING, SAH, SFI
DK 18347.321 SFI	30 LARGE, PA SLIDING, SA, SFI
DK 18347.411 SFI	30 LARGE, QUICK CLICK, SLIDING, SAH, SFI
DK 18347.421 SFI	30 LARGE, QUICK CLICK, SLIDING, SA, SFI

HANS PRO ULTRA

NASCAR APPROVED

The HANS Pro Ultra is SFI 38.1 and NASCAR approved. The Pro Ultra device applies lightweight construction of the Carbon Fiber Pro series to the modern new shape of the Sport II. The Ultra saves on weight and allows for easy entry and exit from the race car, even smaller, tighter vehicles. The 100% carbon fiber construction features a hollow core for increased weight reduction without sacrificing strength. The sliding tethers offer exceptional visibility. Upgrade to the Pro Ultra today.



Hans Pro Ultra

CODE	SIZE
DK 13235.31 SFI	20M PRO ULTRA, PA SLIDING FOR SAH HELMET, SFI
DK 13235.32 SFI	20M PRO ULTRA, PA SLIDING FOR SA HELMET, SFI
DK 13235.41 SFI	20M PRO ULTRA, QC SLIDING FOR SAH HELMET, SFI
DK 13235.42 SFI	20M PRO ULTRA, QC SLIDING FOR SA HELMET, SFI
DK 13245.31 SFI	20L PRO ULTRA, PA SLIDING FOR SAH HELMET, SFI
DK 13245.32 SFI	20L PRO ULTRA, PA SLIDING FOR SA HELMET, SFI
DK 13245.41 SFI	20L PRO ULTRA, QC SLIDING FOR SAH HELMET, SFI
DK 13245.42 SFI	20L PRO ULTRA, QC SLIDING FOR SA HELMET, SFI

FOR LAYDOWN CARS

DK 13335.31 SFI	30M, PRO ULTRA, PA SLIDING FOR SAH HELMET, SFI
DK 13335.32 SFI	30M, PRO ULTRA, PA SLIDING FOR SA HELMET, SFI
DK 13335.41 SFI	30M, PRO ULTRA, QC SLIDING FOR SAH HELMET, SFI
DK 13335.42 SFI	30M, PRO ULTRA, QC SLIDING FOR SA HELMET, SFI

YOUTH HANS III



The lightweight HANS III is now available in a Youth size. The SFI 38.1 certified HANS III Youth features a hollow collar that substantially minimizes weight and is engineered for the growing young racer. Reinforcements ensure an exceptionally strong structure that provides the same level of safety as every HANS device.

See sizing chart for recommendations – remember driver comfort is the most important factor when choosing a size.

Youth Hans III

CODE	SIZE
DK 16217.311 SFI	20, PA SLIDING FOR SAH, SFI
DK 16217.321 SFI	20, PA SLIDING FOR SA, SFI
DK 16217.411 SFI	20, QC SLIDING FOR SAH, SFI
DK 16217.421 SFI	20, QC SLIDING FOR SA, SFI

HEAD RESTRAINTS



HANS ADJUSTABLE SERIES



This head and neck restraint from HANS promises to be a great addition to the head restraint market with an adjustable feature for those racers who want a customized comfort level. Call for FIA pricing.



Hans Adjustable Series

CODE	SIZE
DK 13034.32 SFI	MEDIUM ADJUSTABLE DEVICE WITH SLIDING TETHERS & PROF. POST ANCHORS
DK 13034.42 SFI	MEDIUM ADJUSTABLE DEVICE WITH SLIDING TETHERS & QUICK CLICK ANCHORS

FEATURES

Device adjusts in 5 degree increments, from 10 to 40 degrees
Fits all types of race cars and seats
Ships with complete instructions plus tools to adjust device

HANS PRO ULTRA LITE



The HANS Pro Ultra Lite is SFI 38.1 and FIA approved. The Pro Ultra device applies aerospace grade carbon to achieve a 100+ gram weight saving compared to the regular Ultra. The Ultra Lite saves on weight and allows for easy entry and exit from the race car, even smaller, tighter vehicles. The 100% carbon fiber construction features a hollow core for increased weight reduction without sacrificing strength. The sliding tethers offer exceptional visibility. Call for FIA pricing. Upgrade to the Pro Ultra Lite today.



HANS Pro Ultra Lite

CODE	SIZE
DK 14236.31 SFI	20M, PA SLIDING FOR SAH HELMET, SFI
DK 14236.32 SFI	20M, PA SLIDING FOR SA HELMET, SFI
DK 14236.41 SFI	20M, QC SLIDING FOR SAH HELMET, SFI
DK 14236.42 SFI	20M, QC SLIDING FOR SA HELMET, SFI
DK 14246.31 SFI	20L, PA SLIDING FOR SAH HELMET, SFI
DK 14246.32 SFI	20L, PA SLIDING FOR SA HELMET, SFI
DK 14246.41 SFI	20L, QC SLIDING FOR SAH HELMET, SFI
DK 14246.42 SFI	20L, QC SLIDING FOR SA HELMET, SFI

FOR LAYDOWN CARS

DK 16336.31 SFI	30M, PA SLIDING FOR SAH HELMET, SFI
DK 16336.32 SFI	30M, PA SLIDING FOR SA HELMET, SFI
DK 16336.41 SFI	30M, QC SLIDING FOR SAH HELMET, SFI
DK 16336.42 SFI	30M, QC SLIDING FOR SA HELMET, SFI

HOT NEW PRODUCT HANS ZERO



The Stilo HANS Zero combines the best of the Simpson Group, a fresh Italian design engineered for extreme lightness along with HANS proven technology to create the lightest, most comfortable HANS device ever. Using proprietary techniques and aerospace grade carbon fiber, the Stilo HANS Zero is 15% lighter than the HANS Ultra Lite, the current lightest HANS on the market. The Zero's legs are carefully crafted to fit your chest and the result is pure comfort! You will know you're wearing the best head and neck protection available.

Stilo HANS Zero is the ultimate achievement from the company that invented head and neck restraints, a collaboration of excellence combining Stilo's best of Italian style and HANS lifesaving technology.



PRODUCT AVAILABLE EARLY 2019

HANS PROFESSIONAL SERIES NASCAR APPROVED



Professional HANS devices are lightweight handlaid carbon fiber. The HANS Professional device is worn by professional racers worldwide, including NASCAR's finest racers like Jimmie Johnson, Tony Stewart and Denny Hamlin. Call for FIA pricing.

FEATURES

The Model 20, our most popular angle, fits upright seats like those found in most sports cars, from Honda to Lamborghini. Fits most stock cars, drag cars, sprints, modifieds and similar. Available in 4 sizes – Super Small (youth), Small, Medium, Large.

The Model 10 fits extreme upright seats like those found in sprint cars. It also is comfortable for some very thin drivers. Model 10 available in size Medium only.

The Model 30 fits laydown seats like some Formula cars. It also is comfortable for larger drivers in sports cars in place of a Model 20. Available in size Large only.

The Model 40 – special order for vintage single seaters only. Available in size Medium only.



Hans Professional Series

CODE	SIZE
DK 11211.321 SFI	SUPER SMALL 20 PRO, PA SLIDING
DK 11211.421 SFI	SUPER SMALL 20 PRO, QUICK CLICK SLIDING
DK 11221.321 SFI	SMALL 20 PRO, PA, SLIDING
DK 11221.421 SFI	SMALL 20 PRO, QUICK CLICK, SLIDING
DK 11131.321 SFI	MEDIUM 10 PRO, PA, SLIDING
DK 11131.421 SFI	MEDIUM 10 PRO, QUICK CLICK SLIDING
DK 11231.321 SFI	MEDIUM 20 PRO, PA, SLIDING
DK 11231.421 SFI	MEDIUM 20 PRO, QUICK CLICK
DK 11431.321 SFI	MEDIUM 40 PRO
DK 11241.321 SFI	LARGE 20 PRO, PA, SLIDING
DK 11241.421 SFI	LARGE 20 PRO, QUICK CLICK, SLIDING
DK 11341.321 SFI	LARGE 30 PRO, PA, SLIDING
DK 11341.421 SFI	LARGE 30 PRO, QUICK CLICK, SLIDING

HEAD RESTRAINTS

HANS ACCESSORIES

POST COLLAR ANCHOR

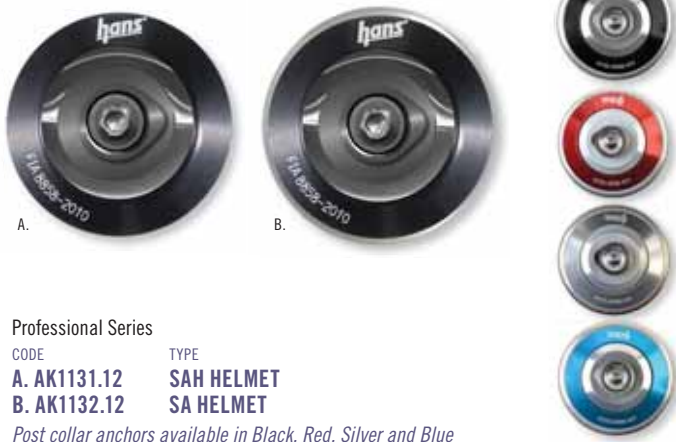

Professional Series

CODE TYPE
A. AK1131.12 SAH HELMET
B. AK1132.12 SA HELMET

Post collar anchors available in Black, Red, Silver and Blue

M61 SINGLE END FITTING TETHER-PAIR

Used with M6 Anchor System

CODE Type
TK1451.3 SPORT II
TK1451.4 ADJUSTABLE, PRO ULTRA, PROFESSIONAL, SPORT 1
TK1451.7 HANS III



QUICK CLICK ATTACHMENT

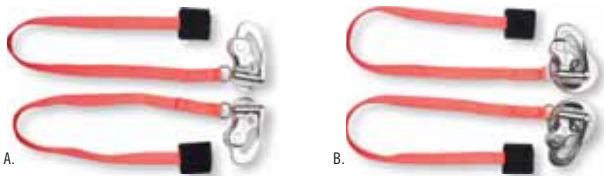

CODE TYPE
A. AK1141.2 FITS SAH HELMET WITHOUT NUT WASHERS
B. AK1142.2 FITS SA HELMET

M6 ANCHOR



CODE
M61.HAK
M61.HAK.SAH, WO WASHERS

SLIDING TETHER FOR POST COLLAR ANCHOR



CODE TYPE
TK1131.3 SPORT II
TK1231.4 ADJUSTABLE, PRO ULTRA, PROFESSIONAL AND SPORT 1 (Shown)
TK1431.7 HANS III

SLIDING TETHER FOR QUICK-CLICK ANCHOR



CODE TYPE
TK1141.3 SPORT II
TK1241.4 ADJUSTABLE, PRO ULTRA, PROFESSIONAL AND SPORT 1 (Shown)
TK1441.7 HANS III

PADDING



CODE TYPE
K9 GEL KIT
K9 FOAM KIT
 Colors: Black, Blue, Red, Yellow

HANS BAG

Preformed bag protects your HANS from sunlight and scuffing

CODE TYPE
23909 HANS BAG



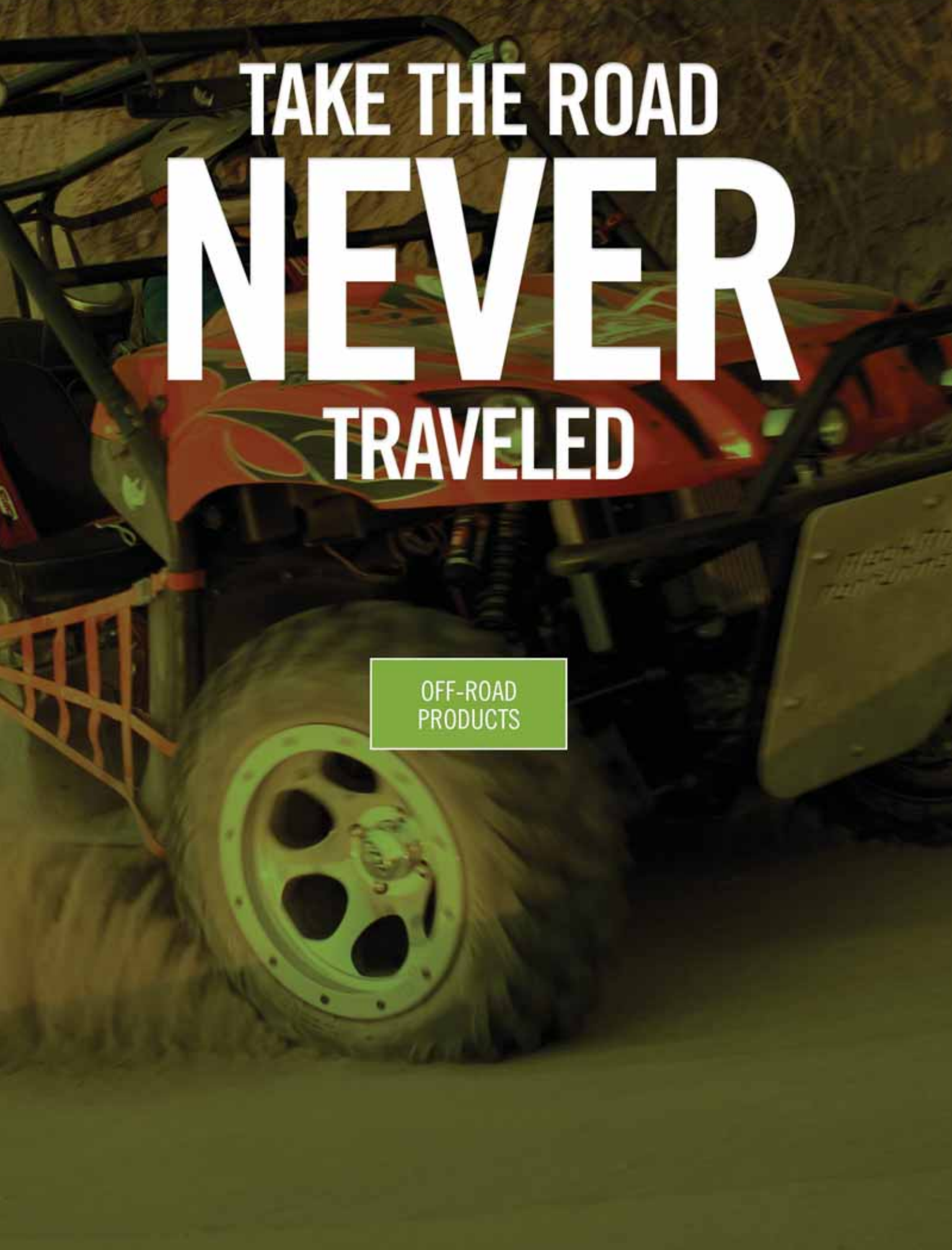

**TAKE THE ROAD
NEVER
TRAVELED**

OFF-ROAD
PRODUCTS

OFF-ROAD PRODUCTS



UTV SPORT STYLE SUIT



UTV Suit features our popular 3 stripe retro styling
 One-piece suit meets and exceeds SFI 3.2A/1 and SFI 5 3.2/5 requirements
 Black Ankle and Wrist Cuffs
 Standard Shoulder Epaulets
 Red, Orange and Yellow racing stripes on driving suit arms

SIZES

Small – XXLarge, 15% upcharge for XXL

COLOR

Black Only

CODE: **U3** SIZE: **SFI 3.2/1 RATED**

CODE: **U4** SIZE: **SFI 3.2/5 RATED**



NEW DESERT DEVIL

The Desert Devil Off-Road Helmet System includes our popular Devil Ray Snell SA 2015 rated helmet, equipped with an offset top air pipe and off-road communication kit. Pop the helmet out of the box and you are ready to go riding.

The off-road communications kit comes with a 3.5mm headphone connection that can be plugged into your mobile phone for music using an auxiliary cord easily purchased from your favorite electronics store. The offset top air pipe gives extra head clearance in the vehicle.



CODE: **682** TYPE: **WHITE, GLOSS BLACK** SIZE: **XS-XXL**

CODE: **682** TYPE: **CARBON FIBER** SIZE: **XS-XXL**

RECOMMENDED FOR REPLACEMENT SHIELDS 84300 SERIES

	CODE:	COLOR:
Circle Track	84300A	CLEAR
Dirt Track	84301A	SMOKE
Off-Road	84303	IRIDIUM
Road Racing	84304A	AMBER
	84306A	MIRROR

COLORS

White, Gloss Black, and Carbon fiber



VORTEX

The Vortex seat provides high containment while still allowing for easy entry and exit with its cutaway lower bolster design. It is designed to work with the factory slider without raising the seat height. The Vortex's traditional tube-style frame is mated to a laser cut seat base which utilizes a variety of different modular mounting rails. Optional seat heaters and adjustable lumbar supports are available.

The Vortex model is available in 3 sizes:

1. Standard size
2. Wide Body (2" wider tail)
3. Short Cushion (the base is 2" shorter front to back)



BLACK/RED

Vortex

CODE	TYPE
101-304	VORTEX BLACK/BLACK
101-305	VORTEX BLACK/CHARCOAL
101-306	VORTEX BLACK/RED
101-308	VORTEX BLACK/ORANGE
101-317	VORTEX BLACK/LT BLUE
101-CUS	VORTEX CUSTOM

*THE VORTEX MODULAR DESIGN FITS SEVERAL VEHICLES. MOUNTS ARE NOT INCLUDED AND MUST BE PURCHASED SEPARATELY. SEE PAGE 50.

SEAT MEASUREMENTS ARE LOCATED ON PAGE 51



CUSTOM
VORTEX

SPECIAL EDITION BLACKOUT VORTEX



BLACK/LT BLUE



BLACK/CHARCOAL



BLACK/ORANGE

VORTEX REAR BENCH



The Vortex rear bench is completely bolt-in. It does not require any cutting or permanent modifications to install and utilizes a laser cut panel to replace the factory plastic console. The rear bench matches the styling of the new Vortex and can be ordered in colors that complement the factory front seat for those who do not want to replace the OEM front seats. Optional seat heaters and adjustable lumbar supports are available.



Vortex Rear Bench

CODE	TYPE
116-510-305	VORTEX REAR BENCH BLACK/CHARCOAL
116-510-306	VORTEX REAR BENCH BLACK/RED
116-510-307	VORTEX REAR BENCH BLACK/BLUE
116-510-308	VORTEX REAR BENCH BLACK/ORANGE
116-510-309	VORTEX REAR BENCH BLACK/SILVER
116-510-316	VORTEX REAR BENCH BLACK/WHITE
116-510-317	VORTEX REAR BENCH BLACK/LT BLUE
116-510-CUS	VORTEX REAR BENCH CUSTOM

*ABOVE PART NUMBERS FIT XP 4 1000, XP 4 TURBO, 2015 + XP 4 900

**ALSO AVAILABLE FOR 2010-2014 RZR 4 800/900

SEAT MEASUREMENTS ARE LOCATED ON PAGE 51

CAN AM X3 VORTEX BENCH



The new Can Am X3 Vortex bench is 4" wider than our standard Vortex bench, making it the perfect size for the X3. All Vortex rear benches are completely bolt-in and come with all the required hardware needed for installation. It can be ordered in colors that complement the factory front seat for those who do not want to replace the OEM front seats.



Can Am X3 Vortex Bench

CODE	TYPE
303-510-304	VORTEX REAR BENCH BLACK/BLACK
303-510-305	VORTEX REAR BENCH BLACK/CHARCOAL
303-510-306	VORTEX REAR BENCH BLACK/RED
303-510-308	VORTEX REAR BENCH BLACK/ORANGE
303-510-317	VORTEX REAR BENCH BLACK/LT BLUE
303-510-303	VORTEX REAR BENCH BLACK/FIRE RED
303-510-CUS	VORTEX REAR BENCH CUSTOM

*ABOVE PART NUMBERS FIT XP 4 1000, XP 4 TURBO, 2015 + XP 4 900

**ALSO AVAILABLE FOR 2010-2014 RZR 4 800/900

SEAT MEASUREMENTS ARE LOCATED ON PAGE 51

CUSTOM
MATTE BLACK, CARBON FIBER BLACK
WITH FIRE RED ACCENTS



PRO SPORT

The Pro Sport was developed and engineered for superior fit, function, comfort and style all while keeping its mounting position as low as possible in the vehicle. The Pro Sport is 2" wider than our standard Vortex in key areas with extra broad shoulders for the ultimate comfort and containment. Its base is made up of our laser-cut universal pan design making it ideal for UTVs, Buggies, Jeeps and most all off-road vehicles. Optional seat heaters and adjustable lumbar supports are available.



BLACK/LT BLUE/GREY

Pro Sport

CODE	TYPE
106-304	PRO SPORT BLK/BLK
106-305	PRO SPORT BLK/CHAR/GREY
106-306	PRO SPORT BLK/RED/GREY
106-308	PRO SPORT BLK/ORG/GREY
106-317	PRO SPORT BLK/LT BLUE/GREY
106-CUS	PRO SPORT CUSTOM

*THE PRO SPORT MODULAR DESIGN FITS SEVERAL VEHICLES. MOUNTS ARE NOT INCLUDED AND MUST BE PURCHASED SEPARATELY. SEE PAGE 50.

SEAT MEASUREMENTS ARE LOCATED ON PAGE 51

CUSTOM PRO SPORT



SPECIAL EDITION BLACKOUT PRO SPORT



BLACK/RED/GREY



BLACK/ORANGE/GREY



BLACK/CHARCOAL/GREY

170 AGGRESSOR

ALL NEW RE-ENGINEERED DESIGN FOR IMPROVED PERFORMANCE

The 170 Aggressor has been engineered to provide superior containment in conjunction with a 5 point harness. It is available in three different color options or it can be customized to order in a wide variety of colors and materials to complement your car.



BLACK/LT BLUE/WHITE

170 Aggressor

CODE	TYPE
110-304	170 AGGRESSOR M BLACK/BLACK/C FIBER
110-305	170 AGGRESSOR M BLACK/GREY/WHITE/C FIBER
110-306	170 AGGRESSOR M BLACK/RED/WHITE/C FIBER
110-317	170 AGGRESSOR M BLACK/LT BLUE/WHITE/C FIBER
110-CUS	170 AGGRESSOR CUSTOM

*MOUNTS ARE NOT INCLUDED AND MUST BE PURCHASED SEPARATELY. SEE PAGE 50.

SEAT MEASUREMENTS ARE LOCATED ON PAGE 51



BLACK/RED/WHITE



BLACK/GREY/WHITE



CUSTOM COLORS

XL-R

The XL-R was designed with the Jeep daily driver in mind with its reclining backrest and easy exit/entry bolster design. The reclining function allows you to fine-tune the comfort level and provides easy backseat access. Like all of our seats, the XL-R is a suspension seat and is built with the highest quality materials. The XL-R adds comfort, safety and style to any ride.



CUSTOM COLORS

XL-R (Reclining Universal Tab Mounted)

CODE	TYPE
505-108-101	XL-R ALL MATTE BLACK
505-108-500	XL-R XCEL BLACK CLOTH/MATTE BLACK
505-108-105	XL-R MATTE BLACK/CARBON FIBER BLACK
505-108-106	XL-R MATTE BLACK/CARBON FIBER BLACK/RED
505-108-107	XL-R MATTE BLACK/CARBON FIBER BLACK/BLUE
505-108-108	XL-R MATTE BLACK/CARBON FIBER BLACK/ORANGE
505-108-109	XL-R MATTE BLACK/CARBON FIBER BLACK/CARBON FIBER SILVER
505-108-CUS	XL-R CUSTOM

SEAT MEASUREMENTS ARE LOCATED ON PAGE 51



MATTE BLACK



OFF-ROAD D3 RESTRAINT

The Simpson D3 buckle does what no other buckle system can. It provides the ease and convenience of a sewn-in harness without the shoulder straps being sewn to the lap belt. Its unique patented design eliminates the two shoulder strap links while still allowing the shoulder straps to be joined at the center of the buckle, truly emulating the "V" shape of a 5 point latch and link.

*To order a D3 harness with cadmium plated hardware, remove the "X" from the end of the part number. Shoulder speed adjusters are not available with cadmium plating.

Not SFI Rated.



D3

CODE	TYPE
3B22PIKX	2" BLACK WITH PADS
3B22PIRX	2" RED WITH PADS
3B22PIBX	2" BLUE WITH PADS
3B33PIKX	3" BLACK WITH PADS
3B33PIRX	3" RED WITH PADS
3B33PIBX	3" BLUE WITH PADS
3B22NIKX	2" BLACK NO PADS
3B22NIRX	2" RED NO PADS
3B22NIBX	2" BLUE NO PADS
3B33NIKX	3" BLACK NO PADS
3B33NIRX	3" RED NO PADS
3B33NIBX	3" BLUE NO PADS

ALSO AVAILABLE IN STANDARD LATCH AND LINK
CALL FOR PRICING

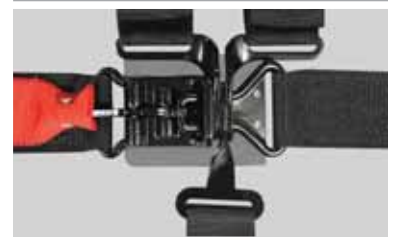

OFF-ROAD PRODUCTS

NEW RZR FRONT DOOR BAG SET

Simpson door bags add storage, style and function in just minutes. Its tone-on-tone hexagonal-printed, all-weather-resistant fabric is durable but subtle enough not to clash with your vehicle's color scheme.

FEATURES

- Reverse coil zippers protect contents from dust, dirt and moisture
- Reverse dust cover keeps dust and dirt from collection on zippers
- Expansive storage compartment with internal pockets
- Paneled construction allows for maximum storage
- Double-side coated fabric allows for easy cleaning inside and out
- Padded knee area
- (2) To Go Bags/Phone bags you can take with you

COLOR

Black

CODE:

ORBGRZRF18K

FITS:

2014 – 18 POLARIS RZR XP 1000/ALL TURBOS/XP 4 1000 TURBO 4 (FRONT DOORS ONLY)
2015 – 18 RZR 900XC/S900/4 900 FRONT ONLY/RZR S4 900

BAGS ONLY FIT OEM/STOCK DOORS



TO GO BAGS



OPEN



CLOSED

NEW UNIVERSAL CENTER CAB BAG

Our Universal Center Cab Bag will fit in most vehicles and can be easily removed and used as a small backpack. It's constructed using our durable tone-on-tone hexagonal-printed all-weather-resistant fabric.

FEATURES

- Reverse coil zippers protect contents from dust, dirt and moisture
- Reverse dust cover keeps dust and dirt from collection on zippers
- Expansive storage compartment with internal pockets
- Paneled construction allows for maximum storage
- Double-side coated fabric allows for easy cleaning inside and out

CODE:

ORBESH18K

COLOR

Black



THIS BAG IS DESIGNED TO BE EASILY REMOVED FROM YOUR VEHICLE AND USED AS A BACKPACK ONCE YOU HAVE ARRIVED AT YOUR DESTINATION.

NEW CAN AM X3 DOOR BAG SET

Simpson door bags add storage, style and function in just minutes. Designed using a super-durable hexagonal-printed, tone-on-tone, double-side coated black fabric, these bags add style to your ride without clashing with your vehicle's color scheme.

FEATURES

- Reverse coil zippers protect contents from dust, dirt and moisture
- Reverse dust cover keeps dust and dirt from collection on zippers
- Expansive storage compartment with internal pockets
- Paneled construction allows for maximum storage
- Double-side coated fabric allows for easy cleaning inside and out
- Padded knee protection
- (2) To Go Bags/Phone bags you can take with you

COLOR

Black

CODE:
ORBGCAP18K

BAGS ONLY FIT OEM/STOCK DOORS



OPEN



CLOSED



TO GO BAGS



SEAT MOUNTS



CODE	TYPE
115	POLARIS RZR 570/800/900/1000/TURBO (INCLUDING FRONT OF ALL RZR 4), GENERAL, RS1
115W	POLARIS RZR WIDE BODY & PRO SPORT MOUNT, FITS ALL ABOVE MODELS
116	POLARIS RZR REAR SEAT MOUNT 800/900/1000/ALL TURBOS, GENERAL 4
116W	POLARIS RZR REAR PRO SPORT SEAT MOUNT 800/900/1000/ALL TURBOS, GENERAL 4
110D	POLARIS 170 DRIVER MOUNT
110P	POLARIS 170 PASSENGER MOUNT

CODE	TYPE
303	CAN AM X3 STANDARD FRONT MOUNT
303L	CAN AM X3 1" LOWER FRONT MOUNT
304L	CAN AM X3 REAR MOUNT (2" SHORTER BASE FRONT TO BACK)
202D	YAMAHA YXZ DRIVER MOUNT
202P	YAMAHA YXZ PASSENGER MOUNT
270D	WILD CAT XX DRIVER MOUNT
270P	WILD CAT XX PASSENGER MOUNT

OTHER MODELS ARE AVAILABLE. CALL 310-325-6035 x122

YXZ DOOR LATCH PADS

CODE	TYPE
2021K	BLACK
2021G	GREY
2021R	RED
2021B	BLUE
2021O	ORANGE



YXZ LAP BELT MOUNTS

CODE	TYPE
2022	YXZ LAP BELT MOUNTS



POLARIS LAP BELT MOUNTS

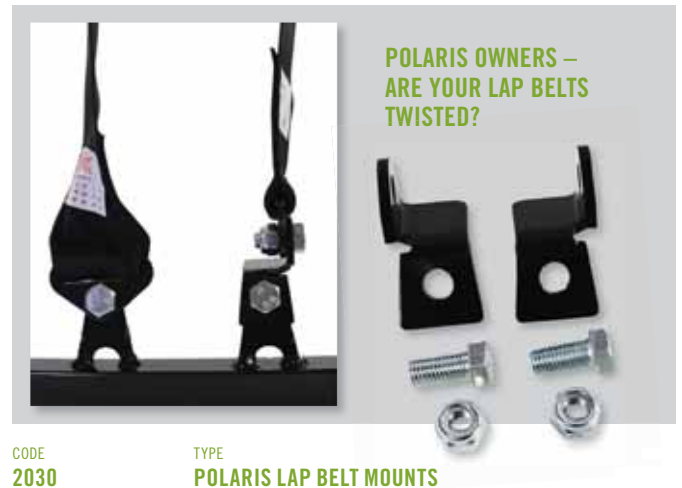

CODE	TYPE
2030	POLARIS LAP BELT MOUNTS

SEAT OPTIONS

CODE	TYPE
HEATER	SEAT HEATER
LUMBAR	ADJUSTABLE LUMBAR
POCKETFRT	FRONT POCKET
POCKETRR	REAR POCKET

CODE	TYPE
POCKETHYDRO	HYDRATION PACK POCKET
EXTRAWIDE	EXTRA WIDE
HEADREST	ADD HEADRESTS TO OFF-ROAD BENCH
DIAMOND	DIAMOND STITCH

SEAT MEASUREMENTS

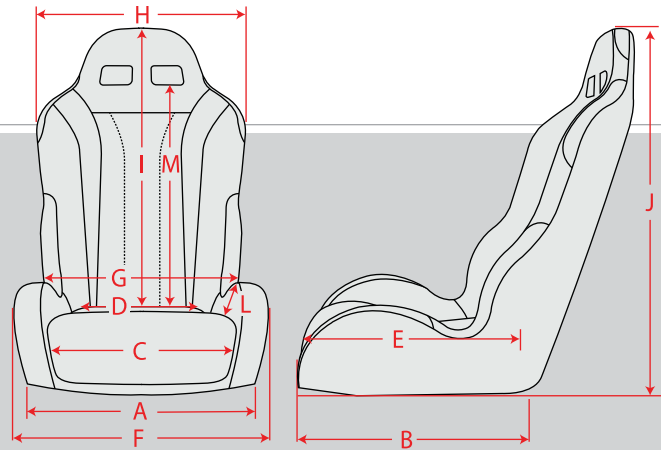

- A Base Width
- B Base Length
- C Cushion Width Front
- D Cushion Width Rear
- E Cushion Length
- F Overall Width Thigh
- G Overall Width Waist
- H Overall Width Shoulder
- I Back Height
- J Overall Height
- K Tabs/Rails
- L Bolster Height
- M Shoulder Slots

VORTEX

A Base Width	17"
B Base Length	21"
C Cushion Width Front	15"
D Cushion Width Rear	11"
E Cushion Length	20"
F Overall Width Thigh	20"
G Overall Width Waist	20"
H Overall Width Shoulder	21"
I Back Height	29"
J Overall Height	32.5"
K Tabs	Universal
L Bolster Height	4"
M Shoulder Slots	24"

Weight 23lb
Angle 75

WIDE BODY

A Base Width	18.5"
B Base Length	22"
C Cushion Width Front	17"
D Cushion Width Rear	11"
E Cushion Length	20.5"
F Overall Width Thigh	22"
G Overall Width Waist	20"
H Overall Width Shoulder	23"
I Back Height	29"
J Overall Height	32.5"
K Tabs	Universal
L Bolster Height	2"
M Shoulder Slots	24"

Weight 24lb
Angle 75

REAR

A Base Width	17"
B Base Length	19"
C Cushion Width Front	15"
D Cushion Width Rear	11"
E Cushion Length	17"
F Overall Width Thigh	20"
G Overall Width Waist	20"
H Overall Width Shoulder	21.5"
I Back Height	29"
J Overall Height	32.5"
K Tabs	Universal
L Bolster Height	4"
M Shoulder Slots	24"

Weight 19.5lb
Angle 75

BENCH

A Base Width	43.5"
B Base Length	19"
C Cushion Width Front	38.5"
D Cushion Width Rear	37"
E Cushion Length	18"
F Overall Width Thigh	44.75"
G Overall Width Waist	44"
H Overall Width Shoulder	45.5"
I Back Height	29"
J Overall Height	34.25"
K Tabs	10.875"
L Bolster Height	4.5"
M Shoulder Slots	23"

Weight 48lb
Angle 75

PRO SPORT

A Base Width	19.5"
B Base Length	22"
C Cushion Width Front	17"
D Cushion Width Rear	11"
E Cushion Length	20.5"
F Overall Width Thigh	23"
G Overall Width Waist	20"
H Overall Width Shoulder	23"
I Back Height	32.5"
J Overall Height	34"
K Tabs	Universal
L Bolster Height	3"
M Shoulder Slots	23"

Weight 24lb
Angle 75

170 AGGRESSOR

A Base Width	16"
B Base Length	17.5"
C Cushion Width Front	12.5"
D Cushion Width Rear	10"
E Cushion Length	15"
F Overall Width Thigh	17.5"
G Overall Width Waist	15.5"
H Overall Width Shoulder	19.5"
I Back Height	24"
J Overall Height	26"
K Tabs	Universal
L Bolster Height	2.5"
M Shoulder Slots	17.5"

Weight 16lb
Angle 73

TSR

A Base Width	15.5"
B Base Length	21.5"
C Cushion Width Front	15"
D Cushion Width Rear	11"
E Cushion Length	21"
F Overall Width Thigh	22.5"
G Overall Width Waist	22.25"
H Overall Width Shoulder	25"
I Back Height	31"
J Overall Height	34.5"
K Tabs	14" x 18"
L Bolster Height	5.25"
M Shoulder Slots	24"

Weight 27lb
Angle 75

PRO V2

A Base Width	15.5"
B Base Length	21.5"
C Cushion Width Front	14.5"
D Cushion Width Rear	11.5"
E Cushion Length	21"
F Overall Width Thigh	20.75"
G Overall Width Waist	21.75"
H Overall Width Shoulder	23"
I Back Height	30"
J Overall Height	34"
K Tabs	14" x 18"
L Bolster Height	8.5"
M Shoulder Slots	23"

Weight 22lb
Angle 75

XL-R

A Base Width	19"
B Base Length	22"
C Cushion Width Front	14"
D Cushion Width Rear	11.5"
E Cushion Length	19"
F Overall Width Thigh	21.25"
G Overall Width Waist	19.75"
H Overall Width Shoulder	21.5"
I Back Height	29.5"
J Overall Height	34"
K Tabs	14" x 18"
L Bolster Height	2"
M Shoulder Slots	23"

Weight 28lb
Angle Adjustable

REVOLVER

A Base Width	18.25"
B Base Length	20.5"
C Cushion Width Front	15"
D Cushion Width Rear	13"
E Cushion Length	19"
F Overall Width Thigh	22"
G Overall Width Waist	21.5"
H Overall Width Shoulder	22"
I Back Height	28"
J Overall Height	32.5"
K Rails	9"
L Bolster Height	3"
M Shoulder Slots	21"

Weight 21lb
Angle 73

APEX

A Base Width	16"
B Base Length	22"
C Cushion Width Front	13"
D Cushion Width Rear	10.5"
E Cushion Length	19"
F Overall Width Thigh	21.5"
G Overall Width Waist	22"
H Overall Width Shoulder	21.5"
I Back Height	29"
J Overall Height	31.75"
K Tabs	14" x 18"
L Bolster Height	5"
M Shoulder Slots	21"

Weight 17lb
Angle 77



PUT ON THE ADVANTAGE

RACING SUITS

SIMPSON FINANCING FOR RACERS

SEE PAGE 5 FOR APPLICATION

Racing can be a dangerous sport, and safety products often fall by the way when purchases for the car and entry fees are more critical. Simpson offers a finance program that helps to make safe racing affordable.

NOMEX® TECHNOLOGY RACE PROTECTION

DuPont™
Nomex®

PERFORMANCE & CONFIDENCE

Racing professionals can't have one without the other. That's why they wear racing suits made of DuPont™ Nomex® fiber. In fact, 95% of racers around the world trust the protection of Nomex® to keep them safe. It manages extreme heat, yet still delivers incredible comfort, style and durability – giving them the performance only Nomex® thermal technology can provide. Racing suits and apparel made of Nomex® fiber help play a pivotal role in providing the valuable seconds racing professionals need to escape fires that result from both on-track collisions and pit accidents.

BUILT IN

Racing gear made of Nomex® is inherently flame resistant; the FR (flame resistant) protection is built into the fiber and cannot be washed out or worn away – ever. It won't melt or combust when exposed to flame and actually becomes thicker when exposed to intense heat forming a protective barrier between the heat source and the skin.

TRUST

For more than 30 years, DuPont™ Nomex® has been the industry leader around the world in FR protection against the ever-present danger of fires at the racetrack.

95% of racers (NASCAR®, IRL, NHRA, WoO and IHRA) around the world, including their pit crews, rescue teams and track officials, trust and depend on the FR protection of racing suits made with DuPont™ Nomex®.

SUIT TESTING

THERMO-MAN® is the most advanced life-sized thermal burn injury evaluation system in the world today. He can be exposed to various fire hazards through controlled burns to test burn protection properties of garment constructions, fabric weights, material types and garment design styles. Results predict the amount, degree and location of burn injuries that would be sustained by the wearer in a flash fire.

DuPont scientists use this information to help apparel manufacturers develop optimum designs in lightweight, flame-resistant suits that equip drivers, pit crews, rescue teams and track officials with garments that are comfortable and provide the best thermal protection possible.



JOEY COULTER, STOCK CAR DRIVER

FABRIC COLOR RANGE

DuPont™
Nomex

COLORS	WHITE	BLACK	NAVY BLUE	ROYAL BLUE	PACIFIC BLUE	PEWTER	YELLOW	GOLDEN YELLOW	GOLD	GREEN	LIME GREEN	PURPLE	PINK	RED	ORANGE
TITANIUM NOMEX® Our lightest weight fabric. High luster finish. Excellent choice for custom design incorporating embroidery and trim.	•	•	•	•	•	•	•	•	•	•	N/A	•	N/A	•	•
SIGNATURE KNIT NOMEX® A lightweight comfortable fabric with excellent breathability. It offers superior fire protection, and a subtle stretch for added mobility.	•	•	•	•	N/A	N/A	•	N/A	N/A	•	N/A	N/A	N/A	•	•
SATIN/TWILL Semishiny woven fabric with a relaxed, soft and supple feel, available in a wide variety of colors.	•	•	•	•	N/A	•	•	•	N/A	•	•	•	•	•	•

- = Available N/A = Not Available
- Titanium Nomex® also available in Busch Blue.
- Satin/Twill also available in Maroon and Brown.

CUSTOM SUIT DESIGN OPTIONS

TRIM CHARGES SHOWN ARE IN ADDITION TO THE BASE SUIT PRICE.

Custom suit design options, choose your colors from our wide selection.

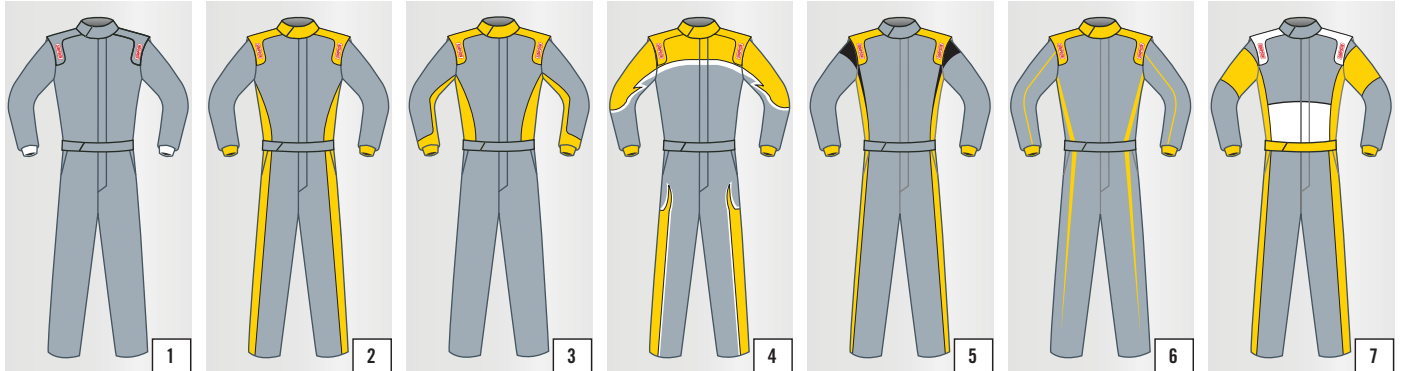

N/C

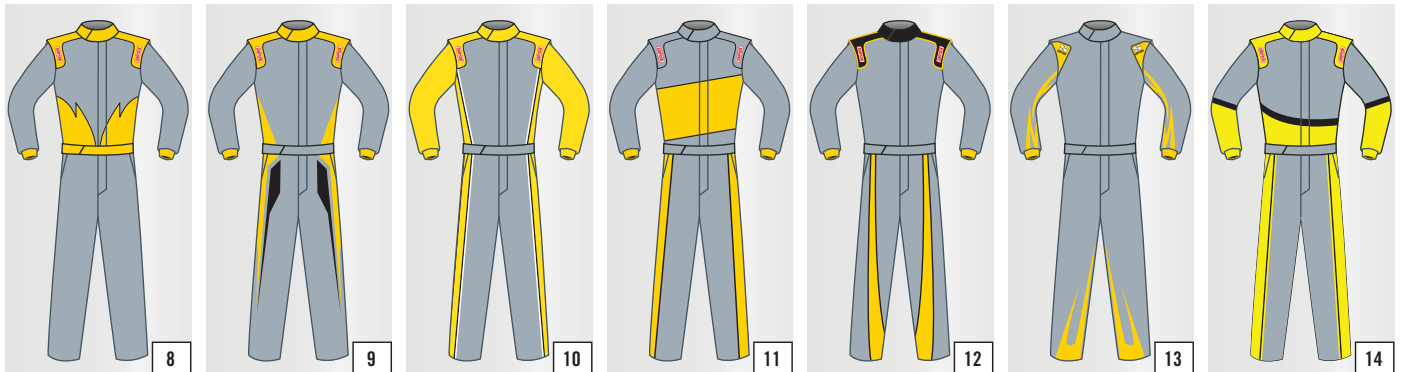

CUSTOM MADE-TO-ORDER RACING SUITS

Our Made-To-Order custom racing suits are made to order per your exact specifications at our factory in the USA. They are SFI approved and feature genuine DuPont™ Nomex® fabric. Our suits provide protection and comfort from over 14 measurements that are uniquely yours for a true custom fit. Our custom racing suits are offered in single layer, 2-layer and 3-layer suits as well as drag racing suits. Try our lumbar stretch panels for added comfort and ease of movement. Our large selection of color choices allows for compatibility with sponsor requirements.

EACH MTO SUIT INCLUDES

- Custom fit with 14 different measurements
- Vertical quilt
- Choice of collar (banded, soft knit, wraparound)
- Zippered breast pocket on select styles
- Epaulets with Simpson logos included
- Name embroidered on front belt
- Inset front pockets
- Colored rib cuffs (Red, White, Blue or Black)
- SFI tags included where mandated

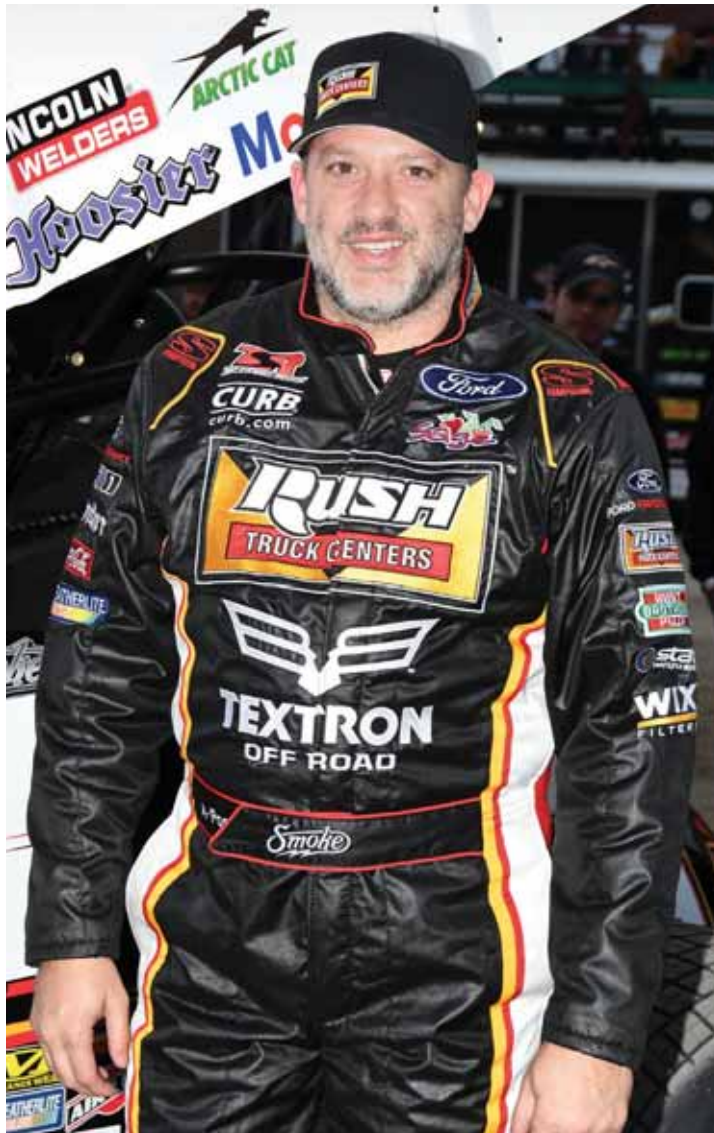

Available Features

The suits pictured in our custom suit section are here to show you the multitude of style and material options that are available. When you see the Custom logo next to a racing suit, the product is available in custom colors and features. You are not limited by any of these designs in any particular suit style. Design your own suit with the available features below.

ADD ON FEATURES

- 360° FULL ARM GUSSETS
- LOWER BACK EXPANDABLE GUSSET
- BOX QUILT MATCHED TO SUIT UNLESS CONTRASTING THREADS ARE REQUESTED
- REAR PATCH POCKET
- STRAIGHT LEG CUFF
- BUILT-IN ARM RESTRAINTS
- TWO PIECE SEPARATES, JACKET AND PANT
- HOOF OPTION, STRAIGHT LEG CUFF REQUIRED
- CUSTOM DESIGN AND EMBROIDERY AVAILABLE

RACER DELUXE PACKAGE: BEST VALUE!

- INCLUDES 360 DEGREE ARM GUSSETS, LOWER BACK GUSSET.
- STRAIGHT LEG CUFF AND BOX OR VERTICAL QUILT



TONY STEWART "SMOKE",
TONY STEWART RACING,
IMAGE COURTESY OF FRANK'S PHOTOS

CUSTOM DNA

SIMPSON SUIT FEATURING
NOMEX

SFI 3.2A/5

MADE IN U.S.A.

The DNA suit combines industry-changing innovations and advanced design in a suit that offers almost no restrictions to movement, unbeatable breathability and incredibly lightweight fabric. This game-changing suit is constructed to meet the needs of our athletes on the track and loaded with features available only at Simpson.

CODE:
MT0.26

COLORS
See page 54

THE PACKAGE INCLUDES

SFI.5 approved Titanium Nomex® racing suit, Made in the USA

Integrated cuffs replace traditional sleeve cuffs, minimizing material at your wrist and eliminating bunching in the glove gauntlet area

X-Tech stretch elbows allow for effortless movement of the arms, helping with fatigue and stopping the sleeve from migrating up the arm

X-Tech stretch body panels reduce tension across the back, torso, waist, hips and thighs

Stretch panels offer improved ventilation in key areas of the body

Stylish outside pockets lay flat to eliminate bunching and require less material

Embroidered trim adds style without adding unwanted weight



DONNY SCHATZ,
TONY STEWART RACING,
IMAGE COURTESY OF FRANK'S PHOTOS

DRIVER'S PERFORMANCE PACKAGE

AMP UP YOUR CUSTOM SUIT!

Simpson's Driver Performance Package may be added to any custom suit.

CODE:
PERFPKG

THE PACKAGE INCLUDES

- Fast back epaulets
- Flying V quilting adds bold styling
- Elbow stretch panels reduce arm fatigue
- Front only half belt is non-binding
- Neck, sides and lower back X-Tech stretch ventilation reduces binding and improves breathability
- Innovative above the knee and crotch gussets reduce thigh and knee stress
- Tapered leg minimizes excess material and reduces weight

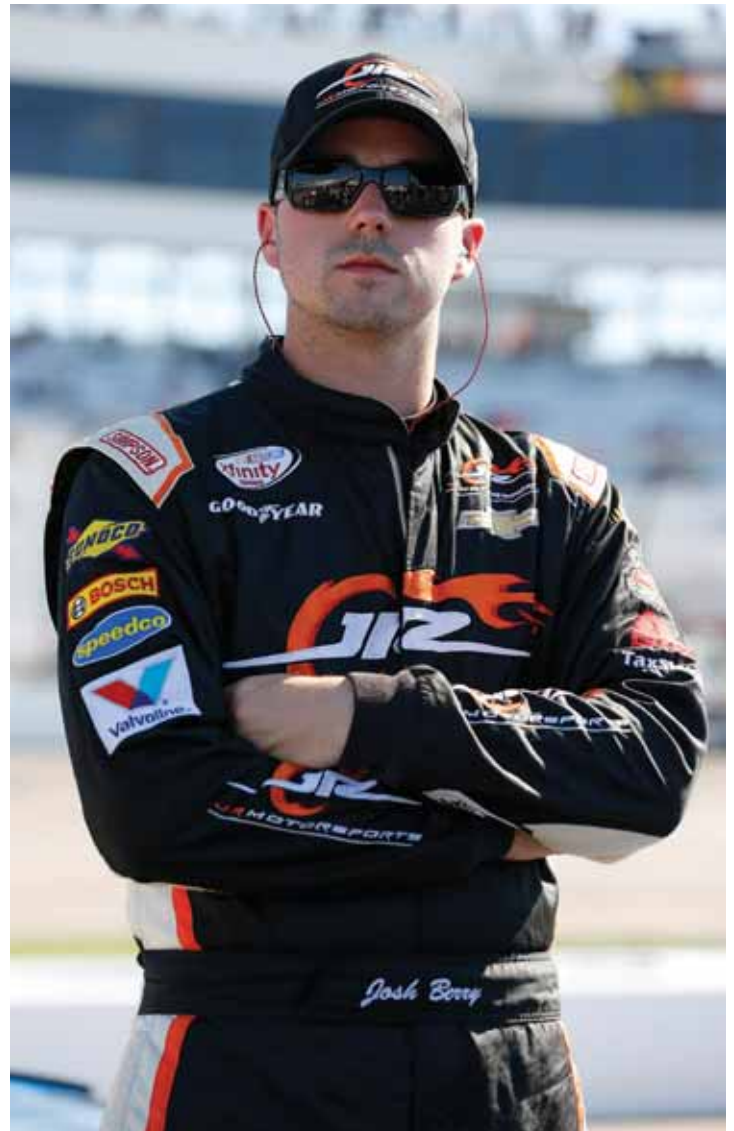

JOSH BERRY,
JR MOTORSPORTS,
IMAGE COURTESY OF JR MOTORSPORTS

PRO LITE CUSTOM DRAG SUITS



Less is more with our newest SFI 15 drag racing suit, the Pro Lite. Experience exceptional breathability and lightweight comfort without sacrificing protection. Custom in every way, our suits move with the racer allowing maximum comfort behind the wheel. Our exclusive materials provide strategic stretch without bulkiness, for a sleek presentation. Simpson is the official safety partner to John Force Racing, providing top quality gear for NHRA Funny Car champions John Force and Robert Hight and all of the JFR athletes. Shop our line of SFI 15 and SFI 20 suits here.

FEATURES

2-Piece Drag Suits

Suit shown in Signature Knit Nomex fabric with custom trim designs.

Call for quote.

All SFI.15 and SFI.20 suits feature our standard vertical quilting; box quilting available upon request
Arm restraints, full arm gusset



sfi 3.2A/20

CODE MD.50W
FABRIC NEW PRO LITE NOMEX® / 1-PIECE
COLORS: Black, Blue, Red, White

sfi 3.2A/20

CODE MD.50T
FABRIC SIGNATURE KNIT NOMEX® / 1-PIECE
COLORS: Royal Blue, White, Black, Navy, Red, Orange, Green, Yellow

MD.50KS SATIN/TWILL 1-PIECE
COLORS: Royal Blue, White, Black, Navy, Red, Silver, Orange, Green, Purple, Yellow, Golden Yellow, Lime Green, Pink

sfi 3.2A/15

CODE MD.40T
FABRIC SIGNATURE KNIT NOMEX® / 1-PIECE
COLORS: Royal Blue, White, Black, Navy, Red, Orange, Green, Yellow

MD.40KS SATIN/TWILL 1-PIECE
COLORS: Royal Blue, White, Black, Navy, Red, Silver, Orange, Green, Purple, Yellow, Golden Yellow, Lime Green, Pink



ROBERT HIGHT,
NHRA FUNNY CAR DRIVER,
JOHN FORCE RACING

CUSTOM SFI.1 AND SFI.5 RACING SUITS



sfi 3.2A/1

CODE
MTO.6
FABRIC
SATIN/TWILL CUSTOM FIT
COLORS: Royal Blue, White, Black, Navy, Red, Silver, Orange, Green, Purple, Yellow, Golden Yellow, Lime Green, Pink

sfi 3.2A/5

CODE
MTO.26
FABRIC
TITANIUM NOMEX®/CUSTOM DNA
COLORS: Royal Blue, White, Black, Red, Yellow, Golden Yellow, Silver, Gold, Navy, Pacific Blue

CODE
MTO.24
FABRIC
TITANIUM NOMEX® / CUSTOM FIT
COLORS: Royal Blue, White, Black, Red, Yellow, Golden Yellow, Silver, Gold, Navy, Pacific Blue

CODE
MTO.25
FABRIC
SIGNATURE KNIT NOMEX® / CUSTOM FIT
COLORS: Royal Blue, White, Black, Navy, Red, Orange, Green, Yellow

CODE
MTO.21
FABRIC
SATIN/TWILL CUSTOM FIT WITH KNIT RIB LINING
COLORS: Royal Blue, White, Black, Navy, Red, Silver, Orange, Green, Purple, Yellow, Golden Yellow, Lime Green, Pink

sfi 3.2A/5

CODE
MTO.33
FABRIC
SIGNATURE KNIT NOMEX® / CUSTOM FIT
COLORS: Royal Blue, White, Black, Navy, Red, Orange, Green, Yellow

CODE
MTO.33
FABRIC
SATIN/TWILL CUSTOM FIT
COLORS: Royal Blue, White, Black, Navy, Red, Silver, Orange, Green, Purple, Yellow, Golden Yellow, Lime Green, Pink



JUSTIN ALGAIER,
JR MOTORSPORTS

LIGHTWEIGHT AND NON-RATED FULLY SUBLIMATED CUSTOM SUIT



IDEAL FOR KARTING OR PHOTOGRAPHY

Simpson's Non-FR Suits offer the professional look you want both on and off the track. By sublimating directly onto the fabric, we can offer a lightweight suit with endless color and design options. Sublimation reduces your cost by eliminating intricate embroidery. It is a vivid color process that will look as good at the end of the season as it did when you removed it from the box. Unlimited sponsor logos and lettering. Suit features: custom fit and tailored measurements, vertical quilt, choice of collar (banded, soft knit, wraparound), zippered breast patch pocket (not available for styles C/D/F/I/K/L), epaulets, name embroidery (standard type face on belt: Script), inset front pockets, and colored rib cuffs (Red, White, Blue, Black). Customer to supply vector artwork.



Sublimated Kart Suit, 1 Piece

CODE MK.TS
 SIZE CUSTOM FIT
 FABRIC: 600 DENIER POLY

Sublimated Kart Jacket

CODE MT.KSJ
 SIZE CUSTOM FIT
 FABRIC: 600 DENIER POLY

Suit Options Available. Additional charges apply:

- FEATURES
- 360° FULL ARM SHOULDER GUSSET
 - LOWER BACK EXPANDABLE GUSSET
 - BOX QUILT (MATCHES SUIT COLOR: CONTRAST THREAD AVAILABLE)
 - STRAIGHT LEG CUFF
 - 2-PIECE DRIVING SUIT (SEPARATE JACKET & PANT)
 - RACER'S DELUXE PACKAGE:
360° arm gussets, lower back gussets, straight leg cuff and full box quilt.
 - EMBROIDERY (CUSTOM LOGOS & GRAPHICS)



NEW SIX 0 RACING SUIT



Celebrating our 60 years in the racing firesuit business, we proudly introduce the Six 0 premium racing suit, our newest lightweight two-layer SFI-5 suit that offers flexibility and functionality all in one! An attractive contemporary trim design sets this suit apart from the ordinary.

The Satin outer layer has a slight sheen combined with a soft knit inner layer. The Six 0 offers excellent breathability without sacrificing fire protection. Well-placed stretch panels move with the racer both in and out of the car, offering superior memory for a great fit.

FEATURES

- SFI.5 Rated
- Satin knit fabric with stylish non-contrasting V-quilting
- Adjustable ultra-soft knit collar and half-belt for a streamlined fit
- X-Tech body stretch panels in the side, back, thighs and knees that offer improved ventilation
- Straight leg cuffs
- 360° full arm gusset allowing full floating sleeves and unrestricted movement
- Four colorway options

CODE:
STD.13

SIZE:
S-XXL

COLORS

Black/Grey, Black/Blue, Black/Red, Blue/Red

15% UPCHARGE FOR XXL



FREDRIC AASBO,
FORMULA DRIFT DRIVER,
PAPADAKIS RACING



DNA SFI 5 RACING SUIT



CODE: **DNA** SIZE: **S, M, L, XL**

Become One Step Ahead of Your Competition With Today's Most Advanced Racing Suit customized in your team and sponsor colors and logos. See page 56 for custom DNA.

Our Popular DNA suit combines industry-changing innovations and advanced design in a suit that offers almost no restrictions to movement, unbeatable breathability and incredibly lightweight fabric. This game-changing suit is constructed to meet the needs of our athletes on the track and loaded with features available only at Simpson. The DNA suit combines industry-changing innovations and advanced design in a suit that offers almost no restrictions to movement, unbeatable breathability and incredibly lightweight fabric.

FEATURES

- SFI.5 approved Titanium Nomex racing suit, Made in the USA
- Integrated cuffs replace traditional sleeve cuffs, minimizing material at your wrist and eliminating bunching in the glove gauntlet area
- X-Tech stretch elbows allow for effortless movement of the arms, helping with fatigue and stopping the sleeve from migrating up the arm
- X-Tech stretch body panels reduce tension across the back, torso, waist, hips and thighs
- Stretch panels offer improved ventilation in key area of the body
- Stylish outside pockets lay flat to eliminate bunching and require less material
- Embroidered trim adds style without adding unwanted weight

COLORS

Red/White, Blue/White, Black/White

SUIT FABRIC

Titanium Nomex®



INTEGRATED CUFFS

replace traditional sleeve cuffs, minimizing material at your wrist and eliminating bunching in the glove gauntlet area



X-TECH STRETCH ELBOWS

allow for effortless movement of the arms, helping with fatigue and stopping the sleeve from migrating up the arm

RACING SUIT SIZE CHART

SIZE	CHEST	WAIST	HIP	INSEAM	NECK	HEIGHT	WEIGHT
SMALL	30-34	26-30	33-37	31	14.5	5'5" TO 5'7"	115 TO 130
MEDIUM	34-38	30-34	37-41	32	15.5	5'7" TO 5'10"	140 TO 165
LARGE	38-42	34-38	41-45	33	16.5	5'10" TO 6'2"	175-200
XL	42-46	38-42	45-49	34	17.5	5'11" & OVER	210-225
XXL	46-50	42-46	49-53	35	18.5	5'11" & OVER	235 TO 250

YOUTH RACING SUIT SIZE CHART

SIZE	CHEST	WAIST	HIP	INSEAM	NECK	HEIGHT	WEIGHT
XS	28-31	21-24	26-29	22	11	4'0" TO 4'4"	50 TO 60
SMALL	31-33	24-26	29-31	23	12	4'1" TO 4'5"	60 TO 75
MEDIUM	33-36	26-28	31-33	24	13	4'5" TO 4'10"	75 TO 90
LARGE	36-38	29-31	34-36	26	13	5'0" TO 5'4"	90 TO 105
XXL	39-41	32-34	38-40	28	14	5'4" TO 5'6"	105 TO 120



NEW SPORTSMAN ELITE III RACING SUIT



Updated styling for the Sportsman Elite III features top and bottom full contrast. The Sportsman Elite suits are a great value with stylish and functional features including straight leg cuffs, 360° arm gussets and 3-point epaulets.

FEATURES

SFI.5 Rated
Patch style pockets
Contrasting color style
Available in one-piece design or as separate jacket and pants

COLORS

Black/Grey, Red/Grey, Blue/Grey

Sportsman Elite III

CODE	SIZE: S-XXL
STD.16	1-PIECE 15% UPCHARGE FOR XXL
STD.16	JACKET 15% UPCHARGE FOR XXL
STD.16	JACKET WITH BUILT-IN ARM RESTRAINTS 15% UPCHARGE FOR XXL
STD.5	PANT 15% UPCHARGE FOR XXL

SPORTSMAN ELITE II RACING SUIT



The Sportsman Elite II suits come with many of the same features as our MTO suits at half the price. Contrasting Platinum chest band and extensive white piping, banded collar, 360° arm gusset, 3-point epaulets, patch style pockets, straight leg cuffs, colored rib cuffs and vertical quilting.



Sportsman Elite II

CODE	SIZE: S-XXL
STD.15	1-PIECE 15% UPCHARGE FOR XXL
STD.15	JACKET 15% UPCHARGE FOR XXL
STD.15	JACKET WITH BUILT-IN ARM RESTRAINT 15% UPCHARGE FOR XXL
STD.15	PANT 15% UPCHARGE FOR XXL

COLORS

Black, Red, Royal Blue

FABRIC

Satin/Twill with fleece lining

RACING SUITS

QUALIFIER RACING SUIT

The Qualifier SFI 3.2/5 Race suit is two-layer construction, lightweight and extremely breathable, and features our softest rib knit lining. The Qualifier has pre-curved floating sleeves and straight-leg cuffs with a two-tone modern design.

FEATURES

Satin Twill with soft rib knit lining
 Straight cut leg
 360° Full arm gusset
 Ultra-soft knit cuffs
 SFI 3.2A/5 certified

COLORS

Black/Grey, Blue/Grey, Red/Grey

FABRIC

Satin/Twill



Q1 QUALIFIER RACING SUIT

CODE	SIZE: S-XXL
STD Q1	1-PIECE
	15% UPCHARGE FOR XXL
STD Q1	PANT
	15% UPCHARGE FOR XXL
STD Q1	JACKET
	15% UPCHARGE FOR XXL



HELIX RACING SUIT



The Helix driving suit belongs to our DNA strand of high-performance racing products. Simpson's DNA products are designed with athletic performance-enhancing features engineered to reduce weight and driver restrictions. Available in Adult and Youth Sizing.

CODE: HX SIZE: ADULT S - XXL

CODE: HX-Y SIZE: YOUTH XS - XL

See page 71 for Youth Helix.

FEATURES

SFI.5 Rated
 270° arm and back gussets
 Knee and inner thigh stretch panels
 Lower back stress relief panel
 Upper back ventilation port
 No bulk, weight-saving patch pockets and embroidered trim and logo

COLORS

Black, Red





SUPER SPORT RACING SUIT



Satin/Twill suit with vertical quilting and fleece inner lining of 100% Nomex®. Featuring inset pant pockets, straight leg cuffs. Available in both 1-piece and 2-piece design.

COLORS

Black, Red, Royal Blue

FABRIC

Satin/Twill with fleece lining



Super Sport

CODE	SIZE: S-XXL
STD.SS	1-PIECE
	15% UPCHARGE FOR XXL
STD.SS	PANT
	15% UPCHARGE FOR XXL
STD.SS	JACKET
	15% UPCHARGE FOR XXL
STD.SS	JACKET WITH RESTRAINTS
	15% UPCHARGE FOR XXL

SFI-5 CLASSIC RACING SUIT



Our SFI-5 suit features woven Satin/Twill fabric with vertical quilting and zippered patch style breast pocket, straight leg cuff available.

COLORS

Black, Red, Royal Blue

FABRIC

Satin/Twill with fleece lining



SFI-5 Classic

CODE	SIZE: S-XXL
04 STD.19	1-PIECE
	15% UPCHARGE FOR XXL
04 STD.19	JACKET
	15% UPCHARGE FOR XXL
04 STD.19	JACKET WITH BUILT-IN ARM RESTRAINTS
	15% UPCHARGE FOR XXL
04 STD.19	PANT
	15% UPCHARGE FOR XXL

RACING SUITS

VIXEN II FEMALE RACING SUIT

We love the Vixen II redesign that offers SFI 3.2/5 protection in a comfortable and stylish suit designed to accentuate curves and move with the racer. We began with the finest fabric interior and Shiny Twill outer layer. The Vixen II provides maximum protection from burn situations while at the same time delivering style and attention to detail. The design curves smoothly along the body shape with strategic darts, providing less bulk and a sleek silhouette. The front pockets lay flat and special attention has been given to the bust, waist and hip area, offering a proportion that is both desirable and wearable to our female racers.

COLORS

Ebony Black with White Trim

Ebony Black with Pink Trim

Call for additional color options

FABRIC

Satin/Twill Satin Twill outer with soft knit ribbed interior



CODE:
STD.18

SIZE:
XS - L, (XS 0-2, S 4-6, M 8-10, L 12-14)

COURTNEY FORCE, NHRA FUNNY CAR DRIVER, JOHN FORCE RACING



HPD-1 RACING SUIT DUAL CERTIFIED!



FIA and SFI 3.2A/5 certified. With Sports Car, Rally and Road Racing in mind, Simpson's lightweight 3-layer, HPD-1 racing suit is loaded with functionality and performance. Impressive features include raglan style epaulettes, heat relief panels in back of neck, 360° arm gussets, stretch panels at the elbow and thigh area, front half belt, and white/red or white/grey color combinations. Coordinating arm and leg cuffs and an attractive quilt stitch pattern finish out this suit. The HPD-1 is simplistic in design and loaded with functionality.

COLORS

White/Red Trim, White/Grey Trim

FABRIC

Satin/Twill

CODE:
RS

SIZE:
US: S - XL EURO: 48, 50, 52, 54



LEGEND II RACING SUIT

The Legend II is an affordable SFI.1 rated racing suit tailored to the needs of the racer. We have added distinctive styling and 3-point epaulets. This entry-level FR Cotton suit includes a wraparound collar and 3-point epaulets with Simpson branding. We have also included vertical quilting, 360° full arm gussets, straight leg cuffs and front pockets. Choose from a complete range of Adult and Youth sizes.

COLORS

Solid Black, Black/Grey Combo (*not shown*)

FABRIC

SFI-1 FR Cotton



YOUTH SIZES AVAILABLE 

CODE:
STD.LII

SIZE:
S - XL

YOUTH LEGEND II AVAILABLE, SEE PAGE 71.



SFI-1 CLASSIC RACING SUIT

The SFI-1 suit features our Classic 3-stripe design in woven Satin/Twill with a zippered breast pocket. (*2 piece shown*)

FABRIC
Satin/Twill



SFI-1 Classic

CODE
03 STD.6

SIZE: S-XXL
1-PIECE
15% UPCHARGE FOR XXL

03 STD.6

JACKET
15% UPCHARGE FOR XXL

03 STD.6

PANT
15% UPCHARGE FOR XXL

RACING SUITS

SFI-15/SFI-20 DRAG RACING SUITS



Standard drag racing suits include contrasting piping, full arm gussets, SFI tag, built-in arm restraints and vertical stitching.

The suit is shown with box quilt and comes standard with vertical quilt.

COLORS

Black, Red, Royal Blue (not shown)



SFI-15 Drag Racing Suit

CODE
STD.49T
STD.49T

FABRIC
SIGNATURE KNIT NOMEX® / 1-PIECE
SIGNATURE KNIT NOMEX® / 2-PIECE PANT & JACKET

SFI-20 Drag Racing Suit

CODE
STD.48T
STD.48T

FABRIC
SIGNATURE KNIT NOMEX® / 1-PIECE
SIGNATURE KNIT NOMEX® / 2-PIECE PANT & JACKET

HOLESHOT 20 DRAG GLOVE



The Holeshot 20 Drag Glove is SFI 3.3/20 approved and made in the USA and is 20% lighter than the competition. Newly developed Nomex® technology with conforming stretch for improved dexterity.

COLOR
Black



CODE:
37015

SIZE:
S - XL

HOLESHOT 20 DRAG BOOTS



The Holeshot 20 Drag Boot is SFI 3.3/20 approved and made in the USA and is 50% lighter than standard drag boots. Newly developed Nomex® material stretches over the shoe for improved fit and comfort. Includes zipper and adjustment strap.

COLOR
Black

CODE:
37021

SIZE:
S - XL

FOOT SIZE	5½-7"	7-8½"	8½-10"	10-11½"	11½-13"
SHOE SIZE	S	M	M/L	L	XL



UTV SPORT VINTAGE STYLE SUIT



UTV Suit features our popular 3 stripe retro styling
 One-piece suit meets and exceeds SFI 3.2A/1 and SFI 5 3.2/5 requirements
 Black Ankle and Wrist Cuffs
 Standard Shoulder Epaulets
 Red, Orange and Yellow racing stripes on driving suit arms

CODE:
U3

SIZE:
SFI 3.2/1 RATED

CODE:
U4

SIZE:
SFI 3.2/5 RATED

SIZES

Small – XXL Large, 15% upcharge for XXL

COLOR

Black Only

CROSSOVER RACING SUIT

The Crossover suit is SFI.5 rated with multilayers of fire protection. Simpson branded at epaulets. Banded collar and straight leg cuffs. Back gusset is designed for comfort. Includes 360° arm gussets.

COLORS

Black/White/Grey

FABRIC

Satin/Twill



CODE:
STD.CO

SIZE:
S-XXXL (XXL, XXXL PLUS %15)

RACING SUITS

APEX KART RACING SUIT

The Apex Suit is ergonomically designed to offer resistance abrasion for karters and stylish visibility on the track. The fabric is lightweight, fade resistant and durable. Non-restrictive stretch panels enhance the racer's comfort.

FEATURES

Lightweight Cordura® construction is highly resistant to abrasion
Soft mesh inner lining at the sleeve and thigh areas for comfort and breathability and maximum air flow
Fully floating arms minimize bulk around the shoulders
Knit wrist and ankle cuffs offer a sleek fit
Fully adjustable collar and front belt
Attractive modern style epaulets

COLORS

Black w/Grey Trim, Red w/Grey Trim (shown)



CODE:
AP

SIZE:
S, M, L, XL

APEX KART GLOVE

The Apex glove is styled for karting and enthusiasts and is not an SFI rated glove.

COLORS

Black, Blue, Red

CODE:
AX

SIZE:
XS-XXL



APEX KART RACING JACKET



FEATURES

Jacket features extended back heatshield panel across shoulder area for added protection

COLORS

Black, Red (not shown)

FABRIC

Poly Duck

NO TPP RATING. NOT FIRE RETARDANT.



CODE:
01 STD. K

SIZE:
S - XXL 15% UPCHARGE FOR XXL

JR/YOUTH RACING SUITS

HELIX YOUTH RACING SUITS

The Helix SFI 5 Youth driving suit is designed with athletic performance-enhancing features engineered to reduce weight and young driver restrictions. The Helix is available in Adult and Youth Sizing.

FEATURES

- SFI.5 Rated
- 270° arm and back gussets
- Knee and Inner Thigh Stretch Panels
- Lower back stress relief panel
- Upper back ventilation port
- No-bulk, weight-saving patch pockets and embroidered trim and logo.



CODE:
HX-Y

SIZE:
XS - XL

COLOR
Black/Grey

FABRIC
Satin/Twill

SFI.5 BASIC AND PREMIUM YOUTH SUITS (NOT SHOWN)



FEATURES:

- Solid color suit
- Double racing stripes on arms and legs:
Simpson logos on arms and cuffs
- Stylish inset pockets and banded collar
- Traditional cuff leg, basic model
- Straight leg cuff, premium model

COLOR SELECTION

Black, Blue and Red

CODE:
STD.Y4
STD.P4

SIZE:
BASIC MODEL, XS-XL
PREMIUM MODEL, XS-XL



YOUTH LEGEND II SUIT



The Youth Legend II Suit is an affordable SFI.1 rated cotton firesuit tailored to the needs of the young racer. We have added distinctive styling and attractive color combinations. This quality sewn FR Cotton suit includes a wraparound collar and 3-point epaulets with Simpson branding. The Legend II has vertical quilting, 360° full arm gussets, straight leg cuffs and front pockets.

CODE:
STDY.LYII

SIZE:
YXSM, YSM, YMED, YLG, YXL

SEE YOUTH SIZE CHART ON PAGE 62.

COLORS

Black with White trim, Black with Red trim

FABRIC

SFI-1 FR Cotton

JR KART SUITS (NOT SHOWN)

Karting suits are not SFI rated. Constructed of 600 Denier Poly, single layer.

KART SUIT COLORS

Black, Blue and Red

CODE:
STD.Y1
STD.P1

SIZE:
BASIC MODEL, XS-XL
PREMIUM MODEL, XS-XL

MEMORY FIT UNDERWEAR



Our newest fire retardant memory fit underwear is race tested by NASCAR's pro racers. The unique memory fit fabric stretches both horizontally and vertically with great bounce back and becomes softer with each washing. You may want to order two sets, because this will quickly become your go-to underwear for added race protection.

FEATURES

- SFI 3.3 Certified
- Made in the USA
- Nomex® blend provides added fire protection
- Anti-microbial treated
- No bulk, unique memory stretch provides built in comfort, while retaining shape
- Contrast stretch stitching for definition



Memory Fit

CODE	MEMORY FIT LONG SLEEVE TOP
20123	MEMORY FIT BOTTOM
20124	MEMORY FIT SHORT SLEEVE TOP
20125	



LADIES FR BRA



Top is constructed of 4-way stretch Nomex® protective fabric and functions as an added layer of protection and improved comfort under a racing suit. This safe alternative to unisex undergarments is free of dangerous underwire, snaps and hooks. The Simpson sports top is designed with soft comfort in mind. The wide chest band and shoulders stay in place and are non-binding.

COLOR
Black



CODE: **20606** SIZE: **XS - XL**

CHEST BAND SIZE	28"/30"	30"/32"	32"/34"	34"/36"	36"/40"
SIMPSON BRA SIZE	XS	S	M	L	XL

* WEARING NYLON OR POLYESTER WHILE RACING IS NOT RECOMMENDED. THESE MATERIALS CAN MELT WHEN EXPOSED TO EXTREME HEAT AND CAN CAUSE SERIOUS INJURIES.

CarbonX® ULTIMATE™ UNDERWEAR



CarbonX® delivers base layer products with extraordinary thermal protective properties, including CarbonX® Ultimate™ Underwear. (XXL available with 15% upcharge).

COLOR
Black



LONG SLEEVE AVAILABLE

CarbonX® Ultimate™

CODE	SIZE: S-XXL
20600	LONG SLEEVE TOP
20601	BOTTOM
20602	SHORT SLEEVE CREW NECK TOP <i>NOT SFI CERTIFIED</i>

70Z. (NOT SHOWN)



COLORS
Natural

70Z.

CODE	SIZE: S-XXL
20000	LONG SLEEVE TOP (XXL AVAILABLE WITH 15% UPCHARGE)
20001	FULL LENGTH BOTTOM (XXL AVAILABLE WITH 15% UPCHARGE)

SAFETY TIP

Nomex® or CarbonX® underwear underneath the racing suit will dramatically improve Thermal Protection Performance (TPP) in the case of an accident involving fire.

NOMEX® UNDERWEAR

Our softest Nomex® knit for added comfort. Available in short or long sleeve and full length bottom. Meets SFI 3.3 and includes tag. Youth sizes available.



Nomex® Underwear

CODE	SIZE: S-XXL
20100	SHORT SLEEVE TOP (XXL AVAILABLE WITH 15% UPCHARGE) <i>NOT SFI CERTIFIED</i>
20110	LONG SLEEVE TOP (XXL AVAILABLE WITH 15% UPCHARGE)
20101	BOTTOM (XXL AVAILABLE WITH 15% UPCHARGE)

RACING SUITS

KEVLAR® SLEEVE & GLOVES

Designed for mechanics and crew members to help prevent cuts or burns while working a hurried pit stop. Can be worn under SFI-20 driving glove for added protection.



CODE:
39024

SIZE:
ONE SLEEVE / ONE SIZE

CODE:
39020

SIZE:
GLOVES / S - XL

FUELER APRON

Includes adjustable Kevlar straps.

COLOR
Silver



CODE:
39042

SIZE:
ONE SIZE

MECHANICS APRON

Polyester cotton blend. one upper pocket.
Includes adjustable nylon straps.

COLOR
Black



CODE:
39035

SIZE:
ONE SIZE

PROTECTIVE ACCESSORIES

FIA NOMEX® BALACLAVA

Simpson's FIA Nomex Balaclava features a frontal design utilizing a dual layer of Nomex® for increased protection.

COLOR

Natural



FIA Nomex® Balaclava

CODE	TYPE
23004W	SINGLE EYEPORT
23005W	DUAL EYEPORT

CarbonX® BALACLAVA

Delivers Ultimate™ protection to the critical face and neck areas. Moisture wicking. Fits any full face helmet contour; wear in or out. Includes SFI tag.

COLOR

Black



Carbon x® Balaclava

CODE	TYPE
23000C	SINGLE EYEPORT
23003C	DUAL EYEPORT

MEMORY FIT BALACLAVA

The lightweight unique memory fit fabric stretches both horizontally and vertically for an overall comfortable fit.

COLORS

Black, White (not shown)



Memory Fit Balaclava

CODE	TYPE
23050	SINGLE EYEPORT
23051	DUAL EYEPORT

SFI NOMEX® BALACLAVA

Knitted from extra-plush Nomex®. Designed to be worn under most helmets. Single or dual eye port. Includes SFI tag. Youth sizes available.

COLORS

Natural, Black (not shown)



SFI Nomex® Balaclava

CODE	TYPE
23000	SINGLE EYEPORT
23003	DUAL EYEPORT



NOMEX® HELMET SKIRT

Dual layer material. Keeps dust and debris out of helmet. Attaches easily with speed fit system. Includes SFI tag.

COLORS

Black, Natural (not shown)



Nomex® Helmet Skirt

CODE	TYPE
23012	STANDARD
23013	CONTOURED
23014	LARGER HELMET OPENING

CarbonX® HELMET SKIRT (NOT SHOWN)

Dual layer CarbonX® fleece material to comfortably protect neck and head.

COLOR

Black



Nomex® Helmet Skirt

CODE	TYPE
23012C	STANDARD
23013C	CONTOURED
23014C	LARGER HELMET OPENING

RACING SUITS

SONOMA PERFORMANCE CREW SHIRT

The Sonoma features a 3-button style and Simpson bar logo on the sleeve. Our most breathable fabric and tasteful contrast piping finish out this winning shirt.

COLORS

Red/Black, Grey/Black, Blue/Black

CODE:
39018

SIZE:
S - XL

CODE:
39018

SIZE:
XXL AND XXXL



TALLADEGA BUTTON DOWN

The Talladega features embroidered Simpson "S" logo, contrasting piping, attractive contrasting fabric (65% Poly, 35% Cotton), breathable mesh side panels and a stylish fit.

CODE:
39012

SIZE:
S - XL

CODE:
39012

SIZE:
XXL - XXXL



COLORS

Red/Black, Grey/Black, Blue/Black, Orange/Black, Yellow/Black, Black/Black
Limited Stock on Select Colors



CUSTOM SUBLIMATED CREW SHIRTS

Simpson makes thousands of sublimated crew shirts every year at our state-of-the-art racing suit and crew apparel manufacturing facility in Harbor City, California. When it comes to crew apparel, we know our business. In keeping with the colorful and sponsor-rich world of racing, our sublimation process allows for endless design and color combinations. Our selection of fabrics and style are durable and comfortable. Our service is impeccable, our in-house design staff is the best.

FEATURES

- Sublimated shirts are an economical option on high-volume orders
- Mesh, dazzle and poly poplin fabric choices
- Hidden snap-front closure or 1/4 zip
- Hidden snap-down collar
- Front welt pockets where applicable
- Larger sizes available, call for price quote



Custom Sublimated Crew Shirts

CODE
SUBLIMATED CREW SHIRTS

SIZE:
S - XXL
WOMEN'S SIZES ARE AVAILABLE

BASE PRICE
BASED ON QUANTITY



MOLECULE PERFORMANCE PRODUCTS



Molecule Car Cleaner removes road grime with ease, specifically addressing racing grime. Our detailer is easy to apply and quickly buffs to a glassy shine. Our fabric care products bond to Nomex® fabric to help repel flammable stains. Molecule Wash and Refresh keeps gear cleaner and safer by resisting contaminants that can degrade fabric performance. Protector sheds water, oils, fuels and dirt. Maintains fabric breathability. Fabric sunscreen reduces color fading caused by UV rays. Safe, water-based, patent pending formula.

NEW HELMET CARE KIT includes: Light Duty Cleaner & Polish in one spray, Refresher to keep the inside of helmet clean, Anti-fog to keep the inside of visor clear, Rain Repel on outside of visor, includes microfiber towel



CAR DETAILER PRODUCTS



PERFORMANCE FABRIC CARE

Helmet and Shield Care

CODE	TYPE	SIZE
MLHCK4	NEW HELMET CARE KIT	KIT
MLHCP4	HELMET CLEANER/POLISH	4 OZ. SPRAY
MLHFR4	HELMET FABRIC REFRESH	4 OZ. SPRAY
MLHRR4	HELMET RAIN REPEL	4 OZ. SPRAY
MLHAF4	HELMET ANTI FOG	4 OZ. SPRAY

Car Care

CODE	TYPE	SIZE
MLDET16	DETAILER	16 OZ.
MLCLE16	CLEANER	16 OZ.

Protective Fabric Care

CODE	TYPE	SIZE
MLWK161	WASH KIT: INCLUDES 16 OZ. WASH AND 16 OZ. SPOT REMOVER	16 OZ.
MLWTK44	TRIAL WASH KIT: INCLUDES 4 OZ. WASH AND 4 OZ. SPOT REMOVER	4 OZ.
MLWA16	WASH	16 OZ.
MLWAIG	NEW GALLON SIZE WASH	1 GAL.
MLSP16	SPOT REMOVER	16 OZ. SPRAY
MLRE16	REFRESHER	16 OZ. SPRAY
MLPR16	PROTECTOR	16 OZ. SPRAY
MLCK1	COMPLETE CARE KIT: INCLUDES 4 OZ. SPOT REMOVER, 16 OZ. WASH, 16 OZ. REFRESHER, 16 OZ. PROTECTOR	16 OZ.

HOLD ON FOR THE RIDE

GLOVES

DNA GLOVE

The DNA Glove is a high-performance driving glove constructed using knit Nomex® that conforms to each individual driver's hands for a unique custom fit. SFI 3.3/5 certified, the DNA glove features external seams, tapered and precurved fingers, precurved palm, exclusive DNA design silicone palm and finger grips, strategically placed knuckle and wrist bone padding and performance-inspired style lines. Wear the DNA for unmatched comfort & performance.

COLORS

Black/White, Black/Blue, Black/Red



SIMPSON GLOVES
FEATURING
NOMEX
®



CODE:
DG

SIZE:
S-XL



THE VORTEX GLOVE

SFI 3.3/5 rated and FIA Approved professional racing glove with Nomex® construction. Strategically placed wristbone padding provides additional protection. External seams and precurved palms provide comfort. Tapered and precurved fingers and fourchettes give the driver excellent control. Silicone palm gripper design and striking embroidered knuckle logo.

COLORS

White/Black or White/Grey, both with Red Premium Trim design



SIMPSON GLOVES
FEATURING
NOMEX
®



CODE:
VR

SIZE:
XS - XXL

CODE:
VR-F

SIZE:
FIA APPROVED



PREDATOR GLOVE

Lightweight Nomex® construction for ultimate comfort and fit. Digital fire-resistant leather with individual performance stress points. All Nomex®, extra-long gauntlet with forearm cuff for custom fit.

COLORS

Black, White



SIMPSON GLOVES
FEATURING
NOMEX
®

CODE:
20800

SIZE:
S - XL



GLOVES



WHEELER GLOVE NEW LONGER GAUNTLET



Certified to SFI 3.3/5 standard, the aggressively styled Wheeler Racing Glove features minimal seam construction and optimized levels of grip via a newly designed leather palm and fingers.

FEATURES

SFI 3.3/5 Certified
Fire-resistant aramid fiber main construction
Mid length gauntlet with convenient pull tab

COLORS

Black/Red and Black/White

CODE:
WG

SIZE:
XS - XXL



COMPETITOR GLOVE

Nomex® Construction with a distinctive white trim. The silicone palm and touchpoints give superior grip and limited bunching. Available with inside and outside seams.

COLORS

Black, Pink, White, Red



Competitor Glove

CODE
21300

FITS
S - XL, ALL COLORS
XXL, BLACK ONLY

21300-0

REVERSED SEAM



THE HI-VIS GLOVE



The Hi-Vis glove has been developed for professional drivers who like the feel of an all-leather palm. SFI 3.3/5 Rated Racing Glove with Nomex® construction.

COLORS

Black w/Yellow Trim, Yellow w/Black Trim
While supplies last.



CODE:
HV

SIZE:
XS - XXL



GLOVE SIZE CHART



SIZE	INCHES
XXS	5" TO 6"
XS	6" TO 7"
SMALL	7" TO 8½"
MEDIUM	8" TO 9½"
LARGE	9" TO 10½"
XL	10" TO 11½"

IMPULSE GLOVE

The Impulse Professional racing glove provides protection and grip in all the right areas. SFI 5 Rated Racing Glove with Nomex® construction. Exceptionally soft palm constructed of goat leather. Inside Seams.

COLORS

Red, Blue, Black



SIMPSON GLOVES
FEATURING
NOMEX
®

CODE:
IM

SIZE:
XXS - XXL



SUPER SPORT GLOVE

The Super Sport is an entry-level racing glove that protects and performs. SFI 3.3/1 Rated Racing Glove with Nomex® construction and silicone graphics finish out design. Available with inside seams only.

COLORS

Black w/White Graphic Trim



SIMPSON GLOVES
FEATURING
NOMEX
®

CODE:
SS

SIZE:
XS - XL

YOUNG GUN YOUTH GLOVE

Double-layer Nomex® knit construction with an SFI 3.3/5 rating. The Young Gun is super stylish and super protective. Available in kids' sizing Small, Medium and Large.

COLOR

Black with White with Silver accents



SIMPSON GLOVES
FEATURING
NOMEX
®

CODE:
YGY

SIZE:
S - L



HOLESHOT 20 DRAG GLOVE

Made in the USA. Meets SFI 20. 20% lighter than the competition. Newly developed Nomex® technology with conforming stretch for improved dexterity.

COLOR

Black



SIMPSON GLOVES
FEATURING
NOMEX
®



CODE:
37015

SIZE:
S - XL

WRENCHER II MECHANIC GLOVE

One tough glove built for everyday wear for riding your bike or UTV or hanging out in the garage. The Wrencher II is not fire-retardant. The Wrencher II runs small. Order one size up for best fit.

COLOR

Black



CODE:
39034

SIZE:
S - XL

CUSTOM GLOVE PROGRAM

You can order our Team Style SFI.5 certified glove with your own team logos and colors. See our stylish and functional Team Glove here. Our Team Glove features Nomex™ construction with silicone palm and touchpoints and outside seam construction.

COLORS

We offer multiple color choices. Contact us for details.

HOW IT WORKS

1. CHOOSE YOUR COLOR

Choose from the Nomex® constructed Black/White Team Glove. Featuring superior grip with silicone palm and touchpoints. This SFI certified glove is a popular choice for race teams.



SIMPSON GLOVES
FEATURING
NOMEX



GLOVE IS SHOWN IN OPTIONAL CUSTOM COLOR, YELLOW.

2. CHOOSE YOUR LOGO POSITION

Place your logo/art in the 3" by 7" print area. Also choose Position 1 or 2 for the Simpson logo.

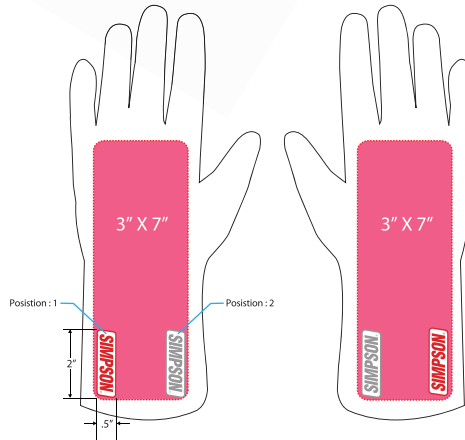

Large area for your artwork. Excellent position for camera exposure.

3. CHOOSE YOUR QUANTITY

Cost is based on your total quantity of pairs ordered with a unique print. Pricing is also based on the Simpson logo being on the glove.

PAIR(S):	1 – 6
PAIRS:	7 – 12
PAIRS:	13 +



LACE UP TO GEAR UP



SHOES

SHOES

DNA SHOE

The DNA Shoe is our newest slim, lightweight, form-fitting performance shoe with heat-releasing perforated panels designed to meet the needs of today's fastest drivers.

FEATURES

- SFI 3.3/5 certified
- DuPont™ Nomex® lining
- Plush tongue and ankle padding
- Exclusive pedal-sensitive rubber sole

COLORS

Black/White, Black/Red



CODE:
DA

SIZE:
4 - 14 (INCLUDES 1/2 SIZES)

REDLINE SHOE

The Redline shoe is SFI approved for racing and features a performance-enhancing, streamline design that is comfortable and pliable.

FEATURES

- Manufactured of top grain leather and fire-retardant Nomex®
- SFI, FIA approved
- Hidden laces
- Textured bumper panels
- Single large Velcro ankle strap

COLORS

Black/White, Black/Grey



CODE:
RL

SIZE:
6 - 14 (INCLUDES 1/2 SIZES)

CODE:
RL-F

FIA, BLACK/GREY

HIGHTOP SHOE *NEW TAKE ON OUR CLASSIC STYLE*



The Hightop is a high-top design with a satin suede upper and is SFI 3.3/5 approved. The inner fleece lining is FR. There is a triple layer anterior toe area for added wear protection with additional reinforcements in the heel and lace guard. Double speed-fit closure. The outer sole is a non-slip, super-sensitive polyurethane sole with posi-grip traction.

COLORS

Black, Blue, Red



CODE:
28000

SIZE:
4 - 14 BLACK (INCLUDES 1/2 SIZES)

CODE:
28000

SIZE:
8 - 12 BLUE, RED (INCLUDES 1/2 SIZES)

ADRENALINE SHOE



The Adrenaline is made from satin suede with a fleece fire-retardant lining and is SFI 3.3/5 approved. Triple layer anterior toe area for added wear protection with additional reinforcements in the heel and a speedfit lace closure. The low cut Achilles support gives maximum flexibility and comfort. The non-slip, super-sensitive polyurethane sole with posi-grip traction keeps you grounded.

COLOR

Black



CODE:
AD

SIZE:
4 - 14 (INCLUDES 1/2 SIZES)

CODE:
AD

SIZE:
YOUTH 1 - 3 (NO 1/2 SIZES)

MIDTOP SHOE



The Midtop shoe is SFI 3.3/5 certified. A single speed-fit closure locks away laces. Achilles relief cut for maximum flexibility. Fleece FR lining. Satin suede toe, heel and lace guard reinforcements. Triple layer anterior toe area for added wear protection. Non-slip, super-sensitive polyurethane sole with posi-grip traction.

COLORS

Two-tone: Black and Grey.



CODE:
MT

SIZE:
6 - 14 (INCLUDES 1/2 SIZES)

STEALTH SPRINT SHOE

The softer leather Stealth is SFI 3.3/5 approved with a modified lace guard for those who prefer a futuristic look. The high-top design features Simpson's easy to clean leather upper and super smooth leather toe, lace and heel guard reinforcements. The dual speedfit closure and exclusive EnviroGuard lace cover protects the seven hole lace-up. The internal construction features flat seams and fleece fire-retardant lining with an athletic insert. The outer sole is constructed of Type R polyurethane in a posi-grip pattern.

COLOR
Black



SIMPSON SHOES
FEATURING
NOMEX
®

CODE:
SP

SIZE:
6 - 14 (HALF SIZES AVAILABLE 8-12)



HOESHOT 20 DRAG BOOT

The Holeshoot Drag Boot is SFI 3.3/20 approved and made in the USA, and is 50% lighter than standard drag boots. Newly developed Nomex® material stretches over the shoe for improved fit and comfort. Includes zipper and upper adjusting strap.

COLOR
Black



SIMPSON SHOES
FEATURING
NOMEX
®



CODE:
37021

SIZE:
S - XL

FOOT SIZE	5½-7"	7-8½"	8½-10"	10-11½"	11½-13"
SHOE SIZE	S	M	M/L	L	XL



SHOE SIZE CONVERSION CHART

U.S. MEN	4	4.5	5	5.5	6	6.5	7	7.5	8	8.5	9	9.5	10	10.5	11	11.5	12	12.5	13	13.5	14	
U.S. WOMEN	5.5	6	6.5	7	7.5	8	9	9.5	10	10.5	11	11.5	12	12.5	13	13.5	14					
EURO	36	36.5	37	37.5	38	38.5	39	39.5	40	40.5	41	41.5	42	42.5	43	43.5	44	44.5	45	45.5	46	
UK			4	4.5	5	5.5	6	6.5	7	7.5	8	8.5	9	9.5	10	10.5	11	11.5	12	12.5	13	
CM	23.1	23.5	23.8	24.1	24.5	24.8	25.1	25.4	25.7	26	26.7		27.3		27.9		28.6				29.2	
IN	9¼	9¼	9½	9½	9¾	9¾	9¾	10	10¼	10¼	10½		10¾		11		11¼				11½	

NEW BLACKTOP SHOE

Simpson's newest racing inspired multi-surface shoe for everyday wear both on and off the track is constructed of leather and suede uppers with extra comfort insoles for those long days on your feet. The Blacktop soles are designed for grip, capable of handling rocky, wet, and smooth surfaces with ease.



CODE:
BT

SIZE:
8 - 14 (INCLUDES 1/2 SIZES)

FEATURES
Extra Comfort Insoles for Long Wear
Durable Bottom Soles with Extra Grip
Order ½ size up for wide width

COLOR
Black



PIT BOX SHOE

The Pit Box shoe is engineered to meet the demands of today's over-the-wall athletes. Lightweight but extremely tough, this shoe is made to be quick & hold up to the demands of any pit crew.



CODE:
PB

SIZE:
7 - 17 (INCLUDES 1/2 SIZES)

FEATURES
SFI 3.3/5 certified
Velcro closure
Internal ankle protection
Lace protection
Durable toe guard
Speed styling and design

COLOR
Black

GARAGE CREW SHOE

Simpson's Garage Crew Shoe resists abrasion and provides traction and stability in an everyday work environment. It is all in a day's work when you wear Simpson's crew shoe. Our Garage Crew Shoe is made for superior service with an upper that features suede and abrasion-resistant canvas. A durable cushioned interior wicks away moisture, while non-marking, slip-resistant outer soles provide reliable traction.



CODE:
57000

SIZE:
4 - 14 (INCLUDES 1/2 SIZES)

FEATURES
Round soft toe and cushioned soles
Non-marking, slip-resistant outer sole

COLOR
Black

CARE
We recommend Molecule Spot Cleaner and Molecule Refresh products to keep your Simpson shoes looking their best.

*Shoe longevity varies based on user wear

FR SHOE LACES

COLOR
Black



CODE:
FRLACES

SIZE:
48"

ACCESSORIES

V02FX™ 15/20 COMPRESSION SOCKS



Available in fire-retardant and non-FR crew models. Provides increased endurance. Prevents swelling caused by extended sitting or driving. Encourages increased circulation which increases oxygenated blood to muscle tissues, tendons and joints of the lower extremities. Reduces muscle soreness and danger of blood clots. COOLMAX® moisture management fabric keeps feet cool and dry. No in-shoe sliding.



Compression Socks

CODE:
23030
23041

FITS:
SFI 3.3 FIRE-RETARDANT COMPRESSION SOCK
NON-FR CREW COMPRESSION SOCK

SIZES
M - XL

23041

23030



SFI 3.3 CarbonX® SOCKS



Knitted from patented CarbonX® yarn and flame-resistant, super-washed merino wool. Reinforced toe and heel, cushioned sole. CarbonX® is black in its pure form and cannot be dyed any other color.

CODE:
23029C

SIZE:
ONE SIZE FITS MOST

COLOR
Black

NOMEX® SOCKS



Knitted from Nomex.

COLORS
Black, White



Nomex® Socks

CODE:
23027
23032A

FITS:
ONE SIZE FITS ALL TUBE SOCKS
SFI NOMEX WHITE TUBE (IMAGE NOT SHOWN)

RACE FAST WE'LL HANDLE THE STOP

HARNESS, NETS
AND DRAG CHUTES



HARNESSES, NETS AND DRAG CHUTES

SIMPSON HARNESSES

Simpson Harnesses are SFI Approved. Upgrade to Platinum Plus Camlock Systems, Latch & Link, Sprint, Drag Racing and more. If you are particular about your harnesses, call Simpson. We will make a custom set just for you and deliver quickly.



See Page 92 for custom belt order form.



CODE
SB5.LUC.722BA

TYPE
CAMLOCK STYLE 7-POINT
W/T-BAR, 2" BLACK



CODE
SB5.LUL.722BAT

TYPE
LATCH & LINK STYLE 7-POINT
DIRT STYLE W/T-BAR, 2"-3", BLACK



CODE
SB6.LDC.722BAT

TYPE
CAMLOCK NASCAR STYLE 7-POINT
W/T-BAR, 2"-3", BLACK

HARNESSES, NETS AND DRAG CHUTES



CODE
SB6.LUC.722BAF

TYPE
CAMLOCK FORMULA STYLE 7-POINT
W/T-BAR, 2"-3", BLACK



CODE
SB.100.5A

TYPE
QUARTER MIDGET STYLE
LATCH & LINK, W/ALUMINUM
ADJUSTERS, 2", BLACK

SB.100.5

TYPE
QUARTER MIDGET STYLE
W/STEEL ADJUSTERS,
2", BLACK



CODE
SB.101.5A

TYPE
JUNIOR DRAGSTER STYLE
CAMLOCK, W/ALUMINUM
ADJUSTERS, 2", BLACK

SB.101.5

TYPE
JUNIOR DRAGSTER STYLE
CAMLOCK, W/STEEL
ADJUSTERS, 2", BLACK



CODE
SB5.51204

TYPE
LEFT SIDE RATCHET SYSTEM
ALUMINUM ADJUSTERS
DIRT TRACK STYLE, 2"-3", BLACK

SIMPSON BLACK



Simpson is offering the following SFI 16.1 models with black hardware

3" LATCH & LINK SYSTEM



CODE	TYPE
29063BK1X	55" SEAT BELT PULL DOWN BOLT-IN



3" LEVER OR ROTARY CAMLOCK SYSTEMS



CODE	TYPE
29110BKL1X	LEVER
29110BKR1X	ROTARY



CODE	TYPE
29110BKL3X	LEVER
29110BKR3X	ROTARY



CODE	TYPE
29110BKL2X	LEVER
29110BKR2X	ROTARY

HARNESSES, NETS AND DRAG CHUTES



2" LEVER OR ROTARY CAMLOCK SYSTEMS WITH CAMLOCK CLIP ADJUSTERS



CODE
29400BKL1X LEVER
29400BKR1X ROTARY



CODE
29400BKL2X LEVER
29400BKR2X ROTARY



CODE
29400BKL2X LEVER
29400BKR2X ROTARY



CODE
29400BKL3X LEVER
29400BKR3X ROTARY



ROTARY SERIES

COLORS

Black, Platinum



Rotary Series

CODE	TYPE
29118S0	PULL DOWN BOLT-IN, 6-PT, BLACK
29119S0	PULL UP BOLT-IN, 6-PT, BLACK
29218SP	PULL DOWN BOLT-IN, 6-PT, PLATINUM
29219SP	PULL UP BOLT-IN, 6-PT, PLATINUM



ROTARY SERIES WITH 2" UPPERS

Rotary Series with 2" Uppers

CODE	TYPE
29828S0	PULL DOWN BOLT-IN, 6-PT, BLACK
29829S0	PULL UP BOLT-IN, 6-PT, BLACK

LATCH FX SERIES

FEATURE

Can be made with 2" upper shoulder Harness for Head Restraints

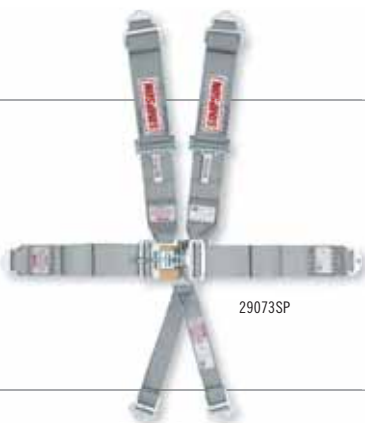

Latch FX Series

CODE	TYPE
29073S0	PULL DOWN BOLT-IN, 6-PT, BLACK
29073SP	PULL DOWN BOLT-IN, 6-PT, PLATINUM



LATCH & LINK SERIES

FEATURE

Can be made with 2" upper shoulder Harness for Head Restraints



Latch & Link Series

CODE	TYPE
29054S0	PULL DOWN BOLT-IN, 6-PT, BLACK
29055S0	PULL UP BOLT-IN, 6-PT, BLACK
29056SP	PULL DOWN BOLT-IN, 6-PT, PLATINUM
29057SP	PULL UP BOLT-IN, 6-PT, PLATINUM

HARNESSES, NETS AND DRAG CHUTES

SPORT CAMLOCKS



COLORS
Black, Blue, Red

Sport Camlocks

CODE	TYPE
29107	55" BOLT-IN SPORT CAMLOCK, 5-PT BLACK
29212	55" BOLT-IN SPORT CAMLOCK, 6-PT BLACK

29107 5-POINT



LEVER CAMLOCK TECHNOLOGY



Try our New Lever Camlock/Clip system redesigned to be 15% lighter. A unique internal release mechanism is engineered to eject belts clips quickly. Our belts clips are interchangeable with rotary camlock. These systems feature a sleek matte black finish.

FEATURE
Can be made with 2" upper shoulder Harness for Head Restraints

COLORS
Black, Blue, Red, Platinum



Lever Camlock Technology

CODE	TYPE
29114	FORMULA CAR 6-WAY PULL UP, RESTRAINT BOLT-IN
29114P	UPGRADED TO PLATINUM SERIES
29102	62" FLOOR MOUNT SEAT BELT PULL UP, RESTRAINT BOLT-IN
29102P	UPGRADED TO PLATINUM SERIES
29104	62" SEAT BELT PULL UP, RESTRAINT BOLT-IN
29104P	UPGRADED TO PLATINUM SERIES
29108	55" SEAT BELT PULL DOWN, ROLL BAR V HARNESS BOLT-IN
29108P	UPGRADED TO PLATINUM SERIES
29110	55" SEAT BELT PULL DOWN, RESTRAINT BOLT-IN
29110P	UPGRADED TO PLATINUM SERIES
29112	55" WRAP AROUND SEAT BELT, PULL DOWN RESTRAINT
29112P	UPGRADED TO PLATINUM SERIES

29114P PLATINUM SERIES



29108



29110



LATCH F/X



Compact integrated latch, link and adjuster reduces size by 30%. Drop-forged construction reduces weight by 30%. V-type or individual shoulder harnesses. Adjusters include anti-slip spring. No left side adjuster option available. Platinum Series also available.

FEATURE

Can be made with 2" upper shoulder harness for Head Restraints

COLORS

Black, Blue, Red, Platinum

Latch F/X

CODE	TYPE
29072	62" WRAP AROUND SEAT BELT, PULL DOWN RESTRAINT WRAP AROUND
29072P	UPGRADED TO PLATINUM SERIES
29073	62" SEAT BELT PULL DOWN, RESTRAINT BOLT-IN
29073P	UPGRADED TO PLATINUM SERIES
29074	62" SEAT BELT PULL DOWN, ROLL BAR V HARNES BOLT-IN
29074P	UPGRADED TO PLATINUM SERIES

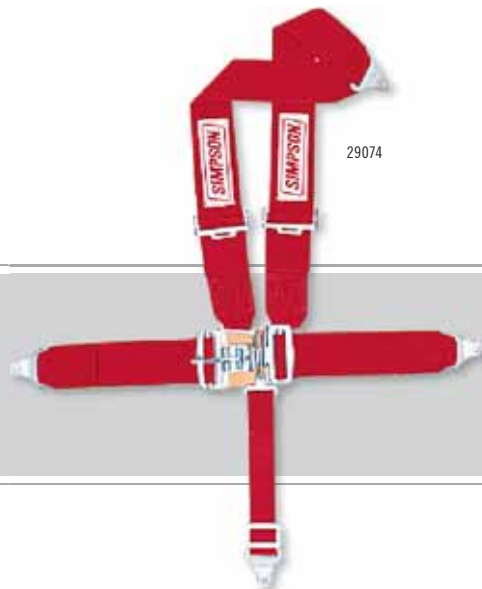

HARNESSES, NETS AND DRAG CHUTES

SPORT LATCH & LINK

Features polyester construction for maximum protection. Belts ship as a wrap around system. Separate bolt in brackets included in the box. Sport Model features the S-logo Simpson patch.

COLORS

Black, Blue, Red



Sport Latch & Link

CODE
29043

TYPE
55" BOLT-IN SPORT LATCH & LINK, 5-PT

STD. LATCH & LINK

Drop-forged alloy steel with cadmium plating. Standard 3" military specification webbing on shoulder and lap belts with heat cut and sealed ends. Pull up or pull down adjusters. V-type or Individual shoulder harnesses. Adjusters include anti-slip springs. No left side adjuster option available. Floor-mount, bolt-in seat belts, or wrap around. Platinum Series also available.

UPGRADE

Aluminum shoulder adjuster

FEATURE

Can be made with 2" upper shoulder harness for Head Restraints

COLORS

Black, Blue, Red, Platinum



29061



29063



29065



STD. Latch & Link

CODE
29061
29061P
29063
29063P
29064

29064P
29065

29065P
29066

29066P
29075

29075P

TYPE
62" SEAT BELT PULL UP RESTRAINT BOLT-IN
UPGRADED TO PLATINUM SERIES
55" SEAT BELT PULL DOWN, RESTRAINT BOLT-IN
UPGRADED TO PLATINUM SERIES
55" WRAP AROUND SEAT BELT PULL DOWN,
RESTRAINT WRAP AROUND
UPGRADED TO PLATINUM SERIES
55" SEAT BELT PULL DOWN,
ROLL BAR V HARNESS BOLT-IN
UPGRADED TO PLATINUM SERIES
SPRINT CAR BELT PULL DOWN,
NO RIGHT SIDE ADJUSTER
UPGRADED TO PLATINUM SERIES
SPRINT CAR BELT PULL DOWN, NO RIGHT
SIDE ADJUSTER W/SHORT SEW PATTERN
UPGRADED TO PLATINUM SERIES



RATCHET HARNESSES



For when the ride is especially rough and you want to keep those harnesses tightened down. Ratchet Harnesses are available in left side or right side, with Aluminum or Steel adjusters. These harnesses from our Platinum Plus line are manufactured at Simpson's North Carolina facility. In other words, like all Simpson belts, they are made in the USA!



SB.51204

Ratchet Harnesses

CODE	TYPE
SB.51201	16.1 L&L W/ STEEL ADJUSTERS, RIGHT-SIDE RATCHET
SB.51202	16.1 L&L W/ AL ADJUSTERS, RIGHT-SIDE RATCHET
SB.51203	16.1 L&L W/ STEEL ADJUSTERS, LEFT-SIDE RATCHET
SB.51204	16.1 L&L W/ AL ADJUSTERS, LEFT-SIDE RATCHET



CALL FOR ADDITIONAL CONFIGURATIONS.

JR. DRAGSTER



COLORS
Black, Blue, Red

Jr. Dragster

CODE	TYPE
35012	WRAP AROUND SEAT BELT, PULL UP ROLL BAR WRAP AROUND HARNESS



QUARTER MIDGET



COLORS
Black, Blue, Red

Quarter Midget

CODE	TYPE
29025	WRAP AROUND SEAT BELT, PULL DOWN ROLL BAR WRAP AROUND HARNESS
29026	BOLT-IN SEAT BELT, PULL DOWN INDIVIDUAL HARNESS BOLT-IN



HARNESSES, NETS AND DRAG CHUTES

7 POINT DRAG CAMLOCK



Simpson Drag Restraints are SFI 16.1 Rated. Our belts are manufactured using polyester webbing for strength and durability. Bolt-in individual shoulder harness (18"). Lap belt has pull up adjustments on right and left side bolt-in. Formula style sub-belts with additional sub-belt to make 7th point. Nomex® covered.



7 Point Drag Camlock

CODE	TYPE
29115BK	FUNNY CAR RESTRAINT, BLACK
29115P	FUNNY CAR RESTRAINT, PLATINUM



29115BK

5 AND 7 POINT DRAG CAMLOCK



Drag Racing 5-way restraint covered with Nomex®

COLORS
Black, Blue, Red and Platinum upgrade

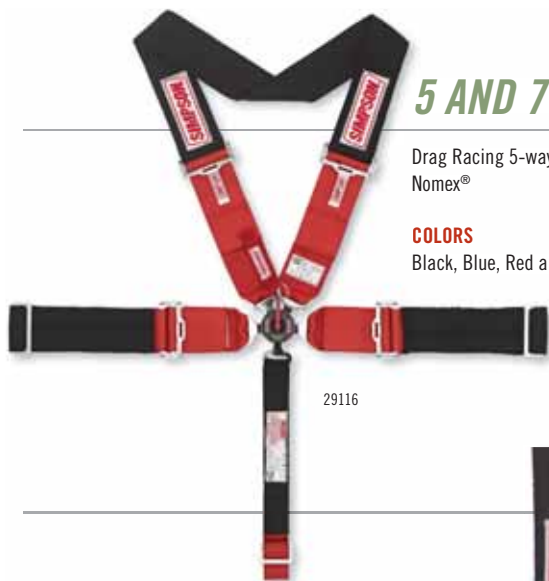

29116

5 and 7 Point Drag Camlock

CODE	TYPE
29116	5-POINT RESTRAINT
29116P	5-POINT RESTRAINT, PLATINUM
29116M	7-POINT RESTRAINT, SINGLE SHOULDER
29110M	7-POINT RESTRAINT, INDIVIDUAL SHOULDERS

STERNUM BUCKLE

SHOULDER HARNESS
SOLD SEPARATELY



CODE:	TYPE:
PSTERNUMSTRAP	OFF-ROAD



SEATBELTS

MOUNTING HARDWARE

Simpson offers 3 types of restraint mounting hardware: Bolt-in (left), Wrap Around (center), Floor Mount (right).



NOT SHOWN TO SCALE.
FOR CONFIGURATION DEMONSTRATION ONLY.

CODE	TYPE
31022	BOLT-IN BRACKET, 2 EACH
31019	3" BAR SLIDE ADJUSTERS, 2 EACH
31020	FLOOR MOUNTING KIT, 2 EACH
31018	EYE BOLT KIT, EYEBOLT, NUT & WASHER

LATCH FX SEATBELT

PULL DOWN ADJUSTMENT



CODE	TYPE
29030	62" FLOOR MOUNT, ADJUSTMENT TO 36"
29032	62" WRAP AROUND, ADJUSTMENT TO 32"
29034	62" BOLT IN, ADJUSTMENT TO 32"

COLORS: Black, Blue, Red, Platinum Series Upgrade Available

LATCH AND LINK SEATBELT

PULL UP ADJUSTMENT



CODE	TYPE
29000	62" FLOOR MOUNT, ADJUSTMENT TO 36"
29002	62" WRAP AROUND, ADJUSTMENT TO 32"
29004	62" BOLT-IN, ADJUSTMENT TO 32"

COLORS: Black, Blue, Red, Platinum Series Upgrade Available

PULL DOWN ADJUSTMENT



CODE	TYPE
29020	55" FLOOR MOUNT
29022	WRAP AROUND, ADJUSTMENT TO 24"
29024	55" BOLT-IN

COLORS: Black, Blue, Red, Platinum Series Upgrade Available

CAMLOCK SEATBELT

PULL UP ADJUSTMENT



CODE	TYPE
32000	62" FLOOR MOUNT
32002	62" WRAP AROUND
32004	62" BOLT-IN, ADJUSTMENT TO 36"

COLORS: Black, Blue, Red, Platinum Series Upgrade Available

PULL DOWN ADJUSTMENT



CODE	TYPE
32020	55" FLOOR MOUNT
32022	55" WRAP AROUND
32024	55" BOLT-IN

COLORS: Black, Blue, Red, Platinum Series Upgrade Available



HARNESSES AND ANTI-SUB BELTS

DUAL ANTI-SUB BELTS

Semi-adjustable. Measures 27" per side. Bolt-in installation. Fits CamLock or Latch Type buckle.



CODE
34014 TYPE **CAMLOCK**
31014 TYPE **LATCH TYPE**

COLORS: Black, Blue, Red, Platinum Series Upgrade Available

ROLLBAR MOUNT

Compatible with SFI 38.1 Head and Neck restraint. 3" V-type shoulder harness attaches to any belt. V belt length from bolt-in mounting bracket to the buckle has adjustable length of 24 to 33 inches.



CODE
33005 TYPE **CAMLOCK**
30005 TYPE **LATCH TYPE**

COLORS: Black, Blue, Red, Platinum Series Upgrade Available

ANTI-SUBMARINE BELTS



CODE
34012 TYPE **CAMLOCK BOLT-IN**
31012 TYPE **LATCH TYPE BOLT-IN**
34013 TYPE **CAMLOCK FLOOR MT.**
31013 TYPE **LATCH TYPE FLOOR MT.**

COLORS: Black, Blue, Red, Platinum Series Upgrade Available

Semi-adjustable
 27" long
 Adjustable Pull-up
 Bolt-in mounting



CODE
34015 TYPE **CAMLOCK**
31015 TYPE **LATCH TYPE**

COLORS: Black, Blue, Red, Platinum Series Upgrade Available

SHOULDER HARNESS HEAD & NECK RESTRAINT COMPATIBLE

Compatible with SFI 38.1 Head and Neck restraint. Individual shoulder harnesses. 48" length adjusts down to 24". Shoulder harness 2" (shown).



CODE
33010 TYPE **CAMLOCK**
30010 TYPE **LATCH TYPE**

COLORS: Black, Blue, Red, Platinum Series Upgrade Available

HEAD AND NECK RESTRAINT DUAL HARNESS

CODE
33011 TYPE **CAMLOCK DUAL**
30011 TYPE **LATCH & LINK, DUAL WRAP AROUND**

COLORS: Black, Blue, Red, Platinum Series Upgrade Available

SHOULDER HARNESS

Individual shoulder harnesses. 48" long and adjust down to 24". Bolt-in or wrap around style.



CODE
33004 TYPE **CAMLOCK**
30004 TYPE **LATCH TYPE BOLT-IN**

COLORS: Black, Blue, Red, Platinum Series Upgrade Available

STERNUM BUCKLE

Holds shoulder harness together. For CamLock or standard Latch & Link seat belts. NOT SOLD SEPARATELY. Can only be added at time of belt purchase. Order harness part number and add Sternum Protector.



CODE
PSTERNUMSTRAP

FLOOR MOUNT INDIVIDUAL HARNESS 75" (Not Shown)

CODE
33009 TYPE **CAMLOCK**
30009 TYPE **LATCH TYPE**

COLORS: Black, Blue, Red, Platinum Series Upgrade Available



TIE DOWNS AND RESTRAINTS

HELMET RESTRAINTS

Fatigue-reducing helmet strap
Quick attachment and adjustment
Durable steel hardware, helmet
"D-ring" installation



CODE TYPE
36007 **HELMET RESTRAINT**

COLORS: Black, Blue, Red

RATCHET TIEDOWNS

High-strength ratchet tie-downs secure racing vehicle to trailer or transporter
2" polyester webbing featuring a ratcheting buckle with integral hook and snap hook
at opposite end
Convenient and easy to use, these tie-downs go on and off with a few flicks of the wrist
Sold in pairs, each piece 8' long



CODE TYPE
35007 **RATCHET TIE DOWN (PAIR)**

COLORS: Black, Blue, Red

ROLLBAR PADDING

Open Cell Urethane padding comes in 36" sections
"C" shaped to fit 1 5/8" to 2" tubing
WILL NOT DRIP OR MELT
Meets SFI 45.1
Impact test proven effective



CODE TYPE
36008 **SFI 45.1 EMBOSSED IN PADDING**

COLOR: Black

SHIFT BOOT COVER

Simpson leads the way in racing safety once again with our reinforced shift boot cover,
equipped with an innovative top seal Kevlar strap and D-Ring fastener designed to
control the spread of a fire from underneath the car into the cockpit area.

SFI 48.1 approved
Made with Nomex®
Reverse Stitching Nomex® thread seam
Kevlar interior for added protection
Base: 7.25" x 6.25"



CODE TYPE
36012 **SHIFT BOOT COVER**

Color: Black only

NOMEX® HARNES PADS

Attaches with speedfit to shoulder harness or lap belt
Tighten down your belts in comfort



CODE TYPE
230210 **HARNES PADS (PAIR)**

COLORS: Black, Blue, Red

AXLE RATCHET TIE DOWN W/D-RING

8' long tie down provides additional security via axle or rear-end
2" polyester webbing features a ratcheting buckle with integral hook and sail hook
that fastens into a D-ring
Sold individually



CODE TYPE
35009 **AXLE RATCHET TIE DOWN (EACH)**

COLORS: Black, Blue, Red

AXLE STRAPS

Ties down racing vehicle via axle or wrap around the frame
24" long with 2" webbing
D-rings on both ends



CODE TYPE
35010 **AXLE STRAP (EACH)**
35008 **15' TOW STRAP (EACH)**
35011 **LIMITER STRAP (EACH)**

COLORS: Black, Blue, Red

ARM RESTRAINTS

Meets SFI 3.3.
A must for Sprint, Midget
and Off-Road racing.
Features padded arm bands
and steel hardware.
Easy release allows quick entry and exit from driver's compartment.



CODE TYPE
36000 **ARM RESTRAINT W/ INDIVIDUAL STRAPS**
36001 **ARM RESTRAINTS W/Y STRAPS**
J3600 **JR. ARM RESTRAINT W/ INDIVIDUAL STRAPS**
AVAILABLE WITH "Y" STRAPS AS CUSTOM ORDER
COLORS: Black, Blue, Red

54018 **INDIVIDUAL REPLACEMENT STRAPS**
FOR BUILT-IN ARM RESTRAINT

AR.QTM **JR. ARM RESTRAINTS (VELCRO)**
AR.ADU **ADULT ARM RESTRAINTS (VELCRO), BLACK ONLY**



NETS AND ACCESSORIES

LEFT SIDE MOUNT CAGE NET

SFI 37.1 approved. Webbing tensile strength is 6,000 lbs. Fits up to 58" between "A" post and roll cage behind seat. Wraps around seat to support Head rest and shoulder. Helps keep driver in proper position and provides extra barrier behind window net.



CODE
36016

TYPE
LEFT SIDE MOUNT

COLOR: Black

RIGHT SIDE MOUNT CAGE NET

SFI 37.1 approved. Webbing tensile strength is 6,000 lbs. Fits up to 58" between dash bar and roll cage behind seat. Wraps around seat to support Head rest and shoulder. Helps keep driver in proper position during crash.



CODE
36015

TYPE
RIGHT SIDE MOUNT

COLOR: Platinum

SPRINT/MIDGET NET

Meets SFI 37.1. Window nets for Sprints, Midgets and Quarter Midgets. 1" webbing with quick release buckle.



CODE
36005
J36005
36006

TYPE
SPRINT
QUARTER MIDGET
CHAMP CAR

COLORS: Black, Blue, Red

C5R DRIVER NET

Our original red handle nets adapt to all makes and models of race cars. SFI 37.1 Approved. Available in Kevlar or Polyester. Quick Release Design. The CR5s special design keeps it out of the field of vision while providing side and angular impact protection.



CODE
DN.C5R.RK
DN.C5R.LK
DN.C5R.RP
DN.C5R.LP

TYPE
RIGHT SIDE KEVLAR
LEFT SIDE KEVLAR
RIGHT SIDE POLY
LEFT SIDE POLY

GRAND AM KEVLAR NET



CODE
DN.GRD.RK
DN.GRD.LK

TYPE
RIGHT SIDE KEVLAR
LEFT SIDE KEVLAR

SPRINT CAR NET



CODE
DN.SPR.RK
DN.SPR.LK
DN.SPR.RP
DN.SPR.LP

TYPE
RIGHT SIDE KEVLAR
LEFT SIDE KEVLAR
RIGHT SIDE POLY
LEFT SIDE POLY



NETS AND ACCESSORIES

KART BRACE

Dual foam layers provide a protective inner core with a comfortable outer shell and an abrasion-resistant fabric lining. Rigid SFI 45.2 impact rated foam reduces neck flexion and head rotation during impact.



CODE
KARTBRACE. LW

TYPE
ADULT AND YOUTH SIZE AVAILABLE

COLOR: *Black*

PADDED NECK SUPPORT

SFI tag included, SFI 3.3 approved. Reduces Neck fatigue for any racer. Removable knit Nomex® sleeve. One size with adjustable speedfit fasteners (*can be custom fit*).



CODE
23022

TYPE
RED

23022

BLUE

23022

BLACK

COLORS: *Black, Blue, Red*

PADDED NECK COLLAR

Head and Neck restraint compatible.
SFI 45.2 Padding



CODE
NC.CHD.YTH
NC.SML
NC.MED
NC.LRG

COLOR: *Black*

WINDOW NET

Standard, NASCAR or Custom
Meets SFI 27.1. Stock Car type and square window nets for full-bodied cars.
Stock Car type is 16" x 27" trapezoid with 1" webbing.

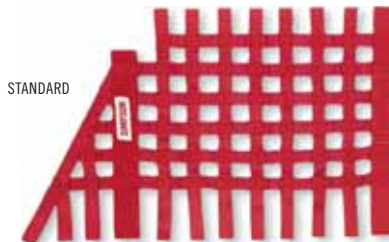

STANDARD

CODE
36002
36003
36004
36013

TYPE
18" X 24" RECTANGLE
24" X 24" SQUARE
16" X 27" TRAPEZOID
CUSTOM NET SEND TEMPLATE

COLORS: *Black, Blue, Red*

NASCAR,
OFFERED IN BLACK ONLY



CODE
NASCAR

TYPE
NASCAR NET, BLACK ONLY

CHIN STRAPS



CODE
RH.DCS
DRC.SS
DRC.CS

TYPE
DOUBLE CHIN STRAP "W"
SINGLE CHIN STRAP
CENTERING CHIN STRAP

OFF-ROAD NECK COLLAR

WITH OR
WITHOUT FLANGE



CODE
NC.OR
NC.ORF

TYPE
OFF-ROAD
OFF ROAD W/FLANGE (AS SHOWN)

HARNESSES, NETS AND DRAG CHUTES

12' CROSSFORM DRAG CHUTE



Designed for Funny Cars and Dragsters. Handmade Crossform design for outstanding performance from 200 to 300+ mph. Complete with aluminized pack and pilot chute.

COLORS

Black, Blue, Red, Golden Yellow



CODE:
42060

TYPE:
CROSSFORM DRAG CHUTE

CALL FOR QUOTE TO ADD CUSTOM LETTERS AND/OR LOGO.

10' SKY JACKER DRAG CHUTE



Handmade Crossform design delivers reliable and durable performance for all cars up to 200 mph. Complete with black nylon pack and pilot chute.

COLORS

Black, Blue, Red, Golden Yellow. Custom colors available.



CODE:
42020

TYPE:
SKY JACKER DRAG CHUTE

CALL FOR QUOTE TO ADD CUSTOM LETTERS AND/OR LOGO.

14' PROFESSIONAL SERIES



Our largest 14' parachute canopy. All Kevlar chute and shroud line construction. 20% lighter than traditional nylon chute. Kevlar translates to increased speed and a safer racing environment. Increased fire protection. Handmade in the USA, cross form design for top performance at speeds of 300+ mph. Ships complete with pack and pilot chute.



14' Professional Series

CODE	TYPE
42055	14' KEVLAR CHUTE WITH KEVLAR® SHROUD LINES <i>Color: Yellow Only</i>
42050	14' PREMIUM NYLON CHUTE WITH KEVLAR® SHROUD LINES <i>Colors: Black, Blue, Red and Golden Yellow</i>

CALL FOR QUOTE TO ADD CUSTOM LETTERS AND/OR LOGO.

Kevlar® Parachutes are 20% Lighter

8 FT. OUTLAW SKY JACKER DRAG CHUTE



Made in the USA. 4 Lightweight Kevlar Shroud Lines make the Outlaw chute the number 1 choice for drag racers looking to reduce their weight load. Professional series stopping power, quality construction. Handmade crossform chute delivers reliable performance for cars up to 200 mph. Ships with pack and pilot chute.



COLORS

Black, Red, Blue, Golden Yellow

8 ft. Outlaw Sky Jacker Drag Chute

CODE 42038	TYPE 8' DRAG CHUTE FEATURING KEVLAR SHROUD LINE CONSTRUCTION
---------------	--

CALL FOR QUOTE TO ADD CUSTOM LETTERS AND/OR LOGO.

AIR BOSS PARACHUTE 10 FT.



COLORS

Black, Blue, Red, Golden Yellow



FEATURES

Pneumatic Launcher Style
Designed for applications where a launcher style chute is necessary
Canopy Size: Order 8' or 10' chute
Four Kevlar lines for added protection
Chutes manufactured in the USA
Quality craftsmanship
Team and Sponsor logos can be added (*call for pricing*)
Simpson race day service and support still going strong

Air Boss Parachute 10 Ft.

CODE	TYPE
42040	10' CHUTE
42041	10' CHUTE/LAUNCHER
42042	10' DUAL AIR BOSS, CHUTE/LAUNCHER
42043	10' LAUNCHER SYSTEM
42044	10' DUAL LAUNCHER SYSTEM
42045	BLACK NOMEX® CHUTE PACK, 10' AIR BOSS
42046	BLACK PILOT BAG, 10' AIR BOSS

AIR BOSS PARACHUTE 8 FT.

Air Boss Parachute 8 Ft.

CODE	TYPE
42030	8' CHUTE
42031	8' CHUTE / LAUNCHER
42032	8' DUAL AIR BOSS, CHUTE / LAUNCHER
42033	8' LAUNCHER SYSTEM
42034	8' DUAL LAUNCHER SYSTEM
42035	BLACK NYLON CHUTE PACK, 8' AIR BOSS
42036	BLACK PILOT BAG, 8' AIR BOSS

MINI DRAGSTER PARACHUTE AND CHUTE ACCESSORIES (NOT SHOWN)

Mini Dragster Parachute and Chute Accessories

CODE	TYPE
42082	MINI DRAGSTER CHUTE
42085	PILOT CHUTE (ALL MODELS)
42087	CROSSFORM PACK
42086	SKY JACKER PACK



CHUTE FLAG TWO SIDED

CODE:
CHUTEFLAG

Simpson Branded. Two Sided Chute Flag. Simpson Red.

HARNESSES, NETS AND DRAG CHUTES

NEW AVIATION HARNESSES



Simpson Performance Products manufactures 5, 6 and 7-point aviation harnesses for experimental planes, aerobatic planes, torical/military and historical/military restoration planes. We offer our most popular configurations along with fully customized harnesses stylized to the owner's specifications. Simpson aviation harnesses are made in the US specifications. Simpson aviation harnesses are made in the USA and backed by Simpson's 60 years of experience and research in motorsports safety.



Studies of serious accidents have shown that the proper use of shoulder harnesses, in addition to the safety belt, can reduce major injuries by 88 percent, and fatalities by 20 percent.

Simpson's own research shows us that the use of a 5, 6 or 7-point harness can have a major impact on occupant safety. After a number of auto racing fatalities in the 90s, Simpson Engineering went to the labs and established a library of proven practices that save lives.



7 POINT SOLUTIONS

6 POINT SOLUTIONS

SIMPSON RESTRAINT PHILOSOPHY

1. Restraining the pelvis reduces torso and head injury numbers.
2. For optimum restraint, use 5, 6 or 7-point harnesses, no 4-point systems. Use quick-release camlock systems. Do not use retractors.
3. All Simpson restraint systems use Polyester webbing over Nylon for superior performance in stretch and longevity.
4. Apply data for a significantly higher performance rating.

STREET CRED

NOW AVAILABLE IN MULTIPLE SIZES

APPAREL AND GEAR

APPAREL AND GEAR

BAGS

NEW STILO BACKPACK / ZAINETTO

CODE:
YA0017S

SIZE:
18" L X 16" W X 8" D



*SUPER SPEEDWAY
ROLLER BAG*

CODE: 23303
SIZE: 33.5" L X 18" W X 16.5" H



*SPEEDWAY
BAG*

CODE: 23301
SIZE: 27" L X 13" W X 17" H

*RACING SUIT
TOTE BAG*



CODE:
23306

*RACEWAY
BAG*



CODE: 23304
SIZE: 20" L X 11" W X 13" H



PIT PACK

CODE: 23307
SIZE: 18" L X 13" W X 10" D



*PLUSH
HELMET BAG*

CODE:
23305

SIMPSON BRANDED APPAREL FOR 2019

Whether it is a cool night at Chili Bowl, cruising the midway at Indy Nationals, a memorable trip to the Daytona 500 or tuning your race car at home, Simpson apparel is designed to come along for the ride.



59 HOODIE RED

CODE:	SIZE:	COLOR:
44904	S - XXL	RED



CLASSIC HOODIE

CODE:	SIZE:	COLOR:
44008	S - XXL	BLACK

ALL-TERRAIN JACKET

Weather-resistant outer with warm fleece inner. A lightweight jacket that helps to keep you warm and dry.



CODE:	SIZE:	COLOR:
43094	S - XXL	BLACK WITH WHITE LOGOS



APPAREL AND GEAR

HATS

DNA PERFORMANCE HAT



DNA Performance Hat

CODE	SIZE	COLOR
430741	S/M	BLACK/GREY
430742	L/XL	BLACK/GREY
430731	S/M	BLACK/RED
430732	M/XL	BLACK/RED



SIMPSON TEAM HAT

CODE:	SIZE:	COLOR:
44010	S/M, L/XL	BLACK/RED

LOW PROFILE 60TH ANNIVERSARY VINTAGE HAT



CODE:	SIZE:	COLOR:
449101	ONE SIZE ADJUSTABLE	RED



VINTAGE HAT

CODE:	SIZE:	COLOR:
440193	SNAP BACK ADJUSTABLE	BLACK/MULTI STRIPE

TEES

60TH ANNIVERSARY
SPECIAL EDITION TEES

CODE: 44901 SIZE: S - XXL

Colors: White, Black, Red



FRONT

FRONT

FRONT

USA FLAG TEE

CODE: 44018 SIZE: S - XXL

Color: Black



BACK

FRONT

LOGO TEE

CODE: 44903 SIZE: S - XXXL

Color: Black



FRONT

LADIES TEE

CODE: 44020 SIZE: XS - 2XL

Color: Black



FRONT

BACK

CHAMPION TEE

CODE: 44902 SIZE: S - XXXL

Color: Black



FRONT

NEW STILO TEE

CODE: YY0022 SIZE: S - XXL

Color: Grey

Check website for additional styles



BACK

FRONT

VINTAGE TEE

CODE: 44006 SIZE: S - XXL

Color: Black



FRONT

SIMPSON



Shop for other motorcycle full face helmets on our website.