

BREAK

FROM THE

PACK

**SIMPSON**



**PERFORMANCE**  
RACE ENGINES

**WOLF**  
**PACK**

RACE CARS • PARTS  
CONSULTING

**RACING HELMETS** 05

**STILO HELMETS** 19

**MOTORCYCLE HELMETS** 22

**HEAD RESTRAINTS** 25

**RACING SUITS** 35

**GLOVES** 61

**SHOES** 66

**HARNESSES** 72

**OFF-ROAD SEATS** 92

 **CHARLOTTE** 

## **BREAK FROM THE PACK**

Whether you stand out because you're leading the way or because you're paving your own path, Simpson is there to make sure you can race and ride the way you want.

Our gear doesn't just meet standards, it sets them. We're constantly innovating our helmets, restraints, harnesses, suits, gloves and shoes to provide an unparalleled level of comfort, performance and protection.

Racing and riding are more than what you do, it's a part of who you are. We get that, because it's who we are too.

Break from the pack with Simpson.

**SIMPSON**<sup>®</sup>



## SNELL 2015 RACING HELMETS

Snell SA rating is the most widely accepted standard for racing helmet safety in the world.

The Snell standard is updated once every five years, generally improving helmet protection each time.

Effective October 1, 2015, helmet manufacturers began selling Snell 2015 rated helmets, meeting Snell's latest and most stringent safety standards.

The helmets are clearly marked with the Snell 2015 safety label.

### AN OVERVIEW OF THE IMPROVEMENTS TO THE SA2015 STANDARD VERSUS THE SA2010 STANDARD IS EXPLAINED HERE.

*SA2015 helmets are equipped with FIA 8858-2010 compliant M6 terminal mounts for head restraints. Head restraints such as the widely used HANS and Hybrid styles have been credited as being the number one lifesaving advance in personal racing safety equipment of the last 20 years.*

*SA2015 includes provisions for Low Velocity impact testing. For the racer, this test ensures performance in low velocity crashes.*

*A single helmet is tested in five separate sites on a flat anvil on or above the helmet's test line.*

*No impact may exceed 200G and the average of the five peaks must not exceed 180G.*

*SA2015 includes Low Lateral impacts at the intersection of the head form reference and transverse planes. This is the key area around the ear and temple.*

*The peak G criteria for helmets tested on head forms of less than 60 cm circumference (ISO A-J) has been raised to 300 G and the velocity of the first impact has been increased to 8.5 m/sec. Second impact velocities have been reduced.*

*The peak G criterion for the ISO M head form remains at 264 G, but the first impact velocity has been increased to 8.0 m/sec.*

*The second impact velocity has been reduced.*

*SA2015 certification will require two more helmet samples than SA2010 demanded. One of these is for the FHR testing and the other for the additional impact tests.*

Generally racers wear what is required by their sanctioning bodies. Each sanctioning body establishes which standards it will accept and how old the rating can be. Be sure to keep up with your sanctioning body and local track requirements.

## CERTIFICATIONS



**FIA:** The Fédération Internationale de l'Automobile (FIA), Headquartered in Paris, France, is a nonprofit organization that brings together 227 national motoring and sporting organizations from 132 countries on five continents. FIA Formula One World Championship, FIA World Rally Championship and FIA World Touring Car Championship are among the sanctioning bodies who abide by FIA standards.



**SFI:** The SFI Foundation, Inc. (SFI) is a nonprofit organization established to issue and administrate safety standards for specialty and performance of automotive and racing equipment. SFI oversees testing and standards for racing suits, restraints and many other high-performance safety products in the United States. NASCAR, SCCA, IRL and NHRA are among the sanctioning bodies who abide by SFI standards.



**Snell:** Snell Memorial Foundation is known for its ongoing work in setting, maintaining and continually upgrading helmet standards in Motorsports in the world. NASCAR, NHRA, SCCA and IRL are among the sanctioning bodies who abide by Snell helmet standards.



**DOT:** United States Department of Transportation – meets US DOT requirements for motorcycle helmets.



**ECE 22.05:** Economic Community of Europe (ECE) is the most common helmet standard used internationally. The ECE 22.05 is required by over 50 countries worldwide.

RACING HELMETS

TRADE PAINT  
BUT STEAL  
POSITION



# RACING HELMETS

## CARBON EV1

Exceptionally lightweight Auto Clave molded Carbon Fiber construction

### FEATURES

1/3 pound lighter than composite Vudo EV1  
Recessed eye port ensures 100% shield seal  
Head Restraint-ready  
Includes padded helmet bag  
Radio communications may be added



CODE:  
**663C**

SIZE:  
**7 1/8 - 7 3/4**

### RECOMMENDED FOR REPLACEMENT SHIELDS 101 SERIES

Circle Track	CODE: 1010-17	COLOR: CLEAR
Dirt Track	CODE: 1011-17	COLOR: SMOKE
Drag	CODE: 1012-17	COLOR: AMBER
Karting	CODE: 1013-17	COLOR: IRIIDIUM
Off-Road	CODE: 1014-17	COLOR: MIRROR
Road Racing		

*New 101 Series injection molded shields provide exceptional clarity and no distortion.*

TOP SIDE AIR OPTIONS AVAILABLE RIGHT  
CODE: 97032  
LEFT CODE: 97033



## CARBON AIR INFORCER VUDO

Made from exceptionally lightweight, Auto Clave Molded Carbon Fiber

### FEATURES

1/3 lbs. lighter than composite Air Inforcer Vudo  
Design features include a stylish top cap designed for better pipe placement and a low profile for multiple roof/driver height  
Recessed eye port offers a 100% shield seal  
Radio communications may be added  
Includes helmet bag  
Head Restraint-ready



CODE:  
**662C**

SIZE:  
**7 1/8 - 7 3/4**

### RECOMMENDED FOR REPLACEMENT SHIELDS 101 SERIES

Circle Track	CODE: 1010-17	COLOR: CLEAR
Dirt Track	CODE: 1011-17	COLOR: SMOKE
Off-Road	CODE: 1012-17	COLOR: AMBER
Road Racing	CODE: 1013-17	COLOR: IRIIDIUM
	CODE: 1014-17	COLOR: MIRROR

*New 101 Series injection molded shields provide exceptional clarity and no distortion.*

## CARBON DEVIL RAY

The Devil Ray has an exceptionally lightweight carbon shell that weighs in at 2.9 lbs. for size Medium

### FEATURES

FIA 8859 2015 and Snell SA2015 Certified  
Radio communications may be added  
Top air and side pipe options available.  
Head Restraint-ready  
Includes padded helmet bag



CODE:  
**683C**

SIZE:  
**XS - XXL**

### RECOMMENDED FOR REPLACEMENT SHIELDS 84300 SERIES

Circle Track	CODE: 84300A	COLOR: CLEAR
Dirt Track	CODE: 84301A	COLOR: SMOKE
Drag	CODE: 84304A	COLOR: AMBER
Karting	CODE: 84303	COLOR: IRIIDIUM
Off-Road	CODE: 84306A	COLOR: MIRROR
Road Racing		

FORCED AIR TOP OFFSET

RIGHT CODE: 97032  
LEFT CODE: 97033



FORCED AIR TOP  
CODE: 97034



FORCED AIR SIDE  
CODE: 97009



DEVIL RAY PEAK  
CODE: PEAKDR





## CARBON BANDIT

Classic Bandit flagship design, improved aerodynamics through design innovation.

### FEATURES

FIA 8859-2015 approved. Snell SA 2015 certified.

Radio communications may be added  
Side pipe option available  
Includes helmet bag  
Head Restraint-ready



CODE: <b>620C</b>	TYPE: <b>CARBON BANDIT</b>	SIZE: <b>XS-XXL</b>
----------------------	-------------------------------	------------------------

CODE: <b>622C</b>	TYPE: <b>CARBON DRAG BANDIT</b>	SIZE: <b>XS-XXL</b>
----------------------	------------------------------------	------------------------

<b>RECOMMENDED FOR</b>	<b>REPLACEMENT SHIELDS</b>	<b>89400 SERIES</b>
Circle Track	CODE: 89400A	COLOR: CLEAR
Dirt Track	89401A	SMOKE
Off-Road	89402A	IRIDIUM
Road Racing	89403	AMBER
	89406A	MIRROR



**FORCED AIR SIDE**  
CODE: 97009

**FORCED AIR TOP (NOT SHOWN)**  
CODE: 97027CLR

## CARBON DIAMONDBACK

The Carbon Diamondback is Snell SA 2015 RATED and manufactured in the USA of exceptionally lightweight, Auto Clave Molded Carbon Fiber.

### FEATURES

Defined Wave Eliminators for reduced buffeting  
Optimally designed shield pivot system  
Recessed eye port offers a 100% shield seal  
Radio communications may be added  
Side pipe air option available  
Helmet bag included  
Head Restraint-ready



CODE: <b>629C</b>	SIZE: <b>7 1/8 - 7 3/4</b>
----------------------	-------------------------------

<b>RECOMMENDED FOR</b>	<b>REPLACEMENT SHIELDS</b>	<b>102 SERIES</b>
Circle Track	CODE: 1020-12	COLOR: CLEAR
Dirt Track	1021-12	SMOKE
Drag	1022-12	AMBER
Karting	1023-12	IRIDIUM
Off-Road	1024-12	MIRROR
Road Racing		

## VENATOR CARBON FIBER

The Venator features a plush interior with gel ear cups and optional padded ear inserts.

### FEATURES

FIA 8859-2015 approved. Snell SA 2015 certified.

Plush interior with Simpson branding on cheeks

Available with inside and outside seams  
Gel ear cups and optional padded ear inserts  
Head Restraint-ready

Includes padded helmet bag  
Radio communications may be added  
Top air and side pipe options available



CODE: <b>685C</b>	TYPE: <b>VENATOR CARBON FIBER</b>	SIZE: <b>XS-XXL</b>
----------------------	--------------------------------------	------------------------

<b>RECOMMENDED FOR</b>	<b>REPLACEMENT SHIELDS</b>	<b>84500 SERIES</b>
Circle Track	CODE: 84500	COLOR: CLEAR
Dirt Track	84501	SMOKE
Drag	84502	AMBER
Karting	84503	IRIDIUM
Off-Road	84504	MIRROR
Road Racing		

CODE: <b>686C</b>	TYPE: <b>VENATOR PRO FIA 8860</b>	SIZE: <b>XS-XL</b>
----------------------	--------------------------------------	-----------------------

FIA 8860-2015 approved. Snell SA 2015 certified.



**FORCED AIR TOP (NOT SHOWN)**  
CODE: 97027

**FORCED AIR SIDE (NOT SHOWN)**  
CODE: 97009

METRIC SIZE	54 CM	56 CM	57 CM	59 CM	60 CM	62 CM
HELMET SIZE	XS	S	M	M/L	L	XL

## RALLY HELMET



The Simpson Rally Helmet is FIA 8859-2015 approved and features adjustable earmuffs that deliver a soundproof environment for the ultimate race communication experience. The microphone flex boom and audio plug are factory integrated into the helmet shell and interior for maximum stability, adjustment and communications delivery. The adjustable peak height offers ultimate protection from blinding sunlight. An additional sunscreen visor can be added.

### FEATURES

FIA 8859-2015 approved, Snell SA 2015 rated  
Material is exclusive MSF structure (Multi Sandwich Fibers) with Kevlar reinforcement  
Ships with HANS anchors installed  
WRC top level integrated and adjustable earmuffs and flexboom microphone  
Adjustable peak height, optional adjustable short visor

CODE:  
**635**

SIZE:  
**XS-XL**

### SIZES

XS (54 CM)  
S (55 CM)  
M (57 CM)  
L (59 CM)  
XL (61 CM)

### TINTED VISORS AVAILABLE

CODE:	COLOR:
YA0141	DARK SMOKE
YA0142	DARK SILVER
YA0143	DARK IRIDIUM BLUE
YA0140	AMBER

### REPLACEMENT PEAKS

CODE:	COLOR:
YA0136	BLACK PEAK
YA144	WHITE PEAK

## SPEEDWAY SHARK



The Speedway Shark helmet has defined wave eliminators for reduced buffeting.

### FEATURES

Head Restraint-ready  
Includes helmet bag  
Radio communications may be added

### COLORS

White, Gloss Black, +30 Matte Black, Blue, Red, Safety Orange, Silver and Pearl White



CODE:  
**670**

SIZE:  
**7 1/8 - 7 3/4**

### RECOMMENDED FOR

Circle Track  
Dirt Track  
Karting  
Off-Road  
Road Racing

### REPLACEMENT SHIELDS 101 SERIES

CODE:	COLOR:
1010-17	CLEAR
1011-17	SMOKE
1012-17	AMBER
1013-17	IRIDIUM
1014-17	MIRROR

*New 101 Series injection-molded shields provide exceptional clarity and no distortion.*

## AIR INFORCER SHARK



Design features include a stylish top cap designed for better pipe placement and a low profile for multiple roof/driver height.

### FEATURES

Recessed eye port offers a 100% shield seal  
Radio communications may be added  
Includes helmet bag  
Head Restraint-ready

### COLORS

White, Gloss Black, +30 Matte Black, Blue, Red, Safety Orange, Silver and Pearl White

CODE:  
**677**

SIZE:  
**7 1/8 - 7 3/4**

### RECOMMENDED FOR

Circle Track  
Dirt Track  
Off-Road  
Road Racing

### REPLACEMENT SHIELDS 101 SERIES

CODE:	COLOR:
1010-17	CLEAR
1011-17	SMOKE
1012-17	AMBER
1013-17	IRIDIUM
1014-17	MIRROR

*New 101 Series injection-molded shields provide exceptional clarity and no distortion.*



### WRAP AROUND AIR

Wrap around constructed from Auto Clave molded carbon fiber.  
CODE: 97058



## AIR INFORCER VUDO

Design features include a stylish top cap designed for better pipe placement and a low profile for multiple roof/driver height.

### FEATURES

Recessed eye port with 100% shield seal  
Head Restraint-ready  
Radio communications may be added  
Includes a helmet bag

### COLORS:

White, Gloss Black, +30 Matte Black, Blue, Red, Safety Orange, Silver and Pearl White



CODE: **662** SIZE: **7 1/8 - 7 3/4**

### RECOMMENDED FOR REPLACEMENT SHIELDS 101 SERIES

Circle Track	CODE: 1010-17	COLOR: CLEAR
Dirt Track	1011-17	SMOKE
Off-Road	1012-17	AMBER
Road Racing	1013-17	IRIDIUM
	1014-17	MIRROR

*New 101 Series injection-molded shields provide exceptional clarity and no distortion.*



## VUDO EV1

The Vudo EV1 features a chin bar that offers excellent coverage.

### FEATURES

Shield pivot system opens and closes with ease.  
A recessed eye port offers 100% shield seal.  
Radio communications may be added  
Includes a helmet bag  
Head Restraint-ready

### COLORS

White, Gloss Black, +30 Matte Black, Blue, Red, Safety Orange, Silver and Pearl White



CODE: **663** SIZE: **7 1/8 - 7 3/4**

### RECOMMENDED FOR REPLACEMENT SHIELDS 101 SERIES

Dirt Track	CODE: 1010-17	COLOR: CLEAR
Off-Road	1011-17	SMOKE
Karting	1012-17	AMBER
Road Racing	1013-17	IRIDIUM
Stock Car	1014-17	MIRROR

*New 101 Series injection-molded shields provide exceptional clarity and no distortion.*

## SPEEDWAY RX

Classic "RX" styling with defined Wave Eliminators for reduced buffeting.

### FEATURES

Radio communications may be added  
Head Restraint-ready

### COLORS:

White, Gloss Black, +30 Matte Black, Blue, Red, Safety Orange, Silver and Pearl White



CODE: **651** SIZE: **7 1/8 - 7 3/4**

CODE: **653** TYPE: **DRAG RX WITH BUILT-IN DRAG SOCK (NOT SHOWN)**

### RECOMMENDED FOR REPLACEMENT SHIELDS 102 SERIES

Dirt Track	CODE: 1020-12	COLOR: CLEAR
Drag Racing	1021-12	SMOKE
Karting	1022-12	AMBER
Off-Road	1023-12	IRIDIUM
Road Racing	1024-12	MIRROR
Stock Car		

# RACING HELMETS

## DIAMONDBACK

The Diamondback features defined wave eliminators for reduced buffeting.

### FEATURES

Recessed eye port offers a 100% shield seal  
Head Restraint-ready  
Radio communications may be added  
Side pipe air option available

### COLORS:

White, Gloss Black, +30 Matte Black, Blue, Red, Safety Orange, Silver and Pearl White



CODE: **629**  
SIZE: **7 1/8 - 7 3/4**

### RECOMMENDED FOR REPLACEMENT SHIELDS 102 SERIES

RECOMMENDED FOR	CODE:	COLOR:
Circle Track	1020-12	CLEAR
Dirt Track	1021-12	SMOKE
Drag	1022-12	AMBER
Karting	1023-12	IRIDIUM
Off-Road	1024-12	MIRROR
Road Racing		

SIDE PIPE OPTION  
CODE: 97009



## SUPER BANDIT

Classic flagship Bandit design remains true to Simpson's heritage for distinct style and helmets you can trust to do their job.

### FEATURES

Snell SA 2015 rated  
Head Restraint-ready  
Radio communications may be added

### COLORS

White, Gloss Black, +30 Matte Black, Blue, Red, Safety Orange, Silver and Pearl White



CODE: **621**  
SIZE: **XS - XXL**

### RECOMMENDED FOR REPLACEMENT SHIELDS 89400 SERIES

RECOMMENDED FOR	CODE:	COLOR:
Circle Track	89400A	CLEAR
Dirt Track	89401A	SMOKE
Drag	89402	IRIDIUM
Karting	89403A	AMBER
Off-Road	89406A	MIRROR
Road Racing		

FORCED AIR TOP (NOT SHOWN)  
CODE: 97027CLR

FORCED AIR SIDE  
CODE: 97009



## BANDIT

Classic flagship Bandit design remains true to Simpson's heritage for distinct style and helmets you can trust to do their job.

### FEATURES

FIA 8859-2015 approved. Snell SA 2015 certified.  
Head Restraint-ready  
Radio communications may be added

### COLORS

White, Gloss Black, +30 Matte Black



CODE: **620**  
SIZE: **XS - XXL**

### RECOMMENDED FOR REPLACEMENT SHIELDS 89400 SERIES

RECOMMENDED FOR	CODE:	COLOR:
Circle Track	89400A	CLEAR
Dirt Track	89401A	SMOKE
Drag	89402	IRIDIUM
Karting	89403A	AMBER
Off-Road	89406A	MIRROR
Road Racing		



## DEVIL RAY COMPOSITE



Our popular Devil Ray Carbon helmet is now available in a composite version with the same outstanding customizable features as our Carbon Devil Ray. Composite weighs a little more than carbon but if you are looking for an incredible value, the composite Devil Ray is for you.

### FEATURES

Snell SA2015 certified  
 Required protection at a lower price  
 Devil Ray has the most add-on features, including  
 a peak for blocking the sun  
 High quality fit with removable cheek pads  
 Helmet includes a smaller set of cheek pads  
 to improve the fit of the helmet if needed  
 Head restraint ready

### COLORS

White, Gloss Black

CODE: **683** SIZE: **XS-XXL**

### RECOMMENDED FOR REPLACEMENT SHIELDS 89400 SERIES

RECOMMENDED FOR	CODE:	COLOR:
Circle Track	84300A	CLEAR
Dirt Track	84301A	SMOKE
Drag	84303	IRIDIUM
Karting	84304A	AMBER
Off-Road	84306A	MIRROR
Road Racing		

**FORCED AIR TOP**  
 CODE: 97034

**FORCED AIR SIDE**  
 CODE: 97009

**FORCED AIR TOP OFFSET**  
 RIGHT CODE: 97032  
 LEFT CODE: 97033

**DEVIL RAY PEAK**  
 CODE: PEAKDR

## VOYAGER 2

The Voyager 2 is a redesign for one of our customer favorites, featuring our largest eye port for excellent field of vision. The helmet interior included contrast stitching and branding.

### FEATURES

Snell SA 2015 approved  
 Head Restraint-ready  
 Radio communications may be added

### COLORS

White, Gloss Black, +30 Matte Black



CODE: **610** SIZE: **XS - XXL**

### RECOMMENDED FOR REPLACEMENT SHIELDS 88800 SERIES

RECOMMENDED FOR	CODE:	COLOR:
Circle Track	88800A	CLEAR
Dirt Track	88801A	SMOKE
Drag	88802A	AMBER
Karting	88803A	IRIDIUM
Off-Road	88804A	MIRROR
Road Racing		

**TOP AIR OPTION**  
 CODE: 97027



## VENATOR COMPOSITE

The composite Venator available in colors to complement your race car and racing suit. The Venator features a plush interior with gel ear cups and optional padded ear inserts.

### FEATURES

FIA 8859-2015 approved. Snell SA 2015 certified.  
 Plush interior with Simpson branding on cheeks  
 Gel ear cups  
 Optional padded ear inserts  
 Head Restraint-ready  
 Radio communications may be added  
 Top pipe and side pipe options available

### COLORS

White, Gloss Black, +30 Matte Black

**TOP AIR OPTION**  
 CODE: 97034



CODE: **685** SIZE: **XS - XXL**

### RECOMMENDED FOR REPLACEMENT SHIELDS 84500 SERIES

RECOMMENDED FOR	CODE:	COLOR:
Circle Track	84500	CLEAR
Dirt Track	84501	SMOKE
Drag	84502	AMBER
Karting	84503	IRIDIUM
Off-Road	84504	MIRROR
Road Racing		

**TOP AIR OPTION**  
 CODE: 97027

**SIDE AIR OPTION**  
 CODE: 97009

### Venator Chin Guard

CODE	FITS
97010	XS - M/L
97011	L - XXL





## DRAG BANDIT

### FEATURES

Head Restraint-ready  
Drag Sock is SFI.10 rated

### COLORS

White, Gloss Black, +30 Matte Black, Blue, Red, Safety Orange, Silver and Pearl White

CODE:  
**622**

SIZE:  
**XS-XXL**

**RECOMMENDED FOR**  
Drag Racing

### REPLACEMENT SHIELDS 89400 SERIES

CODE: 89400A 89401A 89402 89403A 89406A	COLOR: CLEAR SMOKE IRIDIUM AMBER MIRROR
--	--



## JUNIOR SPEEDWAY SHARK



The Jr. Speedway Shark is proportionately sized for younger racers.

### FEATURES

SFI 24.1 approved  
Head Restraint-ready  
Radio communications may be added

### COLORS

White, Gloss Black, +30 Matte Black, Blue, Red, Safety Orange, Silver and Pearl White

CODE:  
**178**

SIZE:  
**6 1/2 - 6 5/8**

**RECOMMENDED FOR**  
Circle Track  
Dirt Track  
Drag

### REPLACEMENT SHIELDS J8860 SERIES

CODE: J88600 J88601 J88602 J88603	COLOR: CLEAR SMOKE IRIDIUM AMBER
---	--

## FR CRUISER

Designed for racers who prefer an open face helmet.

### FEATURES

Snell SA 2015 approved  
Head Restraint-ready

### COLORS

White and Gloss black



CODE:  
**632**

SIZE:  
**XS - XXL**

**RECOMMENDED FOR**  
Circle Track  
Drag  
Off-Road  
Road Racing  
Car Club Enthusiasts

**REPLACEMENT VISOR**  
CODE:  
99502

## OTW SHORTY

The OTW Shorty is DOT Rated. Includes 4-way adjustable strap system and glare-reducing visor.

### COLORS

Black, White



CODE:  
**143**

SIZE:  
**XS - XL**

**RECOMMENDED FOR**  
Pit Crew Members



## PIT WARRIOR CREW

The Pit Warrior is worn by professional crews and off-road enthusiasts. Removable and washable interior. Wide field of vision, open face design, lightweight. Fourteen strategically placed vents offer excellent air flow. Factory-installed radio communications available.

### COLORS

Matte Black, White

CODE:  
145

SIZE:  
S - XXL

RECOMMENDED FOR  
Pit Crew Members

REPLACEMENT VISOR  
CODE:  
145VIS

## CUSTOM COLORS

Custom paint colors are available by special order on all Simpson helmets manufactured at our New Braunfels, Texas, facility.

Available for Speedway Shark, Air Inforcer Shark, Air Inforcer Vudo, Vudo EV1, Speedway RX, Diamondback, Super Bandit, Drag Bandit, and Jr. Speedway Shark models.

### Custom Colors

Shown on the Diamondback



\* Fluorescent paint has limited UV Protection

## MEMORABILIA AUTOGRAPH HELMET

A blank signature helmet for your favorite autographs.

### COLORS

White, Black and Matte Black



For display only. Do not wear for racing.

CODE:  
2130001  
2130002  
2130008

COLOR:  
WHITE  
BLACK  
MATTE BLACK

## MEASURING FOR A HELMET

A correctly fitted helmet should feel like an even amount of pressure is being exerted around your head and cheeks. But helmets break in, so it should fit as tight as you can comfortably wear it. Once fastened, you should NOT be able to pull it off your head in any direction. Attention first-time helmet buyers: If your helmet is loose at all, and doesn't fit well, it CANNOT deliver the best protection. A helmet's strict safety standards can be compromised after only one impact collision. If the integrity is in question, send it back to us for proper inspection.

### MEASURE DIRECTLY ABOVE THE BROW LINE FOR THE BEST HELMET FIT.

Simpson Recommends Inspection Of Your Helmet After Any Impact Collision.

ADULT HELMET SIZE CHART															
INCHES	20	21	22	23	24	25									
CENTIMETERS	51	52	53	54	55	56	57	58	59	60	61	62	63	64	65
HAT SIZE	6 5/8 - 6 3/4		6 3/4 - 7		7 1/8 - 7 1/4		7 1/4 - 7 1/2		7 1/2 - 7 3/4		7 3/4 - 8				
HELMET SIZE	XS		SM		MD		LG		XL		XXL				

FIA HELMET SIZE CHART												
INCHES	20	21	22	23	24							
CENTIMETERS	51	52	53	54	55	56	57	58	59	60	61	62
HELMET SIZE	XS		SM		MD		LG		XL			

YOUTH HELMET SIZE CHART				
INCHES	20	21		
CENTIMETERS	51	52	53	54
HELMET SIZE	YOUTH M	YOUTH L	ADULT JR	

## NEW ACRYSOL SHIELD CLEANER

Acrysol shield cleaner is recommended by Stilo for helmet shield care. Acrysol is also compatible with Simpson helmet shields.



CODE:  
YA0640

## DUAL SHIELD BAG



CODE:  
23900

## REPLACEMENT SHIELDS

To order Replacement Shields for a Snell 2005 Helmet, call 800-654-7223.  
Snell 2005 rated helmet shields do not fit Snell 2010 helmets for some models.

### 101 SERIES - FITS SHARK AND VUDO MODELS

CODE:	COLOR:
1010-17	CLEAR
1011-17	SMOKE
1012-17	AMBER
1013-17	IRIDIUM
1014-17	MIRROR

*New 101 Series injection molded shields provide exceptional clarity and no distortion.*

### 102 SERIES - FITS X BANDIT, DIAMONDBACK, SKULL AND RX MODELS

CODE:	COLOR:
1020-12	CLEAR
1021-12	SMOKE
1022-12	AMBER
1023-12	IRIDIUM
1024-12	MIRROR

### 103 SERIES - FITS SA10 SW VOYAGER, VOYAGER EVOLUTION AND BULL DOG

CODE:	COLOR:
1030-12	CLEAR
1031-12	SMOKE
1032-12	AMBER
1033-12	IRIDIUM
1034-12	MIRROR

### ADDITIONAL

#### SNELL 2010 AND 2015 HELMET SHIELDS

Clear and Smoke prices listed.

CODE:	FITS:
84300 SERIES	DEVIL RAY
89400 SERIES	BANDIT, SUPER BANDIT, CARBON BANDIT, DRAG BANDIT, CH3N02
89100 SERIES	OUTLAW BANDIT
88200A SERIES	VOYAGER, MODEL 410
89900 SERIES	K10, KART HELMET
86030 SERIES	STREET BANDIT
84500 SERIES	VENATOR
88800 SERIES	VOYAGER 2

## PIVOT KITS

### DETENT PIVOT KITS

Hardware included.	CODE:	FITS:
	99014	101, 102, 103 SERIES AND VOYAGER 2 SHIELDS
	99013	DEVIL RAY
	99016	BANDIT/CARBON BANDIT
	99022	VOYAGER MODEL 410
	99002	SUPER BANDIT
	99018	VENATOR



## RACING OPTICS TEAROFFS

2mm laminated tearoffs. 3 Speedstacks™ of 10 tearoffs.



### Laminated tearoffs

CODE	FITS
10201C	VOYAGER HELMET MODEL 410
10203C	JR. SPEEDWAY SHARK
10204C	RX, SUPER BANDIT, BANDIT, X BANDIT, DIAMONDBACK
10209C	SUPER SHARK, VUDO, AIR INFORCER SHARK, DEVIL RAY, VOYAGER EVOLUTION, SIDEWINDER VOYAGER, VOYAGER 2, SNELL SA 2015 MODELS
10210C	VENATOR
98022	GOLD ALUMINUM TEAROFF POSTS. FITS: ALL MODELS

## RADIO COMMUNICATION



Simpson is proud to offer Rugged Radio's exclusive communication technology for Racing Radio Driver and Crew Communication systems. Order your favorite Simpson helmet complete with factory-installed communications equipment. Save time, save on shipping charges. Helmet kit pricing as shown includes installation. Simpson helmets are fully certified to be Snell and/or FIA compliant when equipped with Rugged Radios helmet kit installations. PCI Radios also available for off-road applications. Call us at 800-654-7223.

### OFF-ROAD HELMET KIT

Kit Includes Flex Boom, Helmet Speakers and 3.5 mm Ear Bud Jack



This complete off-road flex boom helmet kit features Rugged Radios' new Dura-Link Sealed Connector, Clear Hear speakers and dynamic noise canceling mic for best audio performance, and 3.5mm input port for music cable or ear buds. The Dura-Link Seal, featured on all Rugged helmet kits, seals the connection between the intercom cable and helmet kit plug. The Dura-Link Seal protects the connection contacts from water, mud and dirt which can affect audio performance and works with current Rugged off-road intercom cables.

CODE	TYPE
<b>96044</b>	<b>OFF-ROAD HELMET KIT</b>

### EAR CUPS



CODE	TYPE
<b>96002</b>	<b>EAR CUPS W/SPEAKERS &amp; INSTALLED (ONE WAY RADIO)</b>
<b>96001</b>	<b>EAR CUPS INSTALLED, W/O SPEAKERS</b>
<b>96000</b>	<b>EAR CUPS, W/O INSTALLATION AND SPEAKERS</b>

### NASCAR HELMET KIT

The National Association for Stock Car Auto Racing



CODE	TYPE
<b>96023</b>	<b>NASCAR HELMET KIT (3 COND) W/FLEX BOOM &amp; COIL WITH EAR CUP SPEAKERS</b>
<b>96033</b>	<b>WITH EAR CUP SPEAKERS</b>

### NASCAR HELMET KIT

The National Association for Stock Car Auto Racing



CODE	TYPE
<b>96003</b>	<b>NASCAR HELMET KIT (3 COND) W/FLEX BOOM &amp; STRAIGHT CORD WITH EAR CUP SPEAKERS</b>
<b>96013</b>	<b>WITH EAR CUP SPEAKERS</b>

### IMSA HELMET KIT

The International Motor Sports Association



CODE	TYPE
<b>96024</b>	<b>IMSA HELMET KIT (4 COND) W/FLEX BOOM &amp; COIL CORD WITH EAR CUP SPEAKERS</b>
<b>96034</b>	<b>WITH EAR CUP SPEAKERS</b>

### IMSA HELMET KIT

The International Motor Sports Association



CODE	TYPE
<b>96004</b>	<b>IMSA HELMET KIT (4 COND) W/FLEX BOOM &amp; STRAIGHT CORD WITH EAR CUP SPEAKERS</b>
<b>96014</b>	<b>WITH EAR CUP SPEAKERS</b>



## HELMET EJECT AND EMS



Simpson's Eject Helmet Removal System is a small air bladder that fits easily into any helmet, without changing its fit or feel. In the event of a crash, First Responders can help reduce the risk of secondary neck or spine injuries by inflating the Eject System which gently lifts the helmet off the head.



### EJECT EMT AMBULANCE/TRACK KIT

Complete Eject Kit for track or ambulance contains:

- 3 EMT Helmet Bladders
- 1 Bulb Inflator
- 1 CO2 Inflator
- 4 CO2 Cartridges (16 grams each)
- 1 Track Bag



CODE  
**898-01-KIT**

### EJECT CO2 CARTRIDGE

Carbon Dioxide cartridge for Eject CO2 Inflator



CODE  
**896-01-30-B**

### EJECT EMT BLADDER

Air bladder with attached hose for helmet installation.



CODE  
**892-01-BLR**

### EJECT BULB INFLATOR

Eject Inflator powered by a small rubber bulb



CODE  
**897-01-30**

### EJECT CO2 INFLATOR

Eject Inflator powered by a small Carbon Dioxide cartridge. Includes one cartridge. Additional cartridges sold separately.



CODE  
**895-01-30**

### EJECT BLADDER

Eject and installation.



CODE  
**890-01-30**  
**890-01-30I**

TYPE  
**EJECT BLADDER**  
**EJECT BLADDER W/ INSTALL**

# RACING HELMETS

## BUILT IN HELMET SKIRTS



### Helmet Skirts

CODE	FITS
97008	SFI 3.3/5 CarbonX®
97028	SFI 3.3/10 CarbonX®
97038	SFI 3.3/5 CarbonX® CONTOURED HELMET SKIRT
97048	SFI 3.3/10 CarbonX® CONTOURED HELMET SKIRT



F/C AIR SYSTEM

DRAG SOCK

## THE F/C AIR SYSTEMS



Can be installed on most Simpson fullface helmets. Advanced internal airflow system distributes fresh air throughout, with venting to the mouth/nose, and 2 clearing ports on each side to eliminate fogging. Drag sock and Kevlar® gasket purchased separately. Requires use of drag sock.

### Drag Air System

CODE:  
**97025**

### Drag Sock

SFI 3.3/10 CarbonX®, built in drag sock

CODE:  
**97003**

## THE F/C EXTERNAL AIR SYSTEM

The F/C Air System was designed in 1998 to provide constant flow or on-demand air to the driver in the event of a fire. Composite bottle will hold 5 to 10 minutes of air, depending on flow setting. System includes Flow Control Regulator, ball valve, 8 ft. fire rated hose, hose fittings and 3000 PSI rated bottle (114 cubic inches) and shut-off valve assembly.



### Air System

CODE:  
**FCC**



## BREATH DEFLECTOR

Helps seal mouth and nose area and keeps fresh air in and unwanted fumes out. Can be molded to conform to contours of nose. Prevents fogging and can be used in conjunction with Sidewinder F.A.S. Must have helmet to install at factory.

Adjustable Breath Deflector (Shown)  
Breath Deflector

CODE:  
**97035**  
**97022**

## CHIN FLAP (NOT SHOWN)

Helps seal area under chin to prevent air flow that can cause lift. Prevents dust and debris from entering helmet. Reduces noise while improving microphone pickup. Must have helmet to install at factory.

### Chin Flap

CODE:  
**97015**

**STILO HELMETS**

**TAKES WEIGHT OFF  
YOUR HEAD  
AND SHOULDERS**

# STILO RACING HELMETS

## STILO RACING HELMETS

Simpson Performance Products will proudly become the exclusive USA importer and seller for Stilo helmets beginning January 1, 2018. Stilo is the industry's leading manufacturer and designer of helmets and helmet communication systems for global motorsports. Stilo helmets are manufactured at the Stilo headquarters in Pedrengo, Italy.



ST5 FN  
**ZERO 8860**

**Stilo**

*Any competition one helmet*



ST5 GT **COMPOSITE**



ST5 GT  
**CARBON**

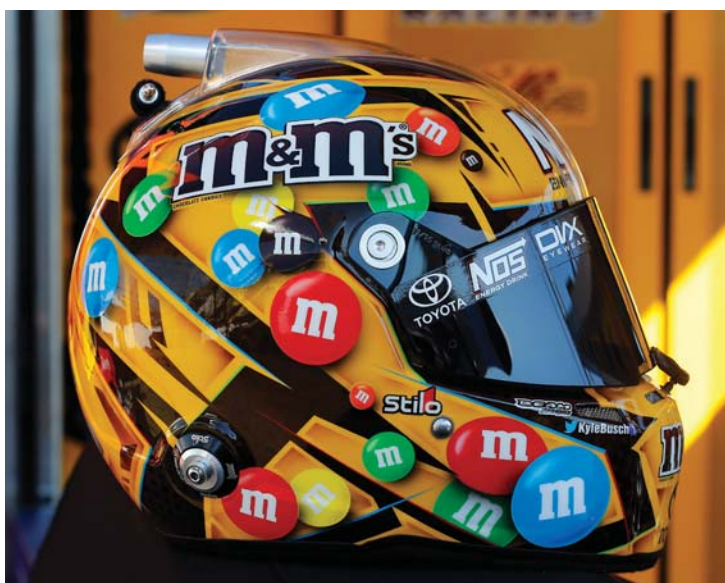

STILO ST5 FN ZERO 8860 WITH TOP AIR AS WORN BY KYLE BUSCH IN THE NASCAR MONSTER ENERGY SERIES

**STILO RALLY HELMETS**



**WRC DES ZERO 8860**



**WRC DES CARBON PIUMA**



**TROPHY DES PLUS**



**ST5R RALLY FULL FACE**

A person wearing a black motorcycle helmet and a black leather jacket is performing a wheelie on a blue and silver motorcycle. The motorcycle is balanced on its rear wheel, with the front wheel high in the air. The background shows a parking lot with several large, colorful shipping containers (red, yellow, and blue) and a yellow piece of machinery. The scene is lit with warm, golden light, suggesting late afternoon or early morning. The overall mood is one of rebellion and adventure.

**MOTORCYCLE HELMETS**

**THROW  
GOOD MONEY AFTER  
BADASS**

## GHOST BANDIT



Designed 100% with motorcycle riders in mind, the Simpson Ghost Bandit is prepared to handle just about any type of riding in killer style and complete comfort. The lightweight shell has been aerodynamically tuned for motorcycle riding, and is fully ventilated for maximum airflow when, and where, you need it most. Integrated speakers and microphone pockets make it easy to install your favorite communication device, and a drop-down sun visor makes riding through changing light conditions a breeze.

### FEATURES

- Lightweight Composite and Carbon Fiber versions
- DOT/ECE Certified
- Removable liner
- Internal sun visor
- Multiple shield options
- Integrated speaker and boom mic pockets
- Dual adjustable chin vents
- Top and rear ventilation
- Removable chin air dam

### COLORS

White, Black, Flat Black, +200 Carbon



CARBON

Tri Composite

CODE: **GB** SIZE: **XS - XXL**

Carbon Fiber

CODE: **GB** SIZE: **XS - XXL**

### RECOMMENDED FOR REPLACEMENT SHIELDS GB SERIES

Motorcycles	EXTERIOR SHIELDS	COLOR:
	CODE:	CLEAR
	GBCSE	LIGHT SMOKE
	GBLSE	SMOKE
	GBDSE	AMBER
	GBASE	IRIDIUM
	GBISE	MIRROR
	GBMSE	
	INTERIOR SHIELDS	
	CODE:	CLEAR
	GBCSI	LIGHT SMOKE
	GBLSSi	SMOKE
	GBDSSi	AMBER
	GBASI	

ADDITIONAL COLORS  
GLOSS BLACK



WHITE



FLAT BLACK



## STREET BANDIT



The Street Bandit Motorcycle Helmet is one of our best-selling helmets.

### FEATURES

- DOT and Snell M2015
- Classic Bandit look for the motorcycle rider
- The Street Bandit features an enlarged eye port area for excellent field of vision
- Chin air ram duct vents
- Top vents with shutoff option

### COLORS

White, Gloss Black and Flat Black



FLAT BLACK

CODE: **MSB** SIZE: **XS - XXL**

### RECOMMENDED FOR REPLACEMENT SHIELDS 86030 SERIES

Motorcycles	CODE:	COLOR:
	86030M	CLEAR
	86031M	DARK SMOKE
	86032M	AMBER
	86033M	IRIDIUM
	86034M	MIRROR

Replacement Pivot Kits

CODE: **99017**

ADDITIONAL COLORS  
WHITE



GLOSS BLACK



Motorcycle Helmets shown with optional Dark Smoke shield



NEW GUNMETAL

## OUTLAW BANDIT

### FEATURES

Chin air ram duct for improved air circulation, reduced lift counter measures  
DOT and Snell M2015

### COLORS

White, Gloss Black, Flat Black and Gunmetal

CODE: **283** SIZE: **XS - XXL**

### RECOMMENDED FOR REPLACEMENT SHIELDS 89200 SERIES

Motorcycles	<i>Need to know size of helmet</i>	
	CODE:	COLOR:
	89200M	CLEAR
	89201M	SMOKE
	89202M	AMBER
	89203M	IRIDIUM
	89204M	SILVER
	89206M	GOLD MIRRORRED

Replacement Pivot Kits

CODE: **99011**

## M50

The M50 Moto from the 70s is reborn in a sleek helmet with a nod to vintage, backed by over 50 years of Simpson technology. DOT Rated. The M50 features a five-snap visor. See photo.

Additional cheek pads available

### COLORS

White, Gloss Black and Flat Black, Flat Gunmetal, Red and Yellow



GLOSS BLACK

CODE: **M50** SIZE: **XS - XL**

### RECOMMENDED FOR ADDITIONAL VISOR

Motorcycles CODE: **M50VISOR**

ADDITIONAL COLORS  
WHITE



RED



YELLOW



FLAT GUNMETAL



## M30

Classic Simpson M30 styling.

### FEATURES

Cool Max<sup>®</sup> lined fabric moves moisture away from your body, keeping you cool and comfortable

DOT Rated

"Free Stop" pivot system allows the wearer to stop the shield at any angle

Additional cheek pads available  
Approximate weight of Carbon versions – 2.5 pounds

Approximate weight of non-Carbon versions – 3.0 pounds

### COLORS

White, Gloss Black, Flat Black and Gloss Carbon



Fiberglass

CODE: **M30** SIZE: **XS - XL**

Carbon Fiber

CODE: **M30** SIZE: **CARBON: XS - XL**

### RECOMMENDED FOR REPLACEMENT SHIELDS M30 SERIES

Motorcycles	CODE:	COLOR:
	M30CS	CLEAR
	M30LSS	LIGHT SMOKE
	M30DSS	DARK SMOKE
	M30LRS	LIGHT IRIDIUM
	M30LCS	LIGHT CHROME

Replacement Pivot Kits

CODE: **M30PK**





**HEAD RESTRAINTS**

**NOW ALL YOU HAVE  
TO FEAR IS  
LOSING**

SIMPSON  
**Hybrid**  
PRO

**NASCAR**



er

## HEAD RESTRAINTS



### WHAT YOU NEED TO KNOW

#### Why do I need a frontal head restraint system?

Quite simply, head restraints save racers' lives!

If you are unfortunate enough to be involved in an accident during a race and you are wearing a head restraint system, then your seatbelt is likely going to do its job and stop your body from moving forward. The head restraint will do its job and stop your head from whipping forward and placing enormous strain on your neck. A racer's head is made heavier than normal by the added weight of a helmet. Frontal impact in a race car can cause basilar skull fractures which are often fatal and have taken the lives of some of history's greatest racers. Keep in mind that it isn't necessarily how fast you are going but how fast you stop that causes some of the worst injuries.

#### How do they work?

Both HANS and Hybrid head restraint devices work by using shoulder harness friction to resist forward head movement and ensure proper rotation during rapid forward deceleration.

#### Do I need to use a specific seatbelt harness?

No, but the configuration of the seatbelt harness is critical and some head restraints are tailored for use with a FHR-specific seatbelt harness.

The shoulder strap mounting points should be even with the shoulders such that the straps make an angle of 10° to the horizontal.

The mounting points must be equally disposed about the user's centreline so that straps spread inward slightly from the mountings and around the FHRs.

This helps to keep the straps firmly engaged with the FHRs.

#### Which device is right for me?

The HANS is a yoke-style device and the Hybrids use straps, much like a backpack design.

In short, you should choose the device that is most comfortable to you.

Every head restraint device sold by Simpson is certified and approved by either the FIA, SFI or NASCAR.

Some devices hold multicertifications.



### Restraint System Mounting Zones (Side View)

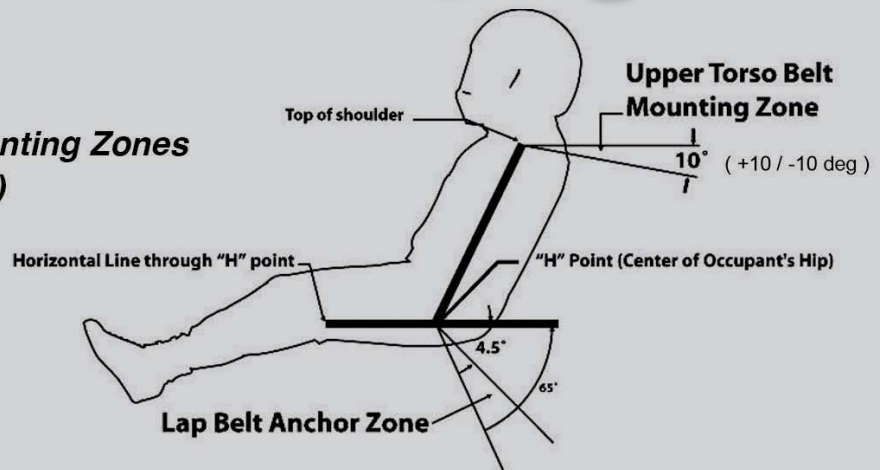

## HYBRID PRO LITE

The Hybrid Pro Lite® is the ultimate in safety and comfort. The Hybrid Pro Lite's new lightweight design and carbon fiber construction provides maximum comfort and maneuverability with superior strength. All of Simpson's Hybrid Series head restraints are designed for easily exiting the car without the danger of being entangled in other gear by offering the lowest profile of any comparable device. This device comes with optional patented SAS (Seatbelt Anchor System) for even greater coverage in flips, barrel rolls and side impacts. When the worst happens, you'll have the same great protection every time.



CODE: HYPL      SIZE: XS-XL

CODE: HYPL      SIZE: XS-XL W/ SAS

### FEATURES

Ships race ready with Quick release and D-ring Helmet Anchors

### UPGRADES

- Post Anchors/ Tether Kit
- M61 Quick Release/Dual End Tether Kit
- Seatbelt Anchor System
- Quick Click Anchors/Tether Kit

SHOWN WITH  
M6 ANCHOR OPTION

## HYBRID PRO X PACKAGE

### NHRA TOP FUEL AND FUNNY CAR

The Hybrid X package is designed for drag racing's extreme speeds and includes the Hybrid Pro Head Restraint with SAS, specially fitted with the double chin strap "W" style and a semi-rigid neck collar constructed of SFI 45.2 approved padding. The X package provides extreme protection and support and features six tethers connecting to 4 points on the helmet. The Hybrid Pro with X package is worn by top NHRA racers, including John Force and Robert Hight. Includes a Hybrid Pro, double chin strap and semi-rigid neck collar.



CODE: HR.X.PKG      SIZE: XS-XL, CUSTOM AVAILABLE

### UPGRADE

Quick Click Anchors/Tether Kit



SEMI-RIGID NECK COLLAR

DOUBLE CHIN STRAP

# HEAD RESTRAINTS

## HYBRID SPORT

The Hybrid Sport® is a great head restraint device for those racing on a budget. The Hybrid Sport with its new lightweight design and DuPont® carbon/polymer construction provides maximum comfort and maneuverability with superior strength. All of Simpson's Hybrid Series head restraints are designed for easily exiting the car without the danger of being entangled in other gear by offering the lowest profile of any comparable device. This device comes with optional patented SAS (Seatbelt Anchor System) for even greater coverage in flips, barrel rolls and side impacts. When the worst happens, you'll have the same great protection every time.



CODE: **HS**      SIZE: **XS-XL**

CODE: **HS**      SIZE: **XS-XL W/ SAS**

### FEATURES

Ships race ready with Quick release and D-ring Helmet Anchors

### UPGRADES

Post Anchors/Tether Kit  
M61 Quick Release/Dual End Tether Kit  
Seatbelt Anchor System  
Quick Click Anchors/Tether Kit

SHOWN WITH  
M6 ANCHOR OPTION

## HYBRID SPORT YOUTH

The Hybrid Sport® Jr. sizes give you all the safety as an Adult version, but 25% smaller to fit a Youth as young as 4 years. The Hybrid Sport with its lightweight design and DuPont® carbon/polymer construction provides maximum comfort and maneuverability with superior strength. All of Simpson's Hybrid Series head restraints are designed for easily exiting the car without the danger of being entangled in other gear by offering the lowest profile of any comparable device. This device comes with optional patented SAS (Seatbelt Anchor System) for even greater coverage in flips, barrel rolls and side impacts. When the worst happens, you'll have the same great protection every time.



### Hybrid Sport Youth

CODE	FITS		
HS.XSC	XS/CHILD	22-26"	4-6 YEARS
HS.CHD	CHILD	22-26"	7-9 YEARS
HS.YTH	YOUTH	26-30"	9-12 YEARS

Age ranges are meant as a guide; if in doubt call 1-800-654-7223 for assistance.

### FEATURES

Ships race ready with Quick release and D-ring Helmet Anchors.  
Hybrid Sport Jr. Sizes come with Fixed-length back tethers:  
XSC: 10" | CHD: 11" | Youth: 12"

### UPGRADES

Post Anchors/ Tether Kit  
M61 Quick Release/Dual End Tether Kit  
Seatbelt Anchor System  
Quick Click Anchors/Tether Kit



Simpson's Hybrid S model is currently the only Frontal Head Restraint proven effective for 3-point harnesses, and the device is also FIA and SFI approved. Additionally, in a partnership with Detroit auto manufacturers, the Hybrid S is third party tested to FMVSS208.

The Hybrid S allows high-performance driving Instructors, auto manufacturing test engineers, and other drivers with 3-point harnesses access to the advantages of head restraint safety.

The FIA Hybrid Head Restraint, in conjunction with a Snell or FIA rated helmet and a 3-point harness, reduced neck tension significantly when compared to a test with only a helmet and 3-point harness.

While we can offer head restraint protection for use with 3-point seatbelts, Simpson's top concern is driver and instructor safety. We suggest a Full Containment Cockpit System that includes a Full Containment Seat, Snell or FIA rated Helmet, FIA or SFI approved Frontal Head Restraint, and a 5 to 7-point seatbelt harness system for the best protection while on the track.

### FEATURES

- FIA approved, SFI certified
- High-quality carbon fiber construction
- Low profile. No high back to hook on the bars on exit.
- Multiple load paths to dissipate head loads
- Buckle attachment in front. No bulky straps underneath.
- Ships race ready with post clips
- Seat belt anchor system
- Helmet anchors available for upgrade

Hybrid S	
CODE HYS.PA	FITS POST ANCHORS, ALL SIZES, W/O HELMET ANCHORS
HYS.M61	M61 UPGRADE OPTION, ALL SIZES, WITH HELMET ANCHORS



3 Point OEM  
Harness Compatible

**PROTECTION STATEMENT** *Simpson's top concern is your safety. For your BEST protection on the racetrack, we suggest a full containment cockpit system that includes a full containment seat, Snell rated helmet, SFI or FIA approved head restraint and 7-point belt system.*

# HEAD RESTRAINTS

## OPTIONAL HELMET ACCESSORIES AND TETHERS FOR SIMPSON HYBRID

### M61 DUAL END FITTING TETHER-PAIR

Used with M6 Anchor System.

CODE:  
HS.M61.DE



### HYBRID POST CLIPS-PAIR

CODE:  
HS.PA  
HY.PA



### QUICK RELEASE ASSEMBLY

Used with D rings.

CODE:  
HS.QR (1 SIDE)  
HY.QR (1 SIDE)



### HY QUICK CLICK LOOP

CODE:  
HS.QC  
HY.QC



### ADJUSTABLE SLIDING TETHER

Used with Simpson Head Restraints.

CODE:  
HR.STK.L



## OPTIONAL HELMET ANCHOR

### M6 ANCHOR

CODE:  
M61.HAK  
M61.HAK.SAH W/O WASHERS



### SIMPSON POST ANCHORS PAIR

CODE:  
PA.HAK  
PA.HAK.SAH W/O WASHERS



### D-RINGS

CODE:  
SF1.DRK  
SF1.DRK.SAH



### SIMPSON QUICK CLICK SYSTEM

CODE:  
QC.HAK  
QC.HAK.SAH W/O WASHERS



## HYBRID SIZING CHART

### CHEST STRAP WITH DRIVING SUIT ON

#### HOW TO MEASURE

1. Measure around chest below pectoral muscles.
2. Measure with driving suit. If not available add 1" to measurement.
3. Take measurement with tape placed against driver without any slack and without pulling the tape tight.
4. Once measurement has been determined, refer to size charts to device size selection.

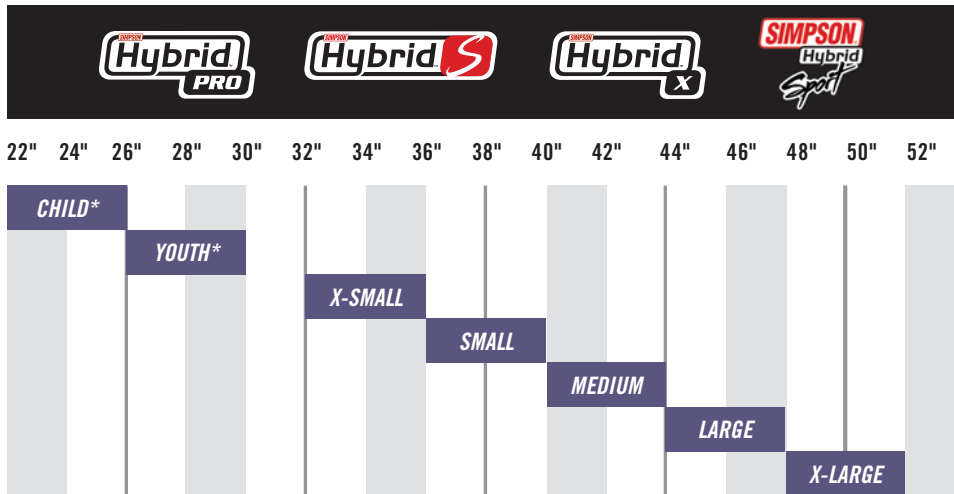

\*CHILD AND YOUTH SIZES AVAILABLE IN HYBRID SPORT.

## HANS DEVICE SIZING CHART

Neck size is the starting point for fitting a HANS Device.  
You may fit several sizes – comfort is the deciding factor. See HANS selection, beginning page 32.

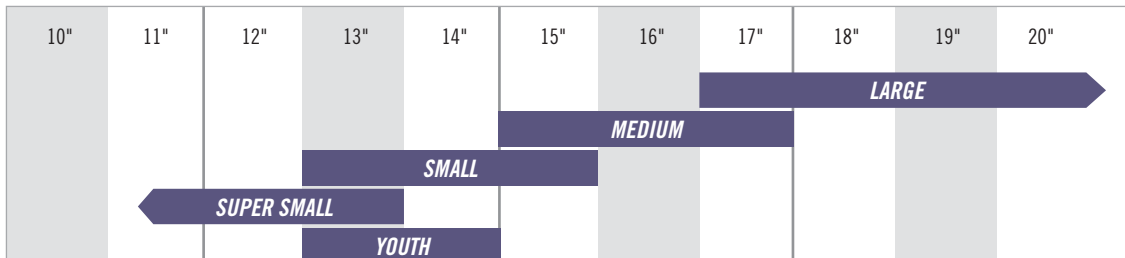

# HEAD RESTRAINTS



## HANS III

The HANS III represents the third generation of injection molded HANS devices and takes a revolutionary approach to reducing weight. Using an all-new design and polymer, the HANS III features a hollow collar to substantially minimize weight. Engineered reinforcements ensure this HANS offers the same level of safety as every HANS device, while the reduced mass guarantees the lightest, most comfortable injection molded HANS ever. Call for FIA pricing.



### Hans III

CODE	SIZE
DK 14237.311 SFI	20 MEDIUM, PA SLIDING SAH, SFI
DK 14237.321 SFI	20 MEDIUM, PA SLIDING, SFI
DK 14237.411 SFI	20 MEDIUM, QUICK CLICK, SAH, SFI
DK 14237.421 SFI	20 MEDIUM, QUICK CLICK, SLIDING, SFI
DK 14247.311 SFI	20 LARGE, PA SLIDING SAH, SFI
DK 14247.321 SFI	20 LARGE, PA SLIDING, SFI
DK 14247.411 SFI	20 LARGE, QUICK CLICK, SAH, SFI
DK 14247.421 SFI	20 LARGE, QUICK CLICK, SLIDING, SFI

## YOUTH HANS III

The lightweight HANS III is now available in a Youth size. The SFI 38.1 certified HANS III Youth features a hollow collar that substantially minimizes weight and is engineered for the growing young racer. Reinforcements ensure an exceptionally strong structure that provides the same level of safety as every HANS device.

See sizing chart for recommendations – remember driver comfort is the most important factor when choosing a size.



### Youth Hans III

CODE	SIZE
DK 16217.311 SFI	20, PA SLIDING FOR SAH, SFI
DK 16217.321 SFI	20, PA SLIDING FOR SA, SFI
DK 16217.411 SFI	20, QC SLIDING FOR SAH, SFI
DK 16217.421 SFI	20, QC SLIDING FOR SA, SFI

## HANS PRO ULTRA LITE

The HANS Pro Ultra Lite is SFI 38.1 and FIA approved. The Pro Ultra device applies aerospace grade carbon to achieve a 100+ gram weight saving compared to the regular Ultra. The Ultra Lite saves on weight and allows for easy entry and exit from the race car, even smaller, tighter vehicles. The 100% carbon fiber construction features a hollow core for increased weight reduction without sacrificing strength. The sliding tethers offer exceptional visibility. Call for FIA pricing. Upgrade to the Pro Ultra Lite today.



### HANS Pro Ultra Lite

CODE	SIZE
DK 14236.31 SFI	20M, PA SLIDING FOR SAH HELMET, SFI
DK 14236.32 SFI	20M, PA SLIDING FOR SA HELMET, SFI
DK 14236.41 SFI	20M, QC SLIDING FOR SAH HELMET, SFI
DK 14236.42 SFI	20M, QC SLIDING FOR SA HELMET, SFI
DK 14246.31 SFI	20L, PA SLIDING FOR SAH HELMET, SFI
DK 14246.32 SFI	20L, PA SLIDING FOR SA HELMET, SFI
DK 14246.41 SFI	20L, QC SLIDING FOR SAH HELMET, SFI
DK 14246.42 SFI	20L, QC SLIDING FOR SA HELMET, SFI

### FOR LAYDOWN CARS

DK 16336.31 SFI	30M, PA SLIDING FOR SAH HELMET, SFI
DK 16336.32 SFI	30M, PA SLIDING FOR SA HELMET, SFI
DK 16336.41 SFI	30M, QC SLIDING FOR SAH HELMET, SFI
DK 16336.42 SFI	30M, QC SLIDING FOR SA HELMET, SFI





## HANS PRO ULTRA

### NASCAR APPROVED

The HANS Pro Ultra is SFI 38.1 and NASCAR approved. The Pro Ultra device applies lightweight construction of the Carbon Fiber Pro series to the modern new shape of the Sport II. The Ultra saves on weight and allows for easy entry and exit from the race car, even smaller, tighter vehicles. The 100% carbon fiber construction features a hollow core for increased weight reduction without sacrificing strength. The sliding tethers offer exceptional visibility. Upgrade to the Pro Ultra today.



#### Hans III

CODE	SIZE
DK 13235.31 SFI	20M PRO ULTRA, PA SLIDING FOR SAH HELMET, SFI
DK 13235.32 SFI	20M PRO ULTRA, PA SLIDING FOR SA HELMET, SFI
DK 13235.41 SFI	20M PRO ULTRA, QC SLIDING FOR SAH HELMET, SFI
DK 13235.42 SFI	20M PRO ULTRA, QC SLIDING FOR SA HELMET, SFI
DK 13245.31 SFI	20L PRO ULTRA, PA SLIDING FOR SAH HELMET, SFI
DK 13245.32 SFI	20L PRO ULTRA, PA SLIDING FOR SA HELMET, SFI
DK 13245.41 SFI	20L PRO ULTRA, QC SLIDING FOR SAH HELMET, SFI
DK 13245.42 SFI	20L PRO ULTRA, QC SLIDING FOR SA HELMET, SFI

## HANS PROFESSIONAL SERIES NASCAR APPROVED

Professional HANS devices are lightweight handlaid carbon fiber. The HANS Professional device is worn by professional racers worldwide, including NASCAR's finest racers like Jimmie Johnson, Tony Stewart and Denny Hamlin. Call for FIA pricing.

### FEATURES

**The Model 20**, our most popular angle, fits upright seats like those found in most sports cars, from Honda to Lamborghini. Fits most stock cars, drag cars, sprints, modifieds and similar. Available in 4 sizes – Super Small (youth), Small, Medium, Large.

**The Model 10** fits extreme upright seats like those found in sprint cars. It also is comfortable for some very thin drivers. Model 10 available in size Medium only.

**The Model 30** fits laydown seats like some Formula cars. It also is comfortable for larger drivers in sports cars in place of a Model 20. Available in size Large only.

**The Model 40** – special order for vintage single seaters only. Available in size Medium only.



#### Hans III

CODE	SIZE
DK 11211.321 SFI	SUPER SMALL 20 PRO, PA SLIDING
DK 11211.421 SFI	SUPER SMALL 20 PRO, QUICK CLICK SLIDING
DK 11221.321 SFI	SMALL 20 PRO, PA, SLIDING
DK 11221.421 SFI	SMALL 20 PRO, QUICK CLICK, SLIDING
DK 11131.321 SFI	MEDIUM 10 PRO, PA, SLIDING
DK 11131.421 SFI	MEDIUM 10 PRO, QUICK CLICK SLIDING
DK 11231.321 SFI	MEDIUM 20 PRO, PA, SLIDING
DK 11231.421 SFI	MEDIUM 20 PRO, QUICK CLICK
DK 11431.321 SFI	MEDIUM 40 PRO
DK 11241.321 SFI	LARGE 20 PRO, PA, SLIDING
DK 11241.421 SFI	LARGE 20 PRO, QUICK CLICK, SLIDING
DK 11341.321 SFI	LARGE 30 PRO, PA, SLIDING
DK 11341.421 SFI	LARGE 30 PRO, QUICK CLICK, SLIDING

## HANS ADJUSTABLE SERIES



This head and neck restraint from HANS promises to be a great addition to the head restraint market with an adjustable feature for those racers who want a customized comfort level. Call for FIA pricing.

### FEATURES

Device adjusts in 5 degree increments, from 10 to 40 degrees  
Available in 2 collar sizes, Medium or Large  
Fits all types of race cars and seats  
Ships with complete instructions plus tools to adjust device



#### Hans III

CODE	SIZE
DK 13034.32 SFI	MEDIUM ADJUSTABLE DEVICE WITH SLIDING TETHERS & PROF. POST ANCHORS
DK 13034.42 SFI	MEDIUM ADJUSTABLE DEVICE WITH SLIDING TETHERS & QUICK CLICK ANCHORS
DK 13044.32 SFI	LARGE ADJUSTABLE DEVICE WITH SLIDING TETHERS & PROF. POST ANCHORS
DK 13044.42 SFI	LARGE ADJUSTABLE DEVICE WITH SLIDING TETHERS & QUICK CLICK ANCHORS

# HEAD RESTRAINTS

## HANS ACCESSORIES

### POST COLLAR ANCHOR



Professional Series

CODE	TYPE
A. AK1131.12	SAH HELMET
B. AK1132.12	SA HELMET

Professional Anchors are offered in Black, Blue, Red, Silver

### M61 SINGLE END FITTING TETHER-PAIR

Used with M6 Anchor System

CODE	Type
TK1451.3	SPORT II
TK1451	SPORT I, PROFESSIONAL
TK1451.4	ADJUSTABLE, PRO ULTRA
TK1451.7	HANS III



### QUICK CLICK ATTACHMENT

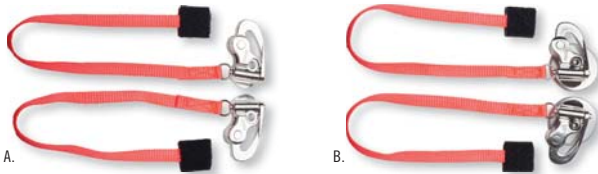

CODE	TYPE
A. AK1141.2	FITS SAH HELMET WITHOUT NUT WASHERS
B. AK1142.2	FITS SA HELMET

### M6 ANCHOR



CODE	TYPE
M61.HAK	
M61.HAK.SAH, WO WASHERS	

### SLIDING TETHER FOR POST COLLAR ANCHOR



CODE	TYPE
TK1131.3	SPORT II
TK1131	SPORT I, PROFESSIONAL
TK1231.4	ADJUSTABLE, PRO ULTRA (Shown)
TK1431.7	HANS III

### SLIDING TETHER FOR QUICK-CLICK ANCHOR



CODE	TYPE
TK1141.3	SPORT II
TK1141	SPORT I, PROFESSIONAL (Shown)
TK1241.4	ADJUSTABLE, PRO ULTRA
TK1441.7	HANS III

### PADDING



CODE	TYPE
K9	GEL KIT
K9	FOAM KIT

Colors: Black, Blue, Red, Yellow

### HANS BAG

Preformed bag protects your HANS from sunlight and scuffing

CODE	TYPE
23909	HANS BAG



RACING SUITS

SURROUND  
YOURSELF IN  
SAFETY



## SIMPSON FINANCING FOR RACERS

---

SEE PAGE 107 FOR APPLICATION

Racing can be a dangerous sport, and safety products often fall by the way when purchases for the car and entry fees are more critical. Simpson offers a finance program that helps to make safe racing affordable.

A new Snell 2015 helmet, the head restraint you know you need and the latest in racing suit technology can all be yours. It is easy to apply and we can often approve you the same day. Turn to page 107 for our simple application. Our safety experts are happy to walk you through the process and get your safety gear on the way to you before your next race.

## NOMEX® TECHNOLOGY RACE PROTECTION

---

DuPont™  
**Nomex®**

### PERFORMANCE & CONFIDENCE

Racing professionals can't have one without the other. That's why they wear racing suits made of DuPont™ Nomex® fiber. In fact, 95% of racers around the world trust the protection of Nomex® to keep them safe. It manages extreme heat, yet still delivers incredible comfort, style and durability – giving them the performance only Nomex® thermal technology can provide. Racing suits and apparel made of Nomex® fiber help play a pivotal role in providing the valuable seconds racing professionals need to escape fires that result from both on-track collisions and pit accidents.

### BUILT IN

Racing gear made of Nomex® is inherently flame resistant; the FR (flame resistant) protection is built into the fiber and cannot be washed out or worn away – ever. It won't melt or combust when exposed to flame and actually becomes thicker when exposed to intense heat forming a protective barrier between the heat source and the skin.

### TRUST

For more than 30 years, DuPont™ Nomex® has been the industry leader around the world in FR protection against the ever-present danger of fires at the racetrack.

95% of racers (NASCAR®, IRL, NHRA, WoO and IHRA) around the world, including their pit crews, rescue teams and track officials, trust and depend on the FR protection of racing suits made with DuPont™ Nomex®.

## SUIT TESTING

---

**THERMO-MAN®** is the most advanced life-sized thermal burn injury evaluation system in the world today. He can be exposed to various fire hazards through controlled burns to test burn protection properties of garment constructions, fabric weights, material types and garment design styles. Results predict the amount, degree and location of burn injuries that would be sustained by the wearer in a flash fire.

DuPont scientists use this information to help apparel manufacturers develop optimum designs in lightweight, flame-resistant suits that equip drivers, pit crews, rescue teams and track officials with garments that are comfortable and provide the best thermal protection possible.

## FABRIC COLOR RANGE

COLORS	WHITE	BLACK	NAVY BLUE	ROYAL BLUE	PACIFIC BLUE	SILVER	YELLOW	GOLDEN YELLOW	GOLD	GREEN	LIME GREEN	PURPLE	PINK	RED	ORANGE
<b>TITANIUM NOMEX®</b> Our lightest weight fabric. High luster finish. Excellent choice for custom design incorporating embroidery and trim.	•	•	•	•	•	•	•	•	•	•	N/A	•	N/A	•	N/A
<b>SIGNATURE KNIT NOMEX®</b> A lightweight comfortable fabric with excellent breathability. It offers superior fire protection, and a subtle stretch for added mobility.	•	•	•	•	N/A	N/A	•	N/A	N/A	•	N/A	N/A	N/A	•	•
<b>SATIN/TWILL</b> Semishiny woven fabric with a relaxed, soft and supple feel, available in a wide variety of colors.	•	•	•	•	N/A	•	•	•	N/A	•	•	•	•	•	•

• = Available N/A = Not Available

Satin/Twill also available in Pewter, Maroon and Brown.

## CUSTOM SUIT DESIGN OPTIONS TRIM CHARGES SHOWN ARE IN ADDITION TO THE BASE SUIT PRICE.

Custom suit design options, choose your colors from our wide selection.



## CUSTOM MADE-TO-ORDER RACING SUITS



Our Made-To-Order custom racing suits are made to order per your exact specifications at our factory in the USA. They are SFI approved and feature genuine DuPont™ Nomex® fabric. Our suits provide protection and comfort from over 14 measurements that are uniquely yours for a true custom fit. Our custom racing suits are offered in single layer, 2-layer and 3-layer suits as well as drag racing suits. Try our lumbar stretch panels for added comfort and ease of movement. Our large selection of color choices allows for compatibility with sponsor requirements.

### EACH MTO SUIT INCLUDES

- Custom fit with 14 different measurements
- Vertical quilt
- Choice of collar (banded, soft knit, wraparound)
- Zippered breast pocket on select styles
- Epaulets with Simpson logos included
- Name embroidered on front belt
- Inset front pockets
- Colored rib cuffs  
(Red, White, Blue or Black)
- SFI tags included where mandated



### Available Features

The suits pictured in our custom suit section are here to show you the multitude of style and material options that are available. When you see the Custom logo next to a racing suit, the product is available in custom colors and features. You are not limited by any of these designs in any particular suit style. Design your own suit with the available features below.

#### ADD ON FEATURES

- 360 DEGREE FULL ARM GUSSETS
- LOWER BACK EXPANDABLE GUSSET
- BOX QUILT MATCHED TO SUIT UNLESS CONTRASTING THREADS ARE REQUESTED
- REAR PATCH POCKET
- STRAIGHT LEG CUFF
- BUILT-IN ARM RESTRAINTS
- TWO PIECE SEPARATES, JACKET AND PANT
- HOOF OPTION, STRAIGHT LEG CUFF REQUIRED
- CUSTOM DESIGN AND EMBROIDERY AVAILABLE

#### RACER DELUXE PACKAGE: BEST VALUE!

- INCLUDES 360 DEGREE ARM GUSSETS, LOWER BACK GUSSET.

## CUSTOM DNA



The DNA suit combines industry changing innovations and advanced design in a suit that offers almost no restrictions to movement, unbeatable breathability and incredibly lightweight fabric. This game changing suit is constructed to meet the needs of our athletes on the track and loaded with features available only at Simpson.

CODE:  
MTO.26

### THE PACKAGE INCLUDES

SFI.5 approved Titanium Nomex® racing suit, Made in the USA

Integrated cuffs replace traditional sleeve cuffs, minimizing material at your wrist and eliminating bunching in the glove gauntlet area

X-Tech stretch elbows allow for effortless movement of the arms, helping with fatigue and stopping the sleeve from migrating up the arm

X-Tech stretch body panels reduce tension across the back, torso, waist, hips and thighs

Stretch panels offer improved ventilation in key area of the body  
Stylish outside pockets lay flat to eliminate bunching and require less material

Embroidered trim adds style without adding unwanted weight

### COLORS

See page 37



## DRIVER'S PERFORMANCE PACKAGE

### AMP UP YOUR CUSTOM SUIT!

Simpson's Driver Performance Package may be added to any custom suit.

CODE:  
**PERFPKG**

### THE PACKAGE INCLUDES

Fast back epaulets

Flying V quilting adds bold styling

Elbow stretch panels reduce arm fatigue

Front only half belt is non-binding

Neck, sides and lower back X-Tech stretch ventilation reduces binding and improves breathability

Innovative above the knee and crotch gussets reduce thigh and knee stress

Tapered leg minimizes excess material and reduces weight





## NEW PRO LITE CUSTOM DRAG SUITS



Less is more with our newest SFI 15 drag racing suit, the Pro Lite. Experience exceptional breathability and lightweight comfort without sacrificing protection. Custom in every way, our suits move with the racer allowing maximum comfort behind the wheel. Our exclusive materials provide strategic stretch without bulkiness, for a sleek presentation. Simpson is the official safety partner to John Force Racing, providing top quality gear for NHRA Funny Car champions John Force and Robert Hight and all of the JFR athletes. Shop our line of SFI 15 and SFI 20 suits here.



### sfi 3.2A/20

CODE MD.50W  
 FABRIC NEW PRO LITE NOMEX® / 1-PIECE  
 COLORS: Black, Blue, Red, White

### sfi 3.2A/20

CODE MD.50T  
 FABRIC SIGNATURE KNIT NOMEX® / 1-PIECE  
 COLORS: Royal Blue, White, Black, Navy, Red, Orange, Green, Yellow

CODE MD.50KS  
 FABRIC SATIN/TWILL 1-PIECE  
 COLORS: Royal Blue, White, Black, Navy, Red, Silver, Orange, Green, Purple, Yellow, Golden Yellow, Lime Green, Pink

### sfi 3.2A/15

CODE MD.40T  
 FABRIC SIGNATURE KNIT NOMEX® / 1-PIECE  
 COLORS: Royal Blue, White, Black, Navy, Red, Orange, Green, Yellow

CODE MD.40KS  
 FABRIC SATIN/TWILL 1-PIECE  
 COLORS: Royal Blue, White, Black, Navy, Red, Silver, Orange, Green, Purple, Yellow, Golden Yellow, Lime Green, Pink

#### FEATURES

2-Piece Drag Suits

Suit shown in Signature Knit Nomex fabric with custom trim designs.

Call for quote.

All SFI.15 and SFI.20 suits feature our standard vertical quilting; box quilting available upon request

Arm restraints, full arm gusset

ROBERT HIGHT 2017 NHRA FUNNY CAR CHAMPION



## CUSTOM SFI.1 AND SFI.5 RACING SUITS



### sfi 3.2A/1

CODE MTO.6  
 FABRIC SATIN/TWILL CUSTOM FIT  
 COLORS: Royal Blue, White, Black, Navy, Red, Silver, Orange, Green, Purple, Yellow, Golden Yellow, Lime Green, Pink

### sfi 3.2A/5

CODE MTO.26  
 FABRIC TITANIUM NOMEX®/CUSTOM DNA  
 COLORS: Royal Blue, White, Black, Red, Yellow, Golden Yellow, Silver, Gold, Navy, Pacific Blue

CODE MTO.24  
 FABRIC TITANIUM NOMEX® / CUSTOM FIT  
 COLORS: Royal Blue, White, Black, Red, Yellow, Golden Yellow, Silver, Gold, Navy, Pacific Blue

CODE MTO.25  
 FABRIC SIGNATURE KNIT NOMEX® / CUSTOM FIT  
 COLORS: Royal Blue, White, Black, Navy, Red, Orange, Green, Yellow

CODE MTO.21  
 FABRIC SATIN/TWILL CUSTOM FIT WITH KNIT RIB LINING  
 COLORS: Royal Blue, White, Black, Navy, Red, Silver, Orange, Green, Purple, Yellow, Golden Yellow, Lime Green, Pink

CODE MTO.22  
 FABRIC SATIN/TWILL CUSTOM FIT WITH FLEECE LINING  
 COLORS: Royal Blue, White, Black, Navy, Red, Silver, Orange, Green, Purple, Yellow, Golden Yellow, Lime Green, Pink

### sfi 3.2A/5

CODE MTO.33  
 FABRIC SIGNATURE KNIT NOMEX® / CUSTOM FIT  
 COLORS: Royal Blue, White, Black, Navy, Red, Orange, Green, Yellow

CODE MTO.33  
 FABRIC SATIN/TWILL CUSTOM FIT  
 COLORS: Royal Blue, White, Black, Navy, Red, Silver, Orange, Green, Purple, Yellow, Golden Yellow, Lime Green, Pink



## LIGHTWEIGHT AND NON-RATED FULLY SUBLIMATED CUSTOM SUIT



### IDEAL FOR KARTING OR PHOTOGRAPHY

Simpson's Non-FR Suits offer the professional look you want both on and off the track. By sublimating directly onto the fabric, we can offer a lightweight suit with endless color and design options. Sublimation reduces your cost by eliminating intricate embroidery. It is a vivid color process that will look as good at the end of the season as it did when you removed it from the box. Unlimited sponsor logos and lettering. Suit features: custom fit and tailored measurements, vertical quilt, choice of collar (banded, soft knit, wraparound), zippered breast patch pocket (not available for styles C/D/F/M/K/L), epaulets, name embroidery (standard type face on belt: Script), inset front pockets, and colored rib cuffs (Red, White, Blue, Black). Customer to supply vector artwork.



### Sublimated Kart Suit, 1 Piece

CODE: MK.TS  
 SIZE: CUSTOM FIT  
 FABRIC: 600 DENIER POLY

### Sublimated Kart Jacket

CODE: MT.KSJ  
 SIZE: CUSTOM FIT  
 FABRIC: 600 DENIER POLY

### Suit Options Available. Additional charges apply:

- FEATURES
- 360° FULL ARM SHOULDER GUSSET
- LOWER BACK EXPANDABLE GUSSET
- BOX QUILT (MATCHES SUIT COLOR: CONTRAST THREAD AVAILABLE)
- STRAIGHT LEG CUFF
- 2-PIECE DRIVING SUIT (SEPARATE JACKET & PANT)
- RACER'S DELUXE PACKAGE:  
*360° arm gussets, lower back gussets, straight leg cuff and full box quilt.*
- EMBROIDERY (CUSTOM LOGOS & GRAPHICS)



## SUIT SIZING

### SIMPSON STANDARD DRIVING SUIT SIZE CHART

SIZE	CHEST	WAIST	HIP	INSEAM	NECK	HEIGHT	WEIGHT
SMALL	30-34	26-30	33-37	31	14.5	5'5" TO 5'7"	115 TO 130
MEDIUM	34-38	30-34	37-41	32	15.5	5'7" TO 5'10"	140 TO 165
LARGE	38-42	34-38	41-45	33	16.5	5'10" TO 6'2"	175 TO 200
EXTRA LARGE	42-46	38-42	45-49	34	17.5	5'11" & OVER	210 TO 225
XX LARGE	46-50	42-46	49-53	35	18.5	5'11" & OVER	235 TO 250

### YOUTH DRIVING SUIT SIZE CHART

SIZE	CHEST	WAIST	HIP	INSEAM	NECK	HEIGHT	WEIGHT
EXTRA SMALL	28-31	21-24	26-29	22	11	4'0" TO 4'4"	50 TO 60
SMALL	31-33	24-26	29-31	23	12	4'1" TO 4'5"	60 TO 75
MEDIUM	33-36	26-28	31-33	24	13	4'5" TO 5'0"	75 TO 90
LARGE	36-38	29-31	34-36	26	13	5'0" TO 5'4"	90 TO 105
EXTRA LARGE	39-41	32-34	38-40	28	14	5'4" TO 5'6"	105 TO 120



JUSTIN ALLGAIER, JR MOTORSPORTS  
NASCAR XFINITY SERIES ATHLETE  
AND DAUGHTER HARPER

## HELIX RACING SUIT



The Helix driving suit belongs to our DNA strand of high-performance racing products. Simpson's DNA products are designed with athletic performance-enhancing features engineered to reduce weight and driver restrictions.

Available in Adult and Youth Sizing.

### FEATURES

- SFI.5 Rated
- 270 degree arm and back gussets
- Knee and Inner Thigh Stretch Panels
- Lower back stress relief panel
- Upper back ventilation port
- No bulk, weight-saving patch pockets and embroidered trim and logo

### COLORS

Black, Red



CODE:  
HX

SIZE:  
ADULT S - XXL

CODE:  
HX-Y

SIZE:  
YOUTH XS - XL

See page 54 for Youth Helix.





## DNA SFI 5 RACING SUIT **NEW LOWER PRICE**



Become One Step Ahead of Your Competition With Today's Most Advanced Racing Suit customized in your team and sponsor colors and logos. See page 39 for custom DNA.

Our Popular DNA suit combines industry changing innovations and advanced design in a suit that offers almost no restrictions to movement, unbeatable breathability and incredibly lightweight fabric. This game changing suit is constructed to meet the needs of our athletes on the track and loaded with features available only at Simpson. The DNA suit combines industry changing innovations and advanced design in a suit that offers almost no restrictions to movement, unbeatable breathability and incredibly lightweight fabric.

### FEATURES

SFI.5 approved Titanium Nomex racing suit, Made in the USA

Integrated cuffs replace traditional sleeve cuffs, minimizing material at your wrist and eliminating bunching in the glove gauntlet area

X-Tech stretch elbows allow for effortless movement of the arms, helping with fatigue and stopping the sleeve from migrating up the arm

X-Tech stretch body panels reduce tension across the back, torso, waist, hips and thighs

Stretch panels offer improved ventilation in key area of the body

Stylish outside pockets lay flat to eliminate bunching and require less material

Embroidered trim adds style without adding unwanted weight

### COLORS

Red/White, Blue/White, Black/White

### SUIT FABRIC

Titanium Nomex®



CODE:  
**DNA**

SIZE:  
**S, M, L, XL**

EMBROIDERY QUOTED SEPARATELY UPON REQUEST



### INTEGRATED CUFFS

replace traditional sleeve cuffs, minimizing material at your wrist and eliminating bunching in the glove gauntlet area



### X-TECH STRETCH ELBOWS

allow for effortless movement of the arms, helping with fatigue and stopping the sleeve from migrating up the arm

## NEW QUALIFIER RACING SUIT

Our newest two-layer construction SFI 3.2/5 racing suit is lightweight and extremely breathable and features our softest rib knit lining. The Qualifier has pre-curved floating sleeves and straight leg cuffs with a two-tone modern design.

### FEATURES

Satin Twill with soft rib knit lining  
Straight cut leg  
360° Full arm gusset  
Ultra-soft knit cuffs  
SFI 3.2A/5 certified

### COLORS

Black/Grey, Blue/Grey, Red/Grey

### FABRIC

Satin/Twill



### Q1 QUALIFIER RACING SUIT

CODE	SIZE: S-XXL
STD Q1	1-PIECE 15% UPCHARGE FOR XXL
STD Q1	PANT 15% UPCHARGE FOR XXL
STD Q1	JACKET 15% UPCHARGE FOR XXL



## HPD-1 RACING SUIT DUAL CERTIFIED!

FIA and SFI 3.2A/5 certified. With Sports Car, Rally and Road Racing in mind, Simpson's lightweight 3-layer, HPD-1 racing suit is loaded with functionality and performance. Impressive features include raglan style epaulettes, heat relief panels in back of neck, 360° arm gussets, stretch panels at the elbow and thigh area, front half belt, and white/red or white/gray color combinations. Coordinating arm and leg cuffs and an attractive quilt stitch pattern finish out this suit. The HPD-1 is simplistic in design and loaded with functionality.

### COLORS

White/Red Trim, White/Gray Trim

### FABRIC

Satin/Twill



CODE:	SIZE:
RS	US: S - XL EURO: 48, 50, 52, 54



# RACING SUITS

## VIXEN II FEMALE RACING SUIT

We love the Vixen II redesign that offers SFI 3.2/5 protection in a comfortable and stylish suit designed to accentuate curves and move with the racer. We began with the finest fabric interior and Shiny Twill outer layer. The Vixen II provides maximum protection from burn situations while at the same time delivering style and attention to detail. The design curves smoothly along the body shape with strategic darts, providing less bulk and a sleek silhouette. The front pockets lay flat and special attention has been given to the bust, waist and hip area, offering a proportion that is both desirable and wearable to our female racers.

### COLORS

Ebony Black with White Trim

Ebony Black with Pink Trim

Call for additional color options

### FABRIC

Satin/Twill Satin Twill outer with soft knit ribbed interior



CODE:  
STD.18

SIZE:  
XS - L, (XS 0-2, S 4-6, M 8-10, L 12-14)

**NEW COLOR!**

COURTNEY FORCE, JOHN FORCE RACING ATHLETE AND NHRA FUNNY CAR DRIVER



## SUPER SPORT RACING SUIT

Satin/Twill suit with vertical quilting and fleece inner lining of 100% Nomex®. Featuring inset pant pockets, straight leg cuffs. Available in both 1-piece and 2-piece design.

### COLORS

Black, Red, Royal Blue

### FABRIC

Satin/Twill with fleece lining



### Super Sport

CODE  
STD.SS

SIZE: S-XXL  
1-PIECE  
15% UPCHARGE FOR XXL

STD.SS

PANT  
15% UPCHARGE FOR XXL

STD.SS

JACKET  
15% UPCHARGE FOR XXL

STD.SS

JACKET WITH RESTRAINTS  
15% UPCHARGE FOR XXL



## SPORTSMAN ELITE II RACING SUIT



The Sportsman Elite II suits come with many of the same features as our MTO suits at half the price. Contrasting Platinum chest band and extensive white piping, banded collar, 360° arm gusset, 3-point epaulets, patch style pockets, straight leg cuffs, colored rib cuffs and vertical quilting.



### Sportsman Elite II

CODE	SIZE: S-XXL
STD.15	1-PIECE
	15% UPCHARGE FOR XXL
STD.15	JACKET
	15% UPCHARGE FOR XXL
STD.15	JACKET WITH BUILT-IN ARM RESTRAINT
	15% UPCHARGE FOR XXL
STD.15	PANT
	15% UPCHARGE FOR XXL

#### COLORS

Black, Red, Royal Blue

#### FABRIC

Satin/Twill with fleece lining

## SFI-5 CLASSIC RACING SUIT



Our SFI-5 suit features woven Satin/Twill fabric with vertical quilting and zippered patch style breast pocket, straight leg cuff available.

#### COLORS

Black, Red, Royal Blue

#### FABRIC

Satin/Twill with fleece lining



### SFI-5 Classic

CODE	SIZE: S-XXL
04 STD.19	1-PIECE
	15% UPCHARGE FOR XXL
04 STD.19	JACKET
	15% UPCHARGE FOR XXL
04 STD.19	JACKET WITH BUILT-IN ARM RESTRAINTS
	15% UPCHARGE FOR XXL
04 STD.19	PANT
	15% UPCHARGE FOR XXL

## SFI-1 CLASSIC RACING SUIT



The SFI-1 suit features our Classic 3-stripe design in woven Satin/Twill with a zippered breast pocket. (2 piece shown)



**FABRIC**  
Satin/Twill

### SFI-1 Classic

CODE	SIZE: S-XXL
03 STD.6	1-PIECE
	15% UPCHARGE FOR XXL
03 STD.6	JACKET
	15% UPCHARGE FOR XXL
03 STD.6	PANT
	15% UPCHARGE FOR XXL

## LEGEND II RACING SUIT



The Legend II is an affordable SFI.1 rated racing suit tailored to the needs of the racer. We have added distinctive styling and 3-point epaulets. This entry-level FR Cotton suit includes a wraparound collar and 3-point epaulets with Simpson branding. We have also included vertical quilting, 360° full arm gussets, straight leg cuffs and front pockets. Choose from a complete range of Adult and Youth sizes.

**COLORS**  
Solid Black, Black/Gray Combo (not shown)

**FABRIC**  
SFI-1 FR Cotton



CODE: **STD.LII**      SIZE: **S - XL**

YOUTH LEGEND II AVAILABLE, SEE PAGE 54.

## SFI-15/SFI-20 DRAG RACING SUITS



Standard drag racing suits include contrasting piping, full arm gussets, SFI tag, built-in arm restraints and vertical stitching.

The suit is shown with box quilt and comes standard with vertical quilt.

### COLORS

Black, Red, Royal Blue (not shown)



### SFI-15 Drag Racing Suit

CODE  
STD.49T  
STD.49T

FABRIC  
SIGNATURE KNIT NOMEX® / 1-PIECE  
SIGNATURE KNIT NOMEX® / 2-PIECE PANT & JACKET

### SFI-20 Drag Racing Suit

CODE  
STD.48T  
STD.48T

FABRIC  
SIGNATURE KNIT NOMEX® / 1-PIECE  
SIGNATURE KNIT NOMEX® / 2-PIECE PANT & JACKET

## HOLESHOT 20 DRAG GLOVE

The Holeshot 20 Drag Glove is SFI 3.3/20 approved and made in the USA and is 20% lighter than the competition. Newly developed Nomex® technology with conforming stretch for improved dexterity.

**COLOR**  
Black



CODE:  
**37015**

SIZE:  
**S - XL**

## HOLESHOT 20 DRAG BOOTS



The Holeshot 20 Drag Boot is SFI 3.3/20 approved and made in the USA and is 50% lighter than standard drag boots. Newly developed Nomex® material stretches over the shoe for improved fit and comfort. Includes zipper and adjustment strap.

**COLOR**  
Black



CODE:  
**37021**

SIZE:  
**S - XL**

FOOT SIZE	5½-7"	7-8½"	8½-10"	10-11½"	11½-13"
SHOE SIZE	S	M	M/L	L	XL

# RACING SUITS



## NEW UTV SPORT VINTAGE STYLE SUIT



UTV Suit features our popular 3 stripe retro styling  
 One-piece suit meets and exceeds SFI 3.2A/1 and SFI 5 3.2/5 requirements  
 Black Ankle and Wrist Cuffs  
 Standard Shoulder Epaulets  
 Red, Orange and Yellow racing stripes on driving suit arms

### SIZES

Small – XXL Large, 15% upcharge for XXL

### COLOR

Black Only

CODE: **U3** SIZE: **SFI 3.2/1 RATED**

CODE: **U4** SIZE: **SFI 3.2/5 RATED**

## CROSSOVER RACING SUIT



The Crossover suit is SFI.5 rated with multilayers of fire protection. Simpson branded at epaulets. Banded collar and straight leg cuffs. Back gusset is designed for comfort. Includes 360° arm gussets.

### COLORS

Red/White/Black, Black/White/Gray or Gray/White/Graphite (not shown)

### FABRIC

Satin/Twill

CODE: **STD.CO** SIZE: **S-XXXL (XXL, XXXL PLUS %15)**



## APEX KART RACING SUIT

The Apex Suit is ergonomically designed to offer resistance abrasion for karters and stylish visibility on the track. The fabric is lightweight, fade resistant and durable. Non-restrictive stretch panels enhance the racer's comfort.

### FEATURES

Lightweight Cordura® construction is highly resistant to abrasion  
 Soft mesh inner lining at the sleeve and thigh areas for comfort and breathability and maximum air flow  
 Fully floating arms minimize bulk around the shoulders  
 Knit wrist and ankle cuffs offer a sleek fit  
 Fully adjustable collar and front belt  
 Attractive modern style epaulets

### COLORS

Black w/Gray Trim, Red w/Gray Trim (shown)



CODE:  
AP

SIZE:  
S, M, L, XL

## APEX KART GLOVE

The Apex glove is styled for karting and enthusiasts and is not an SFI rated glove.

### COLORS

Black, Blue, Red



CODE:  
AX

SIZE:  
XS-XXL

## APEX KART RACING JACKET



### FEATURES

Jacket features extended back heatshield panel across shoulder area for added protection  
 Upgrade with a rear tuck flap extension/  
 Call for pricing 704 662-3366  
 Comes standard with white stripes, optional black stripes shown

### COLORS

Black, Red (not shown)

### FABRIC

Poly Duck

NO TPP RATING. NOT FIRE RETARDANT.



CODE:  
01 STD. K

SIZE:  
S - XXL 15% UPCHARGE FOR XXL

## JR/YOUTH RACING SUITS

### HELIX YOUTH RACING SUITS



The Helix SFI 5 Youth driving suit is designed with athletic performance-enhancing features engineered to reduce weight and young driver restrictions. The Helix is available in Adult and Youth Sizing.

#### FEATURES

- SFI.5 Rated
- 270 degree arm and back gussets
- Knee and Inner Thigh Stretch Panels
- Lower back stress relief panel
- Upper back ventilation port
- No-bulk, weight-saving patch pockets and embroidered trim and logo.



CODE:  
**HX-Y**

SIZE:  
**XS - XL**



**COLOR**  
Black/Grey

**FABRIC**  
Satin/Twill

### SFI.5 BASIC AND PREMIUM YOUTH SUITS (NOT SHOWN)



#### FEATURES:

- Solid color suit
- Double racing stripes on arms and legs. Simpson logos on arms and cuffs
- Stylish inset pockets and banded collar
- Traditional cuff leg, basic model
- Straight leg cuff, premium model

#### COLOR SELECTION

Black, Blue and Red

CODE:  
**STD.Y4**  
**STD.P4**

SIZE:  
**BASIC MODEL, XS-XL**  
**PREMIUM MODEL, XS-XL**



### YOUTH LEGEND II SUIT



The Youth Legend II Suit is an affordable SFI.1 rated cotton firesuit tailored to the needs of the young racer. We have added distinctive styling and attractive color combinations. This quality sewn FR Cotton suit includes a wraparound collar and 3-point epaulets with Simpson branding. The Legend II has vertical quilting, 360 degree full arm gussets, straight leg cuffs and front pockets.

CODE:  
**STDY.LYII**

SIZE:  
**YXSM, YSM, YMED, YLG, YXL**

SEE YOUTH SIZE CHART ON PAGE 44.

#### COLORS

Black with White trim, Black with Red trim

#### FABRIC

SFI-1 FR Cotton

### JR KART SUITS (NOT SHOWN)

Karting suits are not SFI rated. Constructed of 600 Denier Poly, single layer.

#### KART SUIT COLORS

Black, Blue and Red

CODE:  
**STD.Y1**  
**STD.P1**

SIZE:  
**BASIC MODEL, XS-XL**  
**PREMIUM MODEL, XS-XL**

## MEMORY FIT UNDERWEAR



Our newest fire retardant memory fit underwear is race tested by NASCAR's pro racers. The unique memory fit fabric stretches both horizontally and vertically with great bounce back and becomes softer with each washing. You may want to order two sets, because this will quickly become your go-to underwear for added race protection.

### FEATURES

- SFI 3.3 Certified
- Made in the USA
- Nomex® blend provides added fire protection
- Anti-microbial treated
- No bulk, unique memory stretch provides built in comfort, while retaining shape
- Contrast stretch stitching for definition

### Memory Fit

CODE	MEMORY FIT LONG SLEEVE TOP
20123	MEMORY FIT BOTTOM
20124	MEMORY FIT SHORT SLEEVE TOP
20125	



## LADIES FR BRA



Top is constructed of 4-way stretch Nomex® protective fabric and functions as an added layer of protection and improved comfort under a racing suit. This safe alternative to unisex undergarments is free of dangerous underwire, snaps and hooks. The Simpson sports top is designed with soft comfort in mind. The wide chest band and shoulders stay in place and are non-binding.

CODE: **20606**      SIZE: **XS - XL**

CHEST BAND SIZE	28"/30"	30"/32"	32"/34"	34"/36"	36"/40"
SIMPSON BRA SIZE	XS	S	M	L	XL

\* WEARING NYLON OR POLYESTER WHILE RACING IS NOT RECOMMENDED. THESE MATERIALS CAN MELT WHEN EXPOSED TO EXTREME HEAT AND CAN CAUSE SERIOUS INJURIES.

**COLOR**  
Black



## CarbonX® ULTIMATE™ UNDERWEAR



CarbonX® delivers base layer products with extraordinary thermal protective properties, including CarbonX® Ultimate™ Underwear. (XXL available with 15% upcharge).

**COLOR**  
Black



LONG SLEEVE AVAILABLE

### CarbonX® Ultimate™

CODE	SIZE: S-XXL
20600	LONG SLEEVE TOP
20601	BOTTOM
20602	SHORT SLEEVE CREW NECK TOP <i>NOT SFI CERTIFIED</i>

## 70Z. (NOT SHOWN)



**COLORS**  
Natural, Black

### 70Z.

CODE	SIZE: S-XXL
20000	LONG SLEEVE TOP (XXL AVAILABLE WITH 15% UPCHARGE)
20001	FULL LENGTH BOTTOM (XXL AVAILABLE WITH 15% UPCHARGE)

### SAFETY TIP

*Nomex® or CarbonX® underwear underneath the racing suit will dramatically improve Thermal Protection Performance (TPP) in the case of an accident involving fire.*

## NOMEX® UNDERWEAR

Our softest Nomex® knit for added comfort. Available in short or long sleeve and full length bottom. Meets SFI 3.3 and includes tag. Youth sizes available.



### Nomex® Underwear

CODE	SIZE: S-XXL
20100	SHORT SLEEVE TOP (XXL AVAILABLE WITH 15% UPCHARGE) <i>NOT SFI CERTIFIED</i>
20110	LONG SLEEVE TOP (XXL AVAILABLE WITH 15% UPCHARGE)
20101	BOTTOM (XXL AVAILABLE WITH 15% UPCHARGE)



## KEVLAR® SLEEVE & GLOVES

Designed for mechanics and crew members to help prevent cuts or burns while working a hurried pit stop. Can be worn under SFI-20 driving glove for added protection.



CODE:  
**39024**

SIZE:  
**ONE SLEEVE / ONE SIZE**

CODE:  
**39020**

SIZE:  
**GLOVES / S - XL**

## FUELER APRON

Includes adjustable Kevlar straps.

**COLOR**  
Silver



CODE:  
**39042**

SIZE:  
**ONE SIZE**

## MECHANICS APRON

Polyester cotton blend. one upper pocket.  
Includes adjustable nylon straps.

**COLOR**  
Black



CODE:  
**39035**

SIZE:  
**ONE SIZE**

## PROTECTIVE ACCESSORIES

### FIA NOMEX® BALACLAVA

Simpson's FIA Nomex Balaclava features a frontal design utilizing a dual layer of Nomex® for increased protection.

**COLOR**  
Natural



#### FIA Nomex® Balaclava

CODE	TYPE
23004W	SINGLE EYEPORT
23005W	DUAL EYEPORT

### CarbonX® BALACLAVA

Delivers Ultimate™ protection to the critical face and neck areas. Moisture wicking. Fits any full face helmet contour; wear in or out. Includes SFI tag.

**COLOR**  
Black



#### Carbon x® Balaclava

CODE	TYPE
23000C	SINGLE EYEPORT
23003C	DUAL EYEPORT

### MEMORY FIT BALACLAVA

The lightweight unique memory fit fabric stretches both horizontally and vertically for an overall comfortable fit.

**COLORS**  
Black, White (not shown)



#### Memory Fit Balaclava

CODE	TYPE
23050	SINGLE EYEPORT
23051	DUAL EYEPORT

### SFI NOMEX® BALACLAVA

Knitted from extra-plush Nomex®. Designed to be worn under most helmets. Single or dual eye port. Includes SFI tag. Youth sizes available.

**COLORS**  
Natural, Black (not shown)



#### SFI Nomex® Balaclava

CODE	TYPE
23000	SINGLE EYEPORT
23003	DUAL EYEPORT



### NOMEX® HELMET SKIRT

Dual layer material. Keeps dust and debris out of helmet. Attaches easily with speed fit system. Includes SFI tag.

**COLORS**  
Black, Natural (not shown)



#### Nomex® Helmet Skirt

CODE	TYPE
23012	STANDARD
23013	CONTOURED
23014	LARGER HELMET OPENING

### CarbonX® HELMET SKIRT (NOT SHOWN)

Dual layer CarbonX® fleece material to comfortably protect neck and head.

**COLOR**  
Black



#### Nomex® Helmet Skirt

CODE	TYPE
23012C	STANDARD
23013C	CONTOURED
23014C	LARGER HELMET OPENING



## MOLECULE PERFORMANCE PRODUCTS

Molecule Car Cleaner removes road grime with ease, specifically addressing racing grime. Our detailer is easy to apply and quickly buffs to a glassy shine. Our fabric care products bond to Nomex® fabric to help repel flammable stains. Molecule Wash and Refresh keeps gear cleaner and safer by resisting contaminants that can degrade fabric performance. Protector sheds water, oils, fuels and dirt. Maintains fabric breathability. Fabric sunscreen reduces color fading caused by UV rays. Safe, water-based, patent pending formula.



FOR THE CAR DETAILER AND CLEANER



FOR THE RACER



### Helmet and Shield Care

CODE	TYPE	SIZE
MLHCP4	HELMET CLEANER/POLISH	4 OZ. SPRAY
MLHFR4	HELMET FABRIC REFRESH	4 OZ. SPRAY
MLHRR4	HELMET RAIN REPEL	4 OZ. SPRAY
MLHAF4	HELMET ANTI FOG	4 OZ. SPRAY

### Car Care

CODE	TYPE	SIZE
MLDET16	DETAILER	16 OZ.
MLCLE16	CLEANER	16 OZ.

### Protective Fabric Care

MLWK161	WASH KIT: INCLUDES 16 OZ. WASH AND 16 OZ. SPOT REMOVER	16 OZ.
MLWTK44	TRIAL WASH KIT: INCLUDES 4 OZ. WASH AND 4 OZ. SPOT REMOVER	4 OZ.
MLWA16	WASH	16 OZ.
MLSP16	SPOT REMOVER	16 OZ. SPRAY
MLRE16	REFRESHER	16 OZ. SPRAY
MLPR16	PROTECTOR	16 OZ. SPRAY
MLCK1	COMPLETE CARE KIT: INCLUDES 4 OZ. SPOT REMOVER, 16 OZ. WASH, 16 OZ. REFRESHER, 16 OZ. PROTECTOR	16 OZ.

## NEW SONOMA PERFORMANCE CREW SHIRT

The Sonoma features an athletic fit, 3 button style and Simpson bar logo on the sleeve. Our most breathable fabric and tasteful contrast piping finish out this winning shirt.

### COLORS

Red/Black, Grey/Black, Blue/Black

CODE: **39018** SIZE: **S - XL**

CODE: **39018** SIZE: **XXL AND XXXL**



# RACING SUITS

## TALLADEGA BUTTON DOWN

The Talladega features embroidered Simpson "S" logo, contrasting piping, attractive contrasting fabric (65% Poly, 35% Cotton), breathable mesh side panels and a stylish fit.

### COLORS

Red/Black, Gray/Black, Blue/Black, Orange/Black, Yellow/Black, Black/Black



CODE:  
39012

SIZE:  
S - XL

CODE:  
39012

SIZE:  
XXL - XXXL

## CUSTOM SUBLIMATED CREW SHIRTS



Simpson makes thousands of sublimated crew shirts every year at our state-of-the-art racing suit and crew apparel manufacturing facility in Harbor City, California. When it comes to crew apparel, we know our business. In keeping with the colorful and sponsor-rich world of racing, our sublimation process allows for endless design and color combinations. Our selection of fabrics and style are durable and comfortable. Our service is impeccable, our in-house design staff is the best.

### FEATURES

- Sublimated shirts are an economical option on high-volume orders
- Mesh, dazzle and poly poplin fabric choices
- Hidden snap-front closure or 1/4 zip
- Hidden snap-down collar
- Front welt pockets where applicable
- Larger sizes available, call for price quote



### Custom Sublimated Crew Shirts

CODE  
SUBLIMATED CREW SHIRTS

SIZE:  
S - XXL  
WOMEN'S SIZES ARE AVAILABLE

BASE PRICE  
BASED ON QUANTITY

A person is shown from the chest up, wearing a black and tan work glove on their right hand. The glove has a red and black logo on the back of the hand that says "SIMPS". The person is holding a tool, possibly a wrench, and is working on a piece of machinery. The background is a workshop with various tools and equipment. The entire image has a warm, orange-red color cast.

GLOVES

GET AN  
ACCESSORY  
THAT'S A NECESSITY

# GLOVES

## DNA GLOVE

The DNA Glove is a high-performance driving glove constructed using knit Nomex® that conforms to each individual driver's hands for a unique custom fit. SFI 3.3/5 certified, the DNA glove features external seams, tapered and precurved fingers, precurved palm, exclusive DNA design silicone palm and finger grips, strategically placed knuckle and wrist bone padding and performance-inspired style lines. Wear the DNA for unmatched comfort & performance.



CODE:  
DG

SIZE:  
S-XL



### COLORS

Black/White, Black/Blue, Black/Red



## THE VORTEX GLOVE

SFI 3.3/5 rated and FIA Approved professional racing glove with Nomex® construction. Strategically placed wristbone padding provides additional protection. External seams and precurved palms provide comfort. Tapered and precurved fingers and fourchettes give the driver excellent control. Silicone palm gripper design and striking embroidered knuckle logo.

### COLORS

White/Black or White/Grey, both with Red Premium Trim design



CODE:  
VR

SIZE:  
XS - XXL

CODE:  
VR-F

SIZE:  
FIA APPROVED



## COMPETITOR GLOVE

Nomex® Construction with a distinctive white trim. The silicone palm and touchpoints give superior grip and limited bunching. Available with inside and outside seams.



Competitor Glove

CODE  
21300

FITS  
S - XL, ALL COLORS  
XXL, BLACK ONLY



## FIND YOUR GLOVE SIZE

### TO FIND YOUR GLOVE SIZE IN INCHES:

First, measure around the largest part of the hand over the knuckles while making a fist, excluding thumb.

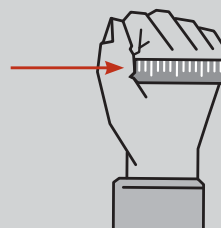

5" to 6"	XXS
6" to 7"	XS
7" to 8½"	S
8" to 9½"	M
9" to 10½"	L
10" to 11½"	XL



## THE HI-VIS GLOVE



SIMPSON GLOVES  
FEATURING  
**NOMEX**  
© PPD

The Hi-Vis glove has been developed for professional drivers who like the feel of an all-leather palm. SFI 3.3/5 Rated Racing Glove with Nomex® construction.

CODE:  
**HV**

SIZE:  
**XS - XXL**

### COLORS

Black w/Yellow Trim, Yellow w/Black Trim



## NEW WHEELER GLOVE

Certified to SFI 3.3/5 standard, the aggressively styled Wheeler Racing Glove features minimal seam construction and optimized levels of grip via a newly designed leather palm and fingers.

### FEATURES

SFI 3.3/5 Certified  
Fire-resistant aramid fiber main construction  
Mid length gauntlet with convenient pull tab

### COLORS

Black/Red and Black/White



CODE:  
**WH**

SIZE:  
**XS - XXL**



## PREDATOR GLOVE



SIMPSON GLOVES  
FEATURING  
**NOMEX**  
© PPD

Lightweight Nomex® construction for ultimate comfort and fit. Digital fire-resistant leather with individual performance stress points. All Nomex®, extra-long gauntlet with forearm cuff for custom fit.

CODE:  
**20800**

SIZE:  
**S - XL**

### COLORS

Black, White



# GLOVES

## IMPULSE GLOVE

The Impulse Professional racing glove provides protection and grip in all the right areas. SFI 5 Rated Racing Glove with Nomex® construction. Exceptionally soft palm constructed of goat leather. Inside Seams.

### COLORS

Red, Blue, Black



SIMPSON GLOVES  
FEATURING  
**NOMEX**  
®/TM

CODE:  
**IM**

SIZE:  
**XXS - XXL**



## SUPER SPORT GLOVE

The Super Sport is an entry-level racing glove that protects and performs. SFI 3.3/1 Rated Racing Glove with Nomex® construction and silicone graphics finish out design. Available with inside seams only.

### COLORS

Black w/White Graphic Trim



SIMPSON GLOVES  
FEATURING  
**NOMEX**  
®/TM

CODE:  
**SS**

SIZE:  
**XS - XL**

## YOUNG GUN YOUTH GLOVE

Double-layer Nomex® knit construction with an SFI 3.3/5 rating. The Young Gun is super stylish and super protective. Available in kids' sizing Small, Medium and Large.

### COLOR

Black with White with Silver accents



SIMPSON GLOVES  
FEATURING  
**NOMEX**  
®/TM

CODE:  
**YGY**

SIZE:  
**S - L**



## HOLESHOT 20 DRAG GLOVE

Made in the USA. Meets SFI 20. 20% lighter than the competition. Newly developed Nomex® technology with conforming stretch for improved dexterity.

### COLOR

Black



SIMPSON GLOVES  
FEATURING  
**NOMEX**  
®/TM



CODE:  
**37015**

SIZE:  
**S - XL**

## WRENCHER II MECHANIC GLOVE

One tough glove built for everyday wear for riding your bike or UTV or hanging out in the garage. The Wrencher II is not fire-retardant. The Wrencher II runs small. Order one size up for best fit.

### COLOR

Black



CODE:  
**39034**

SIZE:  
**S - XL**



## CUSTOM GLOVE PROGRAM

You can order our Team Style SFI.5 certified glove with your own team logos and colors. See our stylish and functional Team Glove here. Our Team Glove features Nomex™ construction with silicone palm and touchpoints and outside seam construction.

### COLORS

We offer multiple color choices. Contact us for details.

### HOW IT WORKS

#### 1. CHOOSE YOUR COLOR

Choose from the Nomex® constructed Black/White Team Glove. Featuring superior grip with silicone palm and touchpoints. This SFI certified glove is a popular choice for race teams.



SIMPSON GLOVES  
FEATURING  
**NOMEX**  
GLOVES



GLOVE IS SHOWN IN OPTIONAL CUSTOM COLOR, YELLOW.

#### 2. CHOOSE YOUR LOGO POSITION

Place your logo/art in the 3" by 7" print area. Also choose Position 1 or 2 for the Simpson logo.

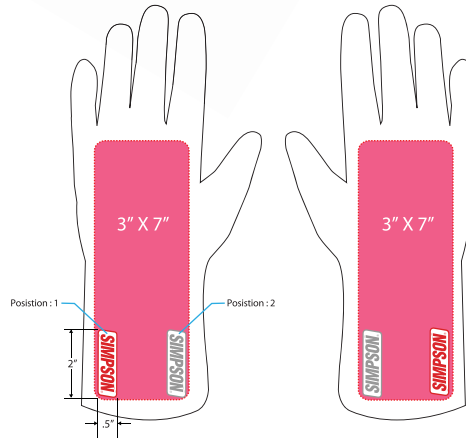

← Large area for your artwork. Excellent position for camera exposure.

#### 3. CHOOSE YOUR QUANTITY

Cost is based on your total quantity of pairs ordered with a unique print. Pricing is also based on the Simpson logo being on the glove.

PAIR(S):	1 – 6
PAIRS:	7 – 12
PAIRS:	13 +

#### 4. CALL SIMPSON

You will be required to supply your custom, hi-resolution artwork.



SHOES

THERE'S NO PLACE LIKE  
**VICTORY**  
LANE



## DNA SHOE

The DNA Shoe is our newest slim, lightweight, form-fitting performance shoe with heat-releasing perforated panels designed to meet the needs of today's fastest drivers.

### FEATURES

- SFI 3.3/5 certified
- DuPont™ Nomex® lining
- Push tongue and ankle padding
- Exclusive pedal-sensitive rubber sole

### COLORS

Black/White, Black/Red



CODE:  
DA

SIZE:  
4 - 14 (INCLUDES 1/2 SIZES)



## CIRCUIT PRO SHOE

This Circuit is made from imported, ultrasoft satin suede with fleece fire-retardant lining and features anatomical construction. This lightweight shoe has exceptional pedal response. The padded ankle support and flat seams provide excellent comfort in a mid-top shoe. A single speed fit closure locks away shoelaces.

**COLOR**  
Black



CODE:  
CP

SIZE:  
6 - 14 (INCLUDES 1/2 SIZES)

## REDLINE SHOE

The Redline shoe is SFI approved for racing and features a performance-enhancing, streamline design that is comfortable and pliable.

### FEATURES

- Manufactured of top grain leather and fire-retardant Nomex®
- SFI, FIA approved
- Hidden laces
- Textured bumper panels
- Single large Velcro ankle strap

### COLORS

Black/White, Black/Grey



CODE:  
RL

SIZE:  
6 - 14 (INCLUDES 1/2 SIZES)

CODE:  
RL-F

FIA, BLACK/GREY

## ADRENALINE SHOE

The Adrenaline is made from satin suede with a fleece fire-retardant lining and is SFI 3.3/5 approved. Triple layer anterior toe area for added wear protection with additional reinforcements in the heel and a speedfit lace closure. The low cut Achilles support gives maximum flexibility and comfort. The non-slip, super-sensitive polyurethane sole with posi-grip traction keeps you grounded.

**COLOR**  
Black



CODE: **AD**      SIZE: **4 - 14 (INCLUDES 1/2 SIZES)**

CODE: **AD**      SIZE: **YOUTH 1 - 3 (NO 1/2 SIZES)**



## MIDTOP SHOE

The Midtop shoe is SFI 3.3/5 certified. A single speed-fit closure locks away laces. Achilles relief cut for maximum flexibility. Fleece FR lining. Satin suede toe, heel and lace guard reinforcements. Triple layer anterior toe area for added wear protection. Non-slip, super-sensitive polyurethane sole with posi-grip traction.

**COLORS**  
Two-tone: Black and Grey.



CODE: **MT**      SIZE: **6 - 14 (INCLUDES 1/2 SIZES)**



## HIGHTOP SHOE

The Hightop is a high-top design with a satin suede upper and is SFI 3.3/5 approved. The inner fleece lining is FR. There is a triple layer anterior toe area for added wear protection with additional reinforcements in the heel and lace guard. Double speed-fit closure. The outer sole is a non-slip, super-sensitive polyurethane sole with posi-grip traction.

**COLORS**  
Black, Blue, Red



CODE: **28000**      SIZE: **4 - 14 BLACK (INCLUDES 1/2 SIZES)**

CODE: **28000**      SIZE: **8 - 12 BLUE, RED (INCLUDES 1/2 SIZES)**



## STEALTH SPRINT SHOE

The softer leather Stealth is SFI 3.3/5 approved with a modified lace guard for those who prefer a futuristic look. The high-top design features Simpson's easy to clean leather upper and super smooth leather toe, lace and heel guard reinforcements. The dual speedfit closure and exclusive EnviroGuard lace cover protects the seven hole lace-up. The internal construction features flat seams and fleece fire-retardant lining with an athletic insert. The outer sole is constructed of Type R polyurethane in a posi-grip pattern.

**COLOR**  
Black



SIMPSON SHOES  
FEATURING  
**NOMEX**  
© FPO

CODE: **SP**      SIZE: **6 - 14**

CODE: **SP**      SIZE: **8 - 12 (AVAILABLE IN 1/2 SIZES)**

## HOLESHOT 20 DRAG BOOT

The Holeshoot Drag Boot is SFI 3.3/20 approved and made in the USA, and is 50% lighter than standard drag boots. Newly developed Nomex® material stretches over the shoe for improved fit and comfort. Includes zipper and upper adjusting strap.

**COLOR**  
Black



SIMPSON SHOES  
FEATURING  
**NOMEX**  
© FPO



CODE: **37021**      SIZE: **S - XL**

FOOT SIZE	5½-7"	7-8½"	8½-10"	10-11½"	11½-13"
SHOE SIZE	S	M	M/L	L	XL



# SHOES

## PIT BOX SHOE



The Pit Box shoe is engineered to meet the demands of today's over-the-wall athletes. Lightweight but extremely tough, this shoe is made to be quick & hold up to the demands of any pit crew.

### FEATURES

- SFI 3.3/5 certified
- Velcro closure
- Internal ankle protection
- Lace protection
- Durable toe guard
- Speed styling and design

### COLOR

Black



CODE:  
PB

SIZE:  
7 - 17 (INCLUDES 1/2 SIZES)

## GARAGE CREW SHOE

Simpson's Garage Crew Shoe resists abrasion and provides traction and stability in an everyday work environment. It is all in a day's work when you wear Simpson's crew shoe. Our Garage Crew Shoe is made for superior service with an upper that features suede and abrasion-resistant canvas. A durable cushioned interior wicks away moisture, while non-marking, slip-resistant outer soles provide reliable traction.

### FEATURES

- Round soft toe and cushioned soles
- Non-marking, slip-resistant outer sole

### CARE

We recommend Molecule Spot Cleaner and Molecule Refresh products to keep your Simpson shoes looking their best.

### COLOR

Black



CODE:  
57000

SIZE:  
4 - 14 (INCLUDES 1/2 SIZES)

\*Shoe longevity varies based on user wear

## FR SHOE LACES

### COLOR

Black



CODE:  
FRLACES

SIZE:  
48"

ACCESSORIES

VO2FX™ 15/20 COMPRESSION SOCKS



Available in fire-retardant and non-FR crew models. Provides increased endurance. Prevents swelling caused by extended sitting or driving. Encourages increased circulation which increases oxygenated blood to muscle tissues, tendons and joints of the lower extremities. Reduces muscle soreness and danger of blood clots. COOLMAX® moisture management fabric keeps feet cool and dry. No in-shoe sliding.



Compression Socks

CODE  
23030  
23041

FITS  
SFI 3.3 FIRE-RETARDANT COMPRESSION SOCK  
NON-FR CREW COMPRESSION SOCK

**SIZES**  
M - XL



SFI 3.3 CarbonX® SOCKS



Knitted from patented CarbonX® yarn and flame-resistant, super-washed merino wool. Reinforced toe and heel, cushioned sole. CarbonX® is black in its pure form and cannot be dyed any other color.

CODE:  
23029C

SIZE:  
ONE SIZE FITS MOST

**COLOR**  
Black

NOMEX® SOCKS



Knitted from Nomex.

**COLORS**  
Black, White



CODE:  
23027

SIZE:  
ONE SIZE TUBE STYLE

Knitted from extra-plush Nomex.

**COLOR**  
White



CODE:  
23032

SIZE:  
S - XL

FOOT SIZE	6-8½"	8-10"	9-11"	10-14"
SHOE SIZE	S	M	L	XL



**HARNESSES**

**USE WHAT'S  
HOLDING  
YOU BACK TO  
RACE AHEAD**



## SIMPSON HARNESSES

Simpson Harnesses are SFI Approved. Upgrade to Platinum Plus Camlock Systems, Latch & Link, Sprint, Drag Racing and more. If you are particular about your harnesses, call Simpson. We will make a custom set just for you and deliver quickly.



See Page 106 for custom belt order form.



CODE  
SB5.LUC.722BA

TYPE  
CAMLOCK STYLE 7-POINT  
W/T-BAR, 2" BLACK



CODE  
SB5.LUL.722BAT

TYPE  
LATCH & LINK STYLE 7-POINT  
DIRT STYLE W/T-BAR, 2"-3", BLACK



CODE  
SB6.LDC.722BAT

TYPE  
CAMLOCK NASCAR STYLE 7-POINT  
W/T-BAR, 2"-3", BLACK

# HARNESSES



CODE SB6.LUC.722BAF  
TYPE CAMLOCK FORMULA STYLE 7-POINT W/T-BAR, 2"-3", BLACK



CODE SB.100.5A  
TYPE QUARTER MIDGET STYLE LATCH & LINK, W/ALUMINUM ADJUSTERS, 2", BLACK

CODE SB.100.5  
TYPE QUARTER MIDGET STYLE W/STEEL ADJUSTERS, 2", BLACK



CODE SB.101.5A  
TYPE JUNIOR DRAGSTER STYLE CAMLOCK, W/ALUMINUM ADJUSTERS, 2", BLACK

CODE SB.101.5  
TYPE JUNIOR DRAGSTER STYLE CAMLOCK, W/STEEL ADJUSTERS, 2", BLACK



CODE SB5.51204  
TYPE LEFT SIDE RATCHET SYSTEM ALUMINUM ADJUSTERS DIRT TRACK STYLE, 2"-3", BLACK

## INTRODUCING SIMPSON BLACK



Simpson is offering the following SFI 16.1 models with black hardware

### 3" LATCH & LINK SYSTEM



CODE 29063BK1X TYPE 55" SEAT BELT PULL DOWN BOLT-IN



### 3" LEVER OR ROTARY CAMLOCK SYSTEMS



CODE 29110BKL1X TYPE LEVER  
29110BKR1X ROTARY



CODE 29110BKL3X TYPE LEVER  
29110BKR3X ROTARY



CODE 29110BKL2X TYPE LEVER  
29110BKR2X ROTARY



## 2" LEVER OR ROTARY CAMLOCK SYSTEMS WITH NEW CAMLOCK CLIP ADJUSTERS



CODE  
29400BKL1X LEVER  
29400BKR1X ROTARY



CODE  
29400BKL2X LEVER  
29400BKR2X ROTARY



CODE  
29400BKL3X LEVER  
29400BKR3X ROTARY



JOHN FORCE, NHRA 16-TIME FUNNY CAR CHAMPION



## ROTARY SERIES

### COLORS

Black, Platinum



### Rotary Series

CODE	TYPE
29118S0	PULL DOWN BOLT-IN, 6-PT, BLACK
29119S0	PULL UP BOLT-IN, 6-PT, BLACK
29218SP	PULL DOWN BOLT-IN, 6-PT, PLATINUM
29219SP	PULL UP BOLT-IN, 6-PT, PLATINUM



## ROTARY SERIES WITH 2" UPPERS

### Rotary Series with 2" Uppers

CODE	TYPE
29828S0	PULL DOWN BOLT-IN, 6-PT, BLACK
29829S0	PULL UP BOLT-IN, 6-PT, BLACK

## LATCH FX SERIES

### FEATURE

Can be made with 2" upper shoulder Harness for Head Restraints

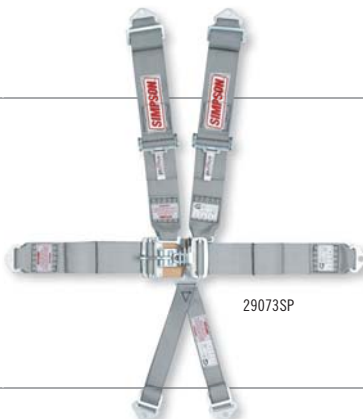

### Latch FX Series

CODE	TYPE
29073S0	PULL DOWN BOLT-IN, 6-PT, BLACK
29073SP	PULL DOWN BOLT-IN, 6-PT, PLATINUM

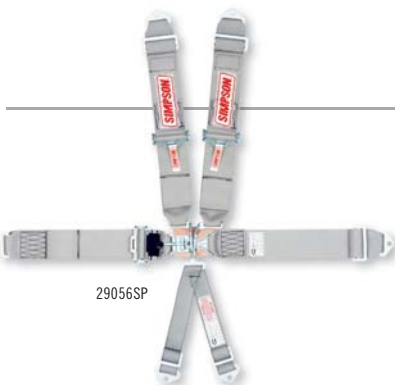

## LATCH & LINK SERIES

### FEATURE

Can be made with 2" upper shoulder Harness for Head Restraints



### Latch & Link Series

CODE	TYPE
29054S0	PULL DOWN BOLT-IN, 6-PT, BLACK
29055S0	PULL UP BOLT-IN, 6-PT, BLACK
29056SP	PULL DOWN BOLT-IN, 6-PT, PLATINUM
29057SP	PULL UP BOLT-IN, 6-PT, PLATINUM

## SPORT CAMLOCKS



**COLORS**  
Black, Blue, Red



29107 5-POINT

### Sport Camlocks

CODE	TYPE
29107	55" BOLT-IN SPORT CAMLOCK, 5-PT BLACK
29212	55" BOLT-IN SPORT CAMLOCK, 6-PT BLACK

## LEVER CAMLOCK TECHNOLOGY



Try our New Lever Camlock/Clip system redesigned to be 15% lighter. A unique internal release mechanism is engineered to eject belts clips quickly. Our belts clips are interchangeable with rotary camlock. These systems feature a sleek matte black finish.

**FEATURE**  
Can be made with 2" upper shoulder Harness for Head Restraints

**COLORS**  
Black, Blue, Red, Platinum



### Lever Camlock Technology

CODE	TYPE
29114	FORMULA CAR 6-WAY PULL UP, RESTRAINT BOLT-IN
29114P	UPGRADED TO PLATINUM SERIES
29102	62" FLOOR MOUNT SEAT BELT PULL UP, RESTRAINT BOLT-IN
29102P	UPGRADED TO PLATINUM SERIES
29104	62" SEAT BELT PULL UP, RESTRAINT BOLT-IN
29104P	UPGRADED TO PLATINUM SERIES
29108	55" SEAT BELT PULL DOWN, ROLL BAR V HARNESS BOLT-IN
29108P	UPGRADED TO PLATINUM SERIES
29110	55" SEAT BELT PULL DOWN, RESTRAINT BOLT-IN
29110P	UPGRADED TO PLATINUM SERIES
29112	55" WRAP AROUND SEAT BELT, PULL DOWN RESTRAINT
29112P	UPGRADED TO PLATINUM SERIES



29114P PLATINUM SERIES



29108



29110

## LATCH F/X



Compact integrated latch, link and adjuster reduces size by 30%. Drop-forged construction reduces weight by 30%. V-type or individual shoulder harnesses. Adjusters include anti-slip spring. No left side adjuster option available. Platinum Series also available.

### FEATURE

Can be made with 2" upper shoulder harness for Head Restraints

### COLORS

Black, Blue, Red, Platinum

### Latch F/X

CODE	TYPE
29072	62" WRAP AROUND SEAT BELT, PULL DOWN RESTRAINT WRAP AROUND
29072P	UPGRADED TO PLATINUM SERIES
29073	62" SEAT BELT PULL DOWN, RESTRAINT BOLT-IN
29073P	UPGRADED TO PLATINUM SERIES
29074	62" SEAT BELT PULL DOWN, ROLL BAR V HARNES BOLT-IN
29074P	UPGRADED TO PLATINUM SERIES

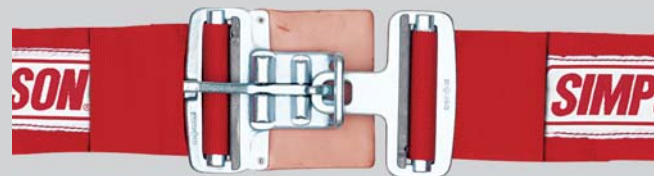
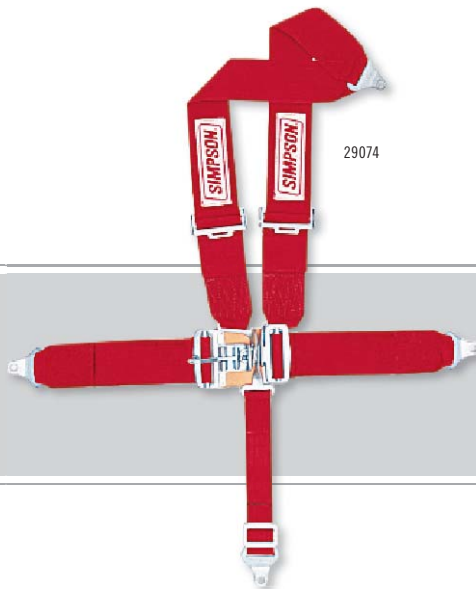

# HARNESSES

## SPORT LATCH & LINK

Features polyester construction for maximum protection. Belts ship as a wrap around system. Separate bolt in brackets included in the box. Sport Model features the S-Logo Simpson patch.

### COLORS

Black, Blue, Red



### Sport Latch & Link

CODE  
29043

TYPE  
55" BOLT-IN SPORT LATCH & LINK, 5-PT

## STD. LATCH & LINK

Drop-forged alloy steel with cadmium plating. Standard 3" military specification webbing on shoulder and lap belts with heat cut and sealed ends. Pull up or pull down adjusters. V-type or Individual shoulder harnesses. Adjusters include anti-slip springs. No left side adjuster option available. Floor-mount, bolt-in seat belts, or wrap around. Platinum Series also available.

### FEATURE

Can be made with 2" upper shoulder harness for Head Restraints

### COLORS

Black, Blue, Red, Platinum



29061



29063



29065



### STD. Latch & Link

CODE  
29061  
29061P  
29063  
29063P  
29064

29064P  
29065

29065P  
29066

29066P  
29075

29075P

TYPE  
62" SEAT BELT PULL UP RESTRAINT BOLT-IN  
UPGRADED TO PLATINUM SERIES  
55" SEAT BELT PULL DOWN, RESTRAINT BOLT-IN  
UPGRADED TO PLATINUM SERIES  
55" WRAP AROUND SEAT BELT PULL DOWN,  
RESTRAINT WRAP AROUND  
UPGRADED TO PLATINUM SERIES  
55" SEAT BELT PULL DOWN,  
ROLL BAR V HARNESS BOLT-IN  
UPGRADED TO PLATINUM SERIES  
SPRINT CAR BELT PULL DOWN,  
NO RIGHT SIDE ADJUSTER  
UPGRADED TO PLATINUM SERIES  
SPRINT CAR BELT PULL DOWN, NO RIGHT  
SIDE ADJUSTER W/SHORT SEW PATTERN  
UPGRADED TO PLATINUM SERIES





## RATCHET HARNESSES

For when the ride is especially rough and you want to keep those harnesses tightened down. Ratchet Harnesses are available in left side or right side, with Aluminum or Steel adjusters. These harnesses from our Platinum Plus line are manufactured at Simpson's North Carolina facility. In other words, like all Simpson belts, they are made in the USA!



### Ratchet Harnesses

CODE	TYPE
SB.51201	16.1 L&L W/ STEEL ADJUSTERS, RIGHT-SIDE RATCHET
SB.51202	16.1 L&L W/ AL ADJUSTERS, RIGHT-SIDE RATCHET
SB.51203	16.1 L&L W/ STEEL ADJUSTERS, LEFT-SIDE RATCHET
SB.51204	16.1 L&L W/ AL ADJUSTERS, LEFT-SIDE RATCHET



SB.51204



CALL FOR ADDITIONAL CONFIGURATIONS.

## JR. DRAGSTER

**COLORS**  
Black, Blue, Red



### Jr. Dragster

CODE	TYPE
35012	WRAP AROUND SEAT BELT, PULL UP ROLL BAR WRAP AROUND HARNESS



## QUARTER MIDGET

**COLORS**  
Black, Blue, Red



### Quarter Midget

CODE	TYPE
29025	WRAP AROUND SEAT BELT, PULL DOWN ROLL BAR WRAP AROUND HARNESS
29026	BOLT-IN SEAT BELT, PULL DOWN INDIVIDUAL HARNESS BOLT-IN



## 7 POINT DRAG CAMLOCK



Simpson Drag Restraints are SFI 16.1 Rated. Our belts are manufactured using polyester webbing for strength and durability. Bolt-in individual shoulder harness (18"). Lap belt has pull up adjustments on right and left side bolt-in. Formula style sub-belts with additional sub-belt to make 7th point. Nomex® covered.



### 7 Point Drag Camlock

CODE	TYPE
29115BK	FUNNY CAR RESTRAINT, BLACK
29115P	FUNNY CAR RESTRAINT, PLATINUM



29115BK



29116

## 5 AND 7 POINT DRAG CAMLOCK



Drag Racing 5-way restraint covered with Nomex®

**COLORS**  
Black, Blue, Red and Platinum upgrade

### 5 and 7 Point Drag Camlock

CODE	TYPE
29116	5-POINT RESTRAINT
29116P	5-POINT RESTRAINT, PLATINUM
29116M	7-POINT RESTRAINT, SINGLE SHOULDER
29110M	7-POINT RESTRAINT, INDIVIDUAL SHOULDERS



## OFFROAD D3 RESTRAINT

The Simpson D3 Buckle does what no other buckle system can do by providing the ease and convenience of a sewn-in harness without the shoulder straps being sewn to the lap belt. Its unique patented design eliminates the two shoulder strap links while still allowing the shoulder straps to be joined at the center of the buckle, truly emulating the V-Shape of a 5-Point Latch & Link System.

### FEATURES

- Patented D3 buckle
- Anti-slip adjusters
- Polyester webbing, anti-submarine belt
- Available in 3" x 3" and 2" x 2"
- D3, Not SFI Rated



### 3" x 3" D3 Restraint – Black Hardware

CODE	TYPE
3B33PIX	3" X 3" D3 BLACK HARDWARE, BOLT-IN, WITH PADS
3B33NIX	3" X 3" D3 BLACK HARDWARE, BOLT-IN, WITHOUT PADS
3F33PIX	3" X 3" D3 BLACK HARDWARE, FLOOR MOUNT, WITH PADS
3F33NIX	3" X 3" D3 BLACK HARDWARE, FLOOR MOUNT, WITHOUT PADS

### 3" x 3" D3 Restraint – Standard Plated Hardware

CODE	TYPE
3B33PI	3" X 3" D3 STD PLT HARDWARE, BOLT-IN, WITH PADS
3B33NI	3" X 3" D3 STD PLT HARDWARE, BOLT-IN, WITHOUT PADS
3F33PI	3" X 3" D3 STD PLT HARDWARE, FLOOR MOUNT, WITH PADS
3F33NI	3" X 3" D3 STD PLT HARDWARE, FLOOR MOUNT, WITHOUT PADS

### 2" x 2" D3 Restraint – Black Hardware

CODE	TYPE
3B22PIX	2" X 2" D3 BLACK HARDWARE, BOLT-IN, WITH PADS
3B22NIX	2" X 2" D3 BLACK HARDWARE, BOLT-IN, WITHOUT PADS
3F22PIX	2" X 2" D3 BLACK HARDWARE, FLOOR MOUNT, WITH PADS
3F22NIX	2" X 2" D3 BLACK HARDWARE, FLOOR MOUNT, WITHOUT PADS

### 2" x 2" D3 Restraint – Standard Plated Hardware

CODE	TYPE
3B22PI	2" X 2" D3 STD PLT HARDWARE, BOLT-IN, WITH PADS
3B22NI	2" X 2" D3 STD PLT HARDWARE, BOLT-IN, WITHOUT PADS
3F22PI	2" X 2" D3 STD PLT HARDWARE, FLOOR MOUNT, WITH PADS
3F22NI	2" X 2" D3 STD PLT HARDWARE, FLOOR MOUNT, WITHOUT PADS

## STERNUM BUCKLE



CODE:	TYPE:
PSTERNUMSTRAP	OFF-ROAD

## OFFROAD RECREATIONAL RESTRAINTS



### 3" X 3" LATCH & LINK

Not SFI Rated. Available in floormount.

#### COLORS

Black, Blue, Red, Platinum



#### 3" x 3" Latch & Link

CODE	TYPE
1B33PI	INDIVIDUAL, WITH PADS
1B33NI	INDIVIDUAL, NO PADS
1F33PI	INDIVIDUAL, FLOOR MOUNT, WITH PADS
1F33NI	INDIVIDUAL, FLOOR MOUNT, NO PADS

### 2" X 2" LATCH & LINK

Not SFI Rated. Available in floormount.

#### COLORS

Black, Blue, Red

#### 2" x 2" Latch & Link

CODE	TYPE
1B11PI	INDIVIDUAL, WITH PADS
1B11NI	INDIVIDUAL, NO PADS
1F11PI	INDIVIDUAL, FLOOR MOUNT, WITH PADS
1F11NI	INDIVIDUAL, FLOOR MOUNT, NO PADS

## OFFROAD RACING RESTRAINTS (NOT SHOWN)



### 3" X 3" LATCH & LINK

#### COLORS

Black, Blue, Red, Platinum

#### 3" x 3" Latch & Link

CODE	TYPE
29063-P	INDIVIDUAL, WITH PADS
29063	INDIVIDUAL, NO PADS
29263-P	INDIVIDUAL, FLOOR MOUNT, WITH PADS
29263	INDIVIDUAL, FLOOR MOUNT, NO PADS

### 2" X 2" LATCH & LINK

#### COLORS

Black, Blue, Red

#### 2" x 2" Latch & Link

CODE	TYPE
29023-P	INDIVIDUAL, WITH PADS
29023	INDIVIDUAL, NO PADS
29223-P	INDIVIDUAL, FLOOR MOUNT, WITH PADS
29223	INDIVIDUAL, FLOOR MOUNT, NO PADS



## SEATBELTS

### MOUNTING HARDWARE

Simpson offers 3 types of restraint mounting hardware: Bolt-in (left), Wrap Around (center), Floor Mount (right).



NOT SHOWN TO SCALE.  
FOR CONFIGURATION DEMONSTRATION ONLY.

CODE	TYPE
31022	BOLT-IN BRACKET, 2 EACH
31019	3" BAR SLIDE ADJUSTERS, 2 EACH
31020	FLOOR MOUNTING KIT, 2 EACH
31018	EYE BOLT KIT, EYEBOLT, NUT & WASHER

### LATCH FX SEATBELT

#### PULL DOWN ADJUSTMENT



CODE	TYPE
29030	62" FLOOR MOUNT, ADJUSTMENT TO 36"
29032	62" WRAP AROUND, ADJUSTMENT TO 32"
29034	62" BOLT IN, ADJUSTMENT TO 32"

COLORS: Black, Blue, Red, Platinum Series Upgrade Available

### LATCH AND LINK SEATBELT

#### PULL UP ADJUSTMENT



CODE	TYPE
29000	62" FLOOR MOUNT, ADJUSTMENT TO 36"
29002	62" WRAP AROUND, ADJUSTMENT TO 32"
29004	62" BOLT-IN, ADJUSTMENT TO 32"

COLORS: Black, Blue, Red, Platinum Series Upgrade Available

#### PULL DOWN ADJUSTMENT



CODE	TYPE
29020	55" FLOOR MOUNT
29022	WRAP AROUND, ADJUSTMENT TO 24"
29024	55" BOLT-IN

COLORS: Black, Blue, Red, Platinum Series Upgrade Available

### CAMLOCK SEATBELT

#### PULL UP ADJUSTMENT



CODE	TYPE
32000	62" FLOOR MOUNT
32002	62" WRAP AROUND
32004	62" BOLT-IN, ADJUSTMENT TO 36"

COLORS: Black, Blue, Red, Platinum Series Upgrade Available

#### PULL DOWN ADJUSTMENT



CODE	TYPE
32020	55" FLOOR MOUNT
32022	55" WRAP AROUND
32024	55" BOLT-IN

COLORS: Black, Blue, Red, Platinum Series Upgrade Available



## HARNESSES AND ANTI-SUB BELTS

### DUAL ANTI-SUB BELTS

Semi-adjustable. Measures 27" per side. Bolt-in installation. Fits CamLock or Latch Type buckle.



CODE  
**34014**  
**31014**

TYPE  
**CAMLOCK**  
**LATCH TYPE**

*COLORS: Black, Blue, Red, Platinum Series Upgrade Available*

### ROLLBAR MOUNT

Compatible with SFI 38.1 Head and Neck restraint. 3" V-type shoulder harness attaches to any belt. V belt length from bolt-in mounting bracket to the buckle has adjustable length of 24 to 33 inches.



CODE  
**33005**  
**30005**

TYPE  
**CAMLOCK**  
**LATCH TYPE**

*COLORS: Black, Blue, Red, Platinum Series Upgrade Available*

### ANTI-SUBMARINE BELTS



CODE  
**34012**  
**31012**  
**34013**  
**31013**

TYPE  
**CAMLOCK BOLT-IN**  
**LATCH TYPE BOLT-IN**  
**CAMLOCK FLOOR MT.**  
**LATCH TYPE FLOOR MT.**

*COLORS: Black, Blue, Red, Platinum Series Upgrade Available*

### SHOULDER HARNESS HEAD & NECK RESTRAINT COMPATIBLE

Compatible with SFI 38.1 Head and Neck restraint. Individual shoulder harnesses. 48" length adjusts down to 24". Shoulder harness 2" (shown).



CODE  
**33010**  
**30010**

TYPE  
**CAMLOCK**  
**LATCH TYPE**

*COLORS: Black, Blue, Red, Platinum Series Upgrade Available*

Semi-adjustable  
27" long  
Adjustable Pull-up  
Bolt-in mounting



CODE  
**34015**  
**31015**

TYPE  
**CAMLOCK**  
**LATCH TYPE**

*COLORS: Black, Blue, Red, Platinum Series Upgrade Available*

### HEAD AND NECK RESTRAINT DUAL HARNESS

CODE  
**33011**  
**30011**

TYPE  
**CAMLOCK DUAL**  
**LATCH & LINK, DUAL WRAP AROUND**

*COLORS: Black, Blue, Red, Platinum Series Upgrade Available*

### SHOULDER HARNESS

Individual shoulder harnesses. 48" long and adjust down to 24". Bolt-in or wrap around style.



CODE  
**33004**  
**30004**

TYPE  
**CAMLOCK**  
**LATCH TYPE BOLT-IN**

*COLORS: Black, Blue, Red, Platinum Series Upgrade Available*

### STERNUM BUCKLE

Holds shoulder harness together. For CamLock or standard Latch & Link seat belts. NOT SOLD SEPARATELY. Can only be added at time of belt purchase. Order harness part number and add Sternum Protector.



CODE  
**PSTERNUMSTRAP**

### FLOOR MOUNT INDIVIDUAL HARNESS 75" (Not Shown)

CODE  
**33009**  
**30009**

TYPE  
**CAMLOCK**  
**LATCH TYPE**

*COLORS: Black, Blue, Red, Platinum Series Upgrade Available*

## TIE DOWNS AND RESTRAINTS

### HELMET RESTRAINTS

Fatigue-reducing helmet strap  
Quick attachment and adjustment  
Durable steel hardware, helmet  
"D-ring" installation



CODE                    TYPE  
**36007**                    **HELMET RESTRAINT**

COLORS: Black, Blue, Red

### RATCHET TIEDOWNS

High-strength ratchet tie-downs secure racing vehicle to trailer or transporter  
2" polyester webbing featuring a ratcheting buckle with integral hook and snap hook  
at opposite end  
Convenient and easy to use, these tie-downs go on and off with a few flicks of the wrist  
Sold in pairs, each piece 8' long



CODE                    TYPE  
**35007**                    **RATCHET TIE DOWN (PAIR)**

COLORS: Black, Blue, Red

### ROLLBAR PADDING

Open Cell Urethane padding comes in 36" sections  
"C" shaped to fit 1 5/8" to 2" tubing  
WILL NOT DRIP OR MELT  
Meets SFI 45.1  
Impact test proven effective



CODE                    TYPE  
**36008**                    **SFI 45.1 EMBOSSED IN PADDING**

COLOR: Black

### SHIFT BOOT COVER

Simpson leads the way in racing safety once again with our reinforced shift boot cover,  
equipped with an innovative top seal Kevlar strap and D-Ring fastener designed to  
control the spread of a fire from underneath the car into the cockpit area.

SFI 48.1 approved  
Made with Nomex®  
Reverse Stitching Nomex® thread seam  
Kevlar interior for added protection  
Base: 7.25" x 6.25"



CODE                    TYPE  
**36012**                    **SHIFT BOOT COVER**

Color: Black only

### NOMEX® HARNESSES PADS

Attaches with speedfit to shoulder harness or lap belt  
Tighten down your belts in comfort



CODE                    TYPE  
**230210**                    **HARNESSES PADS (PAIR)**

COLORS: Black, Blue, Red

### AXLE RATCHET TIE DOWN W/D-RING

8' long tie down provides additional security via axle or rear-end  
2" polyester webbing features a ratcheting buckle with integral hook and sail hook  
that fastens into a D-ring  
Sold individually



CODE                    TYPE  
**35009**                    **AXLE RATCHET TIE DOWN (EACH)**

COLORS: Black, Blue, Red

### AXLE STRAPS

Ties down racing vehicle via axle or wrap around the frame  
24" long with 2" webbing  
D-rings on both ends



CODE                    TYPE  
**35010**                    **AXLE STRAP (EACH)**  
**35008**                    **15' TOW STRAP (EACH)**  
**35011**                    **LIMITER STRAP (EACH)**

COLORS: Black, Blue, Red

### ARM RESTRAINTS

Meets SFI 3.3.  
A must for Sprint, Midget  
and Off-Road racing.  
Features padded arm bands  
and steel hardware.  
Easy release allows quick entry and exit from driver's compartment.



CODE                    TYPE  
**36000**                    **ARM RESTRAINT W/ INDIVIDUAL STRAPS**  
**36001**                    **ARM RESTRAINTS W/Y STRAPS**  
**J3600**                    **JR. ARM RESTRAINT W/ INDIVIDUAL STRAPS**  
AVAILABLE WITH "Y" STRAPS AS CUSTOM ORDER  
COLORS: Black, Blue, Red

**54018**                    **INDIVIDUAL REPLACEMENT STRAPS**  
**FOR BUILT-IN ARM RESTRAINT**

**AR.QTM**                    **JR. ARM RESTRAINTS (VELCRO)**  
**AR.ADU**                    **ADULT ARM RESTRAINTS (VELCRO), BLACK ONLY**



## NETS AND ACCESSORIES

### LEFT SIDE MOUNT CAGE NET

SFI 37.1 approved. Webbing tensile strength is 6,000 lbs. Fits up to 58" between "A" post and roll cage behind seat. Wraps around seat to support Head rest and shoulder. Helps keep driver in proper position and provides extra barrier behind window net.



CODE  
**36016**

TYPE  
**LEFT SIDE MOUNT**

COLOR: Black

### RIGHT SIDE MOUNT CAGE NET

SFI 37.1 approved. Webbing tensile strength is 6,000 lbs. Fits up to 58" between dash bar and roll cage behind seat. Wraps around seat to support Head rest and shoulder. Helps keep driver in proper position during crash.

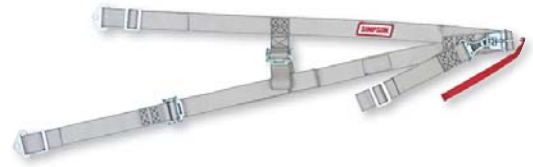

CODE  
**36015**

TYPE  
**RIGHT SIDE MOUNT**

COLOR: Platinum

### SPRINT/MIDGET NET

Meets SFI 37.1. Window nets for Sprints, Midgets and Quarter Midgets. 1" webbing with quick release buckle.



CODE  
**36005**  
**J36005**  
**36006**

TYPE  
**SPRINT**  
**QUARTER MIDGET**  
**CHAMP CAR**

COLORS: Black, Blue, Red

### C5R DRIVER NET

Our original red handle nets adapt to all makes and models of race cars. SFI 37.1 Approved. Available in Kevlar or Polyester. Quick Release Design. The CR5s special design keeps it out of the field of vision while providing side and angular impact protection.



CODE  
**DN.C5R.RK**  
**DN.C5R.LK**  
**DN.C5R.RP**  
**DN.C5R.LP**

TYPE  
**RIGHT SIDE KEVLAR**  
**LEFT SIDE KEVLAR**  
**RIGHT SIDE POLY**  
**LEFT SIDE POLY**

### GRAND AM KEVLAR NET



CODE  
**DN.GRD.RK**  
**DN.GRD.LK**

TYPE  
**RIGHT SIDE KEVLAR**  
**LEFT SIDE KEVLAR**

### SPRINT CAR NET



CODE  
**DN.SPR.RK**  
**DN.SPR.LK**  
**DN.SPR.RP**  
**DN.SPR.LP**

TYPE  
**RIGHT SIDE KEVLAR**  
**LEFT SIDE KEVLAR**  
**RIGHT SIDE POLY**  
**LEFT SIDE POLY**



## NETS AND ACCESSORIES

### KART BRACE

Dual foam layers provide a protective inner core with a comfortable outer shell and an abrasion-resistant fabric lining. Rigid SFI 45.2 impact rated foam reduces neck flexion and head rotation during impact.



CODE  
**KARTBRACE. LW**

TYPE  
**ADULT AND YOUTH SIZE AVAILABLE**

COLOR: *Black*

### PADDED NECK SUPPORT

SFI tag included, SFI 3.3 approved. Reduces Neck fatigue for any racer. Removable knit Nomex® sleeve. One size with adjustable speedfit fasteners (*can be custom fit*).



CODE  
**23022**

TYPE  
**RED**

**23022**

**BLUE**

**23022**

**BLACK**

COLORS: *Black, Blue, Red*

### PADDED NECK COLLAR

Head and Neck restraint compatible.  
SFI 45.2 Padding



CODE  
**NC.CHD.YTH**  
**NC.SML**  
**NC.MED**  
**NC.LRG**

COLOR: *Black*

### WINDOW NET

Standard, NASCAR or Custom  
Meets SFI 27.1. Stock Car type and square window nets for full-bodied cars. Stock Car type is 16" x 27" trapezoid with 1" webbing.

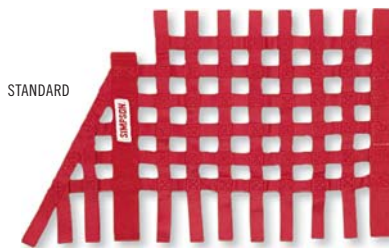

CODE  
**36002**

TYPE  
**18" X 24" RECTANGLE**

**36003**

**24" X 24" SQUARE**

**36004**

**16" X 27" TRAPEZOID**

**36013**

**CUSTOM NET SEND TEMPLATE**

COLORS: *Black, Blue, Red*

NASCAR,  
OFFERED IN BLACK ONLY



CODE  
**NASCAR**

TYPE  
**NASCAR NET, BLACK ONLY**

### CHIN STRAPS



CODE  
**RH.DCS**  
**DRC.SS**  
**DRC.CS**

TYPE  
**DOUBLE CHIN STRAP "W"**  
**SINGLE CHIN STRAP**  
**CENTERING CHIN STRAP**

### OFF-ROAD NECK COLLAR

WITH OR  
WITHOUT FLANGE



CODE  
**NC.OR**  
**NC.ORF**

TYPE  
**OFF-ROAD**  
**OFF ROAD W/FLANGE (AS SHOWN)**

## 12' CROSSFORM DRAG CHUTE



Designed for Funny Cars and Dragsters. Handmade Crossform design for outstanding performance from 200 to 300+ mph. Complete with aluminized pack and pilot chute.

**COLORS**

Black, Blue, Red, Golden Yellow



CODE:  
42060

TYPE:  
CROSSFORM DRAG CHUTE

CALL FOR QUOTE TO ADD CUSTOM LETTERS AND/OR LOGO.

## 10' SKY JACKER DRAG CHUTE



Handmade Crossform design delivers reliable and durable performance for all cars up to 200 mph. Complete with black nylon pack and pilot chute.

**COLORS**

Black, Blue, Red, Golden Yellow. Custom colors available.



CODE:  
42020

TYPE:  
SKY JACKER DRAG CHUTE

CALL FOR QUOTE TO ADD CUSTOM LETTERS AND/OR LOGO.

## 14' PROFESSIONAL SERIES



Our largest 14' parachute canopy. All Kevlar chute and shroud line construction. 20% lighter than traditional nylon chute. Kevlar translates to increased speed and a safer racing environment. Increased fire protection. Handmade in the USA, cross form design for top performance at speeds of 300+ mph. Ships complete with pack and pilot chute.



14' Professional Series

CODE      TYPE  
42055      14' KEVLAR CHUTE WITH KEVLAR® SHROUD LINES  
*Color: Yellow Only*

42050      14' PREMIUM NYLON CHUTE WITH KEVLAR® SHROUD LINES  
*Colors: Black, Blue, Red and Golden Yellow*

CALL FOR QUOTE TO ADD CUSTOM LETTERS AND/OR LOGO.

Kevlar® Parachutes are 20% Lighter

## 8 FT. OUTLAW SKY JACKER DRAG CHUTE



Made in the USA. 4 Lightweight Kevlar Shroud Lines make the Outlaw chute the number 1 choice for drag racers looking to reduce their weight load. Professional series stopping power, quality construction. Handmade crossform chute delivers reliable performance for cars up to 200 mph. Ships with pack and pilot chute.



### COLORS

Black, Red, Blue, Golden Yellow

### 8 ft. Outlaw Sky Jacker Drag Chute

CODE	TYPE
42038	8' DRAG CHUTE FEATURING KEVLAR SHROUD LINE CONSTRUCTION

CALL FOR QUOTE TO ADD CUSTOM LETTERS AND/OR LOGO.

## AIR BOSS PARACHUTE 10 FT.



### COLORS

Black, Blue, Red, Golden Yellow



### FEATURES

Pneumatic Launcher Style  
 Designed for applications where a launcher style chute is necessary  
 Canopy Size: Order 8' or 10' chute  
 Four Kevlar lines for added protection  
 Chutes manufactured in the USA  
 Quality craftsmanship  
 Team and Sponsor logos can be added (*call for pricing*)  
 Simpson race day service and support still going strong

### Air Boss Parachute 10 Ft.

CODE	TYPE
42040	10' CHUTE
42041	10' CHUTE/LAUNCHER
42042	10' DUAL AIR BOSS, CHUTE/LAUNCHER
42043	10' LAUNCHER SYSTEM
42044	10' DUAL LAUNCHER SYSTEM
42045	BLACK NOMEX® CHUTE PACK, 10' AIR BOSS
42046	BLACK PILOT BAG, 10' AIR BOSS

## AIR BOSS PARACHUTE 8 FT.

### Air Boss Parachute 8 Ft.

CODE	TYPE
42030	8' CHUTE
42031	8' CHUTE / LAUNCHER
42032	8' DUAL AIR BOSS, CHUTE / LAUNCHER
42033	8' LAUNCHER SYSTEM
42034	8' DUAL LAUNCHER SYSTEM
42035	BLACK NYLON CHUTE PACK, 8' AIR BOSS
42036	BLACK PILOT BAG, 8' AIR BOSS

## MINI DRAGSTER PARACHUTE AND CHUTE ACCESSORIES (NOT SHOWN)



## CHUTE FLAG TWO SIDED

CODE:  
CHUTEFLAG

Simpson Branded. Two Sided Chute Flag. Simpson Red.

### Mini Dragster Parachute and Chute Accessories

CODE	TYPE
42082	MINI DRAGSTER CHUTE
42085	PILOT CHUTE (ALL MODELS)
42087	CROSSFORM PACK
42086	SKY JACKER PACK

**OFF-ROAD SEATS**

**FASTEN  
YOUR SEATS**

## NEW **UTV** SPORT VINTAGE STYLE SUIT



UTV Suit features our popular 3 stripe retro styling  
 One-piece suit meets and exceeds SFI 3.2A/1 and SFI 5 3.2/5 requirements  
 Black Ankle and Wrist Cuffs  
 Standard Shoulder Epaulets  
 Red, Orange and Yellow racing stripes on driving suit arms

### SIZES

Small – XXLarge, 15% upcharge for XXL

### COLOR

Black Only

CODE: **U3** SIZE: **SFI 3.2/1 RATED**

CODE: **U4** SIZE: **SFI 3.2/5 RATED**



## VORTEX

The Vortex seat provides high containment while still allowing for easy entry and exit with its cutaway lower bolster design. It is designed to work with the factory slider without raising the seat height. The Vortex's traditional tube-style frame is mated to a laser cut seat base which utilizes a variety of different modular mounting rails. Optional seat heaters and adjustable lumbar supports are available.

The Vortex model is available in 3 sizes:

1. Standard size
2. Wide Body )
3. Short Cushion (the base is 2" shorter front to back)



BLACK/RED



### Vortex

CODE	TYPE
101-305	VORTEX BLACK/CHARCOAL
101-306	VORTEX BLACK/RED
101-308	VORTEX BLACK/ORANGE
101-317	VORTEX BLACK/LT BLUE
101-CUS	VORTEX CUSTOM

\*THE VORTEX MODULAR DESIGN FITS SEVERAL VEHICLES. MOUNTS ARE NOT INCLUDED AND MUST BE PURCHASED SEPARATELY. SEE PAGE 99.

SEAT MEASUREMENTS ARE LOCATED ON PAGE 100



BLACK/LT BLUE



BLACK/CHARCOAL



BLACK/ORANGE

## RALLY

The Rally is another take on our very popular Vortex seat. It sports a very classy race-inspired color scheme with clean lines and contrasting colors. All Vortex options and accessories are available.

The Rally model is available in 3 sizes:

1. Standard size
2. Wide Body
3. Short Cushion (the base is 2" shorter front to back)



BLACK/ORANGE



### Rally

CODE	TYPE
104-305	VORTEX RALLY BLACK/CHARCOAL
104-306	VORTEX RALLY BLACK/RED
104-308	VORTEX RALLY BLACK/ORANGE
104-317	VORTEX RALLY BLACK/LT BLUE
104-CUS	VORTEX RALLY CUSTOM

SEAT MEASUREMENTS ARE LOCATED ON PAGE 100



BLACK/LT BLUE



BLACK/RED



BLACK/CHARCOAL



## VORTEX REAR BENCH

The Vortex rear bench is completely bolt-in. It does not require any cutting or permanent modifications to install and utilizes a laser cut panel to replace the factory plastic console. The rear bench matches the styling of the new Vortex and can be ordered in colors that complement the factory front seat for those who do not want to replace the OEM front seats. Optional seat heaters and adjustable lumbar supports are available.



### Vortex Rear Bench

CODE	TYPE
116-510-305	VORTEX REAR BENCH BLACK/CHARCOAL
116-510-306	VORTEX REAR BENCH BLACK/RED
116-510-307	VORTEX REAR BENCH BLACK/BLUE
116-510-308	VORTEX REAR BENCH BLACK/ORANGE
116-510-309	VORTEX REAR BENCH BLACK/SILVER
116-510-316	VORTEX REAR BENCH BLACK/WHITE
116-510-317	VORTEX REAR BENCH BLACK/LT BLUE
116-510-CUS	VORTEX REAR BENCH CUSTOM

\*ABOVE PART NUMBERS FIT XP 4 1000, XP 4 TURBO, 2015 + XP 4 900

\*\*ALSO AVAILABLE FOR 2010-2014 RZR 4 800/900

SEAT MEASUREMENTS ARE LOCATED ON PAGE 100

## PRO V2

### ALL NEW RE-ENGINEERED DESIGN FOR IMPROVED PERFORMANCE

The Pro V2 features a removable bottom cushion for added comfort, containment and ease of cleaning. The 2018 Pro V2 features a wider thigh area and a roomier bottom cushion and is 3" higher for an all-around improved fit. The Pro V2 uses the traditional off-road 3/16" four tab mounting design that is 14" across and 18" front to back. Optional seat heaters and adjustable lumbar support are available.



CUSTOM COLORS



### Pro V2 (Universal Tab Mounted)

CODE	TYPE
502-107-101	PRO V2 ALL MATTE BLACK
502-107-500	PRO V2 XCEL BLACK CLOTH/MATTE BLACK
502-107-105	PRO V2 MATTE BLACK/CARBON FIBER BLACK
502-107-106	PRO V2 MATTE BLACK/CARBON FIBER BLACK/RED
502-107-107	PRO V2 MATTE BLACK/CARBON FIBER BLACK/BLUE
502-107-108	PRO V2 MATTE BLACK/CARBON FIBER BLACK/ORANGE
502-107-109	PRO V2 MATTE BLACK/CARBON FIBER BLACK/CARBON FIBER SILVER
502-107-111	PRO V2 MATTE BLACK/CARBON FIBER BLACK/KAWASAKI GREEN
502-107-CUS	PRO V2 CUSTOM

SEAT MEASUREMENTS ARE LOCATED ON PAGE 100

## TS-R

The TS-R offers the highest level of shoulder and thigh containment of any of our suspension seats and its styling is second to none. Its open side bolster design allows for easy lap belt adjustability. The TS-R is available in two mounting configurations, 14" x 18" tab mount designed for sand cars, race vehicles, buggies, etc. It is also available in a direct bolt-in for the Polaris RZR XP 1000 models. It utilizes the factory slider while keeping the rider height the same as stock. It is available in several standard colors ways and can be custom ordered to enhance your ride.



### TS-R (Universal Tab Mounted)

CODE	TYPE
500-108-149	TS-R BLACK/CHARCOAL
500-108-150	TS-R BLACK/RED
500-108-151	TS-R BLACK/BLUE
500-108-152	TS-R BLACK/ORANGE
500-108-153	TS-R BLACK/SILVER
500-108-154	TS-R BLACK/WHITE
500-108-CUS	TS-R CUSTOM

\*OPTIONAL SEAT HEATERS AND ADJUSTABLE LUMBAR SUPPORTS ARE AVAILABLE.  
 \*\*CONTACT US REGARDING XP 1000 FITMENT.

SEAT MEASUREMENTS ARE LOCATED ON PAGE 100

CUSTOM COLORS



BLACK/CHARCOAL



## 170 AGGRESSOR

### ALL NEW RE-ENGINEERED DESIGN FOR IMPROVED PERFORMANCE

The RZR 170 has been totally re-engineered to provide superior containment in conjunction with a 5 point harness and is a direct bolt-in replacement for the stock seats. It is available in three different color options or it can be customized to order in a wide variety of colors and materials to complement your car.



### 170 Aggressor

CODE	TYPE
110-305	170 AGGRESSOR M BLACK/GREY/WHITE/C FIBER
110-306	170 AGGRESSOR M BLACK/RED/WHITE/C FIBER
110-317	170 AGGRESSOR M BLACK/LT BLUE/WHITE/C FIBER
110-CUS	170 AGGRESSOR CUSTOM

\*MOUNTS ARE NOT INCLUDED AND MUST BE PURCHASED SEPARATELY. SEE PAGE 99.

SEAT MEASUREMENTS ARE LOCATED ON PAGE 100

BLACK/LT BLUE/WHITE



BLACK/GREY/WHITE





## PRO SPORT

The all new Pro Sport was developed together with SDR Motorsports and engineered for superior fit, function, comfort and style all while keeping its mounting position as low as possible in the vehicle. The Pro Sport is 2" wider than our standard Vortex in key areas with extra broad shoulders for the ultimate comfort and containment. Its base is made up of our laser-cut universal pan design making it ideal for UTVs, Buggies, Jeeps and most all off-road vehicles. Optional seat heaters and adjustable lumbar supports are available.



### Pro Sport

CODE	TYPE
106-305	PRO SPORT BLK/CHAR/GREY
106-306	PRO SPORT BLK/RED/GREY
106-308	PRO SPORT BLK/ORG/GREY
106-317	PRO SPORT BLK/LT BLUE/GREY
106-CUS	PRO SPORT CUSTOM

\*THE PRO SPORT MODULAR DESIGN FITS SEVERAL VEHICLES. MOUNTS ARE NOT INCLUDED AND MUST BE PURCHASED SEPARATELY. SEE PAGE 99.

SEAT MEASUREMENTS ARE LOCATED ON PAGE 100

BLACK/LT BLUE/GREY



BLACK/RED/GREY



BLACK/ORANGE/GREY



BLACK/CHARCOAL/GREY

## REVOLVER

The Revolver seat provides extra room for larger riders with its low side bolsters. It has a contoured removable bottom cushion that helps keep the occupant in place. The Revolver is also available with a universal 14" x 18" tab mount design for buggies, sand cars, etc.



### Revolver – Polaris RZR 570/800/900 (2014 and earlier)

CODE	TYPE
101-150-101	REVOLVER – RZR 570/800/900 ALL MATTE BLACK
101-150-102	REVOLVER – RZR 570/800/900 CARBON FIBER BLACK
101-150-105	REVOLVER – RZR 570/800/900 MATTE BLACK/CF BLACK
101-150-106	REVOLVER – RZR 570/800/900 MATTE BLACK/CF BLACK/RED
101-150-107	REVOLVER – RZR 570/800/900 MATTE BLACK/CF BLACK/BLUE
101-150-108	REVOLVER – RZR 570/800/900 MATTE BLACK/CF BLACK/ORANGE
101-150-109	REVOLVER – RZR 570/800/900 MATTE BLACK/CF BLACK/CF SILVER
101-150-110	REVOLVER – RZR 570/800/900 MATTE BLACK/CF BLACK/CF WHITE
101-150-CUS	REVOLVER – RZR 570/800/900 CUSTOM

SEAT MEASUREMENTS ARE LOCATED ON PAGE 100

## XL-R

The XL-R was designed with the Jeep daily driver in mind with its reclining backrest and easy exit/entry bolster design. The reclining function allows you to fine-tune the comfort level and provides easy backseat access. Like all of our seats, the XL-R is a suspension seat and is built with the highest quality materials. The XL-R adds comfort, safety and style to any ride.



CUSTOM COLORS



### XL-R (Reclining Universal Tab Mounted)

CODE	TYPE
505-108-101	XL-R ALL MATTE BLACK
505-108-500	XL-R XCEL BLACK CLOTH/MATTE BLACK
505-108-105	XL-R MATTE BLACK/CARBON FIBER BLACK
505-108-106	XL-R MATTE BLACK/CARBON FIBER BLACK/RED
505-108-107	XL-R MATTE BLACK/CARBON FIBER BLACK/BLUE
505-108-108	XL-R MATTE BLACK/CARBON FIBER BLACK/ORANGE
505-108-109	XL-R MATTE BLACK/CARBON FIBER BLACK/ CARBON FIBER SILVER
505-108-CUS	XL-R CUSTOM

SEAT MEASUREMENTS ARE LOCATED ON PAGE 100

## D3

The Simpson D3 buckle does what no other buckle system can. It provides the ease and convenience of a sewn-in harness without the shoulder straps being sewn to the lap belt. Its unique patented design eliminates the two shoulder strap links while still allowing the shoulder straps to be joined at the center of the buckle, truly emulating the "V" shape of a 5 point latch and link.

\*To order a D3 harness with cadmium plated hardware, remove the "X" from the end of the part number. Shoulder speed adjusters are not available with cadmium plating.



ALSO AVAILABLE IN STANDARD LATCH AND LINK  
CALL FOR PRICING



### D3

CODE	TYPE
3B22PIKX	2" BLACK WITH PADS
3B22PIRX	2" RED WITH PADS
3B22PIBX	2" BLUE WITH PADS
3B33PIKX	3" BLACK WITH PADS
3B33PIRX	3" RED WITH PADS
3B33PIBX	3" BLUE WITH PADS
3B22NIKX	2" BLACK NO PADS
3B22NIRX	2" RED NO PADS
3B22NIBX	2" BLUE NO PADS
3B33NIKX	3" BLACK NO PADS
3B33NIRX	3" RED NO PADS
3B33NIBX	3" BLUE NO PADS

## VORTEX MOUNTS

### POLARIS RZR



#115

### YAMAHA YXZ



#202P

#202D

### CAN AM X3



#303

CODE	TYPE
115	POLARIS RZR 570/800/900/1000/TURBO (INCLUDING FRONT OF ALL RZR 4), GENERAL, ACE
255	ARCTIC CAT WILDCAT 1000 H.O./TRAIL MOUNTS
260	ARCTIC CAT X MOUNTS INCLUDING FRONT OF WILDCAT 4
202	YAMAHA YXZ "DRIVE 202D" "PASSENGER 202P"
302D	CAN AM COMMANDER/MAVERICK "DRIVER" INCLUDING FRONT OF MAX
302P	CAN AM COMMANDER/MAVERICK "PASSENGER" INCLUDING FRONT OF MAX
303	CAN AM X3 FRONT MOUNT
110	POLARIS 170 SEAT MOUNT

## SEAT OPTIONS

### YXZ DOOR LATCH PADS



#2021

### BAGS



#BAGCHS  
GOGGLE BAG (CARBON FIBER BLACK VINYL W/WELCRO LOOPS FOR 1-3/4" TUBING)

### WINDOW NETS



#36013M  
CUSTOM MESH NET, SEND TEMPLATE CALL FOR QUOTE

HEATER  
LUMBAR  
POCKETFRONT  
POCKETREAR  
POCKETHYDRATION  
EXTRAWIDE  
HEADREST

TYPE  
SEAT HEATER  
ADJUSTABLE LUMBAR  
FRONT POCKET  
REAR POCKET  
HYDRATION PACK POCKET  
EXTRA WIDE  
ADD HEADRESTS TO OFF-ROAD BENCH

## JEEP MOUNTS (NOT SHOWN)

CODE	TYPE
JK001	JK SEAT ADAPTER
JKR02	JK UNLIMITED REAR SEAT MOUNT
TJ0306	TJ 03-06 SEAT ADAPTER
TJR801	TJ REAR BENCH MOUNT
TJ9702	TJ 97-02 SEAT ADAPTER
YJ001	YJ SEAT ADAPTER
YJR801	YJ REAR BENCH MOUNT

## YXZ LAP BELT MOUNTS



CODE	TYPE
2022	YXZ LAP BELT MOUNTS

## POLARIS LAP BELT MOUNTS



POLARIS OWNERS –  
ARE YOUR LAP  
BELTS TWISTED?



CODE	TYPE
2030	POLARIS LAP BELT MOUNTS

## SEAT MEASUREMENTS



- A Base Width
- B Base Length
- C Cushion Width Front
- D Cushion Width Rear
- E Cushion Length
- F Overall Width Thigh
- G Overall Width Waist
- H Overall Width Shoulder
- I Back Height
- J Overall Height
- K Tabs/Rails
- L Bolster Height
- M Shoulder Slots

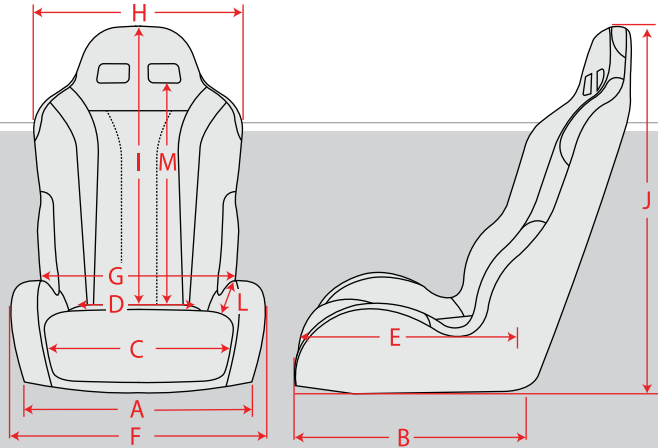

### VORTEX

A Base Width	17"
B Base Length	21"
C Cushion Width Front	15"
D Cushion Width Rear	11"
E Cushion Length	20"
F Overall Width Thigh	20"
G Overall Width Waist	20"
H Overall Width Shoulder	21"
I Back Height	29"
J Overall Height	32.5"
K Tabs	Universal
L Bolster Height	4"
M Shoulder Slots	24"

Weight 23lb  
Angle 75

### WIDE BODY

A Base Width	18.5"
B Base Length	22"
C Cushion Width Front	17"
D Cushion Width Rear	11"
E Cushion Length	20.5"
F Overall Width Thigh	22"
G Overall Width Waist	20"
H Overall Width Shoulder	23"
I Back Height	29"
J Overall Height	32.5"
K Tabs	Universal
L Bolster Height	2"
M Shoulder Slots	24"

Weight 24lb  
Angle 75

### REAR

A Base Width	17"
B Base Length	19"
C Cushion Width Front	15"
D Cushion Width Rear	11"
E Cushion Length	17"
F Overall Width Thigh	20"
G Overall Width Waist	20"
H Overall Width Shoulder	21.5"
I Back Height	29"
J Overall Height	32.5"
K Tabs	Universal
L Bolster Height	4"
M Shoulder Slots	24"

Weight 19.5lb  
Angle 75

### BENCH

A Base Width	43.5"
B Base Length	19"
C Cushion Width Front	38.5"
D Cushion Width Rear	37"
E Cushion Length	18"
F Overall Width Thigh	44.75"
G Overall Width Waist	44"
H Overall Width Shoulder	45.5"
I Back Height	29"
J Overall Height	34.25"
K Tabs	10.875"
L Bolster Height	4.5"
M Shoulder Slots	23"

Weight 48lb  
Angle 75

### PRO SPORT

A Base Width	19.5"
B Base Length	22"
C Cushion Width Front	17"
D Cushion Width Rear	11"
E Cushion Length	20.5"
F Overall Width Thigh	23"
G Overall Width Waist	20"
H Overall Width Shoulder	23"
I Back Height	32.5"
J Overall Height	34"
K Tabs	Universal
L Bolster Height	3"
M Shoulder Slots	23"

Weight 24lb  
Angle 75

### 170 AGGRESSOR

A Base Width	16"
B Base Length	17.5"
C Cushion Width Front	12.5"
D Cushion Width Rear	10"
E Cushion Length	15"
F Overall Width Thigh	17.5"
G Overall Width Waist	15.5"
H Overall Width Shoulder	19.5"
I Back Height	24"
J Overall Height	26"
K Tabs	Universal
L Bolster Height	2.5"
M Shoulder Slots	17.5"

Weight 16lb  
Angle 73

### TSR

A Base Width	15.5"
B Base Length	21.5"
C Cushion Width Front	15"
D Cushion Width Rear	11"
E Cushion Length	21"
F Overall Width Thigh	22.5"
G Overall Width Waist	22.25"
H Overall Width Shoulder	25"
I Back Height	31"
J Overall Height	34.5"
K Tabs	14" x 18"
L Bolster Height	5.25"
M Shoulder Slots	24"

Weight 27lb  
Angle 75

### PRO V2

A Base Width	15.5"
B Base Length	21.5"
C Cushion Width Front	14.5"
D Cushion Width Rear	11.5"
E Cushion Length	21"
F Overall Width Thigh	20.75"
G Overall Width Waist	21.75"
H Overall Width Shoulder	23"
I Back Height	30"
J Overall Height	34"
K Tabs	14" x 18"
L Bolster Height	8.5"
M Shoulder Slots	23"

Weight 22lb  
Angle 75

### XL-R

A Base Width	19"
B Base Length	22"
C Cushion Width Front	14"
D Cushion Width Rear	11.5"
E Cushion Length	19"
F Overall Width Thigh	21.25"
G Overall Width Waist	19.75"
H Overall Width Shoulder	21.5"
I Back Height	29.5"
J Overall Height	34"
K Tabs	14" x 18"
L Bolster Height	2"
M Shoulder Slots	23"

Weight 28lb  
Angle Adjustable

### REVOLVER

A Base Width	18.25"
B Base Length	20.5"
C Cushion Width Front	15"
D Cushion Width Rear	13"
E Cushion Length	19"
F Overall Width Thigh	22"
G Overall Width Waist	21.5"
H Overall Width Shoulder	22"
I Back Height	28"
J Overall Height	32.5"
K Rails	9"
L Bolster Height	3"
M Shoulder Slots	21"

Weight 21lb  
Angle 73

### APEX

A Base Width	16"
B Base Length	22"
C Cushion Width Front	13"
D Cushion Width Rear	10.5"
E Cushion Length	19"
F Overall Width Thigh	21.5"
G Overall Width Waist	22"
H Overall Width Shoulder	21.5"
I Back Height	29"
J Overall Height	31.75"
K Tabs	14" x 18"
L Bolster Height	5"
M Shoulder Slots	21"

Weight 17lb  
Angle 77