

# 2020 SNOW CATALOG



 **VENOM**<sup>TM</sup>  
P R O D U C T S



# TABLE OF CONTENTS

TEAM® TIED SECONDARY CLUTCH & CLUTCH KITS.....	2
C-TEC2 ARCTIC CAT M8/M8000/ALPHA 1 CLUTCH KIT.....	2
SKI-DOO XP TIED CONVERSION KITS.....	3
TEAM® TSS-04 CLUTCH.....	3
HELIXES.....	4-7
TWIN TRAX HELIX CHART.....	4
TEAM® TIED CLUTCH HELIXES.....	5
2016-Up ARCTIC CAT TEAM® B.O.S.S. CLUTCH HELIXES.....	5
TEAM® TSS-04 CLUTCH HELIXES ENGINE REVERSE (ER) SUPPORT.....	6
TEAM® TSS-04 CLUTCH HELIXES NON ENGINE (NON-ER) REVERSE SUPPORT.....	7
TEAM® TSS-98 CLUTCH HELIXES (CUSTOM CUT ONLY).....	7
HIGH TENSILE STEEL SECONDARY SPRINGS FOR TEAM® TSS-98, TSS-04 & TIED CLUTCHES.....	8
HIGH TENSILE STEEL SECONDARY SPRINGS FOR ARCTIC CAT B.O.S.S. CLUTCH.....	8
HIGH TENSILE STEEL SECONDARY SPRINGS FOR FACTORY SKI-DOO QRS.....	8
SECONDARY DELRIN WASHERS.....	8
HIGH TENSILE STEEL PRIMARY SPRINGS.....	9
PRIMARY DELRIN WASHERS.....	9
ROOSTER™ ADJUSTABLE SHIFT WEIGHT KITS.....	10
ROOSTER™ REPLACEMENT WASHERS & FASTENERS.....	10
YAMAHA CLUTCH WEIGHT CONVERSION KIT.....	10
ROOSTER™ ADJUSTABLE PIVOT KIT FOR SKI-DOO PDRIVE.....	10
ROOSTER™ ADJUSTABLE PIN KITS FOR SKI-DOO.....	10
ARCTIC CAT B.O.S.S. TORLON® ROLLER UPGRADE.....	11
SKI-DOO PDRIVE REPLACEMENT ROLLERS.....	11
FLOATER KITS.....	11
SKI-DOO TRA PRIMARY FORKS ASSEMBLY TOOLS.....	11
SKI-DOO TRA RAMPS.....	12
SKI-DOO TRA RAMP PROFILES.....	12
CLUTCH ALIGNMENT TOOLS.....	13
VENOM™ COMPRESSION TOOLS.....	13
VENOM™ COMPRESSION TOOL CUP FOR SKI-DOO PDRIVE.....	13
PRIMARY CLUTCH PULLERS.....	13
SNOW BELT REMOVAL TOOLS.....	13
CHAINS & SPROCKETS	
ARCTIC CAT TOP SPROCKETS.....	14
ARCTIC CAT BOTTOM SPROCKETS.....	15
2012-16 ARCTIC CAT PROCROSS & PROCLIMB 4 STROKE HY-VO® CONVERSION KITS.....	15
2012-16 ARCTIC CAT PROCROSS & PROCLIMB 2 STROKE HY-VO® CONVERSION KITS.....	16
POLARIS OEM REPLACEMENT SPROCKETS.....	17
SKI-DOO OEM REPLACEMENT SPROCKETS.....	18
SKI-DOO HY-VO® CONVERSION SPROCKETS.....	19
YAMAHA OEM REPLACEMENT SPROCKETS.....	20
VENOM™ CHAINCASE OIL.....	16-20
DRIVE CHAINS.....	16-21
SECONDARY CLUTCH REPLACEMENT PARTS: TEAM® TIED, TSS-04, TSS-98.....	22-23

# CLUTCHING TROUBLESHOOTING TIPS

You must make sure EVERY part of your drivetrain is working before you start tuning on your clutches. The first things to check before you go buy clutch tuning components are:

- Is your motor running like it should? *If you cannot pull stock clutching, you have an issue somewhere.*
- Do you have a fresh, broken-in belt? *Even though your belt may not be shot, it could be worn to the point where you don't get the same performance.*
- How are your motor mounts? *A motor that moves in the chassis under power will not keep clutch alignment and calibrations go out the window.*
- Are your clutches in alignment? *Check your alignment with one of our alignment bars.*
- Do you have sufficient traction? *A studded track is a must for flatlanders if you want consistent results.*



Once you have all of these things in line, here are some tips to get your clutching spot on. The first and most important key to getting good clutching is to have good data. This means a recording tachometer or other playback device. In my years in this business I have learned that people cannot watch a tach and give good feedback. It's also dangerous. Max recall on a stock tach is meaningless, also. Once you have good data, these are some of the things that can happen on full throttle pulls from a dead stop: (RPM on the left scale, and MPH on the bottom scale).

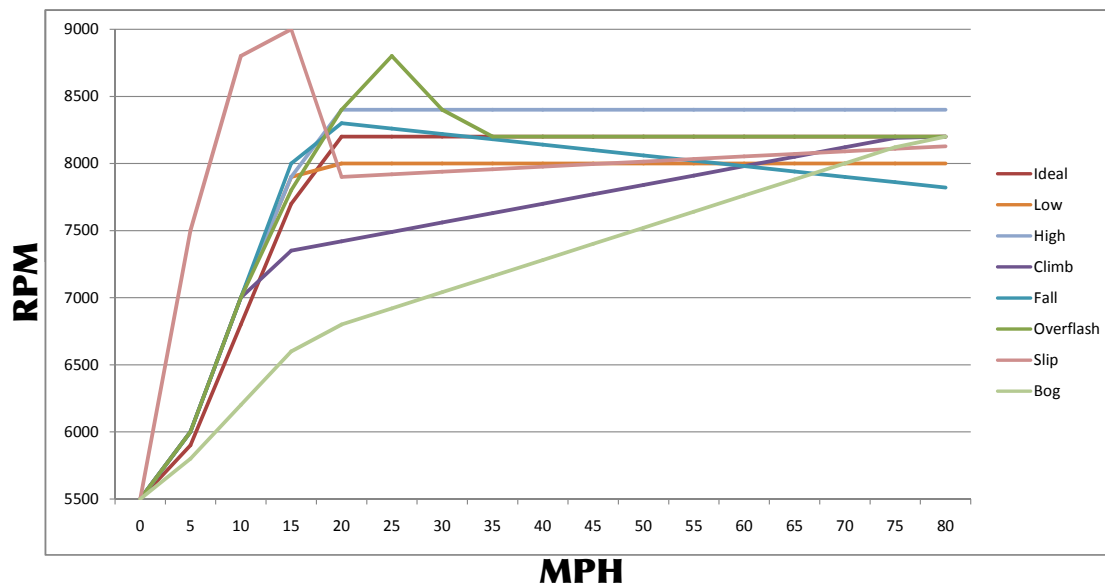

- **Ideal**- The ideal shift curve climbs to your rpm of max horsepower quickly and stays there throughout. *This graph assumes 8200 is the ideal RPM.*
- **Low**- If your RPM is low throughout the shift curve, you are over-clutched. *You need to drop gram weight in the drive or drop helix angle (initial and final) in the driven. Going up on spring rates in both the drive and driven clutches will also raise operating RPM.*
- **High**- If your RPM is high throughout the shift curve, you are under-clutched. *You need to raise gram weight in the drive or raise helix angle (initial and final) in the driven. Going down on spring rates in both the drive and driven clutches will also lower operating RPM.*
- **Climb**- If your shift curve climbs, you have too much helix at the beginning and/or not enough initial driven clutch spring. *If you are using adjustable shift weights, you may have too much weight in the heel of the weight (nearest the pin).*
- **Fall**- If your shift curve drops, you have too much helix angle at the finish, too much gram weight in the drive, and/or too much initial driven clutch spring. *If you are using adjustable shift weights, you might have too much weight in the tip of the weight (farthest from the pin.)*
- **Overflash**- This occurs when the drive clutch has complete traction on the belt, but the driven clutch does not let it shift soon enough. *More initial helix angle and dropping driven spring preload will fix this.*
- **Slip**- This looks like overflash, but the motor is bouncing off the rev limiter at the start. *This is caused by the drive clutch not getting full traction on the belt. This can be caused by too much gearing, not enough initial helix angle, too hard of a belt compound, too much drive clutch spring preload, and not enough heel weight in the drive clutch weights.*
- **Bog**- While similar to climb, a bog is more pronounced and can indicate a belt that is shot, a motor problem, or a broken motor mount. *A bog that bad generally is not due to clutch tuning.*





## TEAM® TIED SECONDARY CLUTCH

The TEAM® Tied secondary clutch is an improvement from the TSS-04 because the moveable sheave opens axially to the stationary sheave without rotational movement. This translates to no scrubbing motion on the belt face.

Additionally, all torque is transmitted through the helix, making clutch tuning much more precise. This clutch was developed using the extensive testing and design resources of TEAM Industries, Inc., and is sure to help you achieve the performance you've been looking for.

Part No.	Description
421438	1" Keyed Arctic Cat (Pre-Diamond Drive* see next line) & Pre 2005 Polaris
930194AK	*Adaptor Kit Needed if replacing Pre-Diamond Drive Arctic Cat clutch
421896	ProClimb / ProCross - Only uses "AC" Helixes
421511	Polaris Splined
421515	Ski-Doo Splined
421512	Yamaha Splined - Except Nytro, FX, Phazer, and SR Viper

**NOTE:** Tied Clutch does not include helix or spring. See page 5 for the helix selection and page 8 for the spring selection.



- More efficient than non-tied designs
- Longer Belt Life
- 16-18° higher helix angles than TSS-04
- Eliminates engine reverse clunk
- Backshifts faster than the TSS-04

## TEAM® TIED CLUTCH KITS

Upgrade your machine to the unmatched performance of the TEAM® Tied clutch with this complete kit that includes a Tied Driven clutch, spring and helix. Belt life issues are cured with this kit. You will see instant backshift and be able to hold RPM over greater changes in elevation with this kit. This clutch works with the stock drive clutch setup.



### ARCTIC CAT

Part No.	Year	Description	Elevation
520908	2012-15	Complete - 240HP XF1100 *	0-3,000 ft.
520910	2012-15	Stock XF1100 Clutch Kit	0-3,000 ft.
520911	2014-15	ZR/XF 6000	0-3,000 ft.
520902	2012-15	M8 153" or 162" track, requires 20/49 or 19/50 gearing. See Gearing Section	6,000-9,000 ft.
520903	2012-15	M1100 turbo 153" or 162" track	6,000-9,000 ft.

\* XF/F1100 Turbo tested with 3" Exhaust & 240 hp ECU Flash. #520908 includes drive spring, weights, driven clutch, spring and helix.

### POLARIS RMK PRO

Part No.	Year	Description	Elevation
520912	2016-20	Axys RMK 800-155 inch track	6,000-9,000 ft.
520900	2011-16	Pro RMK 800-155 inch track	6,000-9,000 ft.
520901	2011-16	Pro RMK 800-163 inch track	6,000-9,000 ft.
520914	2019-20	Patriot RMK 850, All Track lengths <b>NEW</b>	6,000-9,000 ft.

## C-TEC2 ARCTIC CAT M8/M8000/ALPHA 1 CLUTCH KIT

We developed a clutch kit for the 2017-Up Arctic Cat M8 that really performs. This kit includes both a Primary and Secondary spring, as well as a custom helix. Also for the 2017-Up M8 we have the upper sprockets in case you want to vary from the stock ratios.



### ARCTIC CAT

Part No.	Year	Description	Elevation
521100	2017-Up	Arctic Cat M8/M8000/Alpha 1 - 2017-Up <b>NEW</b>	6,000-9,000 ft.

# SKI-DOO® XP TIED CONVERSION KITS

Take your XP to the next level with the TEAM® TIED Conversion Kit! Upgrade your sled to the performance that non-tied clutches cannot deliver. The XP TIED conversion kit comes with all the parts you need to install the patented TEAM® TIED clutch and the Tuning components to make it rip! We recommend purchasing the appropriate alignment bar (Part #930721) to aid in kit installation.

SKI-DOO			
Part No.	Year	Description	Elevation
850103	2016-Up	850 Renegade	0 - 3,000 ft.
850101	2016-Up	Summit 850 163/154 3"	6,000 - 9,000 ft.
850102	2016-Up	Summit 850 154/145	6,000 - 9,000 ft.
520179-TH	2011-16	Summit 800 E-Tec	6,000 - 9,000 ft.
520193-TH	2011-16	Renegade 800 E-Tec	0 - 3,000 ft.
520194-TH	2011-16	MXZ 800 E-Tec	0 - 3,000 ft.
520196-TH	2011-16	Summit 800 E-Tec	0 - 3,000 ft.
520197-TH	2011-16	Summit 800 E-Tec	3,000 - 6,000 ft.
520170-TH	2008-16	Summit XP 600	6,000 - 9,000 ft.
520165-TH	2008-10	Summit XP 800 163"	6,000 - 9,000 ft.
520163-TH*	2008-10	Summit XP 800	0 - 3,000 ft.
520160-TH*	2008-10	Summit XP 800	6,000 - 9,000 ft.
520177-TH	2008-10	MXZ 500 SS XP	0 - 3,000 ft.
520168-TH	2008-16	MXZ 600 E-Tec	0 - 3,000 ft.
520161-TH	2008-10	MXZ XP 800	0 - 3,000 ft.
520162-TH	2008-10	Renegade XP 800	0 - 3,000 ft.
520182K	2011-16	Hollow Shaft ONLY - Call about fitment for 2017	
520183K	2017-Up	Gen 4, 2 Stroke - Hollow Jackshaft Kit	

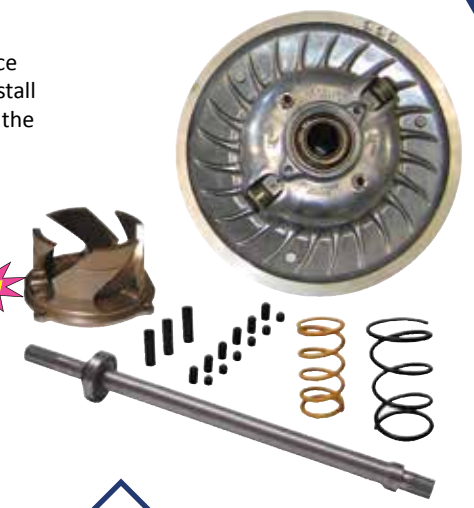

- Kit include the following parts:
- Hollow Jackshaft
  - TIED Secondary Clutch
  - Twin Trax™ Helix
  - Drive Spring
  - Driven Spring
  - Adjustable Pin Kit

\* Also Includes Chain and Top Sprocket

# TEAM® RAPID REACTION® TSS-04 SNOW CLUTCH

The TEAM® TSS-04 eliminates binding seen in a button clutch by separating the moveable alignment from the moveable action. This clutch has been proven on racetracks throughout the world. You can have the clutch that comes on all factory snocross machines.

Part No.	Description
420283 LW	Arctic Cat - This clutch will work on Pre-Diamond Drive chaincase models only.
930765	Polaris keyed 1" shaft - Pre 2006
930763	Ski-Doo splined 2000-2007 & 2008-Up with jackshaft conversion

**NOTE: TSS-04 CLUTCH DOES NOT INCLUDE HELIX OR SPRING.**  
See Pages 6-7 for the helix selection and Page 8 for the spring selection.

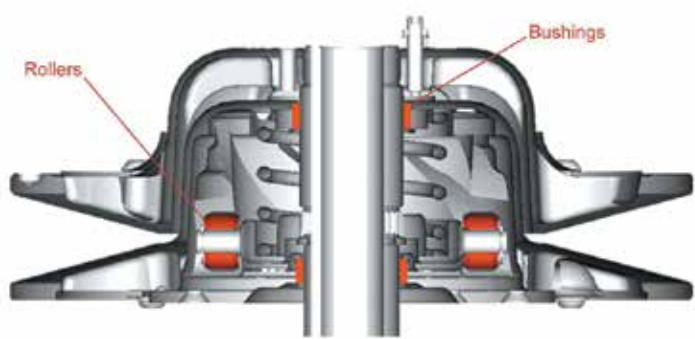

Patent No. 6,120,399 - Continuously Variable Transmission Driven Element

- One pound lighter than the TSS-98
- Optimized rib design improves cooling with less wind drag
- Twin Trax™ helix requires only four fasteners
- Twin enclosed rollers
- Improved length to diameter ratio on bushings
- Smooth up shift and back shift
- Tunable with helix angles and springs
- Increases efficiency



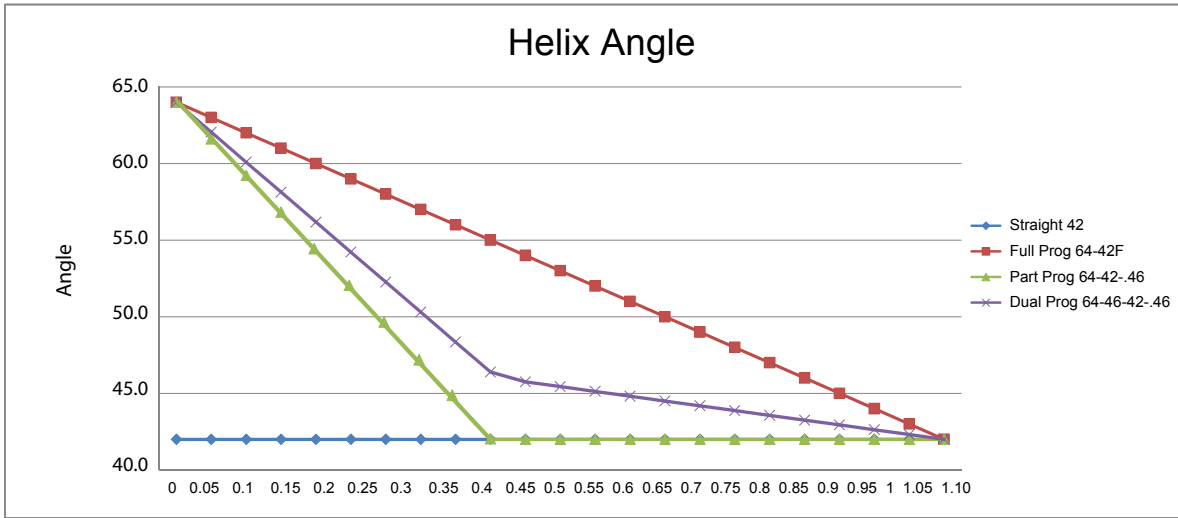

**NOTE:** ER is for machines with engine reverse. *S*=Straight *F*=Full Progressive *.46*=*.46* Progressive. Custom helices are available on request.

### STRAIGHT TWIN TRAX™ HELIX

STRAIGHT	
Shift Position	Angle
0	42
0.1	42
0.2	42
0.3	42
0.4	42
0.5	42
0.6	42
0.7	42
0.8	42
0.9	42
1	42
1.1	42

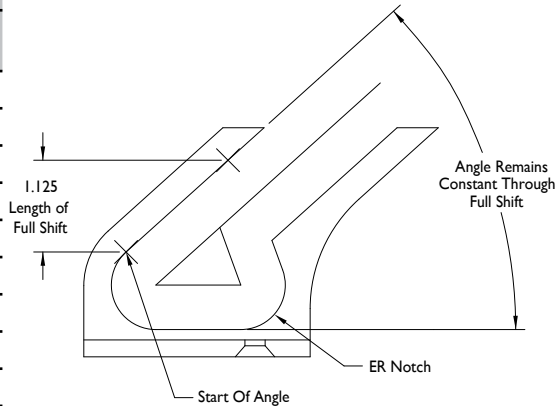

### PARTIAL PROGRESSIVE TWIN TRAX™ HELIX

PARTIAL	
Shift Position	Angle
0	64.0
0.1	59.2
0.2	54.4
0.3	49.7
0.4	44.9
0.5	42.0
0.6	42.0
0.7	42.0
0.8	42.0
0.9	42.0
1	42.0
1.1	42.0

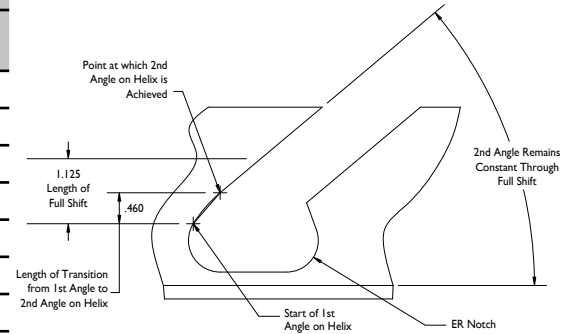

### FULL PROGRESSIVE TWIN TRAX™ HELIX

FULL	
Shift Position	Angle
0	64
0.1	62
0.2	60
0.3	58
0.4	56
0.5	54
0.6	52
0.7	50
0.8	48
0.9	46
1	44
1.1	42

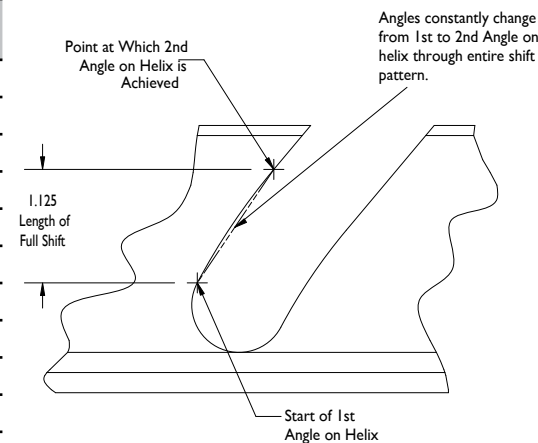

### DUAL PROGRESSIVE TWIN TRAX™ HELIX

DUAL	
Shift Position	Angle
0	64.0
0.1	60.1
0.2	56.2
0.3	52.3
0.4	48.3
0.5	45.8
0.6	45.1
0.7	44.5
0.8	43.9
0.9	43.3
1	42.6
1.1	42.0

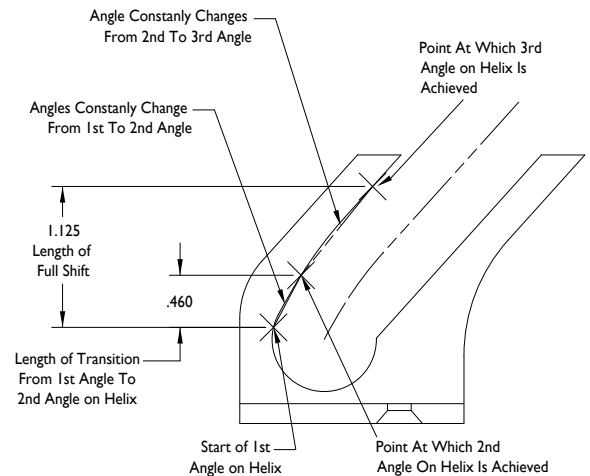

## TEAM® TIED CLUTCH HELIXES

The Twin Trax™ helix produces a quick up-shift and improved back-shift for excellent throttle response. The dual-angle option helix offers fine-tuning for changing conditions. These unique components are available in a variety of multi angles for almost any application. If you don't see the angles you want, we can cut a custom helix just for you for \$109.00. **All helixes are available for Arctic Cat® ProCross/ProClimb. When ordering precede part number with "AC". (Ex: AC960002.)**



**RETAIL \$109.00**  
**CUSTOM CUT HELIX \$109.00**

Part No.	1st Track	Type	2nd Track	Type
960032	50	STRAIGHT	52	STRAIGHT
960035	57 ER	STRAIGHT	59 ER	STRAIGHT
960041	60 ER	STRAIGHT	62 ER	STRAIGHT
960003	61 ER	STRAIGHT	63 ER	STRAIGHT
960008	63 ER	STRAIGHT	67 ER	STRAIGHT
960049	71-55 ER	0.36	71-57 ER	0.36
960050	73-55 ER	0.36	73-57 ER	0.36
960022	71-55	0.46	71-57	0.46
960033	71-55 ER	0.46	71-57 ER	0.46
960034	73-55 ER	0.46	73-57 ER	0.46
960005	70-57 ER	0.46	70-59 ER	0.46
960048	71-57 ER	0.46	71-59 ER	0.46
960000	73-57 ER	0.46	73-59 ER	0.46
960019	75-57 ER	0.46	75-59 ER	0.46
960021	77-57 ER	0.46	77-59 ER	0.46
960026	75-57 ER	0.56	75-59 ER	0.56
960023	77-57 ER	0.56	77-59 ER	0.56
960036	62-58 ER	0.33	64-60 ER	0.33
960038	75-59 ER	0.46	75-61 ER	0.46
960039	73-59 ER	0.46	73-61 ER	0.46
960024	77-59 ER	0.56	77-61 ER	0.56
960025	75-59 ER	0.56	75-61 ER	0.56
960055	73-59 ER	0.36	73-61 ER	0.36
960009	66-60 ER	0.33	66-62 ER	0.33

Part No.	1st Track	Type	2nd Track	Type
960006	73-61 ER	0.46	73-63 ER	0.46
960010	76-61 ER	0.46	73-61 ER	0.36
960004	76-61 ER	0.46	76-63 ER	0.46
960014	78-61 ER	0.46	78-63 ER	0.46
960001	80-61 ER	0.46	80-63 ER	0.46
960007	81-61 ER	0.46	80-64 ER	0.46
960015	78-63 ER	0.46	78-65 ER	0.46
960016	73-63 ER	0.46	73-65 ER	0.46
960002	70-63 ER	0.46	63 ER	STRAIGHT
960056	76-63 ER	0.36	76-61 ER	0.36
960011	73-64 ER	0.36	73-66 ER	0.36
960037	55-52	FULL	57-54	FULL
960044	62-54 ER	FULL	64-56 ER	FULL
960045	64-54 ER	FULL	66-56 ER	FULL
960013	64-60 ER	FULL	66-62 ER	FULL
960012	68-63 ER	FULL	70-65 ER	FULL
960052	70-56	FULL	68-54	FULL
960053	78-60-52	0.60/Dual	78-62-54	0.60/Dual
960018	78-62-57	0.46/Dual	78-64-59	0.46/Dual
960017	78-63-61 ER	0.46/Dual	80-65-61 ER	0.46/Dual
960047	58-62 ER	0.36	60-64 ER	0.36
960054	58-62 ER	FULL	59-63 ER	FULL
960046	60-64 ER	0.36	62-66 ER	0.36

## 2016-Up ARCTIC CAT TEAM® B.O.S.S HELIXES

The TEAM® B.O.S.S. secondary clutch is equally impressive in its design and focus on quality. Featuring machined sheaves that mount directly to the machined-matched driven shaft. On the B.O.S.S. system, the moveable sheave (the sheave that moves to allow the belt to lower into the clutch) slides on the driven shaft, rather than on a separate steel post that's built into traditional driven clutches. The result is a 0.25 lb. weight reduction and quicker acceleration. The area of the driven shaft on which the clutch slides/moves is polished for improved performance and increased belt life. The shaft itself is larger diameter than traditional shafts.



Part No.	1st Track	Type	Part No.	1st Track	Type	Part No.	1st Track	Type
540000	47 ER	STRAIGHT	540005	52-47 NON-ER	FULL	540011	66-50 NON-ER	.20
540001	48 ER	STRAIGHT	540008	47-51 NON-ER	FULL			
540002	49 ER	STRAIGHT	540006	60-49 NON-ER	.20			
540003	50 ER	STRAIGHT	540007	62-47 NON-ER	.20			
540004	51 ER	STRAIGHT	540009	43-48 NON-ER	.20			
540012	54-48 ER	.30	540010	54-48 NON-ER	.15			

**NOTE:** NON-ER helixes DO NOT WORK with 2 stroke Engine Reverse machines.



# TEAM® TSS-04 HELIXES - ENGINE REVERSE (ER) SUPPORT

The Twin Trax™ helix produces a quick up-shift and improved back-shift for excellent throttle response. The dual-angle option helix offers fine-tuning for changing conditions. These unique components are available in a variety of multi angles for almost any application.



Part No.	1st Track	Type	2nd Track	Type
LW420490	38 ER	STRAIGHT	40 ER	STRAIGHT
LW420478	42 ER	STRAIGHT	44 ER	STRAIGHT
520101	46 ER	STRAIGHT	48 ER	STRAIGHT
LW420491	48 ER	STRAIGHT	50 ER	STRAIGHT
520107	50 ER	STRAIGHT	52 ER	STRAIGHT
LW420436	44 ER	STRAIGHT	54-44 ER	0.46
LW420718	46 ER	STRAIGHT	54-46 ER	0.46
520114	58-38 ER	0.36	58-40 ER	0.36
520116	56-38 ER	0.36	56-40 ER	0.36
520117	60-38 ER	0.36	60-40 ER	0.36
LW420776	60-38 ER	0.36	64-42 ER	0.36
LW420778	64-38 ER	0.36	64-40 ER	0.36
LW420405	54-38 ER	0.46	54-40 ER	0.46
LW420439	56-38 ER	0.46	56-40 ER	0.46
LW420407	58-38 ER	0.46	58-40 ER	0.46
LW420486	60-38 ER	0.46	60-40 ER	0.46
520112	44-40 ER	0.33	46-42 ER	0.33
520115	56-40 ER	0.36	56-42 ER	0.36
LW420734	58-40 ER	0.36	58-42 ER	0.36
LW420731	58-40 ER	0.46	58-42 ER	0.46
LW420406	54-40 ER	0.46	54-42 ER	0.46
LW420409	64-40 ER	0.46	64-44 ER	0.46
LW420716	48-42 ER	0.33	48-44 ER	0.33
LW420732	58-42 ER	0.36	62-42 ER	0.46
520118	60-42 ER	0.36	60-44 ER	0.36
LW420452	50-42 ER	0.46	50-44 ER	0.46

Part No.	1st Track	Type	2nd Track	Type
LW420408	58-42 ER	0.46	58-44 ER	0.46
LW420733	62-42 ER	0.46	62-44 ER	0.46
LW420493	64-42 ER	0.46	64-44 ER	0.46
LW420494	66-42 ER	0.46	66-44 ER	0.46
LW420412	70-42 ER	0.46	70-44 ER	0.46
LW420772	54-44 ER	0.36	54-46 ER	0.36
LW420773	58-44 ER	0.46	58-46 ER	0.46
LW420771	66-44 ER	0.46	66-46 ER	0.46
LW420422	70-44 ER	0.46	70-46 ER	0.46
LW420492	62-46 ER	0.46	62-48 ER	0.46
520130	64-46 ER	0.46	68-46 ER	0.46
LW420487	56-36 ER	FULL	56-38 ER	FULL
LW420739	58-36 ER	FULL	58-38 ER	FULL
LW420800	42-32 ER	FULL	46-34 ER	FULL
520103	42-38 ER	FULL	44-40 ER	FULL
LW420767	46-42 ER	FULL	48-44 ER	FULL
LW420766	50-44 ER	FULL	52-46 ER	FULL
LW420737	54-44 ER	FULL	54-46 ER	FULL
LW420738	56-44 ER	FULL	56-46 ER	FULL
LW420719	66-44-42 ER	0.46/Dual	70-46-42 ER	0.46/Dual
LW420720	66-46-42 ER	0.46/Dual	70-48-44 ER	0.46/Dual
520121	40-46 ER	0.36	40-46 ER	0.56
520140	42-46 ER	0.36	44-48 ER	0.36
520122	42-48 ER	0.36	42-48 ER	0.56
520123	44-50 ER	0.36	44-50 ER	0.56





## TEAM® TSS-04 HELIXES - NON ENGINE REVERSE (ER) SUPPORT

The Twin Trax™ helix produces a quick up-shift and improved back-shift for excellent throttle response. The dual-angle option helix offers fine-tuning for changing conditions. These unique components are available in a variety of multi angles for almost any application.



Part No.	1st Track	Type	2nd Track	Type
LW420423	34	STRAIGHT	36	STRAIGHT
LW420562	38	STRAIGHT	42	STRAIGHT
LW420563	40	STRAIGHT	44	STRAIGHT
LW420453	42	STRAIGHT	44	STRAIGHT
LW420564	42	STRAIGHT	46	STRAIGHT
LW420565	44	STRAIGHT	48	STRAIGHT
LW420721	46	STRAIGHT	48	STRAIGHT
LW420566	46	STRAIGHT	50	STRAIGHT
LW420568	50	STRAIGHT	54	STRAIGHT
LW420437	54-44	0.46	44	STRAIGHT
LW420520	54-34	0.46	54-36	0.46
LW420512	54-36	0.46	54-38	0.46
LW420514	54-38	0.46	54-40	0.46
LW420515	58-38	0.46	58-40	0.46
LW420518	60-38	0.46	60-40	0.46
LW420546	58-40	0.46	58-42	0.46
LW420525	62-40	0.46	62-44	0.46
LW420538	66-40	0.46	66-44	0.46
LW420522	74-40	0.46	74-44	0.46
LW420451	50-42	0.46	50-44	0.46
LW420516	54-42	0.46	54-44	0.46
520100	58-42	0.30 T	58-44	0.30 T
LW420517	58-42	0.46	58-44	0.46
LW420573	70-42	0.46	70-44	0.46

Part No.	1st Track	Type	2nd Track	Type
520119	60-44	0.25 T	64-44	0.25 T
520120	62-44	0.25 T	66-44	0.25 T
520113	68-44	0.26 T	72-44	0.26 T
520106	74-44	0.36	74-46	0.36
520124	58-44	0.46	58-46	0.46
LW420519	58-44	0.46	60-48	0.46
LW420561	66-44	0.46	70-44	0.46
LW420574	72-44	0.46	70-48	0.46
LW420537	66-44	0.56	66-44	0.46
LW420552	70-46	0.46	72-48	0.46
LW420745	58-46	0.36	58-48	0.36
LW420551	70-50	0.46	72-52	0.46
LW420509	58-40	0.46	52-40	FULL
LW420539	68-44	0.46	52-42	FULL
LW420540	70-48	0.46	54-44	FULL
LW420531	46-34	FULL	48-34	FULL
LW420570	48-38	FULL	50-40	FULL
LW420569	52-40	FULL	52-42	FULL
LW420571	54-42	FULL	54-44	FULL
LW420572	56-44	FULL	56-46	FULL
520105	58-44-34	0.46-Dual	58-46-36	0.46-Dual



## TEAM® TSS-98 HELIXES - CUSTOM CUT ONLY

If you have the older TSS98 clutch that came stock on the Polaris machines and were sold by TEAM Aftermarket back in the day, we can make helixes for you, as well. We don't stock any on the shelf, but we can cut any angle your mind can dream up.





## STEEL SECONDARY SPRINGS FOR TSS-98, TSS-04 and TIED

Secondary springs control shift rate. Fine-tune your TEAM® Rapid Reaction or TEAM® TIED secondary clutch with our springs manufactured to the most exacting specifications. We suggest using our Delrin Washer Kit, #930650. To maintain consistent clutching, we recommend inspecting and replacing your clutch springs yearly.



Part No.	Force lbs. @ 2.2" - 1.1"	Color
210180	100-150	Red/Yellow
210178	100-200	Red/White
210177	120-220	Red/Green
210179	125-175	Red/Gray
210181	140-200	Red/Dark Blue
210186	140-220	Black/Green
210176	140-240	Red/Black
210184	140-260	Red/Pink
210194*	140-300	Black/White/Red
210182	155-222	Black
210193	160-240	Black/Purple
210185	160-260	Black/White
210279*	160-280	Black/Silver
210278*	160-300	Black/Gold
955557*	175-240	Gold/Black
955556*	180-260	Black/Yellow
210280*	180-280	Black/Orange
210281*	180-300	Black/Lime Green

\* WILL NOT WORK ON TSS-98

## STEEL SECONDARY SPRINGS FOR AC B.O.S.S.

Secondary springs control shift rate. Fine-tune your Arctic Cat B.O.S.S. secondary clutch with our springs manufactured to the most exact specifications. We suggest using our Delrin Washer kit for the Arctic Cat B.O.S.S. clutch, #930651. To maintain consistent clutching, we recommend inspecting and replacing your clutch springs yearly.

Part No.	Color
<b>ARCTIC CAT - 2016 - Up</b> Force lbs. @ 2.600" - 1.600"	
210493-001	125-200 Green/Yellow
210493-002	140-200 Green/Red
210493-003	140-215 Green/Blue
210493-004	140-230 Green/Orange
210493-005	155-220 Green/Silver
210493-006	155-240 Green/Pink
210493-007	180-240 Green/Gold
210493-008	180-260 Green/Purple
210493-011	200-280 Green/Black



## SECONDARY DELRIN WASHERS - AC B.O.S.S.

The compression spring in the Arctic Cat B.O.S.S. clutch has to rotate in the spider as the clutch shifts. You can greatly reduce the scrubbing friction of the spring with the Delrin washer kit. Slippery Delrin washers go on top of the spring where it sits in the spider.

Part No.	Description
930651	Delrin Washer, AC B.O.S.S., 3pk



## STEEL SECONDARY SPRINGS FOR FACTORY SKI-DOO QRS

Secondary springs control shift rate. Fine-tune your Ski-Doo QRS secondary clutch with our springs manufactured to the most exact specifications. To maintain consistent clutching, we recommend inspecting and replacing your clutch springs yearly.



Part No.	Color
<b>SKI-DOO - 2008-Up</b> Force lbs. @ 61mm-35.2mm	
210270-002	180-303 Orange/Blue
210270-003	204-356 Orange/Purple
210270-004	215-380 Orange/Silver

# STEEL PRIMARY SPRINGS

Primary springs control engagement and shift RPM. Fine tune your primary clutch with Venom™ springs, manufactured from high tensile wire to exacting tolerances. To maintain consistent clutching, we recommend inspecting and replacing your clutch springs yearly.

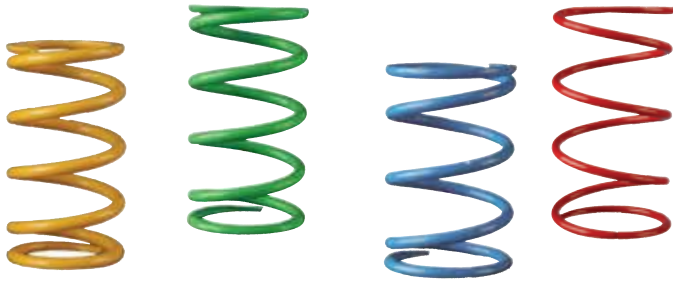

Part No.	Color	
<b>ARCTIC CAT - 2016-Up TEAM Rapid Response</b> Force lbs. @ 2.70" - 1.70"		
210800-010	100-200	Purple/Blue
210800-013	110-275	Purple/Yellow
210800-012	120-240	Purple/White
210800-011	125-210	Purple/Black
210800-014	130-250	Purple/Red
210800-015	130-280	Purple/Green
210800-017	150-290	Purple/Silver
210800-016	160-268	Purple/Orange
210800-018	170-280	Purple/Pink
210800-019	170-300	Purple/Gold
<b>ARCTIC CAT - PRE 2016</b> Force lbs. @ 2.562" - 1.312"		
210210-007	110-320	Lime Green/Light Blue
210210-001	114-267	Lime Green/Yellow
210210-008	120-330	Lime Green/Gold
210210-002	121-240	Lime Green/Purple
210210-003	122-285	Lime Green/White
210210-006	125-310	Lime Green/Black
210210-004	143-290	Lime Green/Orange
210210-005	158-290	Lime Green/Red

Part No.	Color	
<b>POLARIS</b> Force lbs. @ 2.50" - 1.19"		
210135-002	100-275	Black
210135-015	120-270	Black/Pink
210135-003	120-310	White
210135-008	120-340	Bright Yellow
210135-004	140-320	Red
210135-001	140-330	Green
210135-014	145-295	Black/Bright Green
210135-006	150-310	Blue
210135-009	150-340	Bright Green
210135-005	165-310	Orange
210135-010	165-327	Almond
210135-011	165-344	Silver
210135-013	180-320	Pink
210135-012	180-345	Gold

Part No.	Color	
<b>SKI-DOO pDRIVE</b> Force lbs. @ 73.6mm-39.2mm		
210604-001	165-350	Yellow/Purple/Blue
210604-002	170-375	Yellow/Purple/Pink
210604-003	170-400	Yellow/Purple/Red
210604-004	200-330	Yellow/Purple/Green
<b>SKI-DOO</b> Force lbs. @ 74mm-42mm		
210141-016	130-350	Black/Pink
210141-010	150-240	Yellow/Gold
210141-008	160-260	Yellow/Purple
210141-001	160-290	Yellow/Green
210141-013	160-320	Yellow/Almond
210141-017	160-350	Black/Purple/Pink
210141-014	160-380	Yellow/Purple/White
210141-003	200-290	Yellow/Red
210141-002	200-320	Yellow/Blue
210141-011	200-380	Yellow/Pink
210141-004	230-350	Yellow/Black
210141-005	230-380	Yellow/Orange
210141-009	240-430	Yellow/Light Blue
210141-015	270-460	Yellow/Black - Green

Part No.	Color	
<b>YAMAHA</b> Force lbs. @ 73.66mm-33mm (2.900" - 1.300")		
210220-001	77-260	Blue/White
210220-002	77-277	Blue/Yellow
210220-008	77-295	Blue/Yellow/White
210220-003	77-315	Blue/Green
210220-004	88-288	Blue/Silver
210220-005	88-306	Blue/Orange
210220-006	99-282	Blue/Purple
210220-007	99-299	Blue/Red

## PRIMARY DELRIN WASHERS

The compression spring in the Arctic Cat and Polaris OEM primary clutch has to rotate in the spring pocket as the spring compresses. You can greatly reduce the scrubbing friction of the spring with the Delrin washer kit. Slippery Delrin washers go on top and bottom of the spring and spring cup.

Part No.	Description
930653	Primary Delrin Washer Kit, 3pk





## ROOSTER™ ADJUSTABLE SHIFT WEIGHT KITS

Rooster™ Adjustable Shift Weight Kits for Arctic Cat, Polaris and Ski-Doo applications. Adjust your shift curve and compensate for altitude and/or modifications by adding or subtracting weight on the flyweight. Extra heavy gram weights are possible with the optional tungsten kit.

Part No.	Description
930994	Arctic Cat 2016-Up weight adjustable from 60g-80g
932014	Arctic Cat 2016-Up Fastener Upgrade Kit - Adds more 8g to kit #930994
930974	Arctic Cat weight adjustable from 64.5g-84.5g (set screw clutches)
930997	Polaris 10 series adjustable from 56g-76g *
930973	Polaris 10 series for turbo applications, adjustable from 65g-80g *
930999	Polaris 10 series with tungsten adjustable 56g-94g *
930972-33	Classic Polaris P85, 33g-50g (10 Series)
930958	Tungsten Washer Kit (12 Washers 3.5g each)

\* Can be used in Yamaha drives with kit #930955-YM



\*Kit may vary from photo.

## ROOSTER™ REPLACEMENT WASHERS & FASTENERS

Part No.	Description
931001	Aluminum Fastener, 0.8g
931002	Steel Blue Fastener, 2.0g
931000	Steel Green Fastener, 2.5g
930946	Steel Red Fastener, 3.5g
930947	Steel Fastener, 6.0g
930943	Thin Washer, 0.5g
930944	Thick Washer, 1.5g
930945	Tungsten Washer, 3.5g
930958	Set of 12 Tungsten Washers
931997	Set of 3 Bushings for Kits #930973, 930997 & 930999
931999	Set of 3 Bushings for Kits #930972, 930994 & 932014

- Weights adjustable by .5 gram increments
- Includes Thread Locker
- Bushed weights
- Color coded fasteners
- Convenient carrying case

## YAMAHA CLUTCH WEIGHT CONVERSION KIT

This is a great inexpensive update for your Yamaha clutch. With this kit you can run 10 series Polaris weights in your sled. Testing showed a huge gain on the top end.

Part No.	Description
930955-YM	Yamaha Clutch Weight Conversion Kit



Kit comes complete with bushings, pins, and nuts.

## ROOSTER™ ADJUSTABLE pDRIVE PIVOT KIT

Adjust the gram weight of your Ski-Doo pDrive drive clutch shift weight, or "Pivot" as Ski-Doo calls it, with the Venom Rooster™ Adjustable Pivot kit. This kit allows you to adjust from 13.1 grams to 25.85 grams.

Part No.	Description
933001	Ski-Doo pDrive, 2017-Up, Adjustable Pivot Weight Kit



## ROOSTER™ ADJUSTABLE PIN KITS

Adjustable Pin Kits for all Ski-Doo snowmobiles with TRA 2, TRA 3, or TRA 5 primary clutches. Beware of pin kits that are too long to clear the TRA 3 governor cap or have too high of a surface finish. Our pin kits are machined to OEM specifications for surface finish and allow full shiftout.

Part No.	Description
930940	Ski-Doo Pin Kit, 10.5 to 15.5 Grams
930941	Ski-Doo Pin Kit, 13.8 to 19.6 Grams
930954	Ski-Doo Pin Kit, 13.8 to 23.2 Grams (Includes Tungsten)



## ARCTIC CAT B.O.S.S. TORLON® ROLLER UPGRADE

Venom Products High Performance Torlon® Rollers for the Arctic Cat B.O.S.S. clutch. This is also an upgrade from the factory rollers. **SOLD INDIVIDUALLY.**

Torlon® is a high performance amorphous (non-crystalline) engineering thermoplastic. Chemically, Torlon® is a polyamide-imide (PAI), a reaction product of trimellitic anhydride and aromatic diamines. The combination of aromatic groups and imide linkages are responsible for the polymer's exceptional thermal stability. The amide groups impart flexibility and elongation, which results in an engineering plastic with exceptional toughness. The result of this is a more consistent tune in different conditions and loads.



### Arctic Cat B.O.S.S. - Roller Upgrade

Part No.	Description
----------	-------------

460329	Roller Upgrade, EACH
--------	----------------------

## SKI-DOO pDRIVE REPLACEMENT ROLLERS

Vespe® Replacement Drive Rollers, Ski-Doo pDrive Primary Clutch, (Set of 3). Use these fast and friction-free dual Vespe® rollers to transfer torque. Vespe® comes standard in the RS600 race drive clutches.

Part No.	Description
----------	-------------

931008	Drive Roller, (Set of 3) Ski-Doo pDrive
--------	-----------------------------------------

931009	Back Drive Roller, (Set of 3) Ski-Doo pDrive
--------	----------------------------------------------



#931009



#931008

## FLOATER KITS

Our floater kit allows you to “float” your TEAM® clutch when used with our jackshaft conversion kits. Under torque, the motor in the XP chassis moves slightly, causing misalignment of the drive and driven clutches. By floating the TEAM® clutch, it can eliminate this misalignment and greatly increase belt life and efficiency. Use part #990500 for the XP (two stroke) chassis. Venom Products **does not** recommend floating the driven clutch in 2012-15 Arctic Cat applications.

Part No.	Description
----------	-------------

990501	Arctic Cat Floater Plug (uses stock bolt)
--------	-------------------------------------------

990500	Ski-Doo Floater Plug (blot included in kit)
--------	---------------------------------------------



## TRA PRIMARY FORKS ASSEMBLY TOOL

A must for all Ski-Doo owners with a TRA drive clutch! This handy tool holds buttons in place when changing weights or springs.

Part No.	Description
----------	-------------

930207	TRA Primary Forks, Assembly Tool
--------	----------------------------------







# SKI-DOO TRA RAMPS

These ramps are precision machined from billet steel. The shift angles mimic the stock Ski-Doo ramps. All steel ramps are lighter than stock and matched in weight for balance. Set of 3.

Part No.	Description
TRA2-10003	CFI Duplication
TRA2-10001	PX Duplication
TRA2-10005	145 Duplication
TRA2-10004	297 Duplication
Part No.	Description
TRA3-10003	412 Duplication
TRA3-10018	413 Duplication
TRA3-10002	414 Duplication
TRA3-10013	415 Duplication
TRA3-10017	415/441 Combo
TRA3-10001	419 Duplication
TRA3-10016	441 Duplication



TRA2-10004



TRA2-10003



TRA2-10001



TRA2-10005



TRA3-10017



## SKI-DOO TRA RAMP PROFILES

TRA3-10003



TRA3-10013



TRA3-10018



TRA3-10001



TRA3-10002



TRA3-10016



## CLUTCH ALIGNMENT TOOL

Check and set clutch alignment quickly and easily with this precision tool, which slides over clutch fixed sheave for accuracy. If you are unsure of your belt width, you can measure with a standard tape measurer.

Part No.	Description
930720	TSS-04 or Tied with 1 3/8 belt. For use on Old Arctic Cat, Old Ski-Doo and Yamaha
930721	TSS-04 or Tied with 1 7/16 belt. For use on Polaris, Ski-Doo Rev & Newer, and 2012-2015 Arctic Cat
930722	TSS-04 or Tied with 1 1/2 belt.



Improper clutch alignment may cause:

- Loss of performance due to poor clutch efficiency
- Excessive clutch heat, resulting in extreme wear ridges on the sheaves
- Heat cracks that can cause clutch failure
- Poor fuel economy

## VENOM™ COMPRESSION TOOL

We made a couple changes to our compression tool for this year. We used a smaller thread so you can use it on primary clutches and other secondary clutches that the old tool would not fit through. We also made it possible to break down the tool so it fits in your toolbox better.

Some customer like our original design, so it will still be available under Part # 930001.

Part No.	Description
930001	Venom™ Compression Tool for all TEAM Rapid Reaction clutches
930003	Venom™ Compression Tool - (3/8" Rod - Not Shown) for all TEAM Rapid Reaction clutches



- Easy-to-use clutch spring compression tool
- Corrosion-resistant aircraft quality steel
- Compact, durable, impact-resistant

## VENOM™ COMPRESSION TOOL CUP FOR pDRIVE

Compression spring tool cup for changing primary springs in the Ski-Doo pDrive clutch. For use with the spring compression tool #930001.

Part No.	Description
920057	Venom™ Compression Tool Cup for Ski-Doo pDrive clutch



## PRIMARY CLUTCH PULLERS

We offer clutch pullers for all major brands: Arctic Cat, Polaris, Ski-Doo and Yamaha. Every puller is manufactured from the highest quality steel, heat treated for superior strength and precisely machined for accuracy.

Part No.	Description
920058	Arctic Cat 2010-Up (our Heavy Duty version of the AC blue puller)
920047	Polaris RZR 900 & Sleds After 2000
920054	Rapid Response® Drive Clutch Puller (Also fits Polaris Fuji)
920055	Ski-Doo pDrive Clutch Puller
920056	Ski-Doo pDrive Weight Axle Removal Tool



## SNOW BELT REMOVAL TOOL

Make changing belts easy. Designed exclusively for TEAM® Rapid Reaction® clutches.

Part No.	Description
930002	Clutch, Snow, Belt Removal Tool - TSS-98, TSS-04
650343	Clutch, Snow, Belt Removal Tool - TIED, AC B.O.S.S.





# CHAINS & SPROCKETS

To get optimal performance out of your machine, you need to gear it right. We offer a complete lineup of gears to fit your needs. Made of heat treated, case-hardened 8620 high-alloy steel, our CNC-machined sprockets are made in an ISO 9000 certified facility right here in the United States.



In 2016, Arctic Cat changed from Rexnord to BorgWarner HY-VO® drive chain and sprockets. Visually, this is the difference between the chains:



The sprockets for Rexnord chains must be used with Rexnord mating sprockets, the same is true for BorgWarner components. Two stroke sleds with engine reverse use a standard top sprocket. Four stroke sleds use a sprocket with engagement splines. Additionally the automatic tensioner on the Arctic Cat ProCross/ProClimb chassis cannot adjust far enough for many sprocket/chain combinations. We recommend using the kits on pages 15 & 16 to make sure the fitment is correct.

In 2018, Arctic Cat changed the internal spline on the mountain sleds and the XF High Country. These sprockets are listed in Table E.



Table D

## TOP SPROCKETS

Table A

AC 11W Rexnord (Pre 1994)		
VNM Part #	Description	AC Part #
351573-002	17T Sprocket, 13T Internal	N/A
351573-003	18T Sprocket, 13T Internal	0107-341
351573-007	22T Sprocket, 13T Internal	0107-301

Table B

AC 13W Rexnord 1994-2004		
VNM Part #	Description	AC Part #
351513-001	16T Sprocket, 13T Internal	N/A
351513-002	17T Sprocket, 13T Internal	N/A
351513-004	19T Sprocket, 13T Internal	0602-444
351513-005	20T Sprocket, 13T Internal	0602-456
351513-006	21T Sprocket, 13T Internal	N/A
351513-007	22T Sprocket, 13T Internal	N/A
351513-008	23T Sprocket, 13T Internal	N/A
351513-009	24T Sprocket, 13T Internal	0602-446
351513-010	25T Sprocket, 13T Internal	N/A

Table C

AC 13W Rexnord 2012-15 ProCross/ProClimb, 2 Stroke		
VNM Part #	Description	AC Part #
931065-013	17T Sprocket 19T Internal	N/A
931065-002	19T Sprocket 19T Internal	2602-582
931065-004	21T Sprocket 19T Internal	2602-377
931065-005	22T Sprocket 19T Internal	2602-403
931065-006	23T Sprocket 19T Internal	N/A
931065-007	24T Sprocket 19T Internal	N/A
931065-008	25T Sprocket 19T Internal	N/A
931065-009	26T Sprocket 19T Internal	N/A
931065-010	27T Sprocket 19T Internal	N/A
931065-011	28T Sprocket 19T Internal	N/A
931065-012	29T Sprocket 19T Internal	N/A

AC 13W BorgWarner 2016-17 & 2018-Up EXCEPT M or XF High Country (see next chart), 2 Stroke

VNM Part #	Description	AC Part #
931075-004	19T Sprocket, 19T Internal	2602-823
931075-005	20T Sprocket, 19T Internal	2602-824
931075-006	21T Sprocket, 19T Internal	2602-825
931075-007	22T Sprocket, 19T Internal	2602-826
931075-008	23T Sprocket, 19T Internal	2602-827
931075-009	24T Sprocket, 19T Internal	N/A
931075-010	25T Sprocket, 19T Internal	N/A
931075-011	26T Sprocket, 19T Internal	N/A



Table E

AC 3/4" BorgWarner 2018-Up M or XF High Country, 2 Stroke

VNM Part #	Description	AC Part #
931066-003	18T Sprocket 19T Internal	N/A
931066-005	20T Sprocket 19T Internal	3602-007
931066-006	21T Sprocket 19T Internal	3602-008
931066-007	22T Sprocket 19T Internal	3602-009
931066-009	24T Sprocket 19T Internal	N/A

Table F

AC 13W BorgWarner 2016-Up ProCross/ProClimb, 4 Stroke

VNM Part #	Description	AC Part #
422315-006	21T Sprocket, 33T Engagement	1702-351
422315-007	22T Sprocket, 33T Engagement	1702-382
422315-008	23T Sprocket, 33T Engagement	N/A
422315-009	24T Sprocket, 33T Engagement	1702-352
422315-010	25T Sprocket, 33T Engagement	N/A
422315-011	26T Sprocket, 33T Engagement	N/A
422315-012	27T Sprocket, 33T Engagement	N/A
422315-013	28T Sprocket, 33T Engagement	N/A



## BOTTOM SPROCKETS

AC 13W Rexnord 2012-15 ProCross/ProClimb	
VNM Part #	Description
931064-008	36T Sprocket 34T Internal
931064-009	37T Sprocket 34T Internal
931064-010	38T Sprocket 34T Internal
931064-011	39T Sprocket 34T Internal
931064-012	40T Sprocket 34T Internal
931064-014	42T Sprocket 34T Internal
931064-001	43T Sprocket 34T Internal
931064-002	44T Sprocket 34T Internal
931064-003	45T Sprocket 34T Internal
931064-004	46T Sprocket 34T Internal
931064-005	47T Sprocket 34T Internal
931064-006	48T Sprocket 34T Internal
931064-007	49T Sprocket 34T Internal
931064-015	50T Sprocket 34T Internal
931064-016	51T Sprocket, 34T Internal

AC 13W Rexnord 1994-2004	
VNM Part #	Description
351518-001	33T Sprocket, 15T Internal
351518-002	34T Sprocket, 15T Internal
351518-003	35T Sprocket, 15T Internal
351518-004	36T Sprocket, 15T Internal
351518-006	38T Sprocket, 15T Internal
351518-007	39T Sprocket, 15T Internal
351518-008	40T Sprocket, 15T Internal
351518-009	41T Sprocket, 15T Internal
351518-010	42T Sprocket, 15T Internal

AC 3/4" BorgWarner 2016-Up	
VNM Part #	Description
931076-005	42T Sprocket, 34T Internal
931076-006	43T Sprocket, 34T Internal
931076-007	44T Sprocket, 34T Internal
931076-008	45T Sprocket, 34T Internal
931076-009	46T Sprocket, 34T Internal
931076-010	47T Sprocket, 34T Internal
931076-011	48T Sprocket, 34T Internal
931076-012	49T Sprocket, 34T Internal
931076-013	50T Sprocket, 34T Internal

## PROCROSS & PROCLIMB 4 STROKE HY-VO® KITS

The automatic tensioner on the Procross/Proclimb chassis Cats will work with few top and bottom sprocket combinations. Venom Products has made it easy for you to pick your ratio with these HY-VO® kits. These kits can upgrade the 2012-15 machines from Rexnord to HY-VO® and the 2016 and newer machines come with HY-VO chains and sprockets. HY-VO® chains must be used with HY-VO® sprockets. All kits include a BorgWarner HY-VO® chain, a top sprocket and a bottom sprocket and can be used with the stock tensioner. Works with stock reverse. Don't forget to order chaincase oil, too.

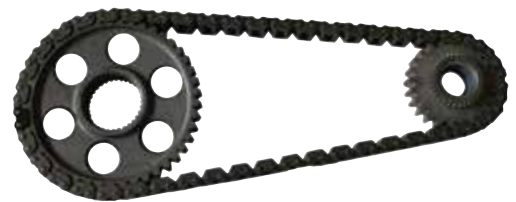

(See 2 Stroke on page 16)

Part No.	Description	Speed at 8000 RPM 1:1			Chain
		3.0 8T	2.86 9T	2.52 10T	
<b>4 Stroke HY-VO® Conversion Kits</b>					
520922	21/49 HY-VO® Conversion, 33T External Spline (Top)	86	92	90	90 link
520923	22/48 HY-VO® Conversion, 33T External Spline (Top)	92	98	96	90 link
520932	24/50 HY-VO® Conversion, 33T External Spline (Top)	96	103	101	92 link
520924	23/47 HY-VO® Conversion, 33T External Spline (Top)	98	105	103	90 link
520925	23/46 HY-VO® Conversion, 33T External Spline (Top)	100	107	105	90 link
520933	25/49 HY-VO® Conversion, 33T External Spline (Top)	102	109	107	92 link
520926	24/46 HY-VO® Conversion, 33T External Spline (Top)	104	112	110	90 link
520934	26/48 HY-VO® Conversion, 33T External Spline (Top)	108	116	114	92 link
520927	25/45 HY-VO® Conversion, 33T External Spline (Top)	111	119	117	90 link
520935	27/47 HY-VO® Conversion, 33T External Spline (Top)	115	123	121	92 link
520928	26/44 HY-VO® Conversion, 33T External Spline (Top)	118	127	124	90 link
520936	28/46 HY-VO® Conversion, 33T External Spline (Top)	122	131	128	92 link
520929	27/43 HY-VO® Conversion, 33T External Spline (Top)	126	135	132	90 link
520930	28/43 HY-VO® Conversion, 33T External Spline (Top)	130	140	137	90 link
520931	28/42 HY-VO® Conversion, 33T External Spline (Top)	133	143	140	90 link





# PROCROSS & PROCLIMB 2 STROKE HY-VO® CONVERSION KITS

The automatic tensioner on the Procross/Proclimb chassis Cats will work with few top and bottom sprocket combinations. Venom Products has made it easy for you to pick your ratio with these HY-VO® kits. These kits can upgrade the 2012-15 machines from Rexnord to HY-VO® and the 2016 and newer machines come with HY-VO chains and sprockets. HY-VO® chains must be used with HY-VO® sprockets. All kits include a BorgWarner HY-VO® chain, a top sprocket and a bottom sprocket and can be used with the stock tensioner. Don't forget to order chaincase oil, too.



Part No.	Description	Speed at 8000 RPM 1:1			Chain
		3.0 8T	2.86 9T	2.52 10T	
<b>2 Stroke HY-VO® Conversion Kits</b>					
520906	19/50 HY-VO® Conversion, 19T Internal Spline (Top)	76	82	80	90 link
520904	20/49 HY-VO® Conversion, 19T Internal Spline (Top)	82	88	86	90 link
520940	21/49 HY-VO® Conversion, 19T Internal Spline (Top)	86	92	90	90 link
520941	22/48 HY-VO® Conversion, 19T Internal Spline (Top)	92	98	96	90 link
520942	24/50 HY-VO® Conversion, 19T Internal Spline (Top)	96	103	101	92 link
520943	23/47 HY-VO® Conversion, 19T Internal Spline (Top)	98	105	103	90 link
520944	23/46 HY-VO® Conversion, 19T Internal Spline (Top)	100	107	105	90 link
520945	25/49 HY-VO® Conversion, 19T Internal Spline (Top)	102	109	107	92 link
520946	24/46 HY-VO® Conversion, 19T Internal Spline (Top)	104	112	110	90 link
520947	26/48 HY-VO® Conversion, 19T Internal Spline (Top)	108	116	114	92 link
520905	25/45 HY-VO® Conversion, 19T Internal Spline (Top)	111	119	117	90 link
520948	26/44 HY-VO® Conversion, 19T Internal Spline (Top)	118	127	124	90 link



## DRIVE CHAINS

3/4" BorgWarner HY-VO® chains for use with all HY-VO® 3/4" sprockets.



## DRIVE CHAINS

Rexnord® Silent Chains for use with Rexnord 13W sprockets.

Part No.	Description
930219	68 Link 3/4" Wide BorgWarner
930220	70 Link 3/4" Wide BorgWarner
930221	72 Link 3/4" Wide BorgWarner
930222	74 Link 3/4" Wide BorgWarner
930223	76 Link 3/4" Wide BorgWarner
930300	78 Link 3/4" Wide BorgWarner
930686	80 Link 3/4" Wide BorgWarner
930301	82 Link 3/4" Wide BorgWarner
930302	84 Link 3/4" Wide BorgWarner
930303	86 Link 3/4" Wide BorgWarner
930304	88 Link 3/4" Wide BorgWarner
930633	90 Link 3/4" Wide BorgWarner
930634	92 Link 3/4" Wide BorgWarner
930305	94 Link 3/4" Wide BorgWarner
930306	96 Link 3/4" Wide BorgWarner
930307	98 Link 3/4" Wide BorgWarner
930308	100 Link 3/4" Wide BorgWarner
930309	102 Link 3/4" Wide BorgWarner
930635	104 Link 3/4" Wide BorgWarner
930636	106 Link 3/4" Wide BorgWarner



### Don't Forget Your Chaincase Oil!

Part #936000, 12oz. Venom Products chaincase oil is specifically formulated for use with billet case carburized sprockets, also meets or exceeds all OEM specifications for OEM sprockets.

Part No.	Description
930407	66 Link 13W Rexnord Silent Chain
930408	68 Link 13W Rexnord Silent Chain
930409	70 Link 13W Rexnord Silent Chain
930410	72 Link 13W Rexnord Silent Chain
930411	74 Link 13W Rexnord Silent Chain
930412	76 Link 13W Rexnord Silent Chain
970417	78 Link 13W Rexnord Silent Chain
970413	80 Link 13W Rexnord Silent Chain
970414	82 Link 13W Rexnord Silent Chain
970415	84 Link 13W Rexnord Silent Chain
970416	86 Link 13W Rexnord Silent Chain
970418	88 Link 13W Rexnord Silent Chain
970423	90 Link 13W Rexnord Silent Chain
970422	100 Link 13W Rexnord Silent Chain
970419	102 Link 13W Rexnord Silent Chain
970420	104 Link 13W Rexnord Silent Chain
970421	106 Link 13W Rexnord Silent Chain
970424	110 Link 13W Rexnord Silent Chain
970425	112 Link 13W Rexnord Silent Chain



# CHAINS & SPROCKETS

To get optimal performance out of your machine, you need to gear it right. We offer a complete lineup of gears to fit your needs. Made of heat treated, case-hardened 8620 high-alloy steel, our CNC-machined sprockets are made in an ISO 9000 certified facility right here in the United States.



POLARIS	STOCK		Chain
	Top	Bottom	
1998-Up All Two Stroke (except below)	351352	930261-930271, 930626-930628	HY-VO® 13W
1999 Indy 340	351513	351518	Rexnord® 13W
1998 Indy Lite, Lite Touring, XLT Touring	351513	351518	Rexnord® 13W
1997 Liquid Cooled	351513	351518	Rexnord® 13W
1997 Fan Cooled	351573	351574	Rexnord® 11W
1996 RXL, Storm, Ultra ,XCR 600 SP, XCR 440, XLT	351513	351518	Rexnord® 13W
1996 All Others	351573	351574	Rexnord® 11W
1993-95 RXL, Storm, XCR 440, XLT	351513	351518	Rexnord® 13W
1993-95 All Others	351573	351574	Rexnord® 11W
Pre 1992	351573	351574	Rexnord® 11W



## VENOM™ BILLET OEM REPLACEMENT SPROCKETS

Polaris has used HY-VO® chains in most of their performance models since 1998. If you have an earlier machine, you can also upgrade to HY-VO® sprockets and chains. (See chart above).

### TOP SPROCKETS

Part No.	Description
<b>POLARIS HY-VO® 3/4" Top Sprockets</b>	
351352-001	16T Sprocket, 15T Internal
351352-002	17T Sprocket, 15T Internal
351352-003	18T Sprocket, 15T Internal
351352-004	19T Sprocket, 15T Internal
351352-005	20T Sprocket, 15T Internal
351352-006	21T Sprocket, 15T Internal
351352-007	22T Sprocket, 15T Internal
351352-008	23T Sprocket, 15T Internal
351352-009	24T Sprocket, 15T Internal
351352-010	25T Sprocket, 15T Internal
351352-011	26T Sprocket, 15T Internal
<b>POLARIS Rexnord® Top 13W Sprockets</b>	
351513-001	16T Sprocket, 13T Internal
351513-002	17T Sprocket, 13T Internal
351513-003	18T Sprocket, 13T Internal
351513-004	19T Sprocket, 13T Internal
351513-005	20T Sprocket, 13T Internal
351513-006	21T Sprocket, 13T Internal
351513-007	22T Sprocket, 13T Internal
351513-008	23T Sprocket, 13T Internal
351513-009	24T Sprocket, 13T Internal
351513-010	25T Sprocket, 13T Internal

Part No.	Description
<b>POLARIS Top 11W Sprockets</b>	
351573-007	22T Sprocket, 13T Internal

### BOTTOM SPROCKETS

Part No.	Description
<b>POLARIS HY-VO® 3/4" Bottom Sprockets</b>	
930261	33T Sprocket, 15T Internal
930262	34T Sprocket, 15T Internal
930263	35T Sprocket, 15T Internal
930264	36T Sprocket, 15T Internal
930265	37T Sprocket, 15T Internal
930266	38T Sprocket, 15T Internal
930267	39T Sprocket, 15T Internal
930268	40T Sprocket, 15T Internal
930269	41T Sprocket, 15T Internal
930270	42T Sprocket, 15T Internal
930271	43T Sprocket, 15T Internal
930626	44T Sprocket, 15T Internal
930627	45T Sprocket, 15T Internal
930628	46T Sprocket, 15T Internal

Part No.	Description
<b>POLARIS Rexnord® Bottom 13W Sprockets</b>	
351518-001	33T Sprocket, 15T Internal
351518-002	34T Sprocket, 15T Internal
351518-003	35T Sprocket, 15T Internal
351518-004	36T Sprocket, 15T Internal
351518-005	37T Sprocket, 15T Internal
351518-006	38T Sprocket, 15T Internal
351518-007	39T Sprocket, 15T Internal
351518-008	40T Sprocket, 15T Internal
351518-009	41T Sprocket, 15T Internal
351518-010	42T Sprocket, 15T Internal
351518-011	43T Sprocket, 15T Internal



**Don't Forget Your Chaincase Oil!**

Part #936000, 12oz. \$9.90  
Venom Products chaincase oil is specifically formulated for use with billet case carburized sprockets, also meets or exceeds all OEM specifications for OEM sprockets.



# CHAINS & SPROCKETS

To get optimal performance out of your machine, you need to gear it right. We offer a complete lineup of gears to fit your needs. Made of heat treated, case-hardened 8620 high-alloy steel, our CNC-machined sprockets are made in an ISO 9000 certified facility right here in the United States.



SKI-DOO	STOCK		
	Top	Bottom	Chain
2008-Up XP/XM Chassis (Two Stroke)	351519	352666	Rexnord® 13W
2011-Up XR Chassis (Four Stroke)	13W OEM	352666	Rexnord® 13W
1993-2007 Rev/CK3/S2000/F2000 Chasis	351519	351520	Rexnord® 13W
All Others	351519	351520	Rexnord® 13W

**NOTE:** See Page 19 for Hy-Vo conversion upgrades.

## VENOM™ BILLET OEM REPLACEMENT SPROCKETS

To get optimal performance out of your machine, you need to gear it right. We offer a complete lineup of gears to fit your needs. Made of heat treated, case-hardened 8620 high-alloy steel, our CNC-machined sprockets are made in an ISO 9000 certified facility right here in the United States.



### TOP SPROCKETS

Part No.	Description
<b>SKI-DOO Top 13W Sprockets F/S/CK3/Rev/XP/XM/Gen 4 Chassis</b>	
351519-013	17T Sprocket, 15T Internal
351519-001	18T Sprocket, 15T Internal
351519-002	19T Sprocket, 15T Internal
351519-003	20T Sprocket, 15T Internal
351519-004	21T Sprocket, 15T Internal
351519-005	22T Sprocket, 15T Internal
351519-006	23T Sprocket, 15T Internal
351519-007	24T Sprocket, 15T Internal
351519-008	25T Sprocket, 15T Internal
351519-009	26T Sprocket, 15T Internal
351519-010	27T Sprocket, 15T Internal
351519-011	28T Sprocket, 15T Internal
351519-012	29T Sprocket, 15T Internal

Part No.	Description
<b>SKI-DOO Bottom 13W Sprockets F/S/CK3/Rev Chassis</b>	
351520-002	39T Sprocket, 17T Internal
351520-003	40T Sprocket, 17T Internal
351520-006	43T Sprocket, 17T Internal
351520-007	44T Sprocket, 17T Internal
351520-008	45T Sprocket, 17T Internal
351520-009	46T Sprocket, 17T Internal
351520-010	47T Sprocket, 17T Internal
351520-011	48T Sprocket, 17T Internal
351520-012	49T Sprocket, 17T Internal

### BOTTOM SPROCKETS

<b>SKI-DOO Bottom 13W Sprockets XP/XR/XM/Gen 4 Chassis</b>	
352666-08	36T Sprocket, 32T Internal
352666-10	38T Sprocket, 32T Internal
352666-12	40T Sprocket, 32T Internal
352666-13	41T Sprocket, 32T Internal
352666-14	42T Sprocket, 32T Internal
352666-01	43T Sprocket, 32T Internal
352666-02	44T Sprocket, 32T Internal
352666-03	45T Sprocket, 32T Internal
352666-04	46T Sprocket, 32T Internal
352666-05	47T Sprocket, 32T Internal
352666-06	48T Sprocket, 32T Internal
352666-07	49T Sprocket, 32T Internal
352666-15	50T Sprocket, 32T Internal
352666-16	51T Sprocket, 32T Internal



**DRIVE CHAINS**  
Rexnord® Silent Chains for use with Rexnord 13W sprockets.

Part No.	Description
930407	66 Link 13W Rexnord Silent Chain
930408	68 Link 13W Rexnord Silent Chain
930409	70 Link 13W Rexnord Silent Chain
930410	72 Link 13W Rexnord Silent Chain
930411	74 Link 13W Rexnord Silent Chain
930412	76 Link 13W Rexnord Silent Chain
970417	78 Link 13W Rexnord Silent Chain
970413	80 Link 13W Rexnord Silent Chain
970414	82 Link 13W Rexnord Silent Chain
970415	84 Link 13W Rexnord Silent Chain
970416	86 Link 13W Rexnord Silent Chain
970418	88 Link 13W Rexnord Silent Chain
970423	90 Link 13W Rexnord Silent Chain
970422	100 Link 13W Rexnord Silent Chain
970419	102 Link 13W Rexnord Silent Chain
970420	104 Link 13W Rexnord Silent Chain
970421	106 Link 13W Rexnord Silent Chain
970424	110 Link 13W Rexnord Silent Chain
970425	112 Link 13W Rexnord Silent Chain

# SKI-DOO HY-VO® CONVERSION SPROCKETS

Upgrade your Ski-Doo with a set of HY-VO® conversion sprockets and chain. HY-VO® sprockets must be used with a HY-VO® chain.

**ski-doo**



## TOP SPROCKETS

Part No.	Description
<b>SKI-DOO HY-VO® 3/4" Top Sprockets F/S/CK3/Rev/XP/XM Chassis</b>	
351363-001	18T Sprocket, 15T Internal
351363-002	19T Sprocket, 15T Internal
351363-003	20T Sprocket, 15T Internal
351363-004	21T Sprocket, 15T Internal
351363-005	22T Sprocket, 15T Internal
351363-006	23T Sprocket, 15T Internal
351363-007	24T Sprocket, 15T Internal
351363-008	25T Sprocket, 15T Internal
351363-009	26T Sprocket, 15T Internal



## BOTTOM SPROCKETS

Part No.	Description
<b>SKI-DOO HY-VO® 3/4" Bottom Sprockets XP/XM Chassis</b>	
931033-001	45T Sprocket, 32T Internal
931033-002	46T Sprocket, 32T Internal
931033-003	47T Sprocket, 32T Internal
931033-004	48T Sprocket, 32T Internal
931033-005	49T Sprocket, 32T Internal
931033-006	50T Sprocket, 32T Internal
931033-007	51T Sprocket, 32T Internal
<b>SKI-DOO HY-VO® 3/4" Bottom Sprockets F/S/CK3/Rev Chassis</b>	
351364-001	38T Sprocket, 17T Internal
351364-002	39T Sprocket, 17T Internal
351364-003	40T Sprocket, 17T Internal
351364-004	41T Sprocket, 17T Internal
351364-005	42T Sprocket, 17T Internal
351364-008	45T Sprocket, 17T Internal
351364-010	47T Sprocket, 17T Internal



## DRIVE CHAINS

3/4" BorgWarner HY-VO® chains for use with all HY-VO® 3/4" sprockets.

Part No.	Description
930219	68 Link 3/4" Wide BorgWarner
930220	70 Link 3/4" Wide BorgWarner
930221	72 Link 3/4" Wide BorgWarner
930222	74 Link 3/4" Wide BorgWarner
930223	76 Link 3/4" Wide BorgWarner
930300	78 Link 3/4" Wide BorgWarner
930686	80 Link 3/4" Wide BorgWarner
930301	82 Link 3/4" Wide BorgWarner
930302	84 Link 3/4" Wide BorgWarner
930303	86 Link 3/4" Wide BorgWarner
930304	88 Link 3/4" Wide BorgWarner
930633	90 Link 3/4" Wide BorgWarner
930634	92 Link 3/4" Wide BorgWarner
930305	94 Link 3/4" Wide BorgWarner
930306	96 Link 3/4" Wide BorgWarner
930307	98 Link 3/4" Wide BorgWarner
930308	100 Link 3/4" Wide BorgWarner
930309	102 Link 3/4" Wide BorgWarner
930635	104 Link 3/4" Wide BorgWarner
930636	106 Link 3/4" Wide BorgWarner



### Don't Forget Your Chaincase Oil!

Part #936000, 12oz. Venom Products chaincase oil is specifically formulated for use with billet case carburized sprockets, also meets or exceeds all OEM specifications for OEM sprockets.



# CHAINS & SPROCKETS

To get optimal performance out of your machine, you need to gear it right. We offer a complete lineup of gears to fit your needs. Made of heat treated, case-hardened 8620 high-alloy steel, our CNC-machined sprockets are made in an ISO 9000 certified facility right here in the United States.



### Don't Forget Your Chaincase Oil!

Part #936000, 12oz. \$9.90  
Venom Products chaincase oil is specifically formulated for use with billet case carburized sprockets, also meets or exceeds all OEM specifications for OEM sprockets.

YAMAHA	STOCK		Chain
	Top	Bottom	
2014-Up SR Viper/Sidewinder	422315	931076	HY-VO® 3/4"
2008-14 Apex, FX Nytro, Vector, Venture, VK Pro	351361	13W OEM	HY-VO® 3/4"
2004-07 Non Reverse	351361	930261-930271, 930626-930628	HY-VO® 3/4"
2004-07 With Reverse	351361	13W OEM	HY-VO® 3/4"
1997-2003 VX, VT, MM, SX	351517	351518	Rexnord® 13W
2000-02 VMAX, SRX	351361	931076	HY-VO® 3/4"

## VENOM™ BILLET OEM REPLACEMENT SPROCKETS

To get optimal performance out of your machine, you need to gear it right. We offer a complete lineup of gears to fit your needs. Made of heat treated, case-hardened 8620 high-alloy steel, our CNC-machined sprockets are made in an ISO 9000 certified facility right here in the United States.



### TOP SPROCKETS

Part No.	Description
<b>YAMAHA HY-VO® 3/4" Top Sprockets</b>	
351361-003	18T Sprocket, 16T Internal
351361-004	19T Sprocket, 16T Internal
351361-006	21T Sprocket, 16T Internal
351361-007	22T Sprocket, 16T Internal
351361-008	23T Sprocket, 16T Internal
351361-009	24T Sprocket, 16T Internal
<b>YAMAHA Viper SR HY-VO® 3/4" Top Sprockets</b>	
422315-006	21T Sprocket, 33T Engagement
422315-007	22T Sprocket, 33T Engagement
422315-008	23T Sprocket, 33T Engagement
422315-009	24T Sprocket, 33T Engagement
422315-010	25T Sprocket, 33T Engagement
422315-011	26T Sprocket, 33T Engagement
422315-012	27T Sprocket, 33T Engagement
422315-013	28T Sprocket, 33T Engagement
<b>YAMAHA HY-VO® 3/4" Top Sprockets</b>	
351478-001	16T Sprocket, 15T Internal
351478-002	17T Sprocket, 15T Internal
351478-003	18T Sprocket, 15T Internal
351478-004	19T Sprocket, 15T Internal
351478-005	20T Sprocket, 15T Internal
351478-006	21T Sprocket, 15T Internal
351478-007	22T Sprocket, 15T Internal
351478-008	23T Sprocket, 15T Internal

Part No.	Description
<b>YAMAHA Top 13W Sprockets</b>	
351517-001	17T Sprocket, 15T Internal
351517-002	18T Sprocket, 15T Internal
351517-003	19T Sprocket, 15T Internal
351517-004	20T Sprocket, 15T Internal
351517-005	21T Sprocket, 15T Internal
351517-006	22T Sprocket, 15T Internal
351517-007	23T Sprocket, 15T Internal
351517-008	24T Sprocket, 15T Internal
351517-009	25T Sprocket, 15T Internal

Part No.	Description
<b>YAMAHA Viper SR HY-VO® 3/4" Bottom Sprockets</b>	
931076-005	42T Sprocket, 34T Internal
931076-006	43T Sprocket, 34T Internal
931076-007	44T Sprocket, 34T Internal
931076-008	45T Sprocket, 34T Internal
931076-009	46T Sprocket, 34T Internal
931076-010	47T Sprocket, 34T Internal
931076-011	48T Sprocket, 34T Internal
931076-012	49T Sprocket, 34T Internal
931076-013	50T Sprocket, 34T Internal

### BOTTOM SPROCKETS

Part No.	Description
<b>YAMAHA HY-VO® 3/4" Bottom Sprockets</b>	
930250	33T Sprocket, 15T Internal
930251	34T Sprocket, 15T Internal
930252	35T Sprocket, 15T Internal
930253	36T Sprocket, 15T Internal
930254	37T Sprocket, 15T Internal
930255	38T Sprocket, 15T Internal
930256	39T Sprocket, 15T Internal
930257	40T Sprocket, 15T Internal
930258	41T Sprocket, 15T Internal
930259	42T Sprocket, 15T Internal
930260	43T Sprocket, 15T Internal

<b>YAMAHA Bottom 13W Sprockets</b>	
351518-001	33T Sprocket, 15T Internal
351518-002	34T Sprocket, 15T Internal
351518-003	35T Sprocket, 15T Internal
351518-004	36T Sprocket, 15T Internal
351518-005	37T Sprocket, 15T Internal
351518-006	38T Sprocket, 15T Internal
351518-007	39T Sprocket, 15T Internal
351518-008	40T Sprocket, 15T Internal
351518-009	41T Sprocket, 15T Internal
351518-010	42T Sprocket, 15T Internal
351518-011	43T Sprocket, 15T Internal

# DRIVE CHAINS



3/4" BorgWarner HY-VO™ Chains - For use with all Venom HY-VO™ 3/4 inch sprockets.

Part No.	Description
930219	68 Link 3/4" Wide BorgWarner
930220	70 Link 3/4" Wide BorgWarner
930221	72 Link 3/4" Wide BorgWarner
930222	74 Link 3/4" Wide BorgWarner
930223	76 Link 3/4" Wide BorgWarner
930300	78 Link 3/4" Wide BorgWarner
930686	80 Link 3/4" Wide BorgWarner
930301	82 Link 3/4" Wide BorgWarner
930302	84 Link 3/4" Wide BorgWarner
930303	86 Link 3/4" Wide BorgWarner
930304	88 Link 3/4" Wide BorgWarner
930633	90 Link 3/4" Wide BorgWarner
930634	92 Link 3/4" Wide BorgWarner
930305	94 Link 3/4" Wide BorgWarner
930306	96 Link 3/4" Wide BorgWarner
930307	98 Link 3/4" Wide BorgWarner
930308	100 Link 3/4" Wide BorgWarner
930309	102 Link 3/4" Wide BorgWarner
930635	104 Link 3/4" Wide BorgWarner
930636	106 Link 3/4" Wide BorgWarner



Rexnord® Silent Chains for use with Rexnord 13W sprockets.

Part No.	Description
930407	66 Link 13W Rexnord Silent Chain
930408	68 Link 13W Rexnord Silent Chain
930409	70 Link 13W Rexnord Silent Chain
930410	72 Link 13W Rexnord Silent Chain
930411	74 Link 13W Rexnord Silent Chain
930412	76 Link 13W Rexnord Silent Chain
970417	78 Link 13W Rexnord Silent Chain
970413	80 Link 13W Rexnord Silent Chain
970414	82 Link 13W Rexnord Silent Chain
970415	84 Link 13W Rexnord Silent Chain
970416	86 Link 13W Rexnord Silent Chain
970418	88 Link 13W Rexnord Silent Chain
970423	90 Link 13W Rexnord Silent Chain
970422	100 Link 13W Rexnord Silent Chain
970419	102 Link 13W Rexnord Silent Chain
970420	104 Link 13W Rexnord Silent Chain
970421	106 Link 13W Rexnord Silent Chain
970424	110 Link 13W Rexnord Silent Chain
970425	112 Link 13W Rexnord Silent Chain

## FORMULA TO CALCULATE CHAIN LENGTH

$$(5.333 \times CD) + [(TS + BS) / 2] + [(BS - TS)^2 / 105.3 / CD] = \text{Pitch}$$

CD = Center Distance (drive shaft to jackshaft)

TS = Top Sprocket

BS = Bottom Sprocket

Round number up to even number for proper pitch.

Arctic Cat Models	CD (inches)	Yamaha Models	CD (inches)
All models	7.5	All models	7
Proclimb/Procross	10.160	SR Viper	10.160
2017-Up Drop Case	11.375		

Note: The tensioner in the new AC chassis will only allow certain combinations

Polaris Models	CD (inches)	Ski-Doo Models	CD (inches)
1996 & Older	6.63	CK3 Chassis	6.85
1997-2001 Gen II	7.05	ZX & REV	7.48
2006-07 All Fusion & RMK	8.37	RT Mach	7.97
All Edge & 440 IQ race sleds	7.92	RT Summit	9.19
Pro, Rush & 13 up Indy	7.53	REV XP	12.85
Axys, XCR, Switchback, Assault	7.063	Summit 850	14.92
RMK Axys 3"	7.764		

## FORMULA TO CALCULATE MPH

$$\text{MPH} = \frac{\text{Engine RPM}}{\text{Clutch Ratio}} \times \frac{\text{Teeth(Top Sprocket)}}{\text{Teeth(Bottom Sprocket)}} \times \frac{(\text{Pitch of Track} \times \# \text{ of teeth on Drive Sprocket})}{12} \times \frac{60}{5280}$$





# TEAM® TIED CLUTCH SERVICE PARTS

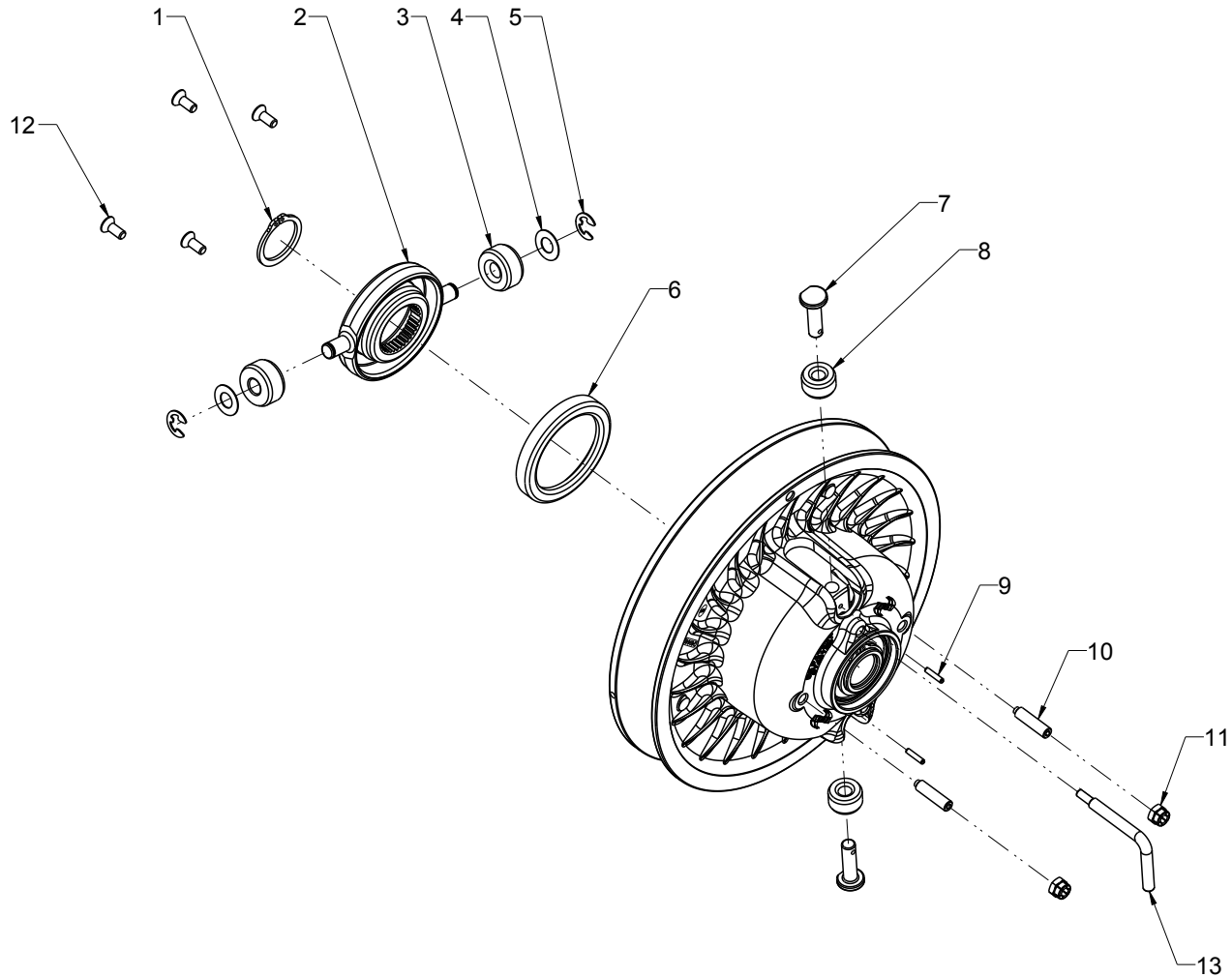

**PARTS NOT LISTED ON THIS DIAGRAM ARE NON-SERVICEABLE AND ARE NOT AVAILABLE FOR SALE.**

Diagram #	Part #	Quantity	Description
1	130101	2	Ring, Retaining Basic External 1.375
2	N/A	1	Spider, 35T Mach
3	460125	2	Roller, Clutch
4	N/A	1	Washer, Thrust
5	130123	2	Ring, Retaining E-Ring External
6	430063	1	Spring Cup
7	N/A	1	Pin, Roller
8	460079	2	Roller, Clutch
9	125037	2	Pin, Spring Slotted
10	105307	2	Screw, Set Hex Skt 5/16-24 x 1.25
11	110083	2	Nut, Lock Hex - Flexloc
12	105229K	1	Screws, Helix Torx T27 (Set of 4)
13	650343	1	Belt Removal Tool (Tied)
	990500		Ski-Doo/Nytro floater plug
	150216		Alignment Spacer .985 X .360 X 1.10
	150253		Alignment Washer, 1.38 X 1.02 X .03
	930194TD		Tool Kit, Arctic Cat Tied Clutch
	930193TD		Tool Kit, Polaris Tied Clutch
	930196TD		Tool Kit, Ski-Doo Tied Clutch
	930195TD		Tool Kit, Yamaha Tied Clutch

## TEAM® TSS-04 CLUTCH SERVICE PARTS

PARTS NOT LISTED ON THIS DIAGRAM ARE NON-SERVICEABLE AND ARE NOT AVAILABLE FOR SALE.

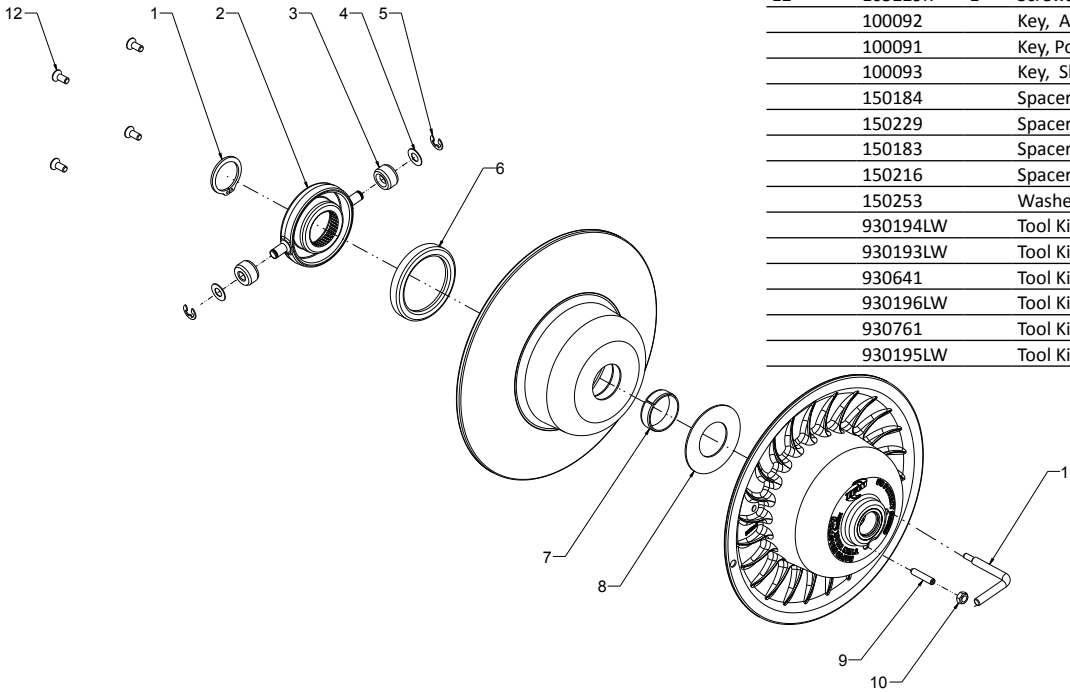

Diagram #	Part #	Qty.	Description
1	130101	2	Ring, Retaining Basic External 1.375
2	N/A	1	Spider, 35T 10.75 Mach
3	460079	2	Roller, Clutch
4	150151	2	Washer, Thrust
5	130059	2	Ring, Retaining E-Ring External .375
6	430063	1	Spring Cup
7	180130	1	Bushing, Moveable sheave 10.75
8	150229	1	Spacer, 1.510 ID x 2.950 OD x .062
9	105210	1	Screw, Set Hex Skt 1/4-20 x 1.25
10	110053	1	Nut, Lock Hex 1/4-20 Crownlock
11	930002	1	Belt Removal Tool for Tied Clutch
12	105229K	1	Screws, Helix Torx T27 (Set of 4)
	100092		Key, Arctic Cat, TSS-04
	100091		Key, Polaris TSS-04
	100093		Key, Ski-Doo, 25 mm Shaft,
	150184		Spacer .985x.36x1.85 Arctic Cat TSS-04
	150229		Spacer TSS-04
	150183		Spacer .83x.58x1.81 Yamaha TSS-04
	150216		Spacer .985 X .360 X 1.10
	150253		Washer, 1.38 X 1.02 X .03
	930194LW		Tool Kit, Arctic Cat TSS-04
	930193LW		Tool Kit, Polaris TSS-04
	930641		Tool Kit, Polaris Splined, TSS-04
	930196LW		Tool Kit, Ski-Doo TSS-04
	930761		Tool Kit, Ski-Doo TSS-04 25 mm
	930195LW		Tool Kit, Yamaha TSS-04

## TEAM® TSS-98 CLUTCH SERVICE PARTS

PARTS NOT LISTED ON THIS DIAGRAM ARE NON-SERVICEABLE AND ARE NOT AVAILABLE FOR SALE.

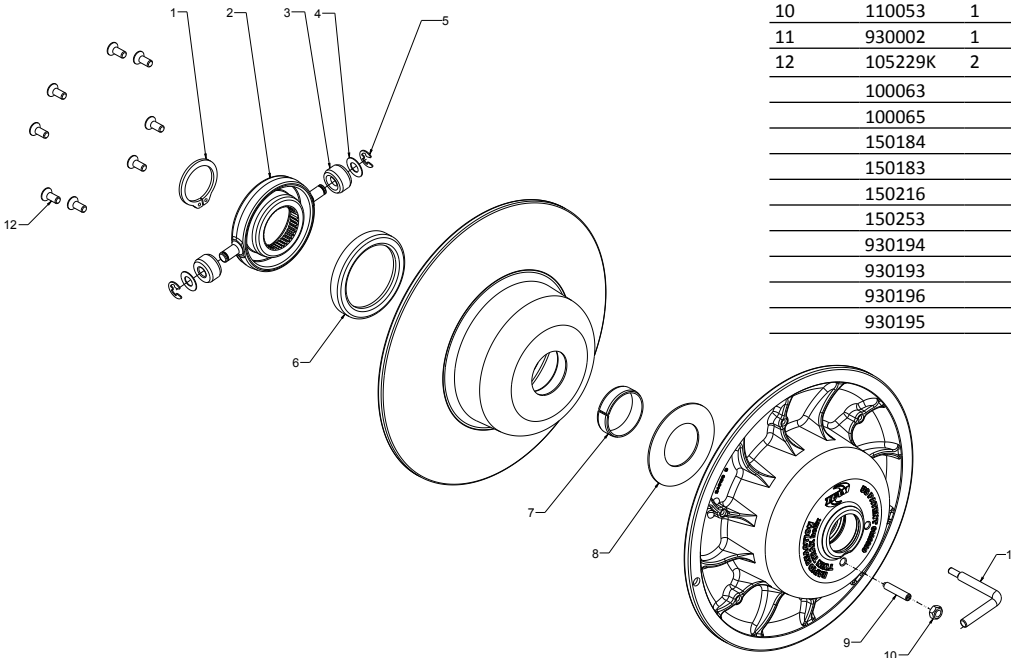

Diagram #	Part #	Qty.	Description
1	130032	1	Ring, Retaining Basic External 1.500
2	N/A	1	Spider, 38T 10.75 Mach
3	460079	2	Roller, Clutch
4	150151	2	Washer, Thrust
5	130059	2	Ring, Retaining E-Ring External .375
6	430063	1	Spring Cup
7	180165	1	Bushing, Moveable Sheave 10.75
8	150175	1	Spacer
9	105210	1	Screw, Set Hex Skt 1/4-24 x 1.25
10	110053	1	Nut, Lock Hex -1/4-20 UNC Crownlock
11	930002	1	Belt Removal Tool
12	105229K	2	Screws, Helix Torx T27 (Set of 4)
	100063		Key, .25 Square Polaris TSS-98
	100065		Key, Arctic Cat TSS-98
	150184		Spacer .985x.36x1.85 Arctic Cat TSS-98
	150183		Spacer .83x.58x1.81 Yamaha TSS-98
	150216		Spacer .985 X .360 X 1.10
	150253		Washer, 1.38 X 1.02 X .03
	930194		Tool Kit, Arctic Cat TSS-98
	930193		Tool Kit, Polaris TSS-98
	930196		Tool Kit, Ski-Doo TSS-98
	930195		Tool Kit, Yamaha TSS-98

Learn more about powersports drivetrain and transmission parts we have.