

The image shows a close-up of a dark, textured surface, possibly a car floor mat or a piece of equipment. A black rectangular label is affixed to the surface, featuring the "WeatherTech" logo. The word "Weather" is in white, and "Tech" is in red. A registered trademark symbol (®) is located at the end of the word "Tech". The background has a repeating pattern of raised, rounded rectangular shapes.

WeatherTech®

2010 Product Use Guide

What Matters to You?

Today, America needs fresh leadership to lead us as a nation out of this economic crisis. Leadership must come not only from our political leaders but also from the average citizen. The exporting of American jobs is a trend that must be stopped and reversed. When I walk into my local hardware store, I typically find 85% of the goods for sale are manufactured 7,000 miles away. Recognizable American brands have been forced by shortsighted management and buyers at large national chains to build factories overseas just to save a lousy \$.50 on a tape measure. To these ruthless buyers, it is all about the money. Rarely are product quality, the political system, human rights, animal rights and environmental costs to the planet considered, not to mention the cost to our society of exporting not only jobs, but an entire factory!

At MacNeil Automotive, we are doing our part for the American economy and for our 300 million fellow citizens and neighbors. My philosophy is that if my neighbor doesn't have a job, sooner or later I won't have a job either. For example, we used to have our All-Weather Floor Mats manufactured in England by a company that used antiquated, inefficient equipment. They made a decent floor mat for us, but we thought we could build a better floor mat for our customers using modern American technology, American raw materials and skilled American workers. So in 2007 we transferred all of our floor mat manufacturing back to the United States. Today, we build the best fitting, highest quality automotive floor mats in the world, right here in America.

Our machine shop is equipped with 17 CNC machining centers including four 4 axis mills and one 5 axis mill that produce between 30 to 50 injection and thermoforming molds per month. We have one shift of highly skilled American Journeymen toolmakers and apprentices, but our machines run 24 hours a day, 7 days a week. There is not a more efficient tool and mold making operation in the world - and guess what, it's right here in America.



Furthermore, all of our CNC mills are manufactured in Oxnard, CA by Haas. Our 1,000 ton injection molding machines are made in Bolton, Ontario of American and Canadian components. Our thermoforming machinery is made in Carol Stream, IL. The raw steel and aluminum billets which make up our tooling are sourced from American steel and aluminum mills such as Vista Metals in Fontana, CA. The raw materials that make up our All-Weather Floor Mats, FloorLiners, Cargo Liners and Mud Flaps are manufactured in Bellevue OH, Arlington TX, Wichita KS and Jasper TN. Our forklifts are made in Columbus IN and Greene NY. Our warehouse racking is manufactured in Tatamy PA.

At MacNeil Automotive, we are also very aware of sustainability and our responsibility to the environment. We are proactive in controlling waste and recycling all of the unused raw materials from the manufacture of our tooling and products including: aluminum, steel, rubber, TPO, TPE, paper and cardboard.

As you can see, we are as dedicated to designing, developing and manufacturing the finest automotive accessories for our consumer and OEM clients as we are passionate about supporting the American economy, preserving the American industrial infrastructure, and keeping the "money" in our family, a family of 300 million people from all over America.

Life is simple; be good to your fellow man, be kind to animals and the environment, and place building a quality product, supporting your country and your fellow American worker before profit. And, one last thing - let's all do our best to balance family time with work time as our children are the future of America.

Sincerely,



WeatherTech®





Content

- 4 FloorLiner™**
extreme-duty floor protection
- 8 All-Weather Floor Mats**
premium all-weather mats
- 12 Cargo Liners**
computer designed cargo protection
- 16 Side Window Deflectors**
let the fresh air in®
- 20 MudFlap**
premium no-drill mud flap
- 24 ClearCover®, ClearFrame™, PlateFrame™**
license plate accessories
- 28 Sunroof Wind Deflector™**
let the fresh air in®
- 32 Easy-On® Stone & Bug Deflector**
complete front end protection
- 36 AVM™ Universal Cargo Mat**
all vehicle trim-to-fit™ cargo mat
- 38 TechShade™**
perfect for any season
- 40 RackSack®**
expand your cargo capacity
- 42 Pet Barrier**
expandable, extendable pet barrier
- 44 LampGard™**
simple headlamp protection

WeatherTech®

FloorLiner™



Audi A4 shown



Texture



Raised Lip



Contoured Underside

Extreme-Duty Floor Protection

Rear Over the Hump FloorLiner™



Ford Taurus shown



Toyota Camry shown

- Provides “absolute interior protection™”
- Channels to carry fluids and debris to a lower reservoir
- Available for popular trucks, SUVs, cars and minivans
- High Density Tri-Extruded (HDTE) material provides soft touch top, rigid core strength and bottom surface friction
- Available in Black, Tan and Gray



WeatherTech®

FloorLiner™



General Installation Instructions

Important: You must remove your existing floor mats before installation of your new WeatherTech® FloorLiner™.

You have just purchased the finest all weather protection available for your vehicle's interior. The WeatherTech® FloorLiner™ is designed to assure a perfect fit in your specific vehicle. To get the best performance possible from this product, please be sure to follow these instructions:

To install the FloorLiner™, please remove the original carpet floor mat prior to installation. Do not place your new FloorLiner™ on top of any existing carpet, plastic, or rubber mat. Your new FloorLiner™ is designed to be placed directly on the original carpet floor of the vehicle, utilizing the factory retention kit, where provided. Failure to follow these instructions could create an unsafe situation if the FloorLiner™ were to move and interfere with the safe operation of the clutch, brake or accelerator pedal.

Prior to driving your vehicle, please confirm that the FloorLiner™ DOES NOT INTERFERE with the safe operation of the accelerator, brake and clutch pedals. Please move each pedal through its respective full range of motion noting any interference. If there is any interference, remove the FloorLiner™ before driving. **Never operate the vehicle if the FloorLiner™ could possibly interfere with its safe operation.**

Regular cleaning extends the life of your FloorLiner™. The FloorLiner™ should be removed and shaken regularly to remove liquid and loose debris. Clean your FloorLiner™ using only a mild detergent soap and water. Do not use harsh chemicals or abrasive type cleaners as these products may damage the product. We do not recommend Armor All® or STP Son-of-a-Gun, as these types of products make the FloorLiner™ slippery.

Important Safety Tips

1. Before starting and driving make sure that the FloorLiner™ does not in any way interfere with the safe operation of this vehicle.
2. Before driving make sure that the FloorLiner™ does not in any way interfere with the accelerator pedal, brake pedal or clutch pedal.
3. Make sure that all drivers of this vehicle are aware of these safety tips.

All-Weather Floor Mats

- Deep sculpted channels to trap and contain water, road salt, mud and sand
- Will not crack, curl or harden regardless of temperature
- Environmentally safe, 100% recyclable non toxic material
- Available for virtually any car, SUV, minivan or light truck



Ribbed Design

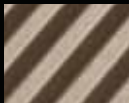

Fluid and Debris Reservoir



Underside - Nibs and Anti-Skid Ridges



Premium Floor Mats



Chevrolet Tahoe shown



Hyundai Sonata shown



*Proudly Designed,
Engineered and
Manufactured with
American made
tooling in the USA*

WeatherTech®

All-Weather Floor Mats



Fitting Instruction

Your WeatherTech® All-Weather Floor Mats were intended to give the best possible protection for your vehicle floor. Many of our front mat applications are vehicle specific, while others are determined to be the best possible fit for the application from our many shapes and sizes.

Our rear floor mats are designed with score lines that allow for trimming where necessary to provide the best fit possible with the greatest coverage. The mats are not marked left or right, but the contour should match the outline of the vehicle floor, or be close to the original carpet mats that you have removed.

Please ensure that the front drivers side mat fits correctly and in a manner that does not impede travel of the accelerator, brake, or clutch pedal. **If there is ANY possibility for interference, please do not operate the vehicle until the cause and remedy is determined.**

If the vehicle is equipped with retention devices or anchors, please use them and be certain to NEVER put your All-Weather Floor Mats on top of any other vehicle mat. Only place on top of the original vehicle carpet floor.

Regular cleaning extends the life of your All-Weather Floor Mats. The floor mats should be removed and shaken regularly to remove liquid and loose debris. Clean your All-Weather Floor Mats using only a mild detergent soap and water. Do not use harsh chemicals or abrasive type cleaners as these products may damage the product. We do not recommend Armor All® or STP Son-of-a-Gun, as these types of products make the All-Weather Floor Mats slippery.

Important Safety Tips

1. Before starting and driving make sure that the mats do not in any way interfere with the safe operation of this vehicle.
2. Before driving make sure that the mats do not in any way interfere with the accelerator pedal, brake pedal or clutch pedal.
3. Make sure that all drivers of this vehicle are aware of these safety tips.

WeatherTech®

Cargo Liners

- Complete trunk and cargo area protection
- Digitally designed for each application
- Remains flexible under temperature extremes
- Available for car trunks, SUVs and minivans



DigitalFit™
WeatherTech®
Cargo Liners



Computer Designed Protection



GMC Yukon shown



Toyota Venza shown



Textured Finish



Raised Lip, Custom Design



**Proudly Designed,
Engineered and
Manufactured with
American made
tooling in the USA**

WeatherTech®

Cargo Liners

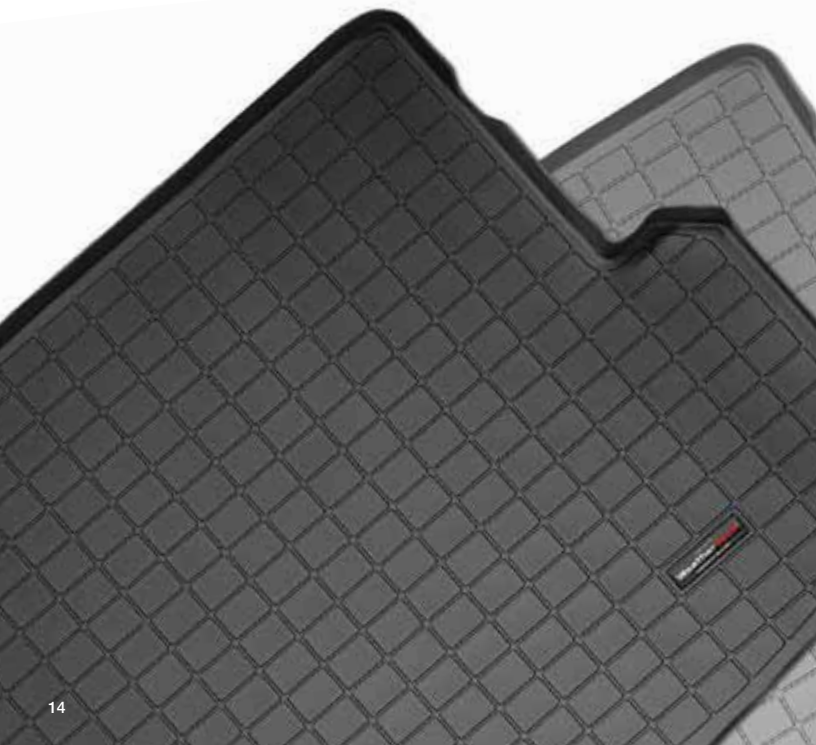

Fitting Instruction

Your new WeatherTech® Cargo Liner is custom molded to fit your particular vehicle. Upon removal from the box you will notice that the liner may not completely unroll and lie flat. This is normal and only temporary. Just place the liner on the floor or in the back of your vehicle and put a weight in each corner (a book works well). After about 15 minutes your liner will remain flat.

Your liner is made from an engineered resin that is both lightweight and extremely durable. The easiest way to clean your liner is with a damp cloth or sponge. If using a cleaner, 409® or Glass Plus® work well. We do not recommend Armor-All® or STP Son-of-a-Gun® as these types of products make the liner slick and cargo will slide.

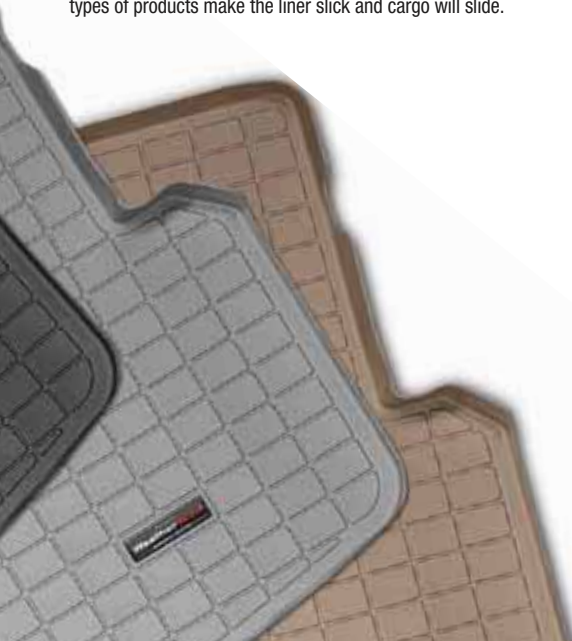

WeatherTech®

Side Window Deflectors

They Just
Snap Right In!



Chrysler Town & Country shown

- Increased ventilation
- Allow interior heat to escape
- Made from finest 3mm lightly tinted acrylic material
- Installs easily with No Exterior Tape Needed
- Designed in USA, handcrafted in Germany



Available in
Light & Dark Tint

Let The Fresh Air In[®]



Dodge Ram shown



Toyota Corolla shown (Dark Tint)

- Available for some applications in a dark tint
- The darker tint is similar to that of quality sunglasses

WeatherTech®

Side Window Deflectors

*Please see specific
installation instructions
in your package.*



General Installation Instructions

1. Please begin installation with drivers side window. Insert the deflectors leading vertical edge into the window channel behind the side mirror bracket. For proper fit, ensure that the only portion of the deflector that is inserted into the window channel (window track) is the thin, opaque, machined edge. **IMPORTANT:** The flared out bottom edge, or end of the deflector must be resting **ON TOP** of the door's outside weatherstrip molding (also known as the "dew wiper").
2. While holding the mirror end of the deflector in place with your left hand, grasp the opposite end with your right hand. Bow the deflector toward you while you insert the rear most portion of the deflector flange into upper right hand corner of the window channel. Leave a gap of approximately $\frac{1}{2}$ " between the top edge of the deflector and the upper corner of the window frame, as this will ease the remainder of the installation.
3. Working from front-to-rear, carefully insert the remainder of the now bowed deflector flange into the window channel by pulling downward on the deflector with your fingertips until the flange of the deflector slips up into the window channel.

IMPORTANT: Prior to closing your windows for the first time ensure that;

- A) The tip or end of the deflector is properly resting on top of the door weatherstrip molding (dew wiper).
 - B) The thin, opaque machined mounting flange is fully and properly inserted into the window channel from front to rear.
4. Carefully and slowly close and open your window at least 5 times to seat the deflector.

NOTE: Some vehicles are equipped with a safety feature that will automatically open the window if any resistance is met. In the event this occurs, simply sandwich the window glass between the palms of your hands as you raise the window to manually assist the window to fully close and stay closed for a few seconds. This should override this feature long enough for the vehicle to become accustomed to the deflector. The Side Window Deflector should be fully seated once the window is left in the closed position for at least 24 hours. Repeat Steps 1-4 for passenger side window installation.

WeatherTech®

No Drill MudFlap



Mounts-In-Minutes™

Perfect
DigitalFit™

Premium Mud Flaps

Engineered
Specifically for
Each Application



No-Drill MudFlap Detail



Reverse Angle
Ford Super Duty shown



QuickTurn™ Detail

- Protect your vehicles most vulnerable rust area with WeatherTech® MudFlaps
- Protects fender and rocker panel from stone chips, slush, dirt and debris
- Installs without tire/wheel removal
- No drilling into vehicles fragile metal surface
- Check for latest applications at weathertech.com

 Proudly Designed,
Engineered and
Manufactured with
American made
tooling in the USA

WeatherTech®

No-Drill MudFlap

*Please see specific
installation instructions
in your package.*

Warning!

The MudFlap is designed to fit vehicles with standard size wheels and tires. Installation of MudFlaps on vehicles with aftermarket wheels or oversize tires may interfere with the MudFlap and will void the warranty and may damage the MudFlap or the vehicle.

General Installation Instructions

1. Start by thoroughly washing your vehicle. Take care to remove all dirt, debris, and stains from each fender in the areas corresponding to where the MudFlaps will be installed.
2. Begin driver's side MudFlap installation by parking the vehicle on level ground with wheels turned fully to the left.
3. Remove the appropriate screws and/or rivets that match up with corresponding holes on the WeatherTech® No-Drill MudFlaps. If your vehicle has plastic rivets, these will have to be removed. In some cases, these rivets will be reused.
4. Identify the driver's side MudFlap by locating the "LH" mark located centrally in the recessed cavity on the tire side of the MudFlap. If your MudFlap has a QuickTurn™ fastener ensure that the QuickTurn™ fastener is in the fully unlocked position using the hex key provided. (QuickTurn™ fasteners have lock and unlock indicators).
5. Position the smooth surfaced portion of the MudFlap so that it fits the contour of the fender. **IMPORTANT**, ensure that the QuickTurn™ fastener remains in the fully unlocked position during this step.
6. Press the MudFlap against the fender for a tight fit. Insert and snug the hex-head screws or bolts if they were removed in Step 3. **IMPORTANT** - Do not fully tighten at this time.
7. First ensure that the QuickTurn™ fastener is positioned properly, then tighten the QuickTurn™ fastener. Verify that the QuickTurn™ fastener is in the fully locked position (indicator will move to locked position) and continue tightening until the fastener has fully clamped onto the fender lip.
8. If your vehicle has plastic rivets, please re-install these.
9. Tighten the hex-head screws or bolts from Step 6.
10. Begin passenger side installation by turning the front wheels fully to the right. Repeat Steps 3-9.

WeatherTech®

License Plate Accessories



ClearCover®

- One piece lens covers entire licence plate
- Multi-Flex™ gasket seals moisture out
- Available in many colors to complement any vehicle
- Click and Stay™ screw caps hide fasteners
- Stainless steel fasteners for secure fit



ClearFrame™

- Multi-Flex™ gasket seats snugly against licence plate preventing vibrations and rattling
- Click and Stay™ screw caps hide fasteners
- Stainless steel fasteners for secure fit



- White
- Brushed Stainless
- Red
- Black
- Chrome
- Gold





PlateFrame™

- Solid one piece frame
- Impact and abrasion resistant
- Click and Stay™ screw caps give sleek design
- Stainless steel fasteners for secure fit



- White
- Brushed Stainless
- Red
- Black
- Chrome
- Gold



- Black
- Chrome



*Proudly Designed,
Engineered and
Manufactured with
American made
Tooling in the USA*

WeatherTech[®]
ClearCover[®], ClearFrame[™] & PlateFrame[™]



General Installation Instructions

1. Remove the Click and Stay™ screw covers from the mounting holes by pushing them out from the rearward side.
2. Lay frame face down on a soft or non-abrasive surface.
3. Position the license plate face down. Make certain that you have a proper fit and seal.
4. Select the four mounting screws that are most appropriate for your vehicle (If your mounting location only uses 2 holes, then see Step 4A FIRST). Carefully position your license plate assembly into place on your vehicle and using a #2 Phillips Head screwdriver, securely fasten with the screws you have chosen, BEING CAREFUL NOT TO OVER-TIGHTEN.
 - A) If the mounting location on your vehicle only uses two screws, then first select machine screws and matching nuts from the hardware pack. Install these two screws through the license plate assembly in the holes that DO NOT go to the mounting holes on the vehicle. Using a #2 Phillips Head screwdriver and a wrench, tighten the two nuts onto the end of each screw, locking the assembly together, BEING CAREFUL NOT TO OVER-TIGHTEN.
5. Finally, position the Click and Stay™ screw covers over each screw with the drain hole on the bottom and push firmly to snap each one into place.

NOTE: Please check state and local laws prior to use

Instructions

Clean with soapy water or window cleaner. Do Not use abrasive pads, harsh detergents or degreasers. Please see specific installation instructions in your package.

WeatherTech®

Sunroof Wind Deflectors



Honda Accord shown



Mazda CX-7 shown

Let The Fresh Air In[®]



- Reduces in-cabin wind noise and air turbulence
- Held securely in place with the MagiClip™ fastening system
- AirCushion™ Gasket protects vehicles finish and seals deflector
- Sleek and sophisticated design for any vehicle with a sunroof



Sunroof Deflector Detail



AirCushion™ Gasket



MagiClip™ Fastener



WeatherTech®

Sunroof Wind Deflectors



General Installation Instructions

1. Place the deflector on the vehicle's roof positioned slightly in front of the sunroof opening, straight and evenly spaced on each of the side of the opening.
2. Assemble the MagiClip™ by sliding the cone nuts onto the flat end of the clips.
3. Insert screw through the washer and holes on the top of the Sunroof Deflector.
4. Hook the clip onto the metal lip of the sunroof opening in a position corresponding to the hole in the deflector. It may be necessary to adjust the deflector's position slightly.
5. Press upward on the MagiClip™ while turning the screw clockwise with some downward pressure.
6. Repeat Steps 2-5 on the other side.
7. Ensure that the deflector is positioned straight and adjust it until properly placed. Tighten both screws until the MagiClip™ is flush with the bottom of the deflector.

Please see vehicle specific installation instructions in your package.

WeatherTech®

Easy-On® Stone & Bug Deflector

- Excellent protection against stone chips and bug stains
- Installs with automotive adhesive tape or fasteners using existing holes . . . no drilling required
- Made from virtually indestructible aerospace-acrylic



Honda Civic shown

Complete Front End Protection



Chevrolet Suburban shown



GMC Yukon shown



Stone & Bug Deflector

Screw Attachment Installations

1. Wash and dry the hood of the vehicle at least 18" from the leading edge of the hood.
2. Attach the Deflector to the underside of hood by screwing the (4) self-tapping screws with rubber washers through the pre-drilled holes in the deflector. A power screw driver is recommended, but once the screw penetrates the inside metal panel, use a regular Phillips screwdriver the remainder of the way. Do not overtighten. Be sure the deflector is properly positioned before using screws to prevent damaging hood.
3. To reduce vibration, adhere the Bump-ons at pre-cleaned locations on the painted hood/fender surface where the deflector may make contact. If the hood will not shut properly, it may be necessary to adjust the hood bumper stops (refer to your owner's manual).

Foam Tape Attachment Installations

1. Wash and dry the hood of the vehicle at least 18" from the leading edge of the hood.
2. Test fit the deflector prior to removal of the foam tape backing to ensure familiarity with installation procedure.
3. Using the alcohol pads provided, clean the first 4" of the hood surface from the leading edge.
4. Position the center line of the WeatherTech® Stone & Bug Deflector with the center line of the hood, peel the backing from the two center mounting flange areas.
5. Align the mounting flange with the leading edge of the hood panel, apply firm pressure and hold for two minutes.
6. Remove backing from the outer two flange areas and repeat Step 5 to complete installation.
7. Please allow to set for one hour before driving vehicle.

Please see specific
installation instructions
in your package.

General Installation Instructions

8. To reduce vibration, adhere the Bump-ons at pre-cleaned locations on the painted hood/fender surface where the deflector may make contact. If the hood will not shut properly, it may be necessary to adjust the hood bumper stops (refer to your owner's manual).

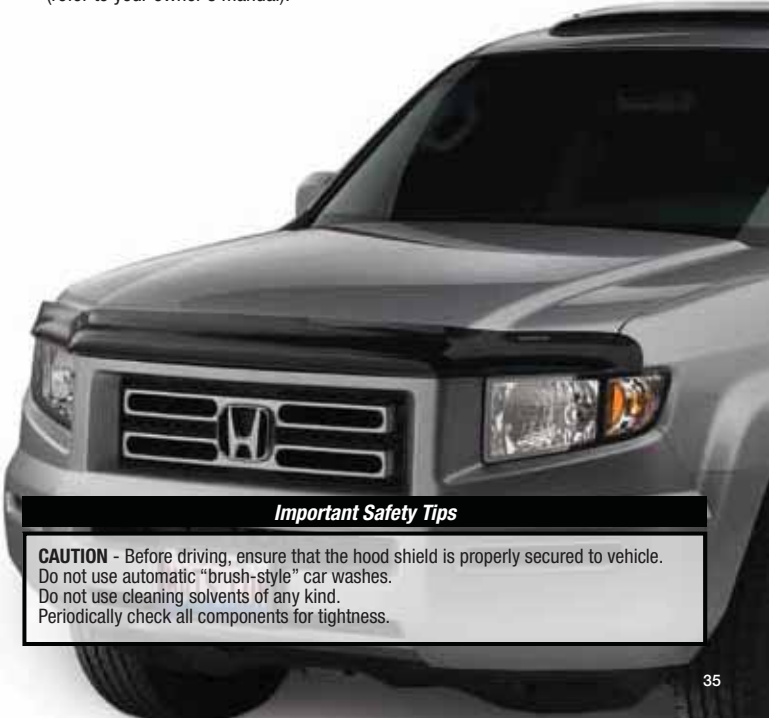

Important Safety Tips

CAUTION - Before driving, ensure that the hood shield is properly secured to vehicle. Do not use automatic "brush-style" car washes. Do not use cleaning solvents of any kind. Periodically check all components for tightness.

WeatherTech[®]AVM[™]

Universal Cargo Mat



- Intelligent design combined with trim lines allow for a truly custom fit
- Tall outer ridges and channels to keep fluids away from vehicle's interior
- Soft flexible rubber compound
- Available in Black, Tan or Gray



*Proudly Designed,
Engineered and
Manufactured with
American made
Tooling in the USA*

General Installation Instructions

1. Open trunk or cargo area of vehicle. Remove loose items and vacuum excess dirt.
2. AVM™ Universal Cargo Mat and place in trunk or cargo area for initial fit.
3. If your vehicle is equipped with removable carpet pad, please use this as a template for trimming your AVM™ Universal Cargo Mat - if desired.
4. If trimming is desired, please use a sharp scissor or shear only removing as little as necessary to obtain proper fit - remember measure twice, cut once.

NOTE: Regular cleaning extends the life of your AVM™ Universal Cargo Mat. The cargo mat should be removed and shaken regularly to remove liquid and loose debris. Clean your AVM™ Universal Cargo Mat using only a mild detergent soap and water. Do not use harsh chemicals or abrasive type cleaners as these products may damage the product. We do not recommend Armor All® or STP Son-of-a-Gun, as these types of products make the AVM™ Universal Cargo Mat slippery.



WeatherTech® TechShade™



- Reflective film chases the sun away in summer
- Reverse to heat absorbing black for winter
- Custom fit for each vehicle
- Unique patented suction cups aid installation and are easy to remove



Suction Cup ensures
TechShade™ placement

 Proudly Designed,
Engineered and
Manufactured with
American made
Tooling in the USA

General Installation Instructions

1. Unroll
2. Install suction cups in desired side
3. Place in windshield



Velcro® Strap for easy stowing



Instructions

Reflective side facing out for reducing interior temperature; Black heat absorbing side facing out for warming your vehicle's interior

WeatherTech®

RackSack®



Expand Your Cargo Capacity

- Expand cargo capacity 13 cubic feet!
- Made of heavy-duty cordura nylon
- Stows away neatly in its own bag
- Measures 29" x 32" x 18"



General Installation Instructions

1. Remove the RackSack® from the carton and spread it out between the front and rear horizontal bars of your luggage rack (if so equipped) with the soft-fleece bottom against the surface of the vehicle. Minor adjustment of the horizontal bars may be necessary (please refer to your vehicle's owners manual).
IMPORTANT: For greater water repellency, and ease of loading, the zippered end of the bag must be toward the rear of the vehicle.
2. Pack your luggage into the RackSack®, loading heavier items first. This will ensure that weight is distributed evenly and low in the carrier.
3. Wrap the longer mounting strap around the underside of the horizontal bar of the luggage rack and attach it to the oversize ITW Nexus™ connectors on top of the bag. If your vehicle is not equipped with front and rear horizontal bars, the attachment straps can pivot to the sides for attachment to the side rails. However, please attach the straps in a manner that will prevent the RackSack® from sliding on the vehicle roof of the vehicle during acceleration or braking.
4. Once all four straps are connected, cinch up the straps evenly to secure the load. Any excess strap material may then be secured by using the "Roll and Wrap™" system. Simply roll the "T" shaped end of the strap toward the connector and fold the Velcro® tabs around the strap to secure it.

IMPORTANT: Please inspect and re-tighten all straps after a few miles of travel as well as periodically during your trip, as your cargo is likely to shift.

NOTE: RackSack® requires roof rack, mounts to the crossbar or side rails



WeatherTech®

Pet Barrier



Pet Barrier

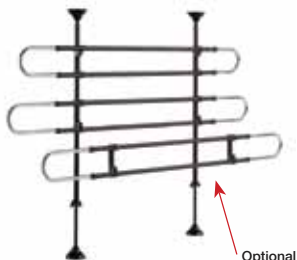

Optional
Extension

Expandable, Extendable Pet Barrier

- Keeps pet safely in rear of vehicle
- Adjustable and expandable to fit any vehicle
- Installs easily without tools or drilling

Tubing Size	1/2", 5/8" & 3/4" Steel
Total Weight	7.3 lbs.
Max Height	42" (without extension) 51" (with extension)
Max Width	66"

General Installation Instructions

1. Insert the Vertical Upright Tubes (C) through the Plastic Vertical Brackets (B).
2. Locate the end of the Threaded Rod Assembly (E) with the wing nut. Press a Support Foot (G) onto this end. Repeat with the other Threaded Rod Assembly.
3. Insert the Threaded Rod/Support Foot Assemblies into the Vertical Upright Tubes. Make sure the Wing Nuts (D) center into the Vertical Upright Tubes.
4. Install the remaining 2 Support Feet (G) onto the tops of the Vertical Upright Tubes (C).
5. Center the assembled Pet Barrier in your vehicle with the Threaded Rod Assembly portion on the floor and extend it vertically until it is expanded snugly against the roof and floor of the vehicle. Be sure the Vertical Tubes are perpendicular to the floor. To secure the position, turn the wing nuts until they are snug against the Vertical Upright Tubes.
6. Once the barrier is firmly installed, you can optimize the function of your Pet Barrier by adjusting the Telescoping Hoop Assemblies (A). First adjust the Telescoping Hoop Assemblies by pushing or pulling them horizontally. Then you can adjust to fit vertically.
7. When the Pet Barrier is adjusted to your satisfaction, lock your adjustments in place by installing the 4 screws (H).

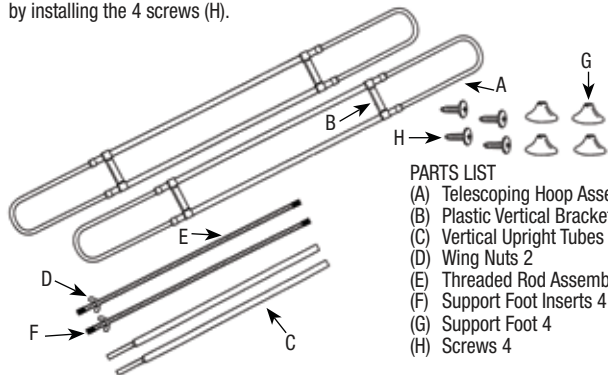

PARTS LIST

- (A) Telescoping Hoop Assembly 2
- (B) Plastic Vertical Brackets 4
- (C) Vertical Upright Tubes 2
- (D) Wing Nuts 2
- (E) Threaded Rod Assembly 2
- (F) Support Foot Inserts 4
- (G) Support Foot 4
- (H) Screws 4

WeatherTech®

LampGard™



Simple Headlamp Protection

- Protect lights from cracking, scratching and pitting
- Sticks directly to the lamp surface
- Designed to specifically fit each vehicles fog lights and turn indicators

SAFETY TIPS

1. Remove any other floor mats prior to installation.
2. Before driving make sure that the mats do not in any way interfere with the safe operation of this vehicle.
3. Before driving make sure that the mats do not in any way interfere with the accelerator pedal, brake pedal or clutch pedal.
4. Make sure that all drivers of this vehicle are aware of these safety tips.
5. If so equipped, please be sure to use any retention devices supplied with your vehicle or mats.

WE GUARANTEE YOUR SATISFACTION

If you are not happy with your order, return your unused product within 30 days for a complete refund, less shipping & packaging.

WARRANTY

WeatherTech® products are guaranteed against faulty materials and workmanship for a period of three years from the date of purchase. Exclusions to this warranty are wear through due to severe abrasive conditions, chemical contamination, such as spilled gasoline, bleach, etc. We are reasonable people and we believe in customer satisfaction. Depending on the situation, we will either replace your product at no charge or charge you a prorated amount for a replacement. Some products have an extended guarantee period. See specific guarantee information for each product at WeatherTech.com Thank you for your business.

ADDITIONAL ORDERING INSTRUCTIONS

Now that you see how well WeatherTech® Products protect your vehicle, you'll want to order additional items for your other cars as well. So just tell us the

year, make and model of your vehicle, and we'll ship you the items that will let you keep protecting your vehicle for years to come.

SHIPPING

When multiple items are ordered from a single product group advertising a shipping special, the customer pays the initial delivery fee on the first item and we pay regular ground shipping on additional items purchased from the same product group shipping to the same address within the 48 contiguous states. Merchandise ordered from different product groups may be subject to additional delivery charges. Express delivery available.

Prices subject to change without notice. Check held for 10 business days. Illinois residents add 8% sales tax.



WeatherTech®

pg. 32

pg. 28

pg. 8

pg. 4

pg. 44

pg. 24

pg. 4

pg. 8

pg. 24

pg. 24

pg. 16

pg. 12

pg. 20



Learn more about floor mats on our website.